

United States Patent

Yamada et al.

[15] 3,706,276

[45] Dec. 19, 1972

[54] **THERMAL TRANSFER SHEET**
 [72] Inventors: **Yoshikazu Yamada**, Sierra Madre;
Joseph Tat-Hin Sund, Los Angeles;
Daniel R. Logue, San Gabriel, all of
 Calif.

[73] Assignee: **Bell & Howell Company**

[22] Filed: **Sept. 18, 1970**

[21] Appl. No.: **73,522**

[52] U.S. Cl.**101/453**, 101/471, 117/36.4,
 156/153, 161/406, 250/65 T

[51] Int. Cl.**B41m 5/18**

[58] Field of Search.....101/468, 470, 471, 473, 453;
 250/65 T; 117/36.4; 156/153; 161/406

[56] **References Cited**

UNITED STATES PATENTS

358,774	3/1887	Bonnaud	101/467
1,514,677	11/1924	Seyfferth	101/426 X
2,362,980	11/1944	Ball	101/426 X

3,458,336	7/1969	Newman	117/36.4
3,185,087	5/1965	Newman et al.....	101/471
3,347,696	10/1967	Newman.....	101/470 X
3,280,735	10/1966	Clark et al.....	101/470

FOREIGN PATENTS OR APPLICATIONS

25,256	1912	Great Britain.....	101/426
--------	------	--------------------	---------

Primary Examiner—Clyde I. Coughenour
Attorney—Nilsson, Robbins, Wills & Berliner

[57] **ABSTRACT**

A sheet for receiving a thermally formed design of material from a transfer sheet or the like of thermally transferable heat-sensitive material. The surface of the receiving sheet is defined by material which has been formed under conditions yielding a reticulated, stippled or particulated texture thereby providing a plurality of spaced contacts for receiving the transferred material with a resolution of at least 5.0 line pairs per millimeter.

7 Claims, 11 Drawing Figures

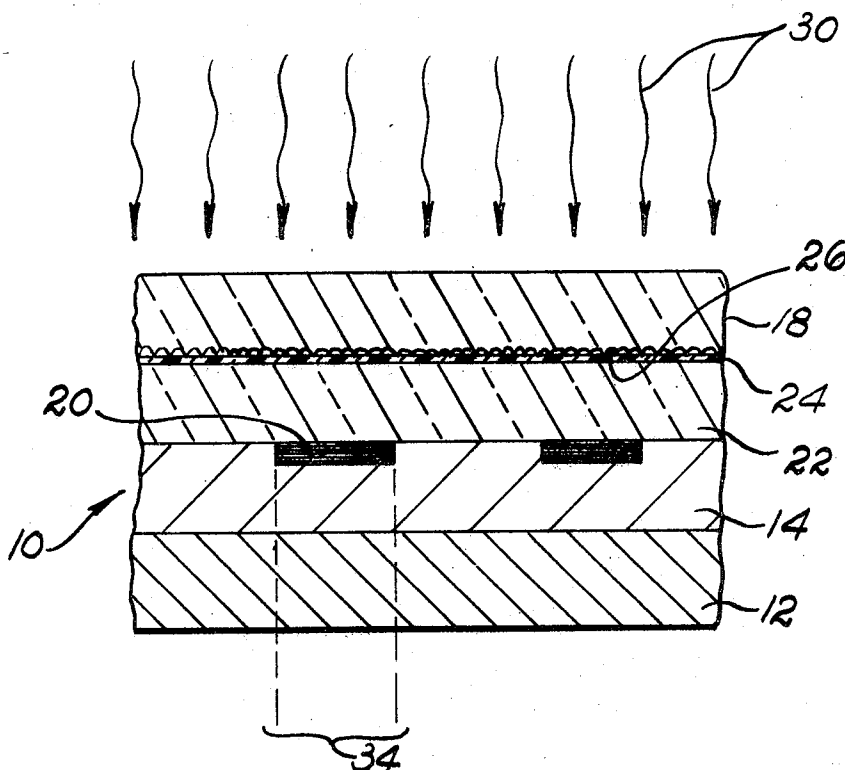

Fig. 1.

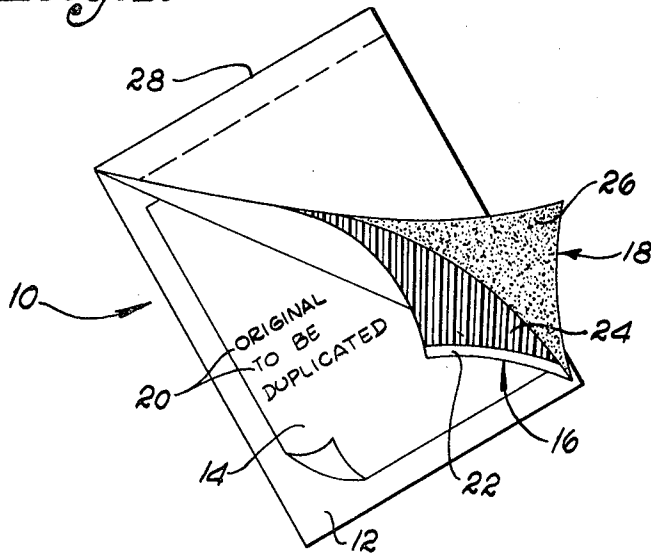

Fig. 2.

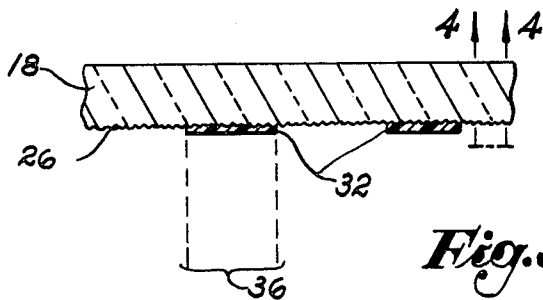
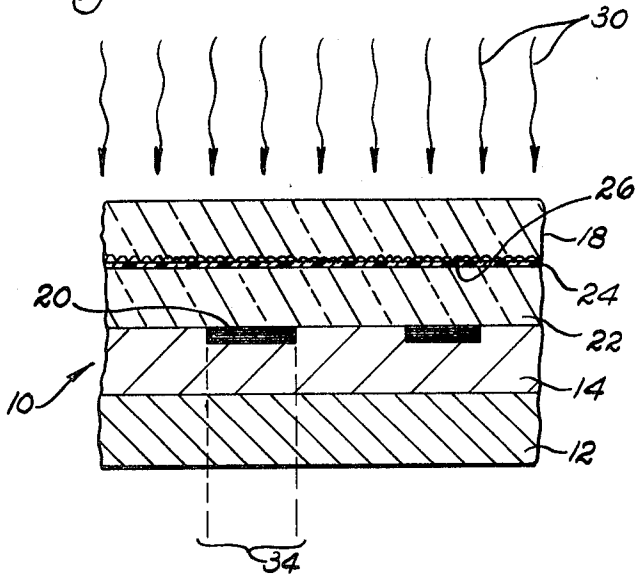

Fig. 3.

Fig. 4.

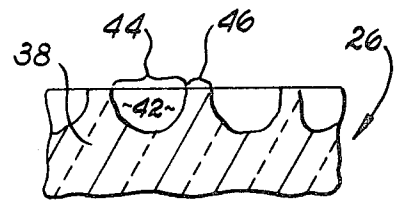
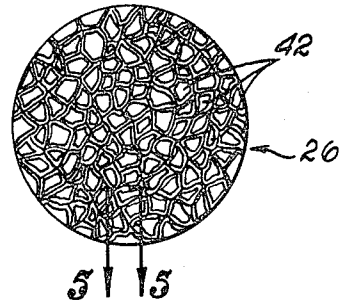

Fig. 5.

INVENTORS
 YOSHIKAZU YAMADA
 JOSEPH TAT-HIN SUND
 DANIEL R. LOGUE
 By Nilsson, Robbins, Wills & Berliners.
 Attorneys.

Fig. 6.

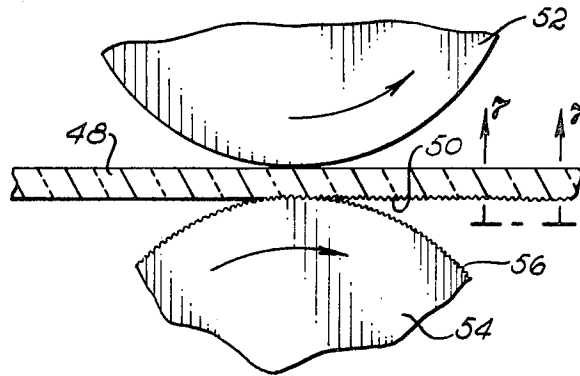

Fig. 7.

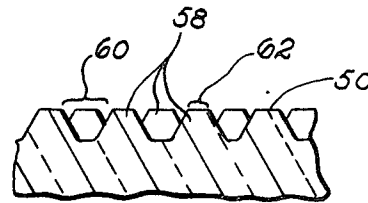
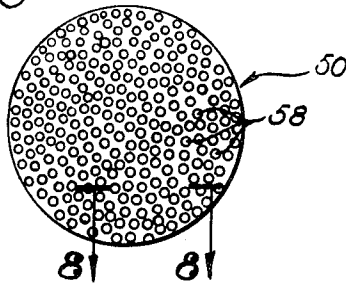

Fig. 8.

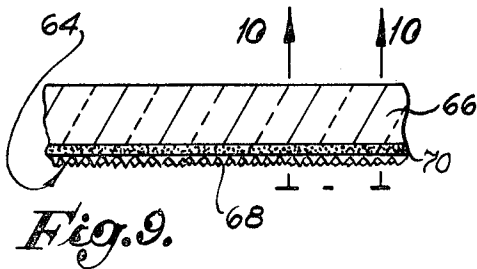

Fig. 9.

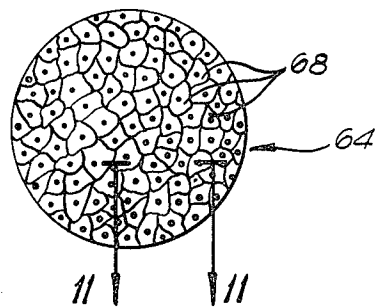

Fig. 10.

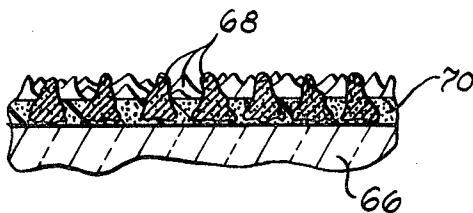

Fig. 11.

INVENTORS
YOSHIKAZU YAMADA
JOSEPH TAI-HIN SUND
DANIEL R. LOGUE
By *Nilsson, Robbins, Wells & Berliner*
Attorneys.

THERMAL TRANSFER SHEET

FIELD OF THE INVENTION

The field of art to which the invention pertains, includes the field of planographic printing processes, particularly those utilizing soluble dye transfer.

BACKGROUND AND SUMMARY OF THE INVENTION

Duplicating processes involving the thermal transfer of heat-sensitive material are well known in the prior art. For a detailed discussion of various duplicating processes utilizing thermal transfer, reference may be made to U.S. Pat. Nos. 3,122,997 and 3,122,998 issued to Raczynski et al. As further background hereto, reference may also be made to U.S. Pat. Nos. 2,808,777, 2,939,009, 3,260,603, 3,262,386, 3,283,708 and 3,304,015. Typically, an original to be duplicated is placed in an assembly with a transfer sheet substrate carrying a fusible layer of heat sensitive material and an image-receiving sheet which has its receiving surface in contact with the layer of fusible material. The position and facing of the original document sheet relative to the transfer and receiving sheets can be varied depending upon whether a right-reading or a laterally reverse reading image is desired on the image receiving sheet. The image on the original document must be defined by an infrared absorptive material such as carbon, heavy metal, or certain organic compounds so that the image areas of the original document, upon exposure, will absorb more infrared radiation than the surrounding, non-image areas. The absorbed infrared radiation is converted to thermal energy forming a thermal pattern in the original document which corresponds to the visible image pattern. This heat pattern is conducted through the substrate of the transfer sheet to the heat sensitive layer. The heat sensitive layer is selectively fused in correspondence to the image and the fused material is transferred to the image-receiving sheet.

Following image transfer, depending upon the manner of placement of the original document, the image-receiving sheet may serve as a facsimile copy of the original document or it may be utilized as a master in a solvent duplicating or lithographic printing process. The heat-sensitive layer of the transfer sheet should contain, in addition to the fusible material, the necessary components for the ultimate application of the transferred image. For example, in spirit duplication processes, the heat-sensitive layer contains wax, or other fusible substance, mixed with an alcohol soluble dye to produce the image color in the ultimate copy. The waxy material is thermally transferred in reverse reading fashion to the image-receiving sheet, normally referred to as a master. The mater is placed on the drum of a duplicating machine and contacted with a succession of sheets of copy paper previously wet with a volatile alcohol solvent for the dye. The solvent dissolves part of the dye in the master image and transfers it to the copy paper. In another type of solvent duplicating process, the transferred image material contains a chemical reagent which reacts with a second reagent on the copy paper to yield a color. The second reagent may be originally in the copy paper or it may be delivered to the paper in duplicator fluid applied prior to contact with the master sheet. In offset lithographic

printing, the material transferred to the image-receiving sheet, normally referred to as a printing plate, defines a right-reading image. If a reverse-reading image is initially prepared on an image-receiving sheet, it can be transferred to a direct image lithographic plate by contacting the thermally produced image with the face of the lithoplate and heating, as known to the art.

While thermal image transfer processes are relatively inexpensive, and effective in terms of color density for short-run duplication, they are generally characterized by greatly decreased image resolution and sharpness. We have found that with commercial spirit duplication transfer sheets, the resolution of the thermal image pattern reaching the heat-sensitive layer is better than 10 line pairs per millimeter, but resolution of the transferred image is only three to 4.5 line pairs per millimeter or lower. Accordingly, greatly decreased image resolution results from the steps involving fusion and transfer of the heat sensitive material to the image-receiving layer. Such low resolution is carried over into the final copy.

The present invention provides an image-receiving sheet which dramatically increases the level of resolution and acuity or sharpness achieved in the transference of image material from the heat-sensitive layer of transfer sheet. Specifically we have found that if the surface of the image-receiving sheet is textured so that there are a large number of contact points between the heat-sensitive layer of the transfer sheet and the receiving sheet surface, then the transfer of fused material to the image-receiving layer is limited to flow through these points or regions, and the resultant resolution on the receiving layer is greatly improved. A thermally formed design of fused material can be transferred having improved acuity and having a resolution of at least 5.0 line pairs per millimeter and typically with a resolution of seven to 12 line pairs per millimeter or finer.

In accordance with the present invention, the surface of the image-receiving sheet is defined by material which is formed under conditions yielding a reticulated, stippled and/or particulate texture. In one form of the invention, organic polymeric material, such as polyvinyl chloride, is formed under ambient conditions of high relative humidity, e.g., 50-75 percent, to yield a surface having a reticulated, or wrinkled or cracked texture. Further improved results are obtained by incorporating with the polymeric material a substantial amount of particulate material, such as kaolin which aids in the formation of the reticulated structure and improves mass transfer characteristics.

In another embodiment, the surface of the image-receiving sheet is defined by material which has been embossed to yield a stippled or relieved texture. The embossed pattern is chosen so as to provide a large number of contact points and can be formed in the surface of the image-receiving layer by relieving the surface with a patterned roller, by casting the film on a textured surface, or by any expedient method. The transfer characteristics of the image-receiving sheet can be enhanced by dispersing inorganic particulate material throughout the surface defining material.

In still another embodiment, the image-receiving sheet includes a base, particulate material and a binder securing the particulate material to the base so as to

define the image-receiving surface as a particulate or granulated surface.

BRIEF DESCRIPTION OF THE DRAWINGS

FIG. 1 is a perspective view of a master sheet-transfer sheet-original document assembly in accordance with the present invention;

FIG. 2 is a schematic representation in cross-section of the assembly of FIG. 1 during infrared exposure;

FIG. 3 is a schematic representation in cross-section of the master sheet subsequent to image transfer;

FIG. 4 is a schematic detailed view on line 4—4 of FIG. 3, in the direction of the arrows;

FIG. 5 is a cross-sectional view taken on line 5—5 of FIG. 4, in the direction of the arrows;

FIG. 6 is a schematic representation of an embossing process to produce a master sheet with a stippled image-receiving surface;

FIG. 7 is a schematic detailed view on line 7—7 of FIG. 6, in the direction of the arrows;

FIG. 8 is a cross-sectional view on line 8—8 of FIG. 7, in the direction of the arrows;

FIG. 9 is a schematic representation in cross-section of a master sheet having a particulate image-receiving surface;

FIG. 10 is a schematic detailed view on line 10—10 of FIG. 9, in the direction of the arrows; and

FIG. 11 is a cross-sectional view on line 11—11 of FIG. 10, in the direction of the arrows.

DETAILED DESCRIPTION

As required, detailed illustrative embodiments of the invention are disclosed herein. However, it is to be understood that these embodiments merely exemplify the invention which may take many forms radically different from the specific illustrative embodiments disclosed. Therefore, special structural and functional details are not to be interpreted as limiting, but merely as a basis for the claims which define the scope of the invention. Somewhat in this regard, the illustrative embodiments herein comprise master sheets which are used in the transfer step of a spirit duplicating process. However, as hereinbefore indicated, the concepts and embodiments of this invention can be utilized in other solvent type duplicating process, such as the type involving a chemical reaction, or with lithographic printing processes and the like.

Referring to FIG. 1, a "sandwich" assembly 10 is illustrated which includes a base sheet 12 of relatively thick paper and which supports an original document 14 to be duplicated, a transfer sheet 16 and an image-receiving, master sheet 18. The original document 14 contains infrared-absorptive indicia or images 20 on its face and is placed face-up on the base sheet 12, beneath the relatively thin transfer sheet 16. The transfer sheet 16 includes a plastic substrate 22 which carries a thin layer of heat-sensitive material 24 on the side opposite the original document 14. The master sheet 18 is disposed with its image-receiving surface 26 adjacent the transfer sheet layer 24 of heat-sensitive material. The top edges of the transfer sheet 16 and master sheet 18 are secured by adhesive or the like to the top edge 28 of the base sheet 12.

Referring additionally to FIG. 2, there is shown a more detailed view of the disposition of the com-

ponents of the assembly illustrated in FIG. 1. As indicated, the original document 14 is placed on the supporting base sheet 12 with its infrared-absorptive indicia 20 facing upwardly. Such indicia is constituted of carbon, heavy metal, or any material which upon exposure will absorb more infrared radiation than the surrounding non-image areas, so as to convert the absorbed infrared energy to a thermal pattern corresponding to the visible image pattern on the document 14. The transfer sheet substrate 22 can be formed of Mylar (a transparent, tensilized polyethylene glycol terephthalate polyester film) which is sufficiently thin, about 0.5 mil, to avoid significant attenuation of the conducted heat pattern. Utilizing a 1,000 watt tungsten lamp as the infrared source, the substrate 22 allows a thermal image pattern to reach the heat sensitive layer 24 with better than 10 line pairs per millimeter resolution.

The heat-sensitive layer 24 can be any of the generally available commercial materials, such as described in the Raczynski et al. patents referred to above. In the present embodiment, the layer 24 is constituted of a mixture of wax and alcohol soluble dye, such as crystal violet, or the like, as typically employed in a spirit duplicating process. The dye-wax combination, normally referred to as "carbon," is coated to a thickness of about 0.4 - 0.5 mils on the plastic substrate 22. The combination is substantially transparent to infrared rays.

The master sheet 18 is disposed with its image-receiving surface 26 in direct contact with the transfer sheet "carbon" 24. As schematically illustrated, the image-receiving surface 26 is textured with a plurality of spaced contacts which will hereinafter be described in more detail and which serve to focus the transfer of fused material from the heat-sensitive layer 24. By providing a large number of contact points between the heat-sensitive layer 24 and the receiving sheet surface 26, the transfer of fused material is limited to the flow through these points or areas, and the resultant resolution and acuity of image on the receiving sheet 18 is dramatically improved.

The master sheet 18 is formed of material which is transparent to infrared radiation and can be conveniently formed of Mylar, polypropylene, polyethylene, or the like. Since the master sheet 18 must be sufficiently strong to withstand a large number of impacts during subsequent duplication, it is made relatively thick, about 1-2 mils.

The assembly of base sheet 12, document 14, transfer sheet 16 and master sheet 18 is sandwiched together under pressure so that directly opposing surfaces are contiguous with one another. The assembly 10 is exposed to radiations 30 rich in infrared, directed onto the master sheet 18 so as to penetrate the master sheet 18 and transfer sheet 16 and impinge onto the original document 14. The radiation 30 generates a temperature rise in the image portions 20 of the document 14, resulting in a thermal pattern emanating from the document 14.

Referring additionally to FIG. 3, as a result of the generation of a thermal pattern, the heat-sensitive transfer material 24 is selectively fused to a softened condition in regions 32 corresponding to the indicia 20. The fused, softened transfer material 32 is then trans-

ferred to the textured master sheet surface 26 to produce an image which corresponds to the image defined by the indicia 20 on the original document 14. As is well known, the exposure time required is a function of the materials involved and the intensity of radiation. After the infrared radiation exposure has been terminated, the imaged master sheet 18 may be moved from the assembly 10 and will carry the fused regions of the transfer layer 24 away from the transfer sheet 16. As indicated at 34 and 36, the lateral extent of the transfer material 32 is substantially coterminous with the lateral extent of the corresponding portions of the document indicia 20. The result is very high resolution previously unobtainable with thermal transfer procedures. In the assembly shown, the material 32 is transferred in mirror image fashion and thus the master sheet 18 would be used to produce right-reading copies.

As above indicated a variety of techniques can be used to obtain a textured surface which can receive a thermally formed design of transfer material with a resolution of at least 5.0 line pairs per millimeter. Referring now to FIGS. 4 and 5, a surface structure produced by one particular method is illustrated. In this embodiment, the master sheet surface 26 is defined by organic polymeric material 38 which is formed under conditions yielding a reticulated or crackled texture. To achieve this structure, a thin uniform layer of polymer solution is spread over a smooth substrate, e.g., of plastic, and the drying controlled so that instead of a smooth film layer, a reticulated surface is produced. The extent of reticulation can be controlled by choice of polymer, solvent, diluent and drying conditions.

Generally, as polymer, one can use any organic polymeric material which is commonly used to form thin films, such as polyvinyl chloride, ethyl cellulose, polystyrene, chlorinated rubber, polymethylmethacrylate, cellulose acetate, polyvinylidene polymers, cellulose nitrate, condensation resins of melamine-formaldehyde, urea-formaldehyde, and diallyl orthophthalate-phenol, and the like. In addition to forming a thin film, the polymeric material should be capable of accepting the wax or other material which may be carried by the transfer sheet as a heat-sensitive fusible material. Additionally, the polymeric material should be relatively non-distortable at thermographic temperatures. The choice of material can best be made on the basis of well known properties, and where not known, can be readily determined. For further description of polymers which may be utilized herein, reference can be made to Modern Plastics Encyclopedia, McGraw-Hill, Inc., (1968) herein incorporated by reference.

Optionally, a plasticizer may be utilized in conjunction with the polymeric material, plasticizing amounts generally ranging between 25 and 100 percent by weight of the polymer. Suitable plasticizers include tricresyl phosphate, tri(2-ethylhexyl)phosphate, dioctylphthalate, di(2-ethylhexyl)tetrahydrophthalate, di(2-ethylhexyl)maleate, polyethylene glycol, and the like.

As carrier, one can utilize any appropriate solubilizing material with or without diluent which is sufficiently volatile to form a solid film in reasonable time. Suitable materials include xylene, dimethylformamide,

acetone, toluene, methyl alcohol, tetrahydrofuran, ethyl alcohol, ethyl acetate, methylene dichloride, ethyl ether, methyl isobutyl ketone, butyl carbitol, butyl cellosolve acetate, dimethyl sulfoxide, and the like, or mixtures thereof.

Importantly, the coating is formed under conditions which ordinarily would be avoided in the preparation of a smooth plastic film. In accordance with one embodiment, the coating is formed under relatively high humidity conditions, in particular under ambient conditions of 50 - 75 percent relative humidity. Under these conditions, continued rapid curing and escape of solvent sets up shrinkage stresses and strains that cause the film to wrinkle. Regardless of the reasons for the occurrence, films which are produced under the aforementioned conditions have a texture such as is illustrated in FIGS. 4 and 5 wherein the dry film has a cellular structure in which ridges 40 form open (looking from the top) cells 42. In accordance herewith, the structure is sufficiently reticulated so that the spacing between the ridges 40, as indicated at 44, is about 5 - 45 microns and the widths of the ridges 40, as indicated at 46, are about 4 - 8 microns. The result is a film with sufficient inherent resolution characteristics to receive the transferred wax or like material with a resolution of at least 5.0 line pairs per millimeter.

In accordance with a further embodiment herein, inorganic particulate material can be added to the organic polymeric material prior to formation of the coating. The particulate material is chosen simply on the basis of providing a textured coating, rather than for any absorption or adsorption characteristics. Suitable particulate materials are the clays, notably the silicate pigments, such as kaolin and components thereof such as kaolinite. Other materials include alumina, titania, silica, magnesia, and the like. In general, a particle size distribution between about 0.1 to about 25 microns is preferred. For example, Kaolinite UF, produced by the Georgia Kaolin Co., has a particle size distribution from about 1 micron down to less than 0.1 micron with an average particle size of about 0.2 micron.

Coating under high humidity conditions is only one method of obtaining the required reticulation which can also be obtained by proper choice of solvent and drying temperature with respect to a particular polymeric material. With some combinations, reticulation can be obtained repeatedly without high humidity, while in other cases no practical control is possible without highly humid ambient conditions. Furthermore, with many polymers, such as polyvinyl chloride, a reticulated structure suitable for use herein can be obtained if the otherwise smooth polymer is contacted soon after coating with a non-solvent liquid such as water. For further methods of forming a textured coating, see "ORGANIC COATINGS" by A.G. Roberts, Building Science Series 7, February 1968, published by the U.S. Department of Commerce (National Bureau of Standards) incorporated herein by reference.

Referring now to FIG. 6, there is schematically illustrated an alternative method of providing an image receiving sheet 48 with a textured surface 50. In this embodiment, the surface 50 is stippled or relieved by an embossing step wherein the receiving sheet 48 is passed between rollers 52 and 54, one of the rollers 54, having a surface 56 textured in accordance with the pattern desired to be applied to the receiving sheet 48.

Any of the aforementioned organic polymer materials can be used which may include inorganic particulate material dispersed therein, as described above.

Referring to FIGS. 7 and 8, a surface 50 is formed having a plurality of stipples 58 which are defined by depressions into the surface 50 as a result of the embossing step. The distance between stipples, as indicated at 60, is about 5 - 30 microns and the widths of the individual stipples, as indicated at 62 is in the range of about 5 - 20 microns. Alternatively, the surface 56 of the embossing roller 54 can be structured so as to yield any desired texture design, including the provision of a network similar to the reticulated structure of FIGS. 4 and 5. Furthermore, other methods of embossing can be utilized, such as casting the image receiving sheet in a mold having a suitable texture design.

Alternatively, a mold can be made from a reticulated pattern as illustrated in FIGS. 4 and 5, and a polymeric film cast from this mold to yield a master having a reticulated surface texture.

Referring now to FIGS. 9-11, there is illustrated another alternative embodiment in which the image-receiving surface 64 of an image-receiving sheet 66 is constituted by the surface contour of a layer of fine particles 68 to provide a particulate or granulated texture. In this embodiment, the image receiving side of the sheet 66 is coated with an adhesive 70 and finely ground inorganic particulate material is applied to the adhesive 70 to form a uniform layer of particles 68 to define the particulate image-receiving surface 64. As shown in FIG. 11, the particulate material 68 extends above the adhesive binder 70. Any of the previously described inorganic particulate material can be utilized.

The following examples will further illustrate various aspects of the invention.

EXAMPLE I

Thirty grams of polyvinyl chloride was dissolved in 200 milliliters of a solvent blend of a xylene dimethylformamide (2:1 parts by volume). The solution was ball-milled for 15 hours and then applied to a 1 mil sheet of Mylar. A Bird coating bar was used to apply the solution so as to obtain a dry coating thickness of 0.5 mil. The coating was dried under 50-75 percent relative humidity conditions with the result that the dried surface was reticulated and had the appearance generally indicated in FIG. 4.

The coated sheet was placed with its reticulated surface in contact with the dye-wax mixture of a transfer sheet sold by Bell & Howell Company under the trademark "Ditto Fax Master," type C4 having a "carbon" layer 0.4 - 0.5 mil thick on a 0.5 mil thick Mylar substrate. In order to measure resolution, a National Bureau of Standards Microcopy Resolution Test Chart (1963A) was used as the "original" to be duplicated and placed beneath the transfer sheet, supported on a base sheet, such as the base sheet 12 of FIG. 1. Thermal exposure was made utilizing a spirit process exposure and printing unit sold by Bell & Howell Company under the trademark "Ditto Combomatic." Exposure settings on this machine run from a high exposure of 1 to a low exposure of 10. Exposure was made at a setting of 7.5 to obtain a master sheet having a resolution of 10 line pairs per millimeter.

In comparison, resolution values were obtained on commercially available image-receiving sheets. Utilizing the same exposure and transfer sheet as above, images were transferred to white tissue sheets and clear Mylar sheets. The transferred images had resolutions ranging from 3 to 4.5 line pairs per millimeter.

EXAMPLE II

Five grams of an 80 weight percent normal butyl acetate solution of an arylsulfonamideformaldehyde resin, sold by Monsanto under the trademark "Santolite MS" were dissolved in 100 ml of a solvent blend of xylene and dimethylformamide (2:1 parts by volume) to provide a solution of plasticizer. Fifteen gram of polyvinyl chloride were added to the solution and stirred until dissolved. The solution was coated on a 1 mil Mylar sheet and dried at room temperature, the drying resulting in an 0.5 mil dry coating having a reticulated surface. The thus prepared sheet was assembled in the manner of Example I with a transfer sheet and resolution chart and exposed in the "Ditto Combomatic" exposure unit at a setting of 7.5. The dye-wax combination was transferred from the transfer sheet with an image resolution of nine line pairs per millimeter.

EXAMPLE III

Thirty grams of polyvinyl chloride and 60 grams of kaolin were added to 200 ml of a solvent blend of xylene and dimethylformamide (2:1 parts by volume) and the formulation was mixed in a Waring blender. The blended formulation was applied to one side of a 1.5 mil Mylar sheet and dried at room temperature to provide an image-receiving surface 0.4 mil thick. A reticulated surface structure was obtained having ridge to ridge distances of about 16-32 microns. Exposure and thermal transfer were accomplished in the manner described in Example I, the transferred image having a resolution of eight line pairs per millimeter.

EXAMPLE IV

One hundred-twenty grams of Kaolinite UF and 10 ml of Triton GR7 (anionic surfactant obtained from Rohm & Haas Company) were ball-milled in 300 ml of xylene for 24 hours. The Kaolinite dispersion was blended with a solution of 60 grams of low molecular weight polyvinyl chloride in 300 ml of a solvent blend of xylene and dimethylformamide (1:2 parts by volume) utilizing a Waring blender. The blended formulation was coated on a 1.5 mil polyester substrate and dried at about 72°-75° F under relative humidity of between 50 and 75 percent to yield an image receiving sheet having a coating weight of 0.8 grams per square foot and a finely reticulated surface. Exposure and thermal transfer were accomplished in the manner of Example I to obtain a transferred image having a resolution of 12.5 line pairs per millimeter.

EXAMPLE V

A coating formulation was prepared as in Example IV and coated on a 1.5 mil polyethylene substrate to a dried coating thickness of 0.2 mil. The drying temperature and humidity conditions were the same as in Example IV yielding a finely reticulated structure. Upon

exposure and thermal transfer in the manner described in Example I, the transferred image had a resolution of eight line pairs per millimeter.

EXAMPLE VI

A sheet of 1 mil thick Lexan polycarbonate was sprayed on one side with Krylon liquid spray adhesive No. 8010 to define an image-receiving side. Finely ground magnesium oxide of USP grade was applied to the adhesive coated surface prior to its drying to form a uniform layer of particles. The adhesive was allowed to dry and the excess particulate material was brushed off. Exposure and thermal transfer were accomplished in the manner described in Example I to obtain a transferred image having a resolution of 10 line pairs per millimeter.

EXAMPLE VII

A sheet of 1 mil thick Mylar was coated with rubber cement on one side and finely ground alumina powder was dusted over the tacky coated surface. After drying, and brushing off of excess particulate material, exposure and thermal transfer were accomplished in the manner described in Example I to obtain a transferred image having a resolution of nine line pairs per millimeter.

EXAMPLE VIII

To prevent powder losses, an alumina coated sheet was prepared as in Example VII and was then sprayed with a solution of polyvinyl pyrrolidone. Exposure and thermal transfer was conducted in the manner described in Example I to produce a thermally transferred image having a resolution of 7.1 line pairs per millimeter. There was no alumina dust on the carbon transfer sheet from which the transfer was made.

The foregoing illustrations of a thermal image transfer process should be considered merely exemplary. Many different types of assemblages and locations of radiation sources can be used as well known to the art and as set forth in the above-referred to Raczyinski,

et al. patents.

We claim:

1. In combination, a donor sheet carrying a thermally transferable heat-sensitive material, a donee sheet, for receiving said heat sensitive material, having a surface textured with a continuous plurality of ridges defining discrete depressed regions, opposed portions of said ridges being spaced a distance of 5-45 microns whereby to provide spaced contacts receptive to said heat-sensitive material for receiving, upon contact with said layer, thermal transfer from said layer and separation of said sheets, a thermally formed design of said material having a resolution of at least 5.0 line pairs per millimeter.

2. The invention according to claim 1 in which the surface of said sheet is reticulated.

3. The invention according to claim 2 in which said surface-defining material includes a substantial amount by weight dispersed therein of inorganic particulate material.

4. The invention according to claim 2 in which said surface-defining material comprises polyvinyl chloride as the major organic component thereof.

5. The invention according to claim 2 including from about 0.5 to about 8 parts by weight of kaolin per part of said surface-defining material dispersed in said surface-defining material.

6. The invention according to claim 1 in which the surface of said sheet is defined by organic polymeric material having a reticulated texture.

7. In combination, a donor sheet carrying a layer of thermally transferable heat-sensitive material, a donee sheet for receiving said heat-sensitive material, said sheet comprising a base, particulate material and a binder securing said particulate material to said base, said particulate material extending above said binder to define a textured surface in contact with said heat-sensitive material for receiving, upon contact with said layer, thermal transfer from said layer and separation of said sheets, a thermally formed design of said heat-sensitive material having a resolution of at least 5.0 line pairs per millimeter.

* * * * *

45

50

55

60

65