

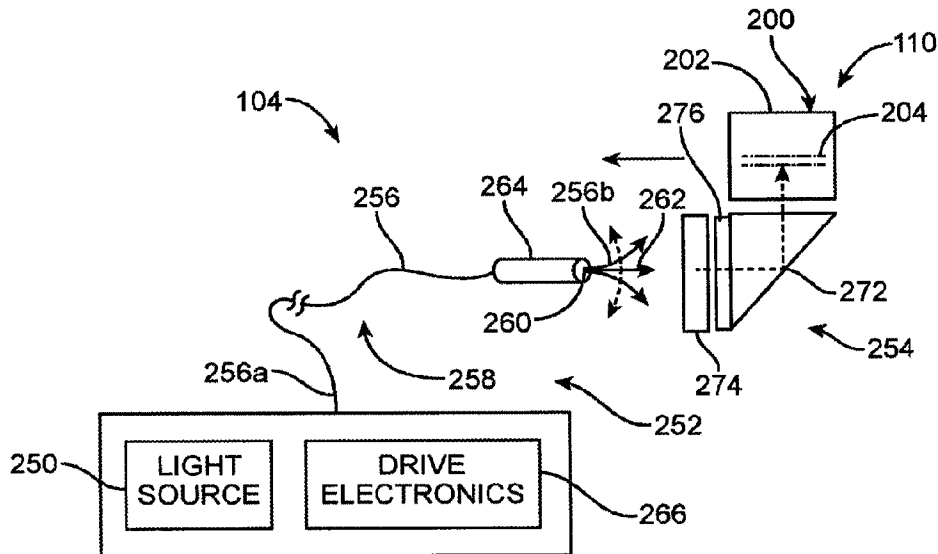

(86) **Date de dépôt PCT/PCT Filing Date:** 2016/10/06
 (87) **Date publication PCT/PCT Publication Date:** 2017/04/13
 (45) **Date de délivrance/Issue Date:** 2022/12/06
 (85) **Entrée phase nationale/National Entry:** 2018/03/07
 (86) **N° demande PCT/PCT Application No.:** US 2016/055823
 (87) **N° publication PCT/PCT Publication No.:** 2017/062667
 (30) **Priorité/Priority:** 2015/10/06 (US62/238,052)

(51) **Cl.Int./Int.Cl. G02B 5/18** (2006.01),
G02B 6/10 (2006.01)
 (72) **Inventeurs/Inventors:**
 YEOH, IVAN L., US;
 CHENG, HUI-CHUAN, US;
 EDWIN, LIONEL ERNEST, US;
 TINCH, DAVID, US;
 WELCH, WILLIAM HUDSON, US
 (73) **Propriétaire/Owner:**
 MAGIC LEAP, INC., US
 (74) **Agent:** RICHES, MCKENZIE & HERBERT LLP

(54) **Titre : SYSTEME DE REALITE AUGMENTEE/VIRTUELLE AYANT UN RESEAU DE DIFFRACTION A ANGLE INVERSE**
 (54) **Title: VIRTUAL/AUGMENTED REALITY SYSTEM HAVING REVERSE ANGLE DIFFRACTION GRATING**



(57) **Abrégé/Abstract:**

A display subsystem for a virtual image generation system comprises a planar waveguide apparatus, an optical fiber, at least one light source configured for emitting light from a distal end of the optical fiber, and a mechanical drive assembly to which the optical fiber is mounted as a fixed-free flexible cantilever. The drive assembly is configured for displacing a distal end of the optical fiber about a fulcrum in accordance with a scan pattern, such that the emitted light diverges from a longitudinal axis coincident with the fulcrum. The display subsystem further comprises an optical modulation apparatus configured for converging the light from the optical fiber towards the longitudinal axis, and an optical waveguide input apparatus configured for directing the light from the optical modulation apparatus down the planar waveguide apparatus, such that the planar waveguide apparatus displays one or more image frames to an end user.

(12) INTERNATIONAL APPLICATION PUBLISHED UNDER THE PATENT COOPERATION TREATY (PCT)

(19) World Intellectual Property
Organization
International Bureau(10) International Publication Number
WO 2017/062667 A1(43) International Publication Date
13 April 2017 (13.04.2017)

- (51) **International Patent Classification:**
G02B 5/18 (2006.01) *G02B 6/10* (2006.01)
- (21) **International Application Number:** PCT/US2016/055823
- (22) **International Filing Date:** 6 October 2016 (06.10.2016)
- (25) **Filing Language:** English
- (26) **Publication Language:** English
- (30) **Priority Data:** 62/238,052 6 October 2015 (06.10.2015) US
- (71) **Applicant:** **MAGIC LEAP, INC.** [US/US]; 1855 Griffin Rd B454, Dania Beach, Florida 33004 (US).
- (72) **Inventors:** **YEOH, Ivan L.**; 845 N Victoria Park Rd #3, Fort Lauderdale, Florida 33304 (US). **CHENG, Hui-Chuan**; 10234 SW 58th Street, Cooper City, Florida 33328 (US). **EDWIN, Lionel Ernest**; 1051 South Park Road, Apt. 207, Hollywood, Florida 33021 (US). **TINCH, David**; 3756 SW 50th Street, Fort Lauderdale, Florida 33312 (US). **WELCH, William Hudson**; 1617 NE 3rd Court, Fort Lauderdale, Florida 33301 (US).
- (74) **Agents:** **MEI, Peter C.** et al.; Vista Ip Law Group LLP, 2160 Lundy Ave., Suite 230, San Jose, California 95131 (US).
- (81) **Designated States** (*unless otherwise indicated, for every kind of national protection available*): AE, AG, AL, AM, AO, AT, AU, AZ, BA, BB, BG, BH, BN, BR, BW, BY, BZ, CA, CH, CL, CN, CO, CR, CU, CZ, DE, DJ, DK, DM, DO, DZ, EC, EE, EG, ES, FI, GB, GD, GE, GH, GM, GT, HN, HR, HU, ID, IL, IN, IR, IS, JP, KE, KG, KN, KP, KR, KW, KZ, LA, LC, LK, LR, LS, LU, LY, MA, MD, ME, MG, MK, MN, MW, MX, MY, MZ, NA, NG, NI, NO, NZ, OM, PA, PE, PG, PH, PL, PT, QA, RO, RS, RU, RW, SA, SC, SD, SE, SG, SK, SL, SM, ST, SV, SY, TH, TJ, TM, TN, TR, TT, TZ, UA, UG, US, UZ, VC, VN, ZA, ZM, ZW.
- (84) **Designated States** (*unless otherwise indicated, for every kind of regional protection available*): ARIPO (BW, GH, GM, KE, LR, LS, MW, MZ, NA, RW, SD, SL, ST, SZ, TZ, UG, ZM, ZW), Eurasian (AM, AZ, BY, KG, KZ, RU, TJ, TM), European (AL, AT, BE, BG, CH, CY, CZ, DE, DK, EE, ES, FI, FR, GB, GR, HR, HU, IE, IS, IT, LT, LU, LV, MC, MK, MT, NL, NO, PL, PT, RO, RS, SE, SI, SK,

[Continued on next page]

(54) **Title:** VIRTUAL/AUGMENTED REALITY SYSTEM HAVING REVERSE ANGLE DIFFRACTION GRATING

FIG. 1

(57) **Abstract:** A display subsystem for a virtual image generation system comprises a planar waveguide apparatus, an optical fiber, at least one light source configured for emitting light from a distal end of the optical fiber, and a mechanical drive assembly to which the optical fiber is mounted as a fixed-free flexible cantilever. The drive assembly is configured for displacing a distal end of the optical fiber about a fulcrum in accordance with a scan pattern, such that the emitted light diverges from a longitudinal axis coincident with the fulcrum. The display subsystem further comprises an optical modulation apparatus configured for converging the light from the optical fiber towards the longitudinal axis, and an optical waveguide input apparatus configured for directing the light from the optical modulation apparatus down the planar waveguide apparatus, such that the planar waveguide apparatus displays one or more image frames to an end user.

 WO 2017/062667 A1

WO 2017/062667 A1 

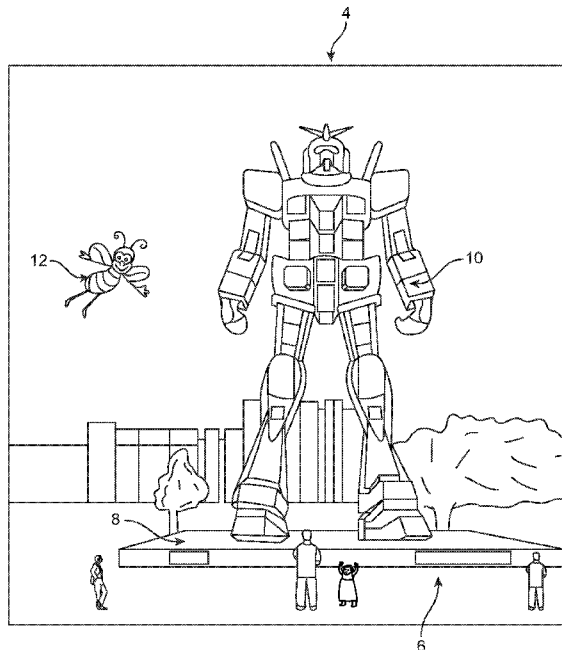
SM, TR), OAPI (BF, BJ, CF, CG, CI, CM, GA, GN, GQ, GW, KM, ML, MR, NE, SN, TD, TG). **Published:**

— *with international search report (Art. 21(3))*

WO 2017/062667

PCT/US2016/055823

VIRTUAL/AUGMENTED REALITY SYSTEM HAVING REVERSE ANGLE DIFFRACTION GRATING

FIELD OF THE INVENTION

[0001] The invention generally relates to systems and methods configured to facilitate interactive virtual or augmented reality environments for one or more users.

BACKGROUND

[0002] Modern computing and display technologies have facilitated the development of systems for so-called “virtual reality” or “augmented reality” experiences, wherein digitally reproduced images or portions thereof are presented to a user in a manner where they seem to be, or may be perceived as, real. A virtual reality (VR) scenario typically involves presentation of digital or virtual image information without transparency to other actual real-world visual input, whereas an augmented reality (AR) scenario typically involves presentation of digital or virtual image information as an augmentation to visualization of the actual world around the end user.

[0003] For example, referring to Fig. 1, an augmented reality scene 4 is depicted wherein a user of an AR technology sees a real-world park-like setting 6 featuring people, trees, buildings in the background, and a concrete platform 8. In addition to these items, the end user of the AR technology also perceives that he “sees” a robot statue 10 standing upon the real-world platform 8, and a cartoon-like avatar character 12 flying by which seems to be a personification of a bumble bee, even though these elements 10, 12 do not exist in the real world. As it turns out, the human visual perception system is very complex, and producing a VR or AR technology that

facilitates a comfortable, natural-feeling, rich presentation of virtual image elements amongst other virtual or real-world imagery elements is challenging.

[0004] VR and AR systems typically employ head-worn displays (or helmet-mounted displays, or smart glasses) that are at least loosely coupled to a user's head, and thus move when the end user's head moves. If the end user's head motions are detected by the display system, the data being displayed can be updated to take the change in head pose (i.e., the orientation and/or location of user's head) into account.

[0005] As an example, if a user wearing a head-worn display views a virtual representation of a three-dimensional (3D) object on the display and walks around the area where the 3D object appears, that 3D object can be re-rendered for each viewpoint, giving the end user the perception that he or she is walking around an object that occupies real space. If the head-worn display is used to present multiple objects within a virtual space (for instance, a rich virtual world), measurements of head pose can be used to re-render the scene to match the end user's dynamically changing head location and orientation and provide an increased sense of immersion in the virtual space.

[0006] Head-worn displays that enable AR (i.e., the concurrent viewing of real and virtual elements) can have several different types of configurations. In one such configuration, often referred to as a "video see-through" display, a camera captures elements of a real scene, a computing system superimposes virtual elements onto the captured real scene, and a non-transparent display presents the composite image to the eyes. Another configuration is often referred to as an "optical see-through" display, in which the end user can see through transparent (or semi-transparent) elements in the

display system to view directly the light from real objects in the environment. The transparent element, often referred to as a “combiner,” superimposes light from the display over the end user’s view of the real world.

[0007] VR and AR systems typically employ a display system having a projection subsystem and a display surface positioned in front of the end user’s field of view and on which the projection subsystem sequentially projects image frames. In true three-dimensional systems, the depth of the display surface can be controlled at frame rates or sub-frame rates. The projection subsystem may include one or more optical fibers into which light from one or more light sources emit light of different colors in defined patterns, and a scanning device that scans the optical fiber(s) in a predetermined pattern to create the image frames that sequentially displayed to the end user.

[0008] In one embodiment, the display system includes one or more planar waveguides that are generally parallel to the field of view of the user, and into which light from the optical fiber(s) is injected. One or more linear diffraction gratings are embedded within the waveguide(s) to change the angle of incident light propagating along the waveguide(s). By changing the angle of light beyond the threshold of total internal reflection (TIR), the light escapes from one or more lateral faces of the waveguide(s). The linear diffraction grating(s) have a low diffraction efficiency, so only a fraction of the light energy is directed out of the waveguide(s), each time the light encounters the linear diffraction grating(s). By outcoupling the light at multiple locations along the grating(s), the exit pupil of the display system is effectively increased. The display system may further comprise one or more collimation elements that collimate light coming from the

optical fiber(s), and one or more optical coupling elements that optically couple the collimated light to, or from, an edge of the waveguide(s).

[0009] In a typical optical fiber scanning display system, each optical fiber acts as a vibrating cantilever that sweeps through relatively large deflections from a fulcrum in order to scan the light in accordance with a designed scan pattern. However, due to the large deflections of the collimated light, the size of the optical coupling element(s) must be relatively large, thereby increasing the size of the display system. This size of the optical coupling element(s) becomes more problematic in the case of a stacked waveguide architecture, which requires the optical element(s) associated with the waveguides that are more distance from the scanning optical fiber(s) to be larger to accommodate the larger span of the scanned collimated light.

[0010] For example, with reference to Fig. 2, one embodiment of a display system 20 comprises one or more light sources 22 that generate image data that is encoded in the form of light that is spatially and/or temporally varying, an optical fiber 24 optically coupled to the light source(s) 22, and a collimation element 26 that collimates the light exiting the distal end of the optical fiber 24. The display system 20 further comprises a piezoelectric element 28 to or in which the optical fiber 24 is mounted as a fixed-free flexible cantilever, and drive electronics 30 electrically coupled to the piezoelectric element 22 to activate electrically stimulate the piezoelectric element 28, thereby causing the distal end of the optical fiber 24 to vibrate in a pre-determined scan pattern that creates deflections 32 about a fulcrum 34.

[0011] The display system 20 includes a waveguide apparatus 38 that includes a plurality of planar waveguides 40a-40e that are generally parallel to the field-of-view of

the end user, and one or more diffractive optical elements (DOEs) 42a-42e associated with each of the planar waveguides 40. Light originating from the optical fiber 24 propagates along selected ones of the planar waveguides 40 and intersects with the corresponding DOEs 42, causing a portion of the light to exit the face of the waveguide apparatus 38 towards the eyes of the end user that is focused at one or more viewing distances depending on the selected planar waveguide(s) 40.

[0012] The display system 20 further comprises optical coupling elements in the form of diffractive optical elements (DOEs) 44a-44e that are integrated within the ends of the respective planar waveguides 40a-40e and that reflect the collimate light into selected ones of the planar waveguides 40. As can be seen, as the distance between each DOE 44 and the end of the optical fiber 24 increases, the length of the respective DOE 44 must increase in order to accommodate the increasing linear span of the deflection angle of the optical fiber 24. This necessarily adds size and complexity to the waveguide apparatus 38 due to the largest DOE 44, and in this case, the DOE 44e.

[0013] As another example, with reference to Fig. 3, another embodiment of a display system 50 is similar to the display system 10 of Fig. 2, with the exception that the display system 50 comprises an optical coupling element in the form of an optical distribution waveguide 52 that have DOEs 54a-54e that reflect the collimate light into selected ones of the planar waveguides 40. The width of the distribution waveguide 52 must be large enough to accommodate the maximum linear span of the deflection angle of the optical fiber 24, thereby necessarily adding size and complexity to the waveguide apparatus 38.

[0014] There, thus, is a need to reduce the size of optical coupling element(s) used to couple light from one or more optical fibers into one or more planar waveguides in a virtual reality or augmented reality environment.

SUMMARY

[0015] Embodiments of the invention are directed to devices, systems and methods for facilitating virtual reality and/or augmented reality interaction for one or more users.

[0016] In accordance with the invention, a display subsystem for a virtual image generation system for use by an end user is provided. The virtual image generation system may, e.g., comprise memory storing a three-dimensional scene, and a control subsystem configured for rendering a plurality of synthetic image frames of the three-dimensional scene, in which case, the display subsystem may be configured for sequentially displaying the plurality of image frames to the end user.

[0017] The display subsystem comprises a planar waveguide apparatus, an optical fiber, and at least one light source configured for emitting light from a distal end of the optical fiber. In one embodiment, the planar waveguide apparatus is configured for being positioned in front of the eyes of the end user. The planar waveguide apparatus may have a partially transparent display surface configured for being positioned in the field of view between the eyes of the end user and an ambient environment. In one embodiment, the display subsystem may further comprise a frame structure configured for being worn by the end user, in which case, the frame structure may carry the planar waveguide apparatus.

[0018] The display subsystem further comprises a mechanical drive assembly to which the optical fiber is mounted as a fixed-free flexible cantilever. The drive assembly is configured for displacing a distal end of the optical fiber about a fulcrum in accordance with a scan pattern, such that the outputted/emitted light diverges from a longitudinal axis coincident with the fulcrum. In one embodiment, the mechanical drive assembly comprises a piezoelectric element to which the optical fiber is mounted, and drive electronics configured for conveying electrical signals to the piezoelectric element, thereby causing the optical fiber to vibrate in accordance with the scan pattern. The display subsystem may optionally further comprise a collimation element configured for collimating light from the optical fiber.

[0019] The display subsystem further comprises an optical modulation apparatus configured for converging the light from the optical fiber towards the longitudinal axis. In one embodiment, the optical modulation apparatus is configured for converging the light on a focal point on the longitudinal axis. The focal point may be, e.g., located within the optical waveguide input apparatus, such as the center of the optical waveguide input apparatus along the longitudinal axis. The optical modulation apparatus may, e.g., comprise at least one diffraction grating. Each of the diffraction grating(s) may have a diffraction pattern that matches the geometry of the scan pattern. For example, if the scan pattern is a spiral scan pattern, the diffraction pattern may be a spiral diffraction pattern. In another embodiment, the optical modulation apparatus comprises two orthogonal diffraction gratings in series, such that one of the diffraction gratings diffracts light along a first axis, and another one of the diffraction gratings diffracts light along a second axis orthogonal to the first axis.

[0020] The display subsystem further comprises an optical waveguide input apparatus configured for directing the light from the optical modulation apparatus down the planar waveguide apparatus, such that the planar waveguide apparatus displays one or more image frames to the end user. In one embodiment, the planar waveguide apparatus comprises a plurality of planar waveguides configured for respectively displaying the image frame(s) at different focal points to the end user, in which case, the optical waveguide input apparatus may be configured for directing the light down selected ones of the plurality of planar waveguides. In another embodiment, the optical waveguide input apparatus comprises a plurality of diffractive optical elements respectively extending parallel along the planar waveguides, and respectively directing the light from the optical modulation apparatus down the planar waveguides. In still another embodiment, the optical waveguide input apparatus comprises a distribution waveguide extending perpendicularly to the planar waveguides, and the distribution waveguide comprises a plurality of diffractive optical elements that respectively direct the light from the optical modulation apparatus down the planar waveguides.

[0021] Additional and other objects, features, and advantages of the invention are described in the detail description, figures and claims.

BRIEF DESCRIPTION OF THE DRAWINGS

[0022] The drawings illustrate the design and utility of embodiment of the invention, in which similar elements are referred to by common reference numerals. In order to better appreciate how the above-recited and other advantages and objects of the invention are obtained, a more particular description of the invention briefly described above will be

rendered by reference to specific embodiments thereof, which are illustrated in the accompanying drawings. Understanding that these drawings depict only typical embodiments of the invention and are not therefore to be considered limiting of its scope, the invention will be described and explained with additional specificity and detail through the use of the accompanying drawings in which:

[0023] Fig. 1 is a picture of a three-dimensional augmented reality scene that can be displayed to an end user by a prior art augmented reality generation device;

[0024] Fig. 2 is a plan view of one embodiment of a prior art display system that can be used in an augmented reality generation device;

[0025] Fig. 3 is a plan view of another embodiment of a prior art display system that can be used in an augmented reality generation device;

[0026] Fig. 4 is a block diagram of a virtual image generation system constructed in accordance with one embodiment;

[0027] Fig. 5 is a plan view of an exemplary frame generated by the virtual image generation system of Fig. 4.

[0028] Fig. 6 is a plan view of one scanning pattern that can be used to generate a frame;

[0029] Fig. 7 is a plan view of another scanning pattern that can be used to generate a frame;

[0030] Fig. 8 is a plan view of still another scanning pattern that can be used to generate a frame;

[0031] Fig. 9 is a plan view of yet another scanning pattern that can be used to generate a frame;

[0032] Fig. 10a is a plan view of one technique that can be used to wear the virtual image generation system of Fig. 4;

[0033] Fig. 10b is a plan view of another technique that can be used to wear the virtual image generation system of Fig. 4;

[0034] Fig. 10c is a plan view of still another technique that can be used to wear the virtual image generation system of Fig. 4;

[0035] Fig. 10d is a plan view of yet another technique that can be used to wear the virtual image generation system of Fig. 4;

[0036] Fig. 11 is a plan view of one embodiment of a display subsystem for use in the virtual image generation system of Fig. 4;

[0037] Fig. 12 is one embodiment of a primary planar waveguide for use in the display subsystem of Fig. 11;

[0038] Fig. 13a is perspective view of one embodiment of a display subsystem for use in the virtual image generation system of Fig. 4;

[0039] Fig. 13b is a perspective view of the display subsystem of Fig. 13a, particularly showing light rays extending from one focal point;

[0040] Fig. 13c is a perspective view of the display subsystem of Fig. 13a, particularly showing light rays extending from another focal point;

[0041] Fig. 14 is a plan view of another embodiment of a display subsystem for use in the virtual image generation system of Fig. 4;

[0042] Fig. 15 is a plan view of one embodiment of a planar waveguide apparatus for use in the display subsystem of Fig. 13;

[0043] Fig. 16 is a plan view of another embodiment of a planar waveguide apparatus for use in the display subsystem of Fig. 13;

[0044] Fig. 17 is a profile view of the planar waveguide apparatus of Fig. 16;

[0045] Fig. 18a is a plan view of one embodiment of an optical coupling subsystem and scanning device that can be used in the display subsystem of Fig. 13, particularly showing the convergence of light beams onto a focal point in the center of the optical waveguide input apparatus;

[0046] Fig. 18b is a plan view of the optical coupling subsystem and scanning device of Fig. 18a, particularly showing the convergence of light beams onto a focal point at the edge of the optical waveguide input apparatus;

[0047] Fig. 19 is a plan view of one embodiment of an optical waveguide input apparatus for use in the optical coupling subsystem of Fig. 13a;

[0048] Fig. 20 is a plan view of another embodiment of an optical waveguide input apparatus for use in the optical coupling subsystem of Fig. 13a;

[0049] Fig. 21 is a plan view of a spiral diffraction pattern that can be used in an optical modulation apparatus in the optical coupling subsystem of Fig. 18a;

[0050] Fig. 22a is one embodiment of an optical modulation apparatus that can be used in the optical coupling subsystem of Fig. 18a; and

[0051] Fig. 22b is another embodiment of an optical modulation apparatus that can be used in the optical coupling subsystem of Fig. 18a.

DETAILED DESCRIPTION

[0052] The description that follows relates to display systems and methods to be used in virtual reality and/or augmented reality systems. However, it is to be understood that the while the invention lends itself well to applications in virtual or augmented reality systems, the invention may not be so limited.

[0053] Referring to Fig. 4, one embodiment of a virtual image generation system 100 constructed in accordance with invention will now be described. The virtual image generation system 100 may be operated as an augmented reality subsystem, providing images of virtual objects intermixed with physical objects in a field of view of an end user 50. There are two fundamental approaches when operating the virtual image generation system 100. A first approach employs one or more imagers (e.g., cameras) to capture images of the ambient environment. The virtual image generation system 100 inter-mixes the virtual images into the data representing the images of the ambient environment. A second approach employs one or more at least partially transparent surfaces through which the ambient environment can be seen and on to which the virtual image generation system 100 produces images of virtual objects.

[0054] The virtual image generation system 100, and the various techniques taught herein, may be employed in applications other than augmented reality and virtual reality subsystems. For example, various techniques may be applied to any projection or display subsystem, or may be applied to pico projectors where movement may be made by an end user's hand rather than the head. Thus, while often described herein in terms of an augmented reality subsystem or virtual reality subsystem, the teachings should not be limited to such subsystems of such uses.

DETAILED DESCRIPTION

[0052] The description that follows relates to display systems and methods to be used in virtual reality and/or augmented reality systems. However, it is to be understood that the while the invention lends itself well to applications in virtual or augmented reality systems, the invention may not be so limited.

[0053] Referring to Fig. 4, one embodiment of a virtual image generation system 100 constructed in accordance with invention will now be described. The virtual image generation system 100 may be operated as an augmented reality subsystem, providing images of virtual objects intermixed with physical objects in a field of view of an end user 50. There are two fundamental approaches when operating the virtual image generation system 100. A first approach employs one or more imagers (e.g., cameras) to capture images of the ambient environment. The virtual image generation system 100 inter-mixes the virtual images into the data representing the images of the ambient environment. A second approach employs one or more at least partially transparent surfaces through which the ambient environment can be seen and on to which the virtual image generation system 100 produces images of virtual objects.

[0054] The virtual image generation system 100, and the various techniques taught herein, may be employed in applications other than augmented reality and virtual reality subsystems. For example, various techniques may be applied to any projection or display subsystem, or may be applied to pico projectors where movement may be made by an end user's hand rather than the head. Thus, while often described herein in terms of an augmented reality subsystem or virtual reality subsystem, the teachings should not be limited to such subsystems of such uses.

images. The display screen 110 is positioned in the end user's 50 field of view between the eyes 52 of the end user 50 and an ambient environment.

[0058] In the illustrated embodiment, the projection subsystem 108 takes the form of an optical fiber scan-based projection device, and the display screen 110 takes the form of a waveguide-based display into which the scanned light from the projection subsystem 108 is injected to produce, e.g., images at single optical viewing distance closer than infinity (e.g., arm's length), images at multiple, discrete optical viewing distances or focal planes, and/or image layers stacked at multiple viewing distances or focal planes to represent volumetric 3D objects. These layers in the light field may be stacked closely enough together to appear continuous to the human visual subsystem (i.e., one layer is within the cone of confusion of an adjacent layer). Additionally or alternatively, picture elements may be blended across two or more layers to increase perceived continuity of transition between layers in the light field, even if those layers are more sparsely stacked (i.e., one layer is outside the cone of confusion of an adjacent layer). The display subsystem 104 may be monocular or binocular.

[0059] Thus, the display subsystem 104 generates a series of synthetic image frames of pixel information that present an image of one or more virtual objects to the user. For example, referring to Fig. 5, a synthetic image frame 118 is schematically illustrated with cells 120a-120m divided into horizontal rows or lines 122a-122n. Each cell 120 of the frame 118 may specify values for each of a plurality of colors for the respective pixel to which the cell 120 corresponds and/or intensities. For instance, the frame 118 may specify one or more values for red 124a, one or more values for green 124b, and one or more values for blue 124c for each pixel. The values 124 may be specified as binary

representations for each of the colors, for instance, a respective 4-bit number for each color. Each cell 120 of the frame 118 may additionally include a value 124d that specifies an amplitude.

[0060] The frame 118 may include one or more fields, collectively 126. The frame 118 may consist of a single field. Alternatively, the frame 118 may comprise two, or even more fields 126a-126b. The pixel information for a complete first field 126a of the frame 118 may be specified before the pixel information for the complete second field 126b, for example occurring before the pixel information for the second field 126b in an array, an ordered list or other data structure (e.g., record, linked list). A third or even a fourth field may follow the second field 126b, assuming a presentation subsystem is configured to handle more than two fields 126a-126b.

[0061] Referring now to Fig. 6, the frame 118 is generated using a raster scan pattern 128. In the raster scan pattern 128, pixels 130 (only one called out) are sequentially presented. The raster scan pattern 128 typically presents pixels from left to right (indicated by arrows 132a, 132b, then from top to bottom (indicated by arrow 134). Thus, the presentation may start at the upper right corner and traverse left across a first line 136a until the end of the line is reached. The raster scan pattern 128 typically then starts from the left in a next line down. The presentation may be temporarily blacked out or blanked when returning from the end of one line to the start of the next line. This process repeats line-by-line until the bottom line 136n is completed, for example at the bottom right most pixel. With the frame 118 being complete, a new frame is started, again returning the right of the top most line of the next frame. Again, the presentation

may be blanked while returning from the bottom left to the top right to present the next frame.

[0062] Many implementations of raster scanning employ what is termed as an interlaced scan pattern. In interlaced raster scan patterns, lines from the first and the second fields 126a, 126b are interlaced. For example, when presenting lines of the first field 126a, the pixel information for the first field 126a may be used for the odd numbered lines only, while the pixel information for the second field 126b may be used for the even numbered lines only. Thus, all of the lines of the first field 126a of the frame 118 (Fig. 5) are typically presented before the lines of the second field 126b. The first field 126a may be presented using the pixel information of the first field 126a to sequentially present line 1, line 3, line 5, etc. Then the second field 126b of the frame 118 (Fig. 5) may be presented following the first field 126a, by using the pixel information of the second field 126b to sequentially present line 2, line 4, line 6, etc.

[0063] Referring to Fig. 7, a spiral scan pattern 140 may be used instead of the raster scan pattern 128 to generate the frame 118. The spiral scan pattern 140 may consist of a single spiral scan line 142, which may include one or more complete angular cycles (e.g., 360 degrees) which may be denominated as coils or loops. As with the raster scan pattern 128 illustrated in Fig. 6, the pixel information in the spiral scan pattern 140 is used to specify the color and/or intensity of each sequential pixel, as the angle increments. An amplitude or radial value 146 specifies a radial dimension from a starting point 148 of the spiral scan line 142.

[0064] Referring to Fig. 8, a Lissajous scan pattern 150 may alternatively be used to generate the frame 118. The Lissajous scan pattern 150 may consist of a single

Lissajous scan line 152, which may include one or more complete angular cycles (e.g., 360 degrees), which may be denominated as coils or loops. Alternatively, the Lissajous scan pattern 150 may include two or more Lissajous scan lines 152, each phase shifted with respect to one another to nest the Lissajous scan lines 152. The pixel information is used to specify the color and/or intensity of each sequential pixel, as the angle increments. An amplitude or radial value specifies a radial dimension 154 from a starting point 156 of the Lissajous scan line 152.

[0065] Referring to Fig. 9, a multi-field spiral scan pattern 158 may alternatively be used to generate the frame 118. The multi-field spiral scan pattern 158 includes two or more distinct spiral scan lines, collectively 160, and in specifically, four spiral scan lines 160a-160d. The pixel information for each spiral scan line 160 may be specified by a respective field of a frame. Advantageously, multiple spiral scan lines 160 may be nested simply by shifting a phase between each successive ones of the spiral scan lines 160. The phase difference between spiral scan lines 160 should be a function of the total number of spiral scan lines 160 that will be employed. For example, four spiral scan lines 160a-160d may be separated by a 90 degree phase shift. An exemplary embodiment may operate at a 100 Hz refresh rate with 10 distinct spiral scan lines (i.e., subspirals). Similar to the embodiment of Fig. 7, one or more amplitude or radial values specify a radial dimension 162 from a starting point 164 of the spiral scan lines 160.

[0066] Referring back to Fig. 4, the virtual image generation system 100 further comprises one or more sensors (not shown) mounted to the frame structure 102 for detecting the position and movement of the head 54 of the end user 50 and/or the eye position and inter-ocular distance of the end user 50. Such sensor(s) may include

WO 2017/062667

PCT/US2016/055823

image capture devices (such as cameras), microphones, inertial measurement units, accelerometers, compasses, GPS units, radio devices, and/or gyros).

[0067] For example, in one embodiment, the virtual image generation system 100 comprises a head worn transducer subsystem 126 that includes one or more inertial transducers to capture inertial measures indicative of movement of the head 54 of the end user 50. Such may be used to sense, measure, or collect information about the head movements of the end user 50. For instance, such may be used to detect measurement movements, speeds, acceleration, and/or positions of the head 54 of the end user 50.

[0068] The virtual image generation system 100 further comprises one or more forward facing cameras 128, which may be used to capture information about the environment in which the end user 50 is located. The forward facing camera(s) 128 may be used to capture information indicative of distance and orientation of the end user 50 with respect to that environment and specific objects in that environment. When head worn, the forward facing camera(s) 128 is particularly suited to capture information indicative of distance and orientation of the head 54 of the end user 50 with respect to the environment in which the end user 50 is located and specific objects in that environment. The forward facing camera(s) 128 may, for example, be employed to detect head movement, speed, and/or acceleration of head movements. The forward facing camera(s) 128 may, for example, be employed to detect or infer a center of attention of the end user 50, for example, based at least in part on an orientation of the head 54 of the end user 50. Orientation may be detected in any direction (e.g., up/down, left, right with respect to the reference frame of the end user 50).

[0069] The virtual image generation system 100 further comprises a pair of rearward facing cameras 129 to track movement, blinking, and depth of focus of the eyes 52 of the end user 50. Such eye tracking information may, for example, be discerned by projecting light at the end user's eyes, and detecting the return or reflection of at least some of that projected light.

[0070] The virtual image generation system 100 further comprises a user orientation detection module 130. The patient orientation module 130 detects the instantaneous position of the head 54 of the end user 50 and may predict the position of the head 54 of the end user 50 based on position data received from the sensor(s). Significantly, detecting the instantaneous position of the head 54 of the end user 50 facilitates determination of the specific actual object that the end user 50 is looking at, thereby providing an indication of the specific textual message to be generated for that actual object and further providing an indication of the textual region in which the textual message is to be streamed. The patient orientation module 130 also tracks the eyes 52 of the end user 50 based on the tracking data received from the sensor(s).

[0071] The virtual image generation system 100 further comprises a control subsystem that may take any of a large variety of forms. The control subsystem includes a number of controllers, for instance one or more microcontrollers, microprocessors or central processing units (CPUs), digital signal processors, graphics processing units (GPUs), other integrated circuit controllers, such as application specific integrated circuits (ASICs), programmable gate arrays (PGAs), for instance field PGAs (FPGAs), and/or programmable logic controllers (PLUs).

WO 2017/062667

PCT/US2016/055823

[0072] In the illustrated embodiment, the virtual image generation system 100 comprises a central processing unit (CPU) 132, a graphics processing unit (GPU) 134, and one or more frame buffers 136. The CPU 132 controls overall operation, while the GPU 134 renders frames (i.e., translating a three-dimensional scene into a two-dimensional image) from three-dimensional data stored in the remote data repository 150 and stores these frames in the frame buffer(s) 136. While not illustrated, one or more additional integrated circuits may control the reading into and/or reading out of frames from the frame buffer(s) 136 and operation of the scanning device of the display subsystem 104. Reading into and/or out of the frame buffer(s) 146 may employ dynamic addressing, for instance, where frames are over-rendered. The virtual image generation system 100 further comprises a read only memory (ROM) 138 and a random access memory (RAM) 140. The virtual image generation system 100 further comprises a three-dimensional data base 142 from which the GPU 134 can access three-dimensional data of one or more scenes for rendering frames.

[0073] The various processing components of the virtual image generation system 100 may be physically contained in a distributed subsystem. For example, as illustrated in Figs. 10a-10d, the virtual image generation system 100 comprises a local processing and data module 144 operatively coupled, such as by a wired lead or wireless connectivity 146, to the display subsystem 104 and sensors. The local processing and data module 144 may be mounted in a variety of configurations, such as fixedly attached to the frame structure 102 (Fig. 10a), fixedly attached to a helmet or hat 56 (Fig. 10b), embedded in headphones, removably attached to the torso 58 of the end user 50 (Fig. 10c), or removably attached to the hip 60 of the end user 50 in a belt-

coupling style configuration (Fig. 10d). The virtual image generation system 100 further comprises a remote processing module 148 and remote data repository 150 operatively coupled, such as by a wired lead or wireless connectivity 150, 152, to the local processing and data module 144, such that these remote modules 148, 150 are operatively coupled to each other and available as resources to the local processing and data module 144.

[0074] The local processing and data module 144 may comprise a power-efficient processor or controller, as well as digital memory, such as flash memory, both of which may be utilized to assist in the processing, caching, and storage of data captured from the sensors and/or acquired and/or processed using the remote processing module 148 and/or remote data repository 150, possibly for passage to the display subsystem 104 after such processing or retrieval. The remote processing module 148 may comprise one or more relatively powerful processors or controllers configured to analyze and process data and/or image information. The remote data repository 150 may comprise a relatively large-scale digital data storage facility, which may be available through the internet or other networking configuration in a "cloud" resource configuration. In one embodiment, all data is stored and all computation is performed in the local processing and data module 144, allowing fully autonomous use from any remote modules.

[0075] The couplings 146, 152, 154 between the various components described above may include one or more wired interfaces or ports for providing wires or optical communications, or one or more wireless interfaces or ports, such as via RF, microwave, and IR for providing wireless communications. In some implementations, all communications may be wired, while in other implementations all communications may

be wireless. In still further implementations, the choice of wired and wireless communications may be different from that illustrated in Figs. 10a-10d. Thus, the particular choice of wired or wireless communications should not be considered limiting.

[0076] In the illustrated embodiment, the patient orientation module 130 is contained in the local processing and data module 144, while CPU 132 and GPU 134 are contained in the remote processing module 148, although in alternative embodiments, the CPU 132, GPU 134, or portions thereof may be contained in the local processing and data module 144. The 3D database 142 can be associated with the remote data repository 150.

[0077] Referring now to Figs. 11 and 12, the display screen 110 comprises a primary waveguide apparatus 200. The primary waveguide apparatus 200 includes one or more primary planar waveguides 202 (only one shown in Figs. 11 and 12), and one or more diffractive optical elements (DOEs) 204 (only one shown in Figs. 11 and 12) associated with each of at least some of the primary waveguides 202. As best illustrated in Fig. 12, each primary waveguide 202 has a first end 206a and a second end 206b, the second end 206b opposed to the first end 206a along a length 208 of the primary waveguide(s) 202. Each of the primary waveguide(s) 202 has a first face 210a and a second face 210b, at least the first and the second faces 210a, 210b (collectively 210) forming an at least partially internally reflective optical path (illustrated by arrow 212a and broken line arrow 212b, collectively 212) along at least a portion of the length 208 of the primary waveguide(s) 202. The primary waveguide(s) 202 may take a variety of forms that provide for substantially total internal reflection (TIR) for light striking the faces 210 at less than a defined critical angle. Each of the primary waveguide(s) 202 may, for

example, take the form of a pane or plane of glass, fused silica, acrylic, or polycarbonate.

[0078] The DOEs 204 (illustrated in Figs. 11 and 12 by dash-dot double lines) may take a large variety of forms which interrupt the TIR optical path 212, providing a plurality of optical paths (illustrated by arrows 214a and broken line arrows 214b, collectively 214) between an interior 216 and an exterior 218 of the primary waveguide 202 extending along at least a portion of the length 206 of the primary waveguide 202. The DOEs 204 may allow positioning of apparent objects and focus plane for apparent objects. Such may be achieved on a frame-by-frame, subframe-by-subframe, or even pixel-by-pixel basis.

[0079] As illustrated in Fig. 12, the light propagates along the primary waveguide(s) 202 with at least some reflections or "bounces" resulting from the TIR propagation. It is noted that some implementations may employ one or more reflectors in the internal optical path, for instance thin-films, dielectric coatings, metalized coatings, etc., which may facilitate reflection. Light propagates along the length 208 of the primary waveguide(s) 202, and intersects with one or more DOEs 204 at various positions along the length 208. The DOE(s) 204 may be incorporated within the primary waveguides 202 or abutting or adjacent one or more of the faces 210 of the primary waveguide(s) 202. The DOE(s) 204 accomplishes at least two functions. The DOE(s) 204 shift an angle of the light, causing a portion of the light to escape TIR, and emerge from the interior 216 to the exterior 218 via one or more faces 210 of the primary waveguide(s) 202. The DOE(s) 204 focus the out-coupled light at one or more viewing distances.

Thus, someone looking through a face 210a of the primary waveguides 202 can see digital imagery at one or more viewing distances.

[0080] Referring to Figs. 13a-13c, the display screen 110 comprises a distribution waveguide apparatus 222 to relay light along a first axis (vertical or Y-axis in Fig. 11a), and expand the light's effective exit pupil along the first axis (e.g., Y-axis). The distribution waveguide apparatus 222, may, for example include one or more distribution planar waveguides 224 (only one shown) and a DOE 226 (illustrated by double dash-dot line) associated with each of the distribution planar waveguides 224. The distribution planar waveguide 224 may be similar or identical in at least some respects to the primary waveguide 202, having a different orientation therefrom. Likewise, the DOE 226 may be similar or identical in at least some respects to the DOE 204. For example, the distribution planar waveguide 220 and/or DOE 226 may be comprised of the same materials as the primary waveguide 202 and/or DOE 204, respectively.

[0081] The relayed and exit-pupil expanded light is optically coupled from the distribution waveguide apparatus 222 into the primary waveguide 202. The primary waveguide 202 relays light along a second axis, preferably orthogonal to first axis, (e.g., horizontal or X-axis Fig. 13a). Notably, the second axis can be a non-orthogonal axis to the first axis. The primary waveguide 202 expands the light's effective exit pupil along that second axis (e.g. X-axis). In particular, the distribution planar waveguide 224 can relay and expand light along the vertical or Y-axis, and pass that light to the primary waveguide 202, which relays and expands light along the horizontal or X-axis.

[0082] The display screen 110 may generate an image at a single focus plane that is capable of being positioned closer than optical infinity. Collimated light propagates vertically, as shown in Fig. 13b along the distribution planar waveguide 224 by total internal reflection, and in doing so repeatedly intersects with the DOE 226. The DOE 226 preferably has a low diffraction efficiency (e.g., less than 50%). This causes a fraction (e.g., 10%) of the light to be diffracted toward an edge of the larger primary planar waveguide 202 at each point of intersection with the DOE 226, and a fraction of the light to continue on its original trajectory down the length of the distribution planar waveguide 224 via TIR. At each point of intersection with the DOE 226, additional light is diffracted toward the entrance of the primary waveguide 202. By dividing the incoming light into multiple outcoupled sets, the exit pupil of the light is expanded vertically by the DOE 226 in the distribution planar waveguide 224. This vertically expanded light coupled out of distribution planar waveguide 224 enters the edge of the primary waveguide 202.

[0083] Light entering the primary waveguide 202 propagates horizontally (as shown in Fig. 13b) along the primary waveguide 202 via TIR. The light intersects with the DOE 204 at multiple points as it propagates horizontally along at least a portion of the length of the primary waveguide 202 via TIR. The DOE 204 may advantageously be designed or configured to have a phase profile that is a summation of a linear diffraction grating and a radially symmetric diffractive lens. The DOE 204 may advantageously have a low diffraction efficiency. At each point of intersection between the propagating light and the DOE 204, a fraction of the light is diffracted toward the adjacent face of the primary waveguide 202 allowing the light to escape the TIR, and emerge from the face of the

primary waveguide 202. The radially symmetric lens aspect of the DOE 204 additionally imparts a focus level to the diffracted light, both shaping the light wavefront (e.g., imparting a curvature) of the individual beam as well as steering the beam at an angle that matches the designed focus level. As illustrated in Fig. 13b, four beams 228a-228d extend geometrically to a focal point 228, and each beam is advantageously imparted with a convex wavefront profile with a center of radius at the focal point 228 to produce an image or virtual object 230a at a given focal plane.

[0084] With reference to Fig. 13c, the display screen 110 may generate a multi-focal volumetric display, image or light field. A first set of four beams 228a-228d extends geometrically to a focal point 230a, and each beam 228a-228d is advantageously imparted with a convex wavefront profile with a center of radius at the focal point 230a to produce another portion of the image or virtual object 232a at a respective focal plane. A second set of four beams 228e-228h extends geometrically to a focal point 230b, and each beam 228e-228h is advantageously imparted with a convex wavefront profile with a center of radius at focal point 230b to produce another portion of the image or virtual object 232b at a respective focal plane.

[0085] In the embodiments of the display subsystem 104 illustrated in Figs. 11-13, a single projection subsystem 108 is used to provide image data to the display screen 110. In contrast to the display system illustrated in Figs. 11-13, the display subsystem 104 may comprise a plurality of projection subsystems 108a-108e (only five shown, collectively 108) to provide respective image data to the display screen 110, as illustrated in Fig. 14. The projection subsystems 108 are generally arrayed or arranged along an edge 234 of the display screen 110. There may, for

example, be a one to one (1:1) ratio or correlation between the number of planar waveguides 202 and the number of projection subsystems 108.

[0086] The display subsystem 104 can enable the use of a single primary planar waveguide 202. The multiple projection subsystems 108 can be disposed, for example, in a linear array along the edge 234 of a primary planar waveguide 202 that is closest to a temple of the end user's head. Each projection subsystem 108 injects modulated light encoding sub-image data into the primary planar waveguide 202 from a different respective position, thus generating different pathways of light. These different pathways can cause the light to be coupled out of the primary planar waveguide 202 by a multiplicity of DOEs at different angles, focus levels, and/or yielding different fill patterns at the exit pupil. Different fill patterns at the exit pupil can be beneficially used to create a light field display. Each layer in the stack or in a set of layers (e.g., 3 layers) in the stack may be employed to generate a respective color (e.g., red, blue, green). Thus, for example, a first set of three adjacent layers may be employed to respectively produce red, blue and green light at a first focal depth. A second set of three adjacent layers may be employed to respectively produce red, blue and green light at a second focal depth. Multiple sets may be employed to generate a full 3D or 4D color image field with various focal depths.

[0087] Referring now to Fig. 15, each planar waveguide 202 may include a plurality of DOEs 204a-204d (four illustrated, each as a double dash-dot line, collectively 204). The DOEs 204 are stacked, arrayed, or arranged along an axis 236 that is generally parallel to the field-of-view of the display screen 110. While illustrated as all being in the

WO 2017/062667

PCT/US2016/055823

interior, in some implementations one, more or even all of the DOEs 204 may be on an exterior of the primary waveguide 202.

[0088] In some implementations, each DOE 204 may be capable of being independently switched ON and OFF. That is, each DOE 204 can be made active, such that the respective DOE 204 diffracts a significant fraction of light that intersects with the respective DOE 204, or it can be rendered inactive such that the respective DOE 204 either does not diffract light intersecting with the respective DOE 204 at all, or only diffracts an insignificant fraction of light. “Significant” in this context means enough light to be perceived by the human visual system when coupled out of the primary waveguide 202, and “insignificant” means not enough light to be perceived by the human visual system, or a low enough level to be ignored by a viewer.

[0089] The switchable DOEs 204 may be switched on one at a time, such that only one DOE 204 in the primary planar waveguide 202 is actively diffracting the light in the primary planar waveguide 202, to emerge from one or more faces 210 of the primary planar waveguide 202 in a perceptible amount. Alternatively, two or more DOEs 204 may be switched ON simultaneously, such that their diffractive effects are combined.

[0090] Each DOE 204 in the set of DOEs can have a different phase map. For example, each DOE 204 can have a respective phase map such that each DOE 204, when switched ON, directs light to a different position in X, Y, or Z. The DOEs 204 may, for example, vary from one another in their linear grating aspect and/or their radially symmetric diffractive lens aspect. If the DOEs 204 vary from one another in their diffractive lens aspect, different DOEs 204 (or combinations of DOEs 204) will produce sub-images at different optical viewing distances—i.e., different focus distances. If the

DOEs 204 vary from one another in their linear grating aspect, different DOEs 204 will produce sub-images that are shifted laterally relative to one another. Such lateral shifts can be beneficially used to create a foveated display, to steer a display image with non-homogenous resolution or other non-homogenous display parameters (e.g., luminance, peak wavelength, polarization, etc.) to different lateral positions, to increase the size of the scanned image, to produce a variation in the characteristics of the exit pupil, and/or to generate a light field display. Lateral shifts may be advantageously employed to preform tiling or realize a tiling effect in generated images.

[0091] For example, a first DOE 204 in the set, when switched ON, may produce an image at an optical viewing distance of 1 meter (e.g., focal point 230b in Fig. 13c) for a viewer looking into the primary or emission face 210a of the primary waveguide 202. A second DOE 204 in the set, when switched ON, may produce an image at an optical viewing distance of 1.25 meters (e.g., focal point 230a in Fig. 13b) for a viewer looking into the primary or emission face 210a of the primary waveguide 202. By switching exemplary DOEs 204 ON and OFF in rapid temporal sequence (e.g., on a frame-by-frame basis, a sub-frame basis, a line-by-line basis, a sub-line basis, pixel-by-pixel basis, or sub-pixel-by-sub-pixel basis) and synchronously modulating the image data being injected into the primary waveguide 202 by the projection subsystem 108, a composite multi-focal volumetric image is formed that is perceived to be a single scene to the viewer. By rendering different objects or portions of objects to sub-images relayed to the eye of the viewer (at location 232b in Fig. 13c) by the different DOEs 204, virtual objects or images are placed at different optical viewing distances, or a virtual

object or image can be represented as a 3D volume that extends through multiple planes of focus.

[0092] Referring now to Fig. 16, the display screen 110 may comprise a plurality of planar waveguides 202a-202d (four shown, collectively 202). The primary waveguides 202a-200d are stacked, arrayed, or arranged along an axis 236 that is generally parallel to the field-of-view of the display screen 110. Each of the primary waveguides 202 includes at least one DOE 204 (illustrated by dash-dot double line, only one called out in Fig. 16). While illustrated as all being in the interior, in some implementations one, more or even all of the DOEs 204 may be on an exterior of the primary waveguides 202. Additionally or alternatively, while illustrated with a single linear array of DOEs 204 per planar waveguide 202, one or more of the primary waveguides 202 may include two or more stacked, arrayed or arranged DOEs 204, similar to the implementation described with respect to Fig. 15.

[0093] Each of the primary waveguides 202 may function analogously to the operation of the DOEs 204 in the embodiment of Fig. 15. That is, the DOEs 204 of the respective planar waveguides 202 may each have a respective phase map, the phase maps of the various DOEs 204 being different from one another. While dynamic switching (e.g., ON/OFF) of the DOEs 204 was employed in the embodiment of Fig. 15, such can be avoided in the embodiment of Fig. 16. Instead of, or in addition to dynamic switching, the display system 110 may selectively route light to the primary waveguides 202 based on the respective phase maps. Thus, rather than turning ON a specific DOE 204 having a desired phase map, the display system 110 may route light to a specific planar waveguide 202 that has or is associated with a DOE 204 with the desired phase

mapping. Again, this may be in lieu of, or in addition to, dynamic switching of the DOEs 204.

[0094] In one example, the projection subsystems may be selectively operated to selectively route light to the primary waveguides 202 based on the respective phase maps. In another example, each DOE 204 may be capable of being independently switched ON and OFF, similar to as explained with reference to switching DOEs 204 ON and OFF in the embodiment of Fig. 15. The DOEs 204 may be switched ON and OFF to selectively route light to the primary waveguides 202 based on the respective phase maps.

[0095] As illustrated in Fig. 16, light rays outwardly emanate from two of the primary waveguides 202a, 202d. For sake of illustration, a first planar waveguide 202a produces a plane or flat wavefront (illustrated by flat lines 238 about rays 240, only one instance of each called out for sake of drawing clarity) at an infinite focal distance. In contrast, another one of the primary waveguides 202d produces a convex wavefront (illustrated by arc 242 about rays 244, only one instance of each called out for sake of drawing clarity) at a defined focal distance less than infinite (e.g., 1 meter). As illustrated in Fig. 17, the primary waveguides 202 may laterally shift the appearance and/or optical viewing distances—i.e., different focus distances of a virtual object 246a-246c with respect to an exit pupil 248.

[0096] Referring back to Figs. 11-13, the projection subsystem 108 includes one or more light sources 250 that produces the light (e.g., emits light of different colors in defined patterns), a scanning device 252 that scans the light in a predetermined scan pattern (e.g., such as those described above with respect to Figs. 5-9) in response to

WO 2017/062667

PCT/US2016/055823

control signals, and an optical coupling subsystem 254 that couples the light from the scanning device 252 into the display screen 110.

[0097] The light source(s) 250 may take any of a large variety of forms, for instance, a set of RGB lasers (e.g., laser diodes capable of outputting red, green, and blue light) operable to respectively produce red, green, and blue coherent collimated light according to defined pixel patterns specified in respective frames of pixel information or data. Laser light provides high color saturation and is highly energy efficient.

[0098] The scanning device 252 comprises one or more optical fibers 256 (e.g., single mode optical fiber), each of which has a proximal end 256a into which light is received from the light source(s) 250 and a distal end 256b from which light is provided to the partially transparent display screen 110. The scanning device 252 further comprises a mechanical drive assembly 258 to which the optical fiber 256 is mounted. The drive assembly 258 is configured for displacing the distal end 256b of the optical fiber 256 about a fulcrum 260 in accordance with a scan pattern, such that the outputted light diverges from a longitudinal axis 262 coincident with the fulcrum 260. It should be appreciated that although the display subsystem 104 has been described as being implemented with a scanning fiber technology, it should be appreciated that the display subsystem 104 may be based on any display technology, e.g., liquid crystal displays (LCD), digital light processing (DLP) displays, etc.

[0099] The drive assembly 208 comprises a piezoelectric element 264 to which the optical fiber 256 is mounted, and drive electronics 266 configured for conveying electrical signals to the piezoelectric element 264, thereby causing the distal end 256b of the optical fiber 256 to vibrate in accordance with the scan pattern. Thus, operation

of the light source(s) 250 and drive electronics 266 are coordinated in a manner that generates image data that is encoded in the form of light that is spatially and/or temporally varying.

[00100] In the illustrated embodiment, the piezoelectric element 264 takes the form of a hollow tube, in which case, the distal end 256b of the optical fiber 256 is threaded or received through the piezoelectric tube 264. The distal end 256b of the optical fiber 256 protrudes from the piezoelectric tube 264 as a fixed-free flexible cantilever 268 (shown in Figs. 18a and 18b). The piezoelectric tube 264 is associated with four quadrant electrodes (not illustrated). The electrodes may, for example, be plated on the outside, outer surface or outer periphery or diameter of the piezoelectric tube 264. A core electrode (not illustrated) is also located in a core, center, inner periphery or inner diameter of the tube 264.

[00101] The drive electronics 266 are electrical coupled via wires 270 to drive opposing pairs of electrodes (not shown) to bend the piezoelectric tube 264 in two axes independently. The protruding distal tip of the optical fiber 256 has mechanical modes of resonance. The frequencies of resonance depend upon a diameter, length, and material properties of the optical fiber 256. By vibrating the piezoelectric tube 264 near a first mode of mechanical resonance of the fiber cantilever 268, the fiber cantilever 268 is caused to vibrate, and can sweep through large deflections about the fulcrum 260. By stimulating resonant vibration in two axes, the tip of the fiber cantilever 268 is scanned biaxially in an area filling 2D scan. By modulating an intensity of the light source(s) 250 in synchrony with the scan of the fiber cantilever 268, light emerging from the fiber cantilever 268 forms an image.

[00102] As briefly discussed above, the optical coupling subsystem 254 optically couples light from the scanning device 252 to the waveguide apparatus 102. The optical coupling subsystem 254 includes an optical waveguide input apparatus 272, for instance, one or more reflective surfaces, diffraction gratings, mirrors, dichroic mirrors, or prisms to optically couple light into the end of the waveguide apparatus 102. The optical coupling subsystem 254 additionally or alternatively includes a collimation element 274 that collimates light from the optical fiber 256.

[00103] As briefly discussed above, the light emitted from the scanning device 252 initially diverges from the longitudinal axis 262 as the distal end 256b of the optical fiber 256 is vibrated about the fulcrum 260. At each position of the optical fiber 256, the light initially fans out from the distal end 256b, and is collimated to a narrow light ray by the collimation element 274. Without modification, a relatively large optical waveguide input apparatus 272 will be needed to accommodate the relatively large deflections in the distal end 256b of the optical fiber 256.

[00104] To this end, the optical coupling subsystem 254 comprises an optical modulation apparatus 276 configured for converging the light from the collimation element 274 towards the longitudinal axis 262, and in the illustrated embodiment, converging the light on a focal point 278 in the center of the optical waveguide input apparatus 272, as shown in Fig. 18a. Notably, focusing the light at the center of the optical waveguide input apparatus 272 allows the size of the optical waveguide input apparatus 272 to be minimized. That is, focusing the light at the center of the optical waveguide input apparatus 272 minimizes the worst-case divergent span of the swept light path at the edges of the optical waveguide input apparatus 272. For example, if

the light is focused on the front edge of the optical waveguide input apparatus 272, as illustrated in Fig. 18b, the optical waveguide input apparatus 272 must be made larger to accommodate the larger divergent span of the swept light path at the rear edge of the optical waveguide input apparatus 272.

[00105] Referring now to Fig. 19, the interaction between the input optical modulation apparatus 276 and one embodiment of an optical waveguide input apparatus 272 will be described. In this case, the optical waveguide input apparatus 272 takes the form of a distribution waveguide apparatus 222 with associated distribution waveguide 224 and DOEs 226a-226e described with respect to Figs. 13a-13c. As shown in Fig. 19, the optical modulation apparatus 276 converges the light from the collimation element 274 on a focal point 278 located at the DOE 226c, thereby minimizing the size of the DOEs 226. As a result, the overall width of the distribution waveguide 224 is minimized. The light is then selectively conveyed down one or more of the primary waveguides 202a-202e.

[00106] Referring now to Fig. 20, the DOEs 226 can alternatively be incorporated directly into the primary waveguide apparatus 200. In this case, the DOEs 226 respectively extend parallel along the primary planar waveguides 202a-202e of the waveguide apparatus 200, such that the DOEs 226 respectively direct the light from the optical modulation apparatus 276 down the primary waveguides 202. As shown in Fig. 20, the optical modulation apparatus 276 converges the light from the collimation element 274 on a focal point 278 located the DOE 226c, thereby minimizing the size of the DOEs 226. Since the focal point 278 is at the center of the input optical modulation apparatus 276, the lengths of the DOEs 226a and 226e can be made equal in order to

minimize the worst-case DOE 226. As a result, the overall size of the waveguide apparatus 200 is minimized.

[00107] In one embodiment, the optical modulation apparatus 276 comprises one or more diffraction gratings, each of which can be characterized as an optical component with a periodic structure on the order of the light wavelength that splits and diffracts light into several beams travelling in different directions. The diffraction gratings can either be transmissive or reflective, and be composed of, e.g., surface nano-ridges, nano-patterns, slits, etc. that may be photolithographically printed on a substrate. In an alternative embodiment, the optical modulation apparatus 276 may comprise one or more lenses.

[00108] In the illustrated embodiment, the optical modulation apparatus 276 has a diffraction pattern that matches the geometry of the scan pattern, such that the collimation of the light is preserved at a target resolution. For example, if a spiral scan pattern is used, the diffraction pattern may have a pattern of diffraction elements 280, as illustrated in Fig. 21. If a single diffraction grating is used, each diffraction element may diffract light rays 282a and 282b inwardly in two dimensions (e.g., in the case of Fig. 22a, in the x- and y- directions, such that each diffraction element 280a and 280b (only two shown) diffracts the light towards a single focal point 278 at the origin of the x-y coordinate system). Alternatively, two orthogonal diffraction gratings 276a and 276b in series can be used, such that the diffraction elements 278a and 278b of one diffraction grating 276a diffracts the respective light rays 280a and 280b along one axis of the x-y coordinate system (e.g., in the case of Fig. 22b, the x-direction), and the diffraction elements of the other diffraction grating 276b diffracts the light rays 280a and 280b

along the other axis of the x-y coordinate system (e.g., in the case of Fig. 20b, the y-direction).

[00109] Although particular embodiments of the invention have been shown and described, it will be understood that it is not intended to limit the invention to the embodiments, and it will be obvious to those skilled in the art that various changes and modifications may be made without departing from the spirit and scope of the invention. Thus, the invention is intended to cover alternatives, modifications, and equivalents, which may be included within the spirit and scope of the invention as defined by the claims.

We claim:

1. A display subsystem for a virtual image generation system for use by an end user, comprising:

a planar waveguide apparatus;

an optical fiber;

at least one light source configured for emitting light from a distal end of the optical fiber;

a mechanical drive assembly to which the optical fiber is mounted as a fixed-free flexible cantilever, the drive assembly configured for displacing the distal end of the optical fiber about a fulcrum in accordance with a scan pattern, such that the emitted light initially diverges from a longitudinal axis coincident with the fulcrum from each of a plurality of off-axis scanning positions of the optical fiber;

an optical modulation apparatus configured for converging the emitted light from the optical fiber at each of the off-axis scanning positions towards the longitudinal axis; and

an optical waveguide input apparatus configured for directing the light from the optical modulation apparatus down the planar waveguide apparatus, such that the planar waveguide apparatus displays one or more image frames to the end user.

2. The display subsystem of claim 1, wherein the optical modulation apparatus is configured for converging the light from the optical fiber on a focal point on the longitudinal axis.

3. The display subsystem of claim 2, wherein the focal point is located within the optical waveguide input apparatus.

4. The display subsystem of claim 1, further comprising a collimation element configured for collimating light from the optical fiber.

5. The display subsystem of claim 1, wherein the optical modulation apparatus comprises at least one diffraction grating.

6. The display subsystem of claim 5, wherein each of the at least one diffraction grating has a diffraction pattern that matches a geometry of the scan pattern.

7. The display subsystem of claim 6, wherein the scan pattern is a spiral scan pattern, and the diffraction pattern is a spiral diffraction pattern.

8. The display subsystem of claim 1, wherein the optical modulation apparatus comprises two orthogonal diffraction gratings in series, such that one of the diffraction gratings diffracts light along a first axis, and another one of the diffraction gratings diffracts light along a second axis orthogonal to the first axis.

9. The display subsystem of claim 1, wherein the mechanical drive assembly comprises a piezoelectric element to which the optical fiber is mounted, and drive electronics configured for conveying electrical signals to the piezoelectric element, thereby causing the optical fiber to vibrate in accordance with the scan pattern.

10. The display subsystem of claim 1, wherein the planar waveguide apparatus comprises a plurality of planar waveguides configured for respectively displaying the one or more image frames at different focal points to the end user, and the optical waveguide input apparatus is configured for directing the light from the optical modulation apparatus down the plurality of planar waveguides.

11. The display subsystem of claim 10, wherein the optical waveguide input apparatus comprises a plurality of diffractive optical elements respectively extending parallel along the planar waveguides, the plurality of diffractive optical elements respectively directing the light from the optical modulation apparatus down the planar waveguides.

12. The display subsystem of claim 10, wherein the optical waveguide input apparatus comprises a distribution waveguide extending perpendicularly to the planar waveguides, the distribution waveguide comprising a plurality of diffractive optical elements

that respectively direct the light from the optical modulation apparatus down the planar waveguides.

13. The display subsystem of claim 1, wherein the planar waveguide apparatus is configured for being positioned in front of the end user's eyes.

14. The display subsystem of claim 1, wherein the planar waveguide apparatus has a partially transparent display surface configured for being positioned in a field of view between the end user's eyes and an ambient environment.

15. The display subsystem of claim 1, further comprising a frame structure configured for being worn by the end user, the frame structure carrying the planar waveguide apparatus.

16. A virtual image generation system for use by an end user, comprising:
memory storing a three-dimensional scene;
a control subsystem configured for rendering a plurality of synthetic image frames of the three-dimensional scene; and

the display subsystem of claim 1, the display subsystem configured for sequentially displaying the plurality of image frames to the end user.

17. The virtual image generation system of claim 16, wherein the control subsystem comprises a graphics processing unit (GPU).

18. The virtual image generation system of claim 16, wherein one of the off-axis scanning positions is an extreme scanning position of the optical fiber.

19. The virtual image generation system of claim 16, wherein the optical modulation apparatus is configured for converging the light from all off-axis scanning positions of the optical fiber towards the longitudinal axis.

20. A display subsystem for a virtual image generation system for use by an end user, comprising:

a planar waveguide apparatus;

an optical fiber;

at least one light source configured for emitting light from a distal end of the optical fiber;

a mechanical drive assembly to which the optical fiber is mounted as a fixed-free flexible cantilever, the drive assembly configured for displacing the distal end of the optical fiber about a fulcrum in accordance with a scan pattern, such that the emitted light diverges from a longitudinal axis coincident with the fulcrum;

an optical modulation apparatus configured for converging the light from the optical fiber towards the longitudinal axis; and

an optical waveguide input apparatus configured for directing the light from the optical modulation apparatus down the planar waveguide apparatus, such that the planar waveguide apparatus displays one or more image frames to the end user,

wherein the optical modulation apparatus comprises two orthogonal diffraction gratings in series, such that one of the diffraction gratings diffracts light along a first axis, and another one of the diffraction gratings diffracts light along a second axis orthogonal to the first axis.

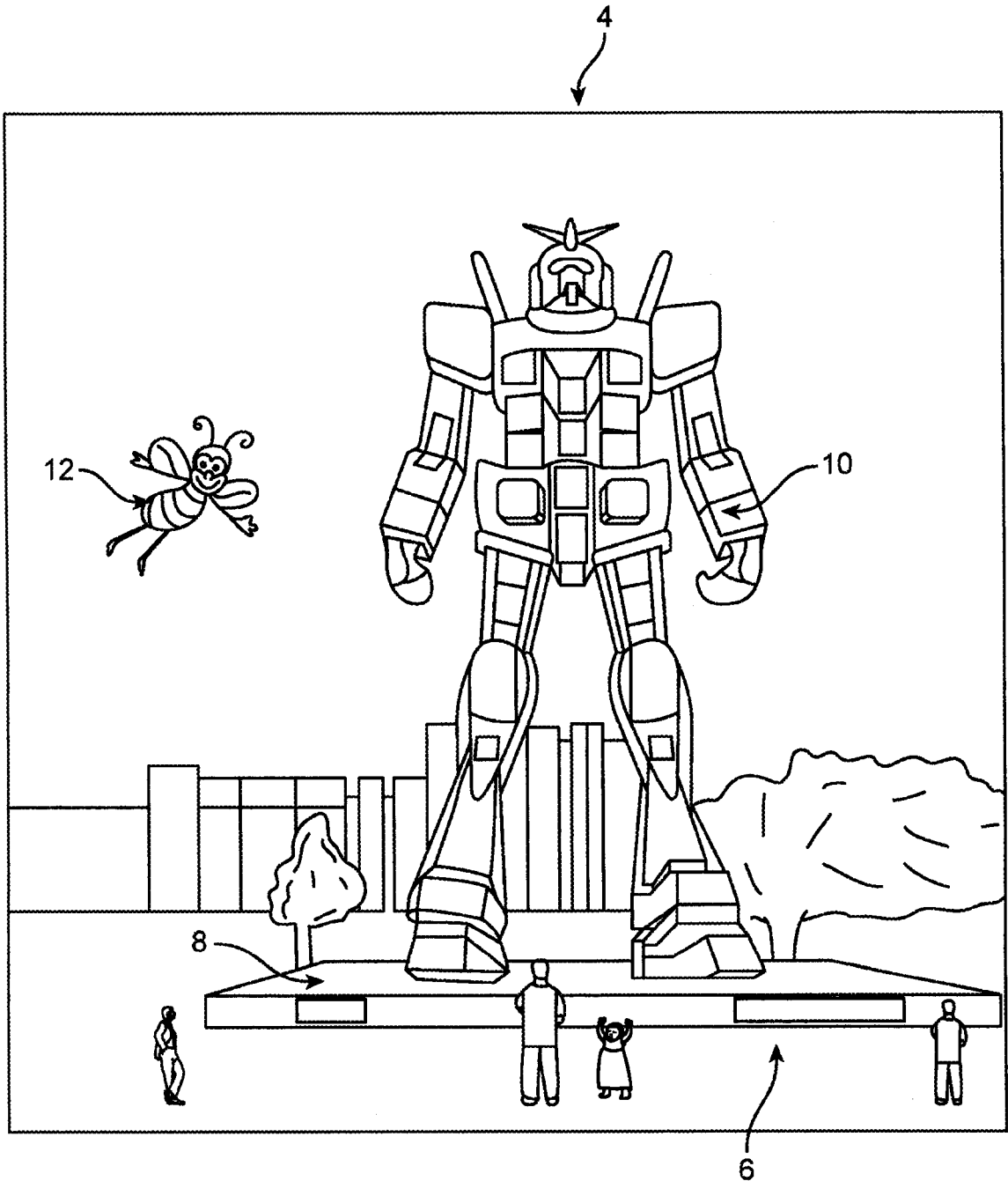

FIG. 1

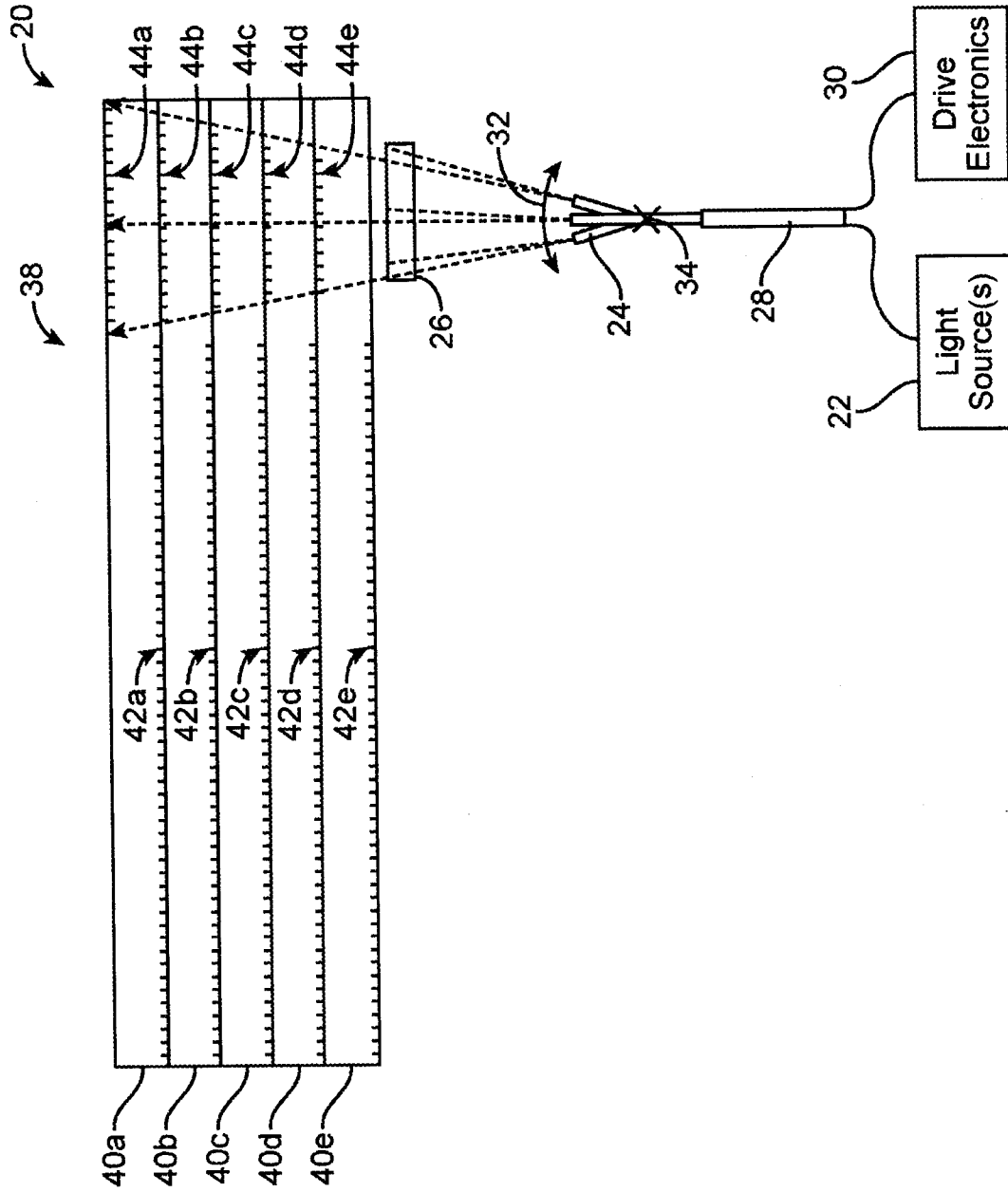

FIG. 2

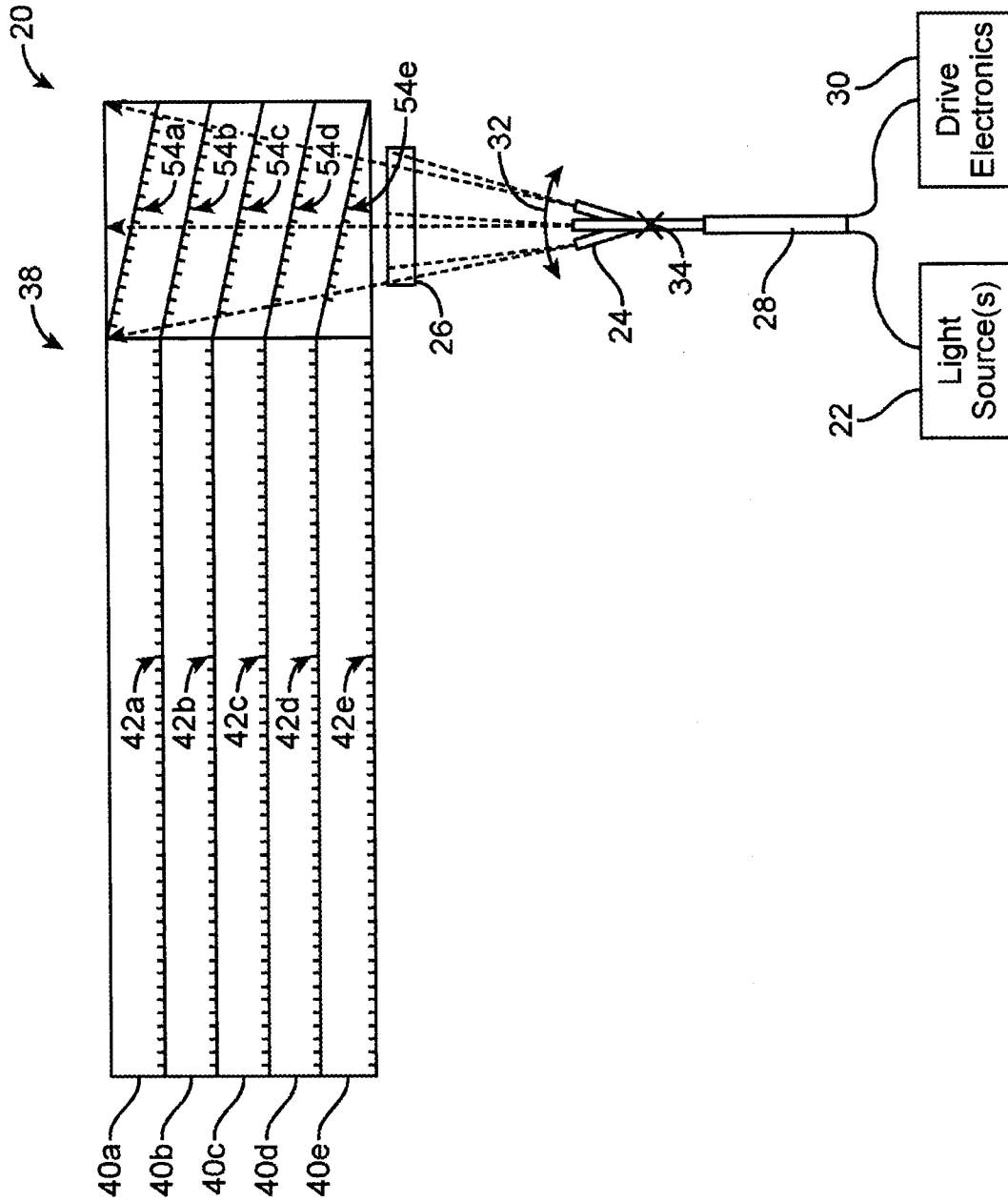

FIG. 3

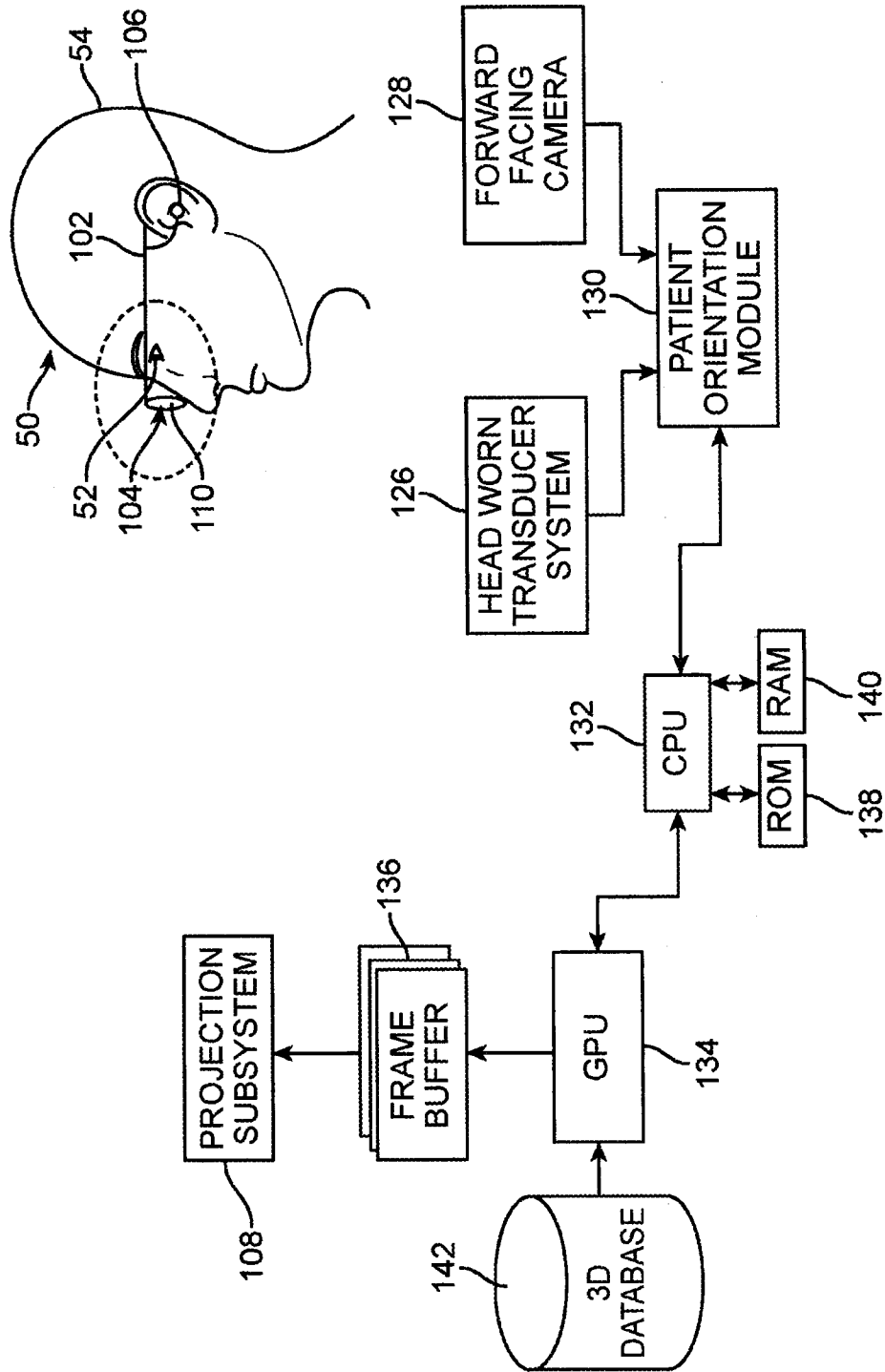

FIG. 4

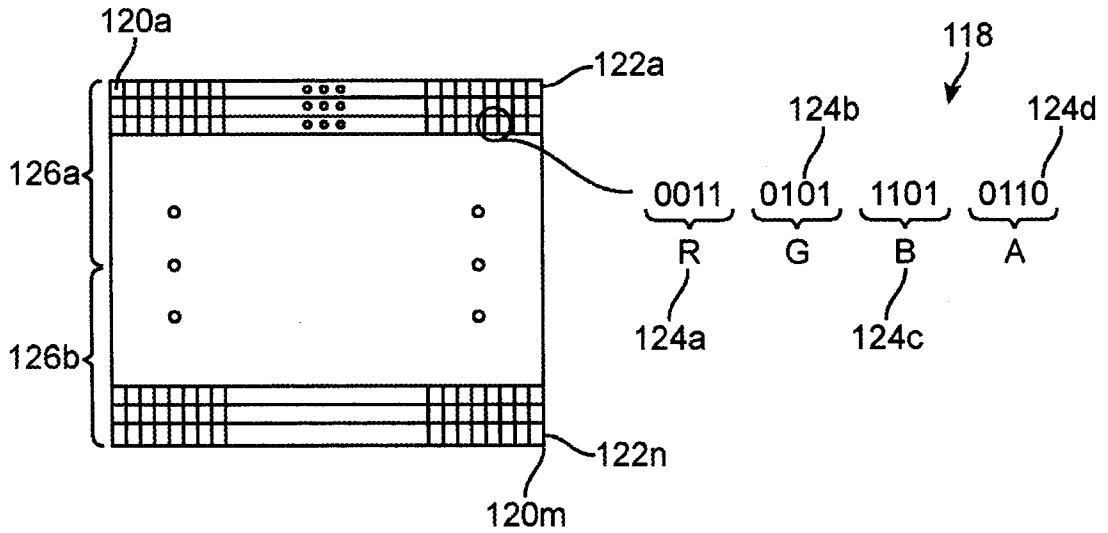

FIG. 5

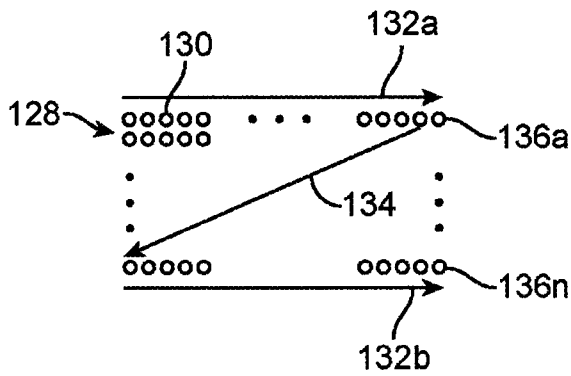

FIG. 6

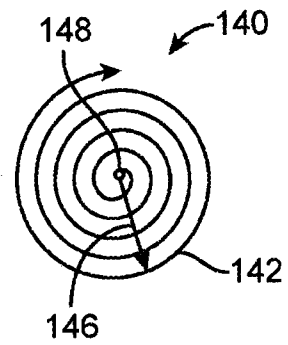

FIG. 7

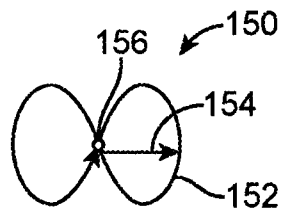

FIG. 8

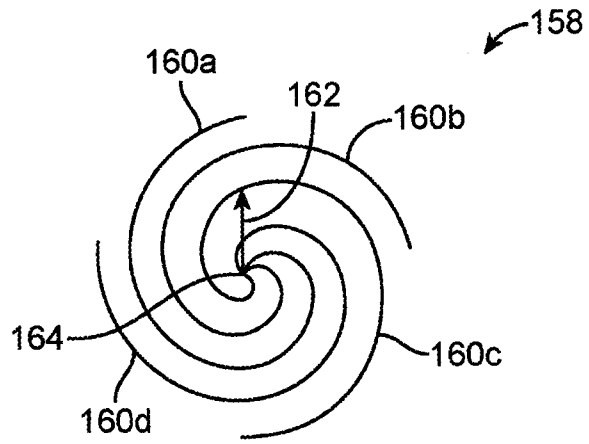

FIG. 9

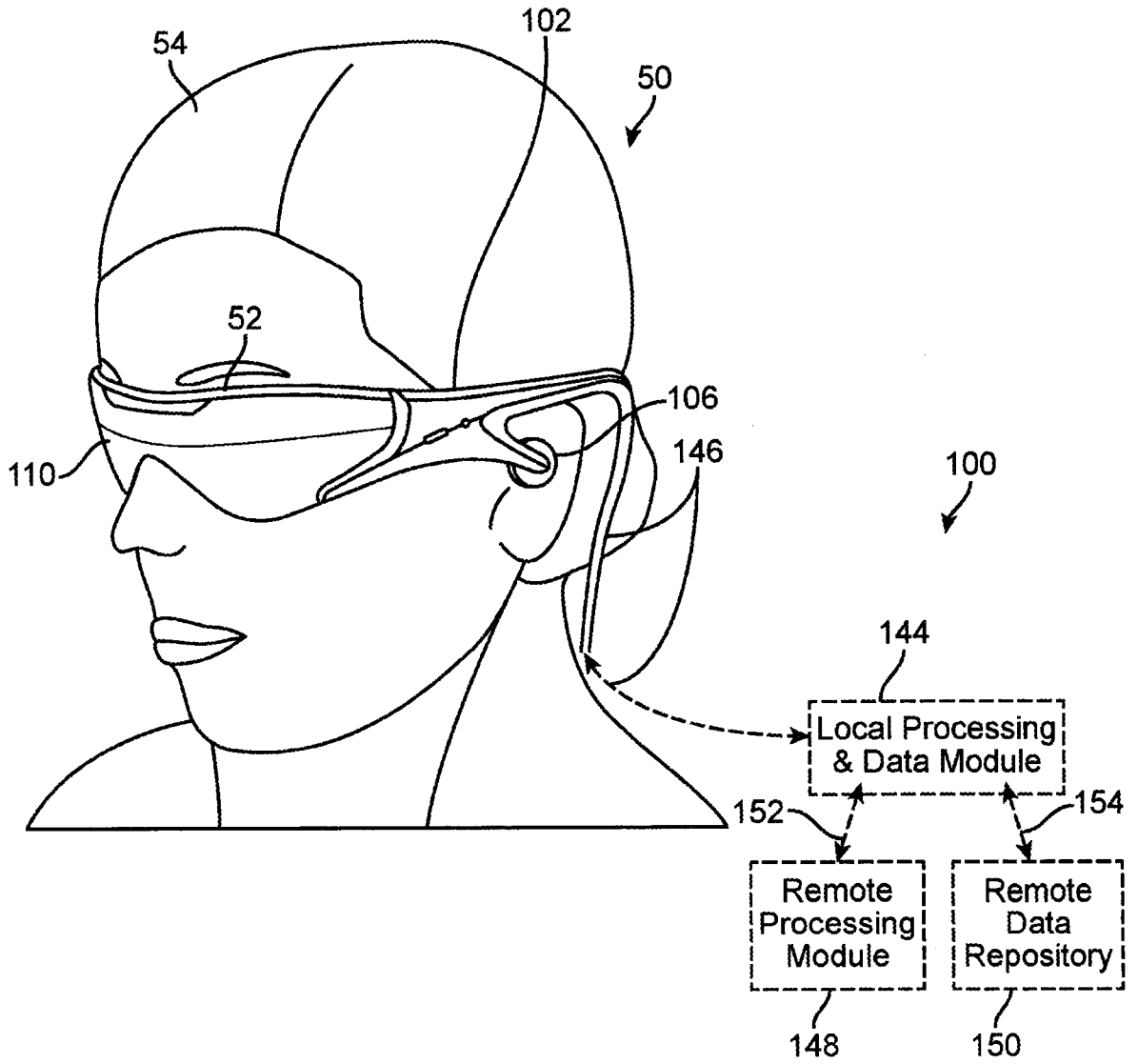

FIG. 10a

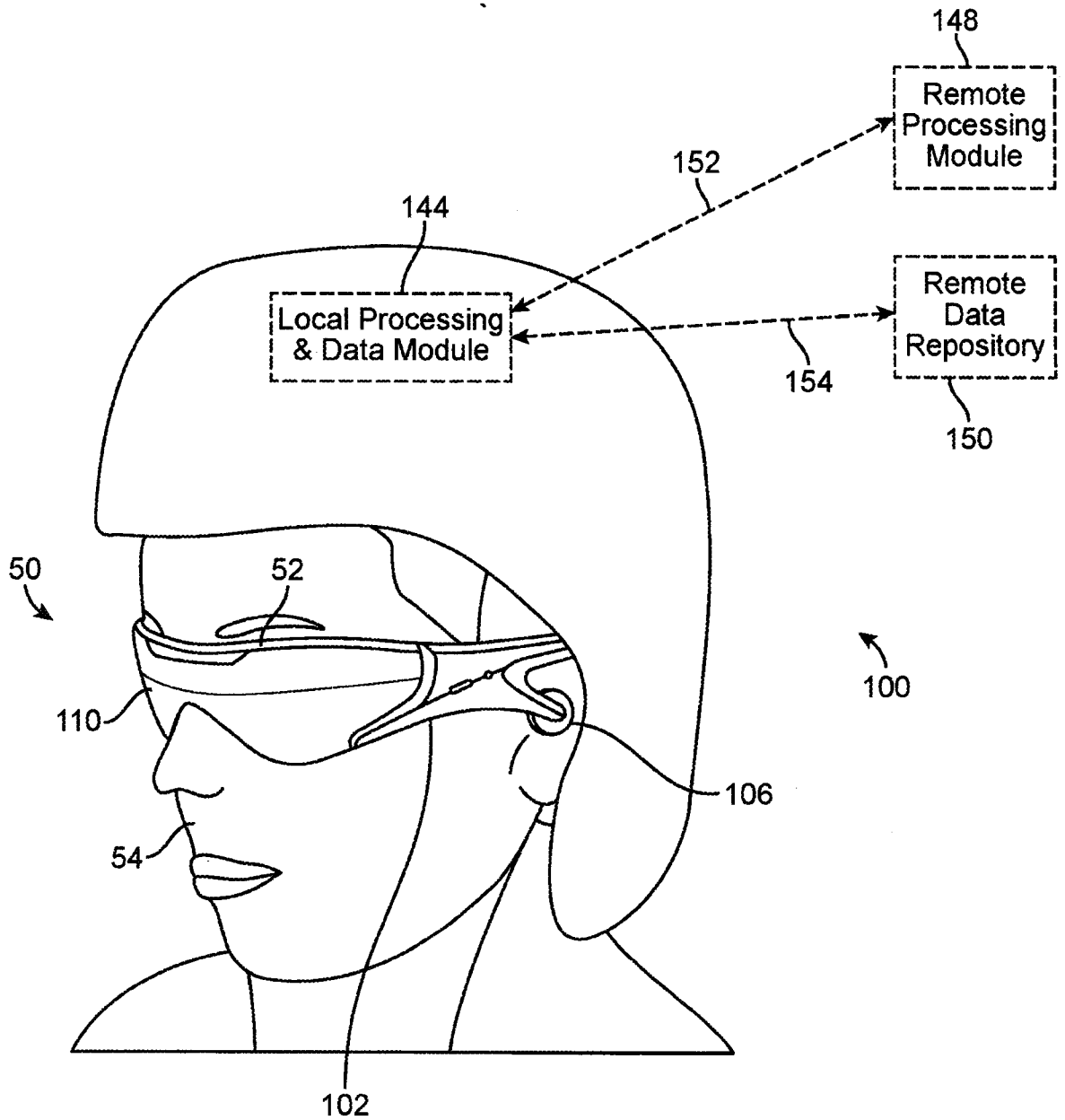

FIG. 10b

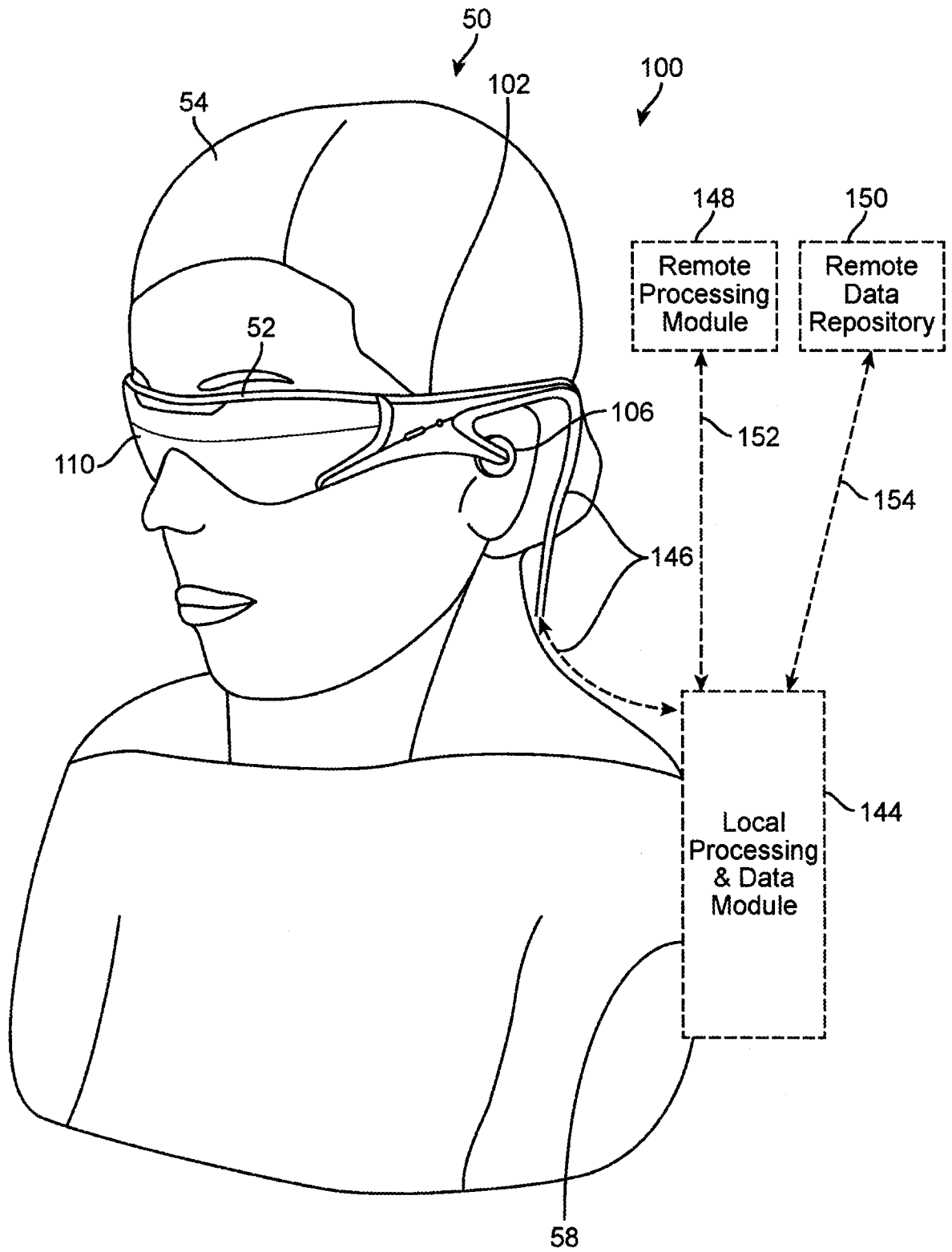

FIG. 10c

10 / 22

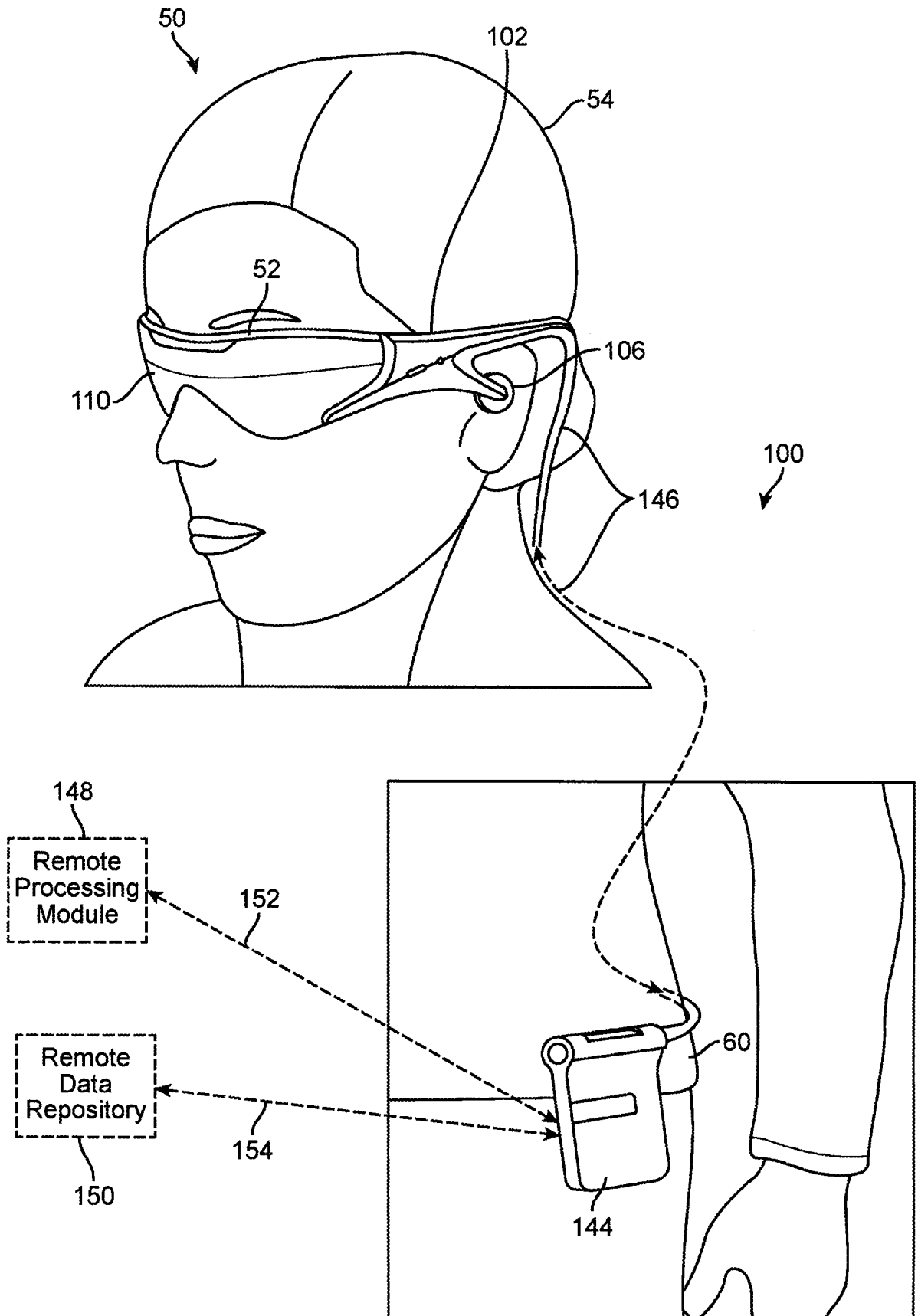

FIG. 10d

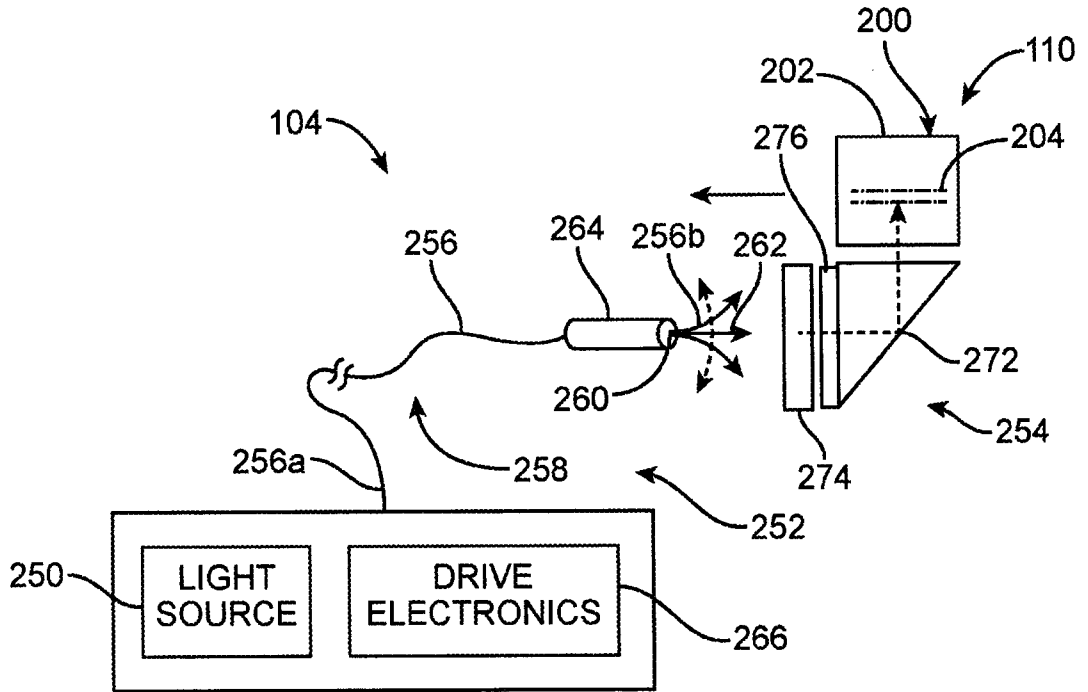

FIG. 11

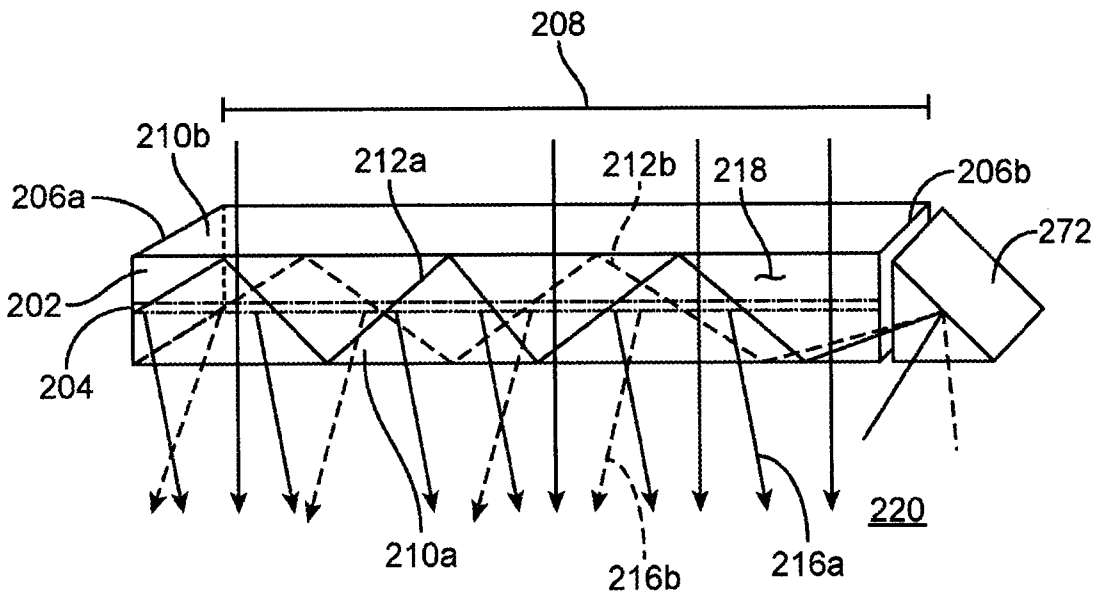

FIG. 12

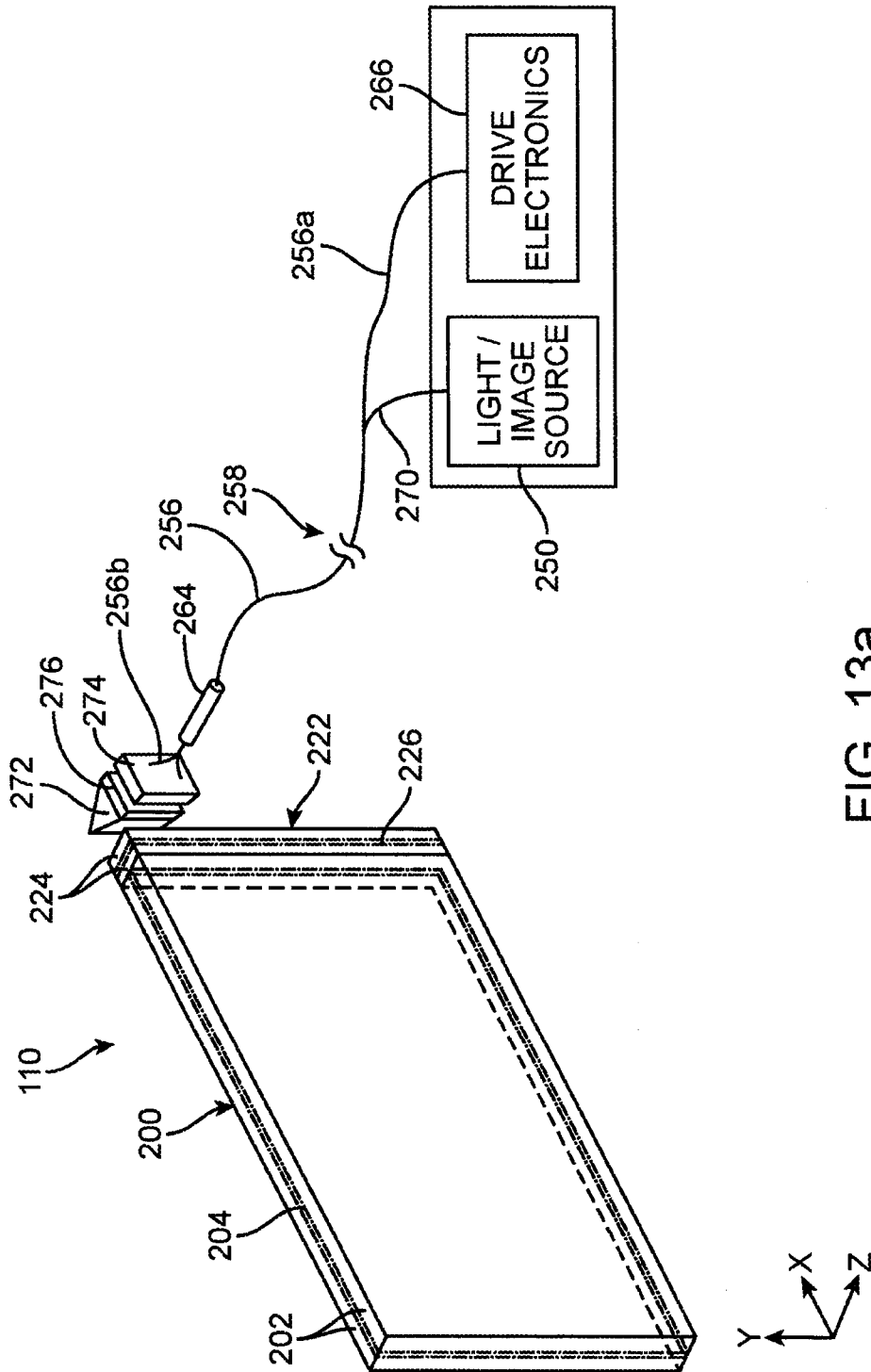

FIG. 13a

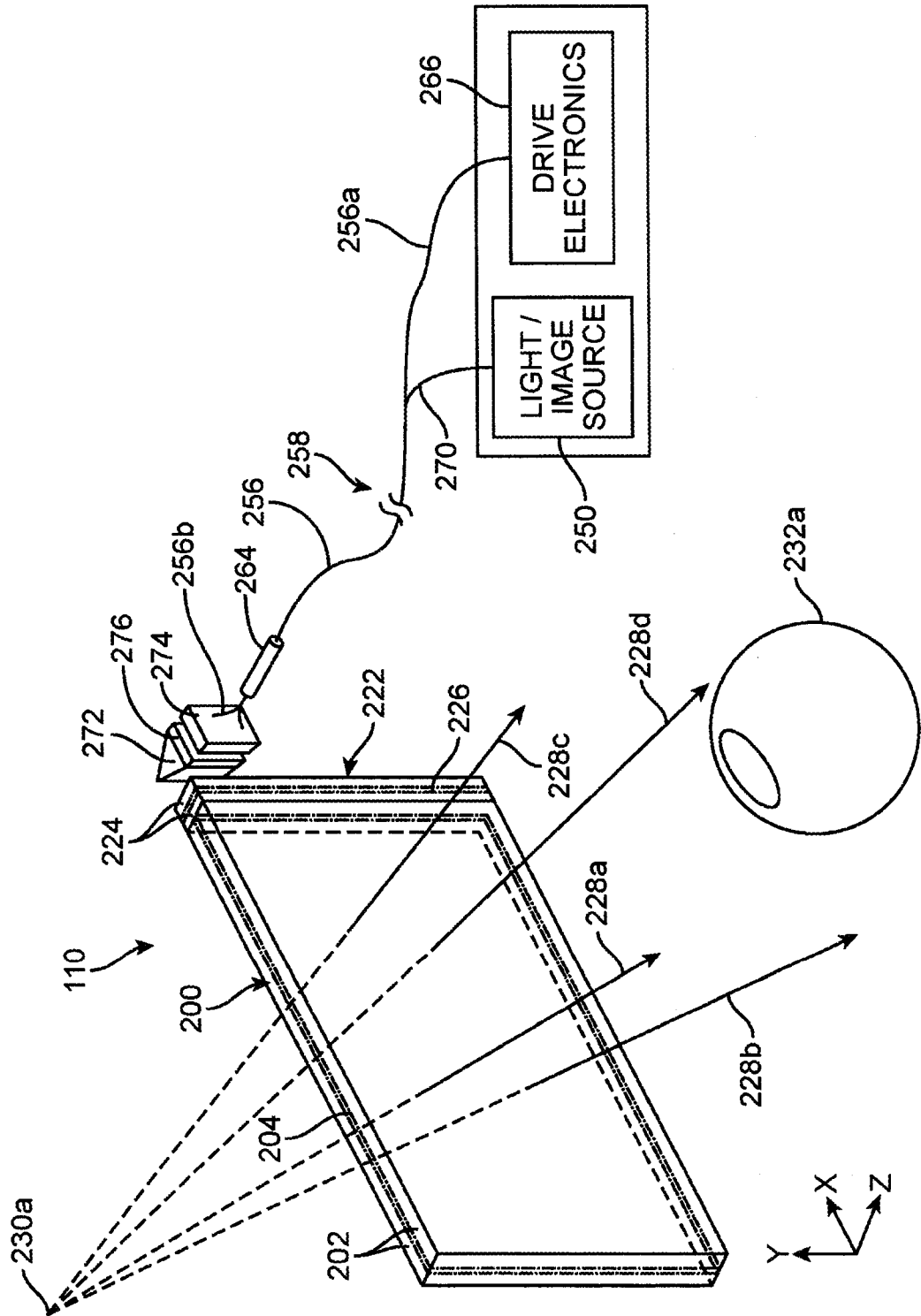

FIG. 13b

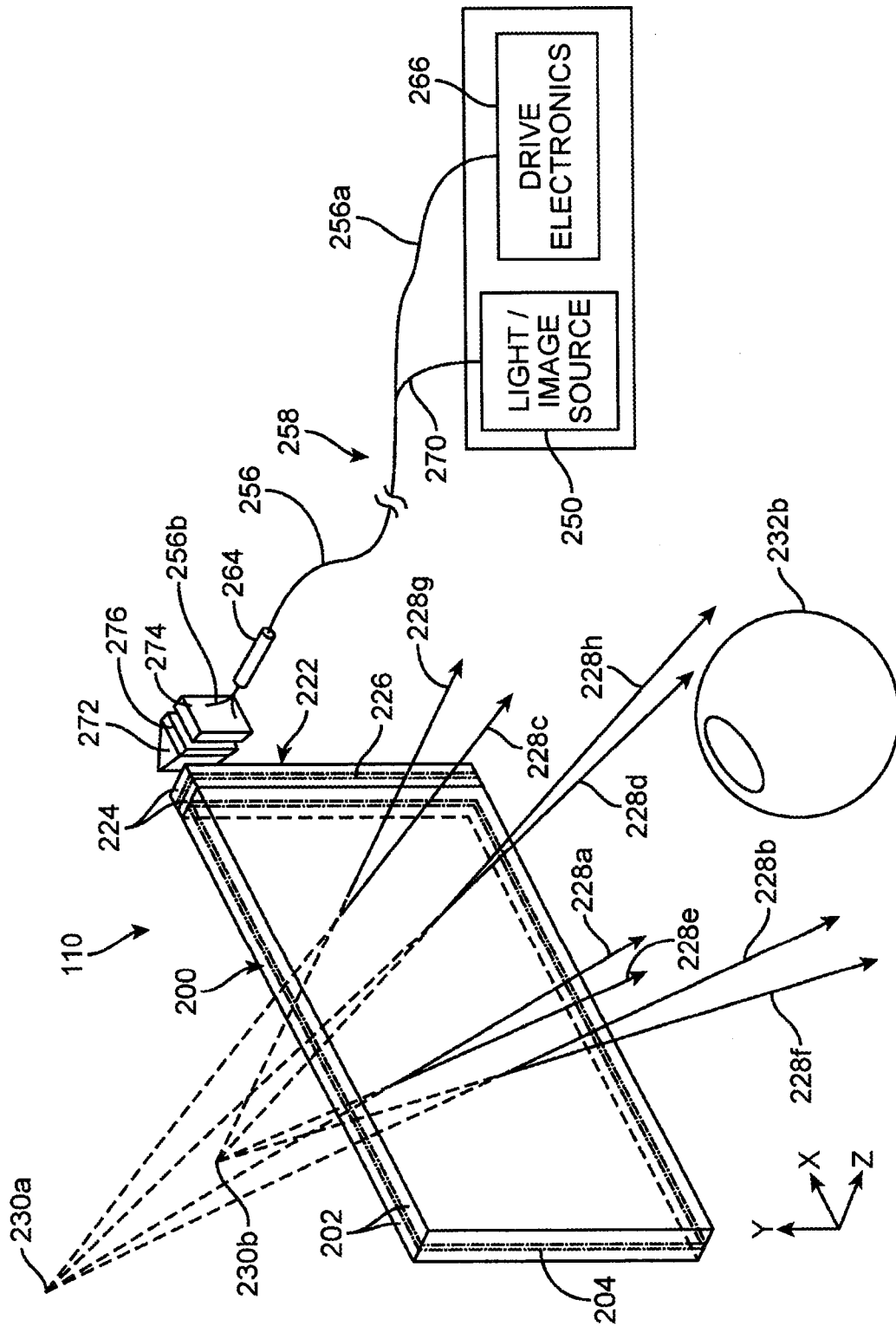

FIG. 13C

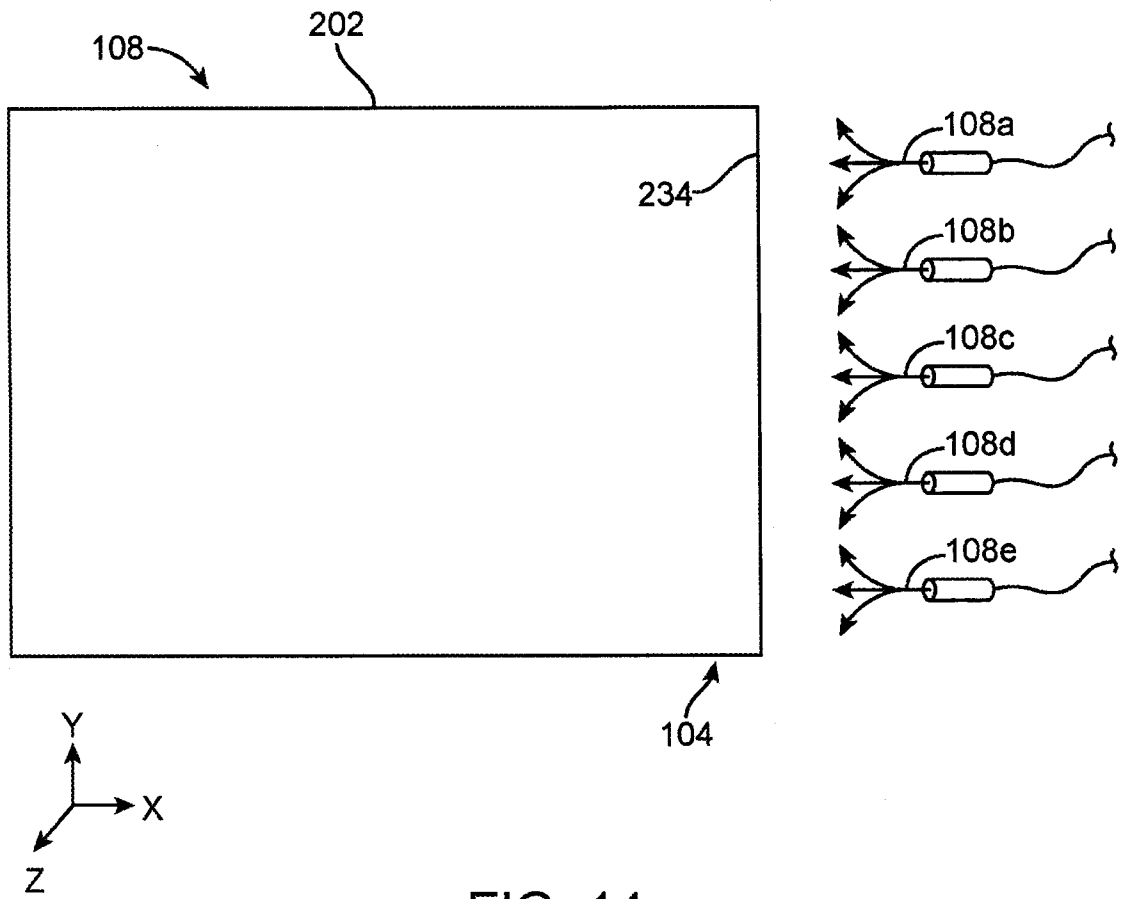

FIG. 14

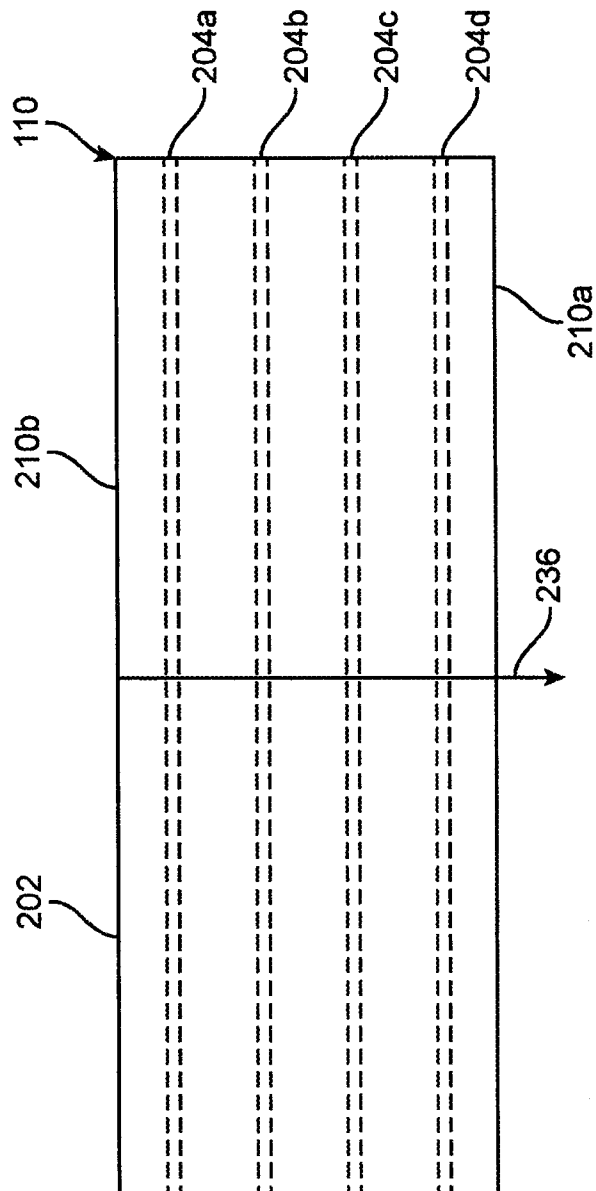

FIG. 15

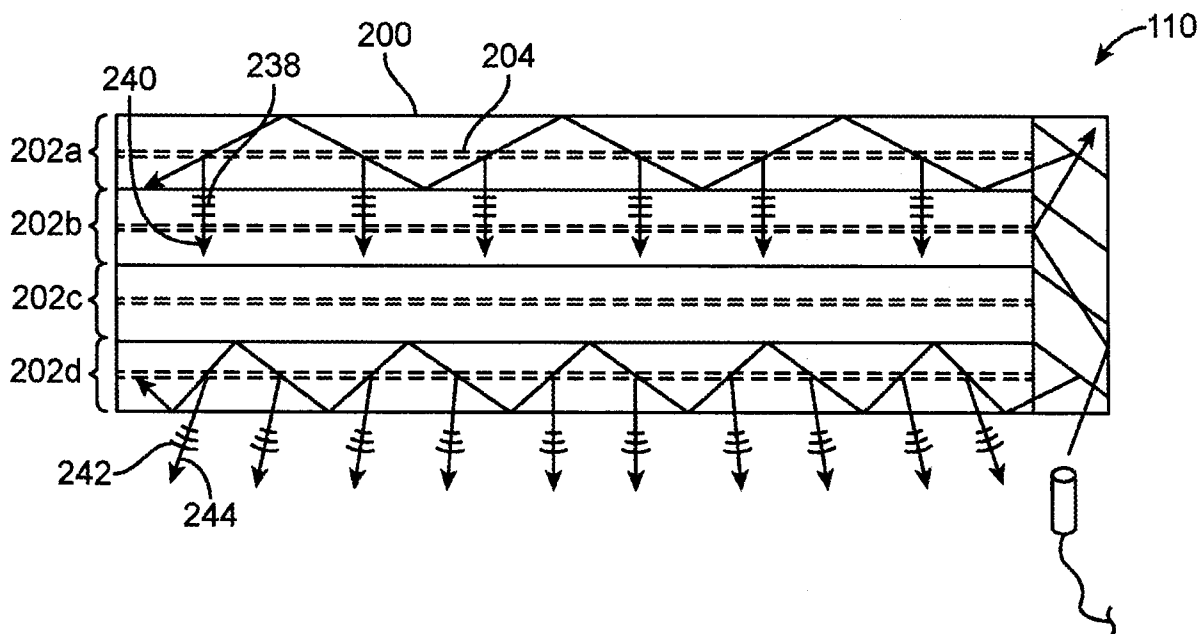

FIG. 16

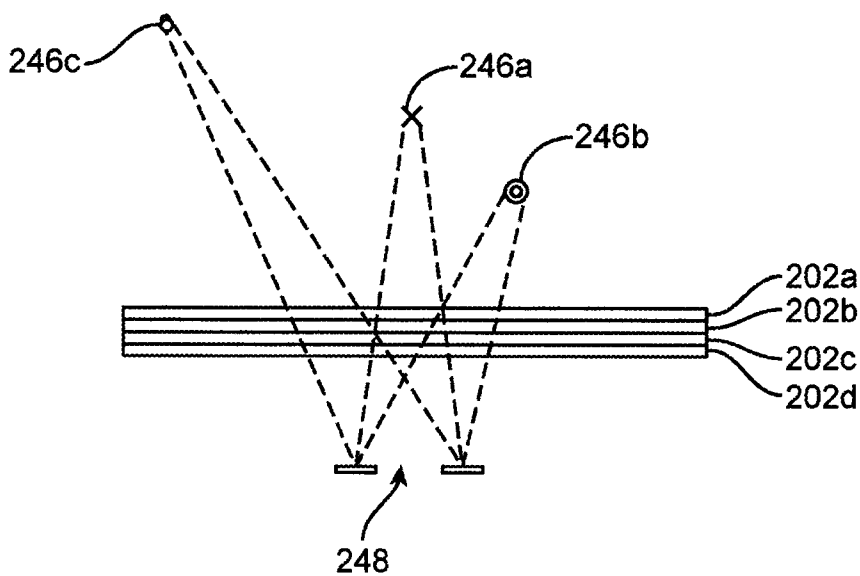

FIG. 17

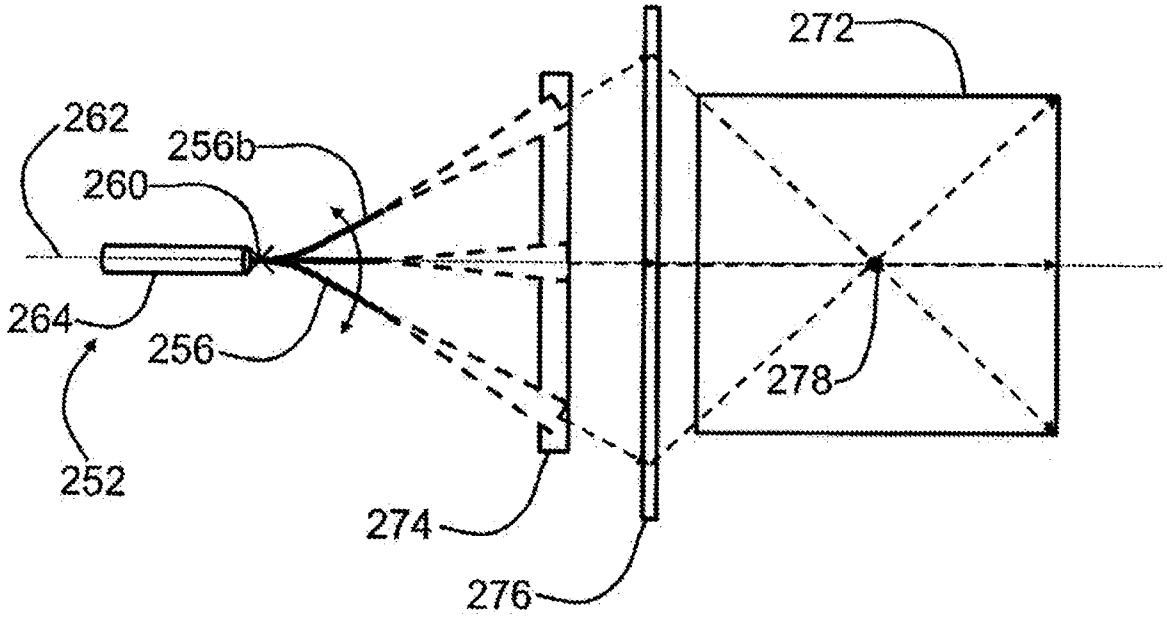

FIG. 18a

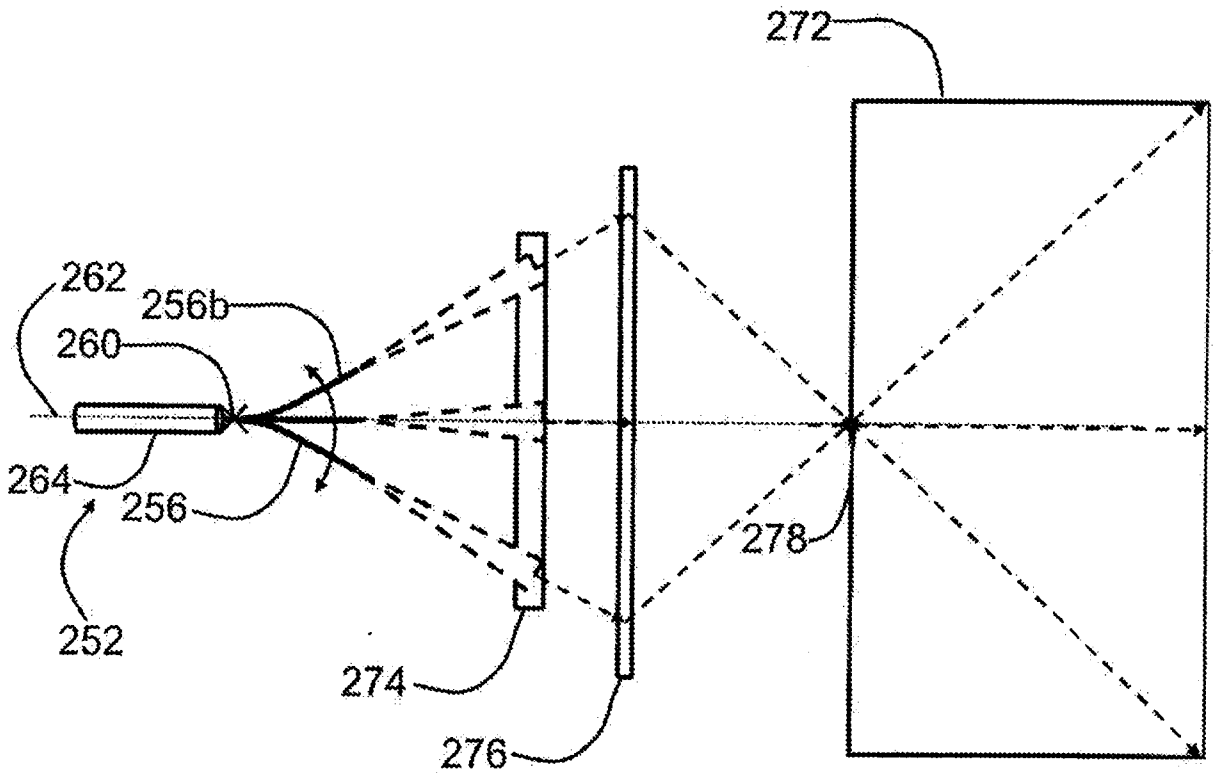

FIG. 18b

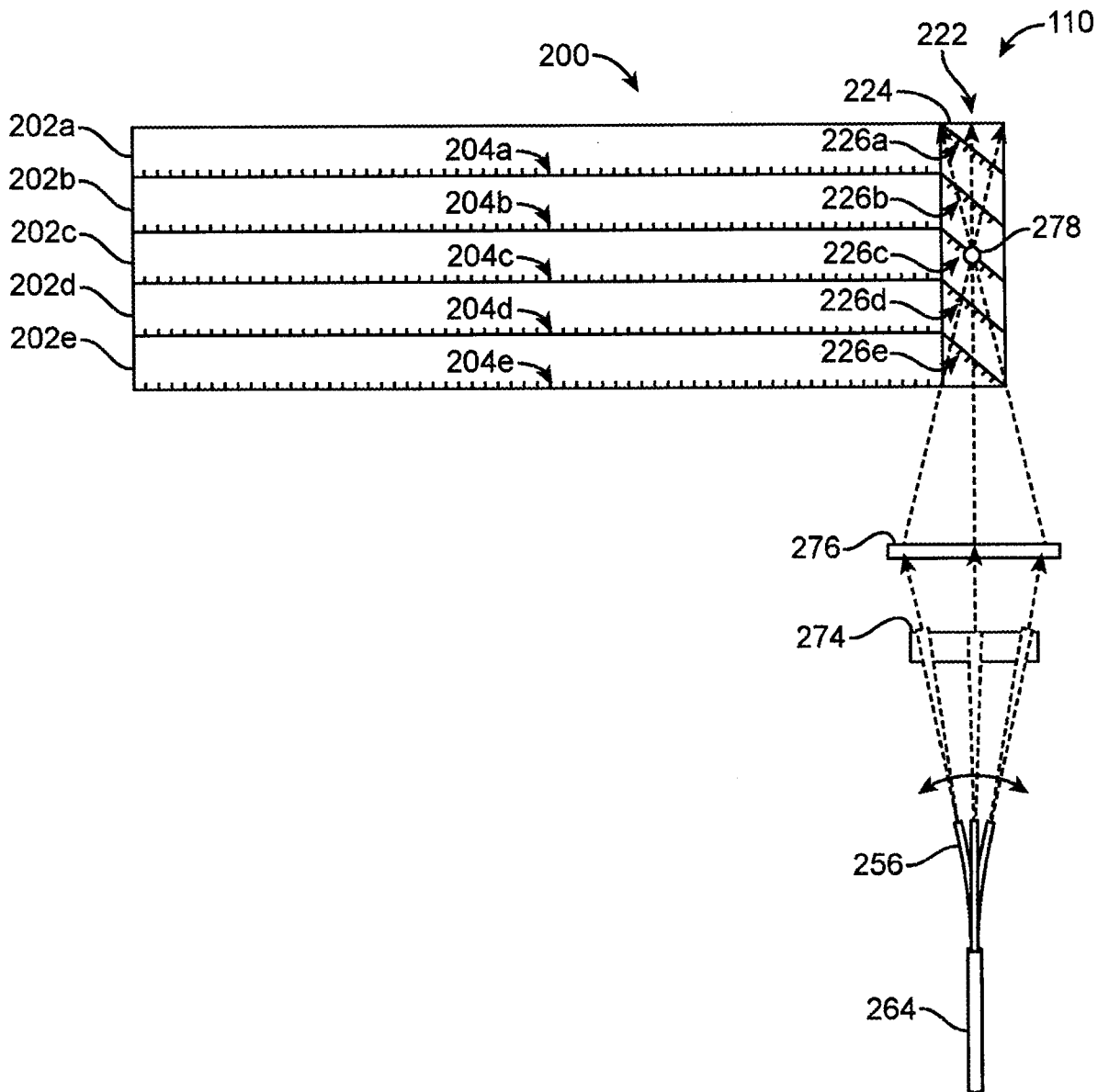

FIG. 19

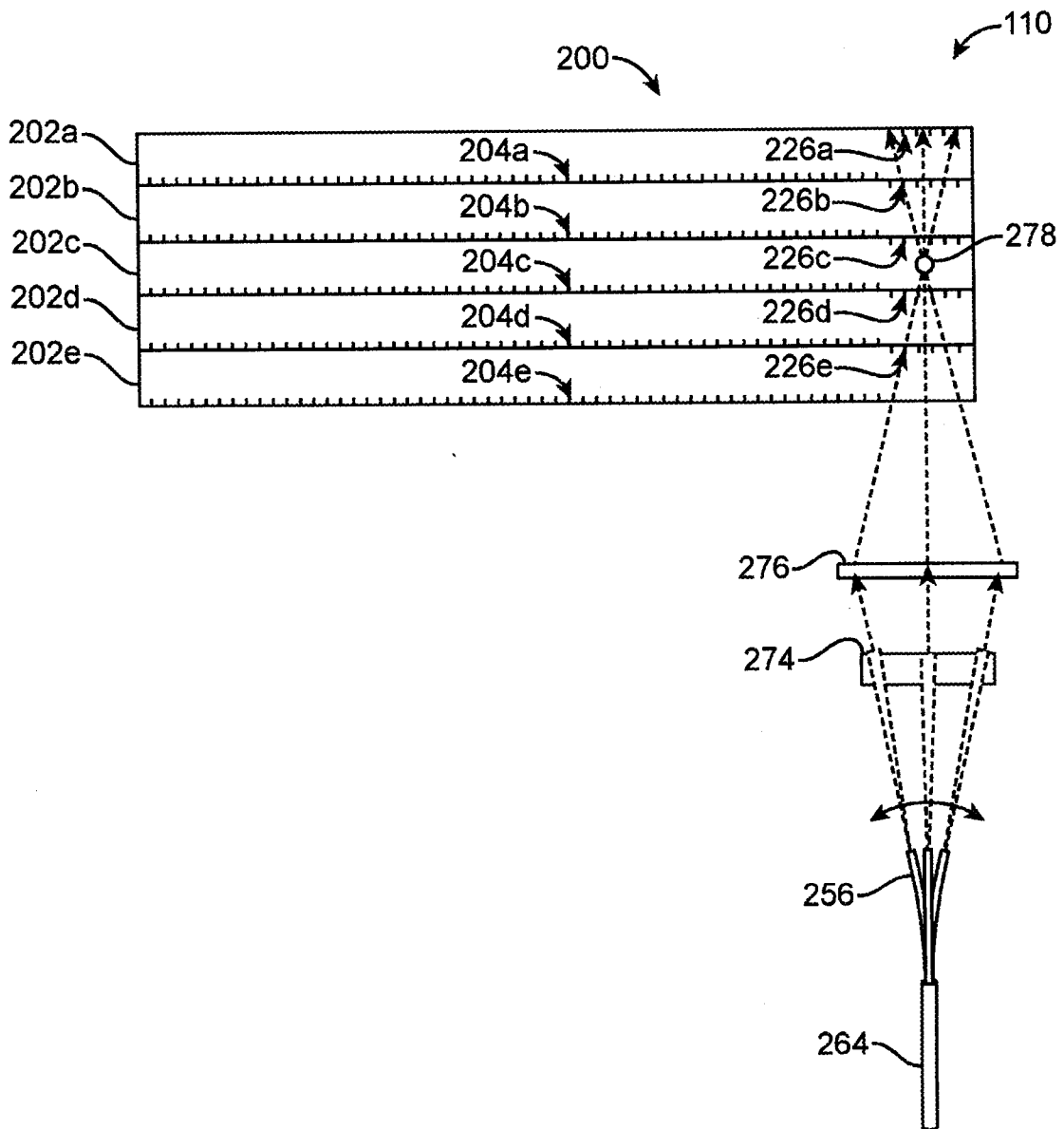

FIG. 20

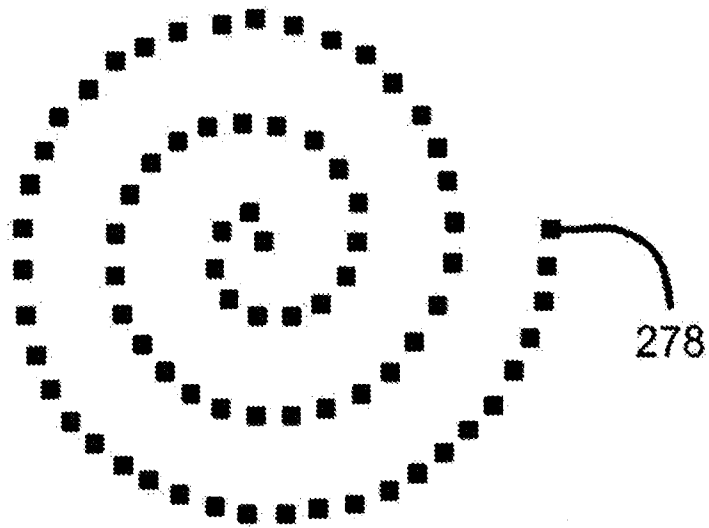

FIG. 21

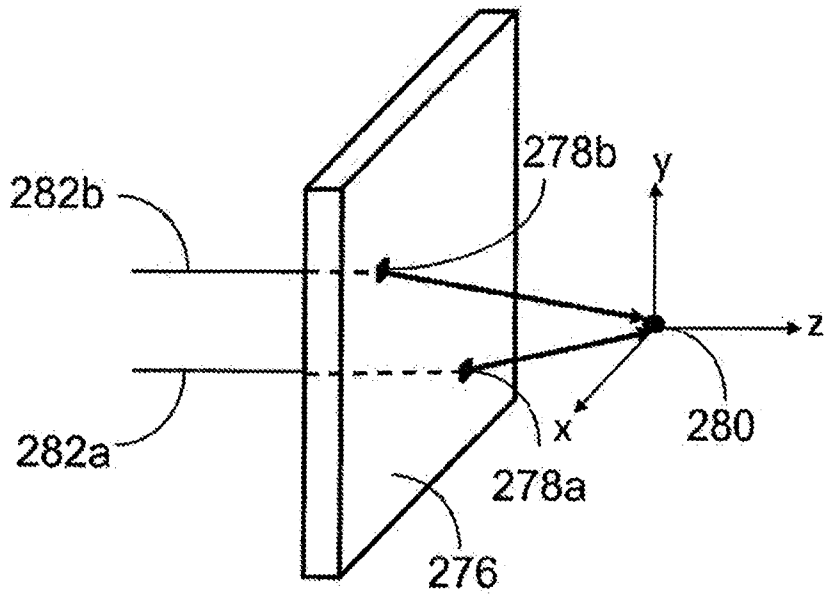

FIG. 22a

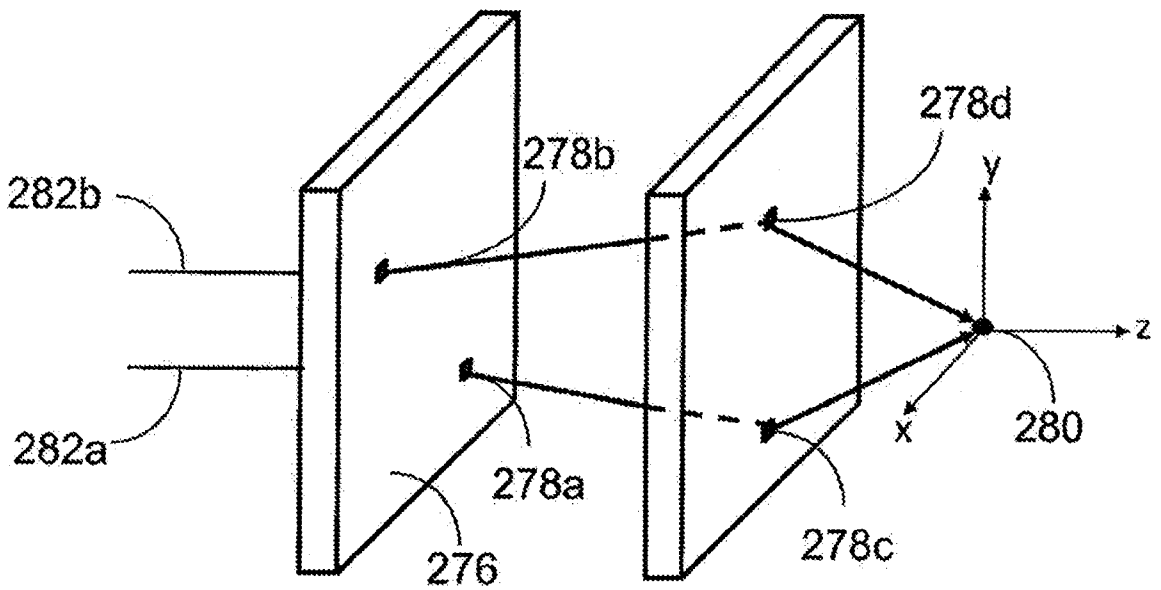

FIG. 22b

