

**EUROPEAN PATENT APPLICATION**

Application number: 85303399.1

Int. Cl.4: **A 47 G 7/06**

Date of filing: 14.05.85

Priority: 15.05.84 IE 2662/83

Date of publication of application:  
04.12.85 Bulletin 85/49

Designated Contracting States:  
AT BE CH DE FR GB IT LI LU NL SE

Applicant: **Carroll, Francis Alfred**  
**Lock House**  
**Oldbrigde Drogheda County Meath(IE)**

Applicant: **Hamilton, Mervyn**  
**26, Coldcotes Avenue**  
**Harehills Leeds Yorkshire(GB)**

Inventor: **Carroll, Francis Alfred**  
**Lock House**  
**Oldbrigde Drogheda County Meath(IE)**

Inventor: **Hamilton, Mervyn**  
**26, Coldcotes Avenue**  
**Harehills Leeds Yorkshire(GB)**

Representative: **Adams, William Gordon et al,**  
**RAWORTH, MOSS & COOK 36 Sydenham Road**  
**Croydon Surrey CR0 2EF(GB)**

**Components for assembling a flower vase.**

A vase comprises a frame member (12) and an outer sleeve (14) of generally truncated pyramidal form. A polyethylene bag (13) is retained in position between the frame member (12) and the outer sleeve (14). The frame member (12) comprises a pair of blanks (16) secured together by a rivet (21). The outer sleeve (14) comprises a blank having four side walls (22) complementary with the frame member and is constructed using the adhesive backed flap (23). The frame member (12) and the outer sleeve (14) may be delivered to a user in a compact flat condition.

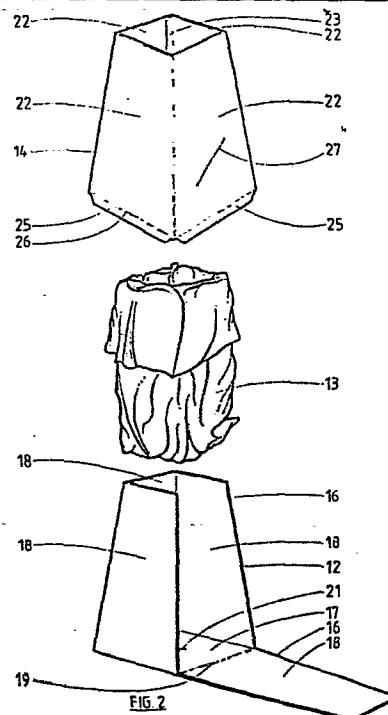

FIG. 2

EP 0 163 453 A1

COMPONENTS FOR ASSEMBLING A FLOWER VASE

The present invention relates to a vase for flowers and in particular to components for assembling such a vase.

5                   It is common practice for bouquets of flowers to be sent to patients in hospitals and other institutions, and very often vases are not available to accommodate bouquets. Also, when flowers are being shown at flower shows, competitors have to transport vases for showing the  
10                   flowers. Many of these vases are large as well as being easily damaged.

                  The present invention provides components for assembling a vase comprising a frame member adapted to be assembled to an erect condition to define a support for a  
15                   water container, and an outer sleeve adapted to fit over the erected frame to secure the frame member in its erected condition.

                  Advantageously, the components include a water container in the form of a bag, the bag being adapted to  
20                   be located in the erected frame and having its open end between the frame and the sleeve.

                  Advantageously, the frame member comprises a base to which are attached a plurality of side walls, and the outer sleeve comprises an equivalent number of

complementary side walls, the frame member and the  
outer sleeve being foldable from a substantially flat  
condition to an erect condition.

5 Preferably, the vase when assembled has a base  
of greater cross-sectional area than the mouth of the  
vase. An example of such a vase is a vase of a generally  
truncated pyramidal construction. The vase may be four  
sided and may also be provided with a square base.

10 Conveniently, the frame member comprises a pair  
of blanks, each blank comprising a base element and two  
side walls foldable from a flat condition to an erect  
condition, the two base elements being pivotally secured  
together so that said blanks may be in an overlying  
relationship when the vase is in the unassembled mode.

15 Advantageously, the outer sleeve is provided  
with flaps at its lower edge, said flaps being foldable to  
engage with the frame member. The flaps may be  
provided with an adhesive backing. The outer sleeve may  
also be provided with retaining means for a greeting  
20 card.

Conveniently the frame member and the outer  
sleeve are manufactured from card.

25 Preferably, the components include a bag for use  
as a watertight membrane. The bag may be of a plastics  
material, such as polyethylene.

If desired, a block of flower holding material such as urea formaldehyde foam, may be provided within the vase.

5 The invention will hereinafter be described more particularly with reference to the accompanying drawings which illustrate, by way of example only, a preferred embodiment thereof. In the drawings:

Figure 1 is a perspective view of a vase assembled from components according to the invention;

10 Figure 2 is a perspective exploded view of the vase showing a frame member, bag and outer sleeve; and

Figure 3 is a plan view of the frame member in a flat condition.

Referring to the drawings, the vase  
15 10 comprises a frame member 12, a polyethylene bag 13 and an outer sleeve 14. The frame member 12 comprises a pair of blanks 16, each of which has a base element 17 two side walls 18 and fold lines 19. The two blanks 16 are connected together by a rivet 21, to enable the blanks  
20 to be rotated from a position in which one lies upon the other, to the position in which the blanks lie generally at right angles to one another, as shown in Figure 3. From the cruciform position as shown, the four side walls 18 may be folded upwardly along the fold lines 19 to  
25 define a generally truncated pyramidal container.

The outer sleeve 14 comprises a single piece of material and has four side walls 22. The generally truncated pyramidal form is secured by means of the adhesive backed flap 23. Four adhesive backed flaps 25 are provided at the lower edge of the outer sleeve 14. When the outer sleeve 14 is positioned over the frame member 12 the adhesive flaps 25 are folded along the fold lines 26 and secured in position to the base 17 of the frame member 12. The outer sleeve 14 is also provided with a slot 27 for accommodating a greeting card.

A vase is formed by erecting a frame member 12 as described, inserting into the frame member a polyethylene bag 13, the mouth of the bag being folded outwardly and over the side walls 18 of the frame member, then bringing the outer sleeve 14 downwardly over the frame member, so as to secure the bag in position, and finally securing the adhesive flaps 25 to the base of the frame member.

It will be appreciated that the primary components of the vase, namely the frame member 12, the bag 13 and the outer sleeve 14 may be delivered to the potential user in a compact, flat condition which can readily be erected when required.

A block of flower holding material, such as urea formaldehyde foam, not shown, may be provided within the

vase. This block further enhances the flexibility of the vase in flower arranging.

5 The vases, when assembled, may be placed on a vacuum formed tray (also not shown). The trays provided with a plurality of wells each of which is adapted to support a vase. The under side of each tray is provided with a number of sponge pads which operate as non-slip elements and a frame is provided about the rim of the tray to act as a reinforcement. The tray facilitates delivery  
0 of prepared flower arrangements to hospitals and other institutions.

CLAIMS:

1. Components for assembling a vase comprising a frame member (12) adapted to be assembled to an erect condition to define a support for a water container (13) and an outer sleeve (14) adapted to fit over the erected frame member to secure the frame member in its erected condition.
2. Components for assembling a vase as claimed in Claim 1, including a water container in the form of a bag (13), the bag being adapted to be located in the erected frame and having its open end secured between the frame and the sleeve.
3. Components for assembling a vase as claimed in Claim 1 or Claim 2 in which the frame member comprises a base (17) to which is attached a plurality of side walls (18), and the outer sleeve comprises an equivalent number of complementary side walls (22), the frame member and the outer sleeve each being foldable from a substantially flat condition to an erect condition.
4. Components for assembling a vase as claimed in any one of the preceding claims, which when assembled provide a vase of a generally truncated pyramidal construction.
5. Components for assembling a vase as claimed in any one of the preceding claims, in which the frame

member comprises a pair of blanks (16), each blank comprising a base element (17) and two side walls (18) foldable from a flat condition to an erect condition, the two base elements being pivotally secured together so that said blanks may be in an overlying relationship when the vase is in the unassembled mode.

5

6. Components for assembling a vase as claimed in any one of the preceding claims, in which the outer sleeve is provided with flaps (25) at its lower edge, said flaps being foldable to engage with the frame member.

10

7. Components for assembling a vase as claimed in Claim 6, in which the flaps are provided with an adhesive backing.

8. Components for assembling a vase as claimed in any one of the preceding claims, in which the frame member and the outer sleeve are manufactured from card.

15

9. Components for assembling a vase as claimed in Claim 2, in which the bag is of a plastics material.

10. A vase whenever constructed from components as claimed in any one of the preceding claims.

20



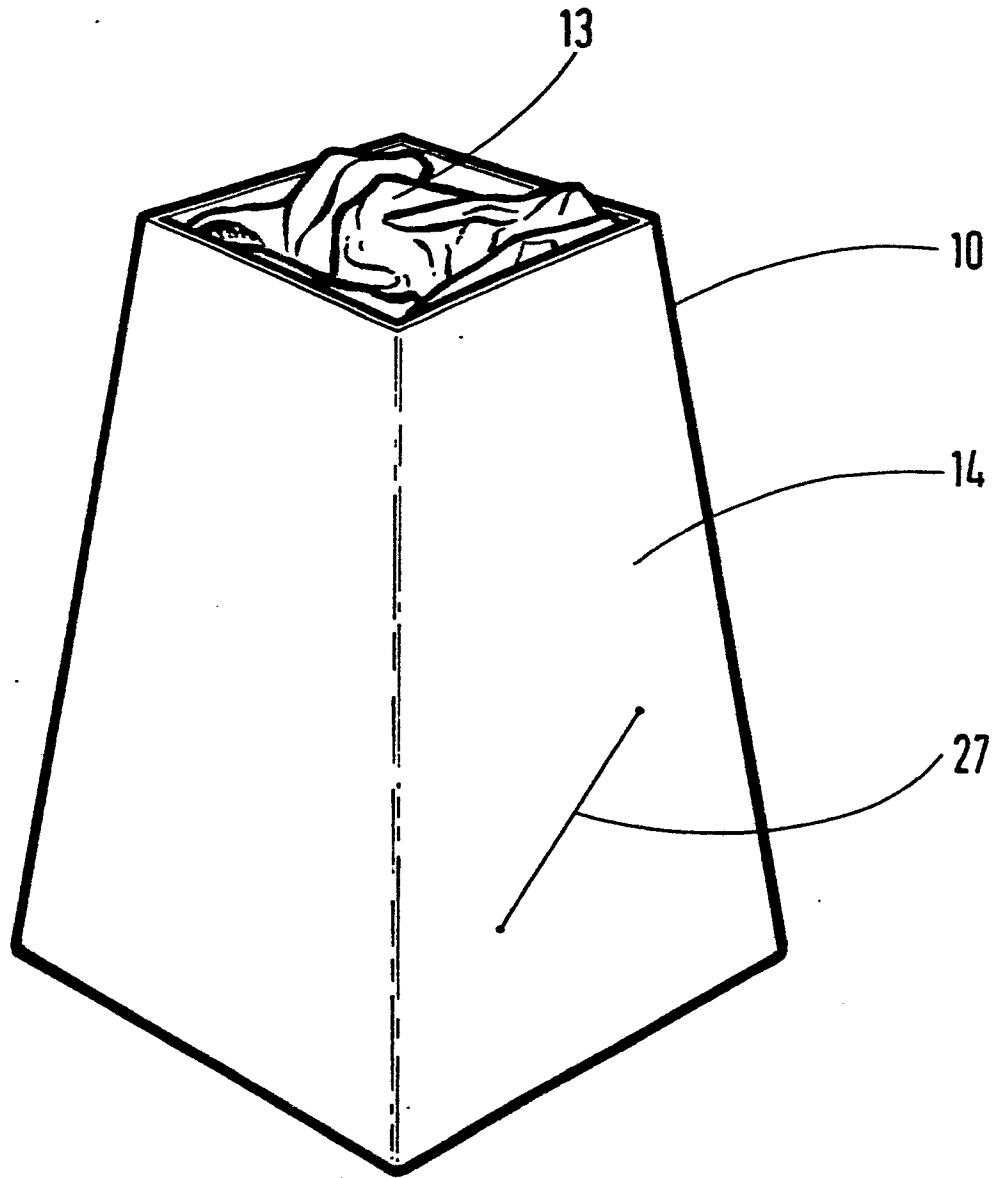

FIG. 1

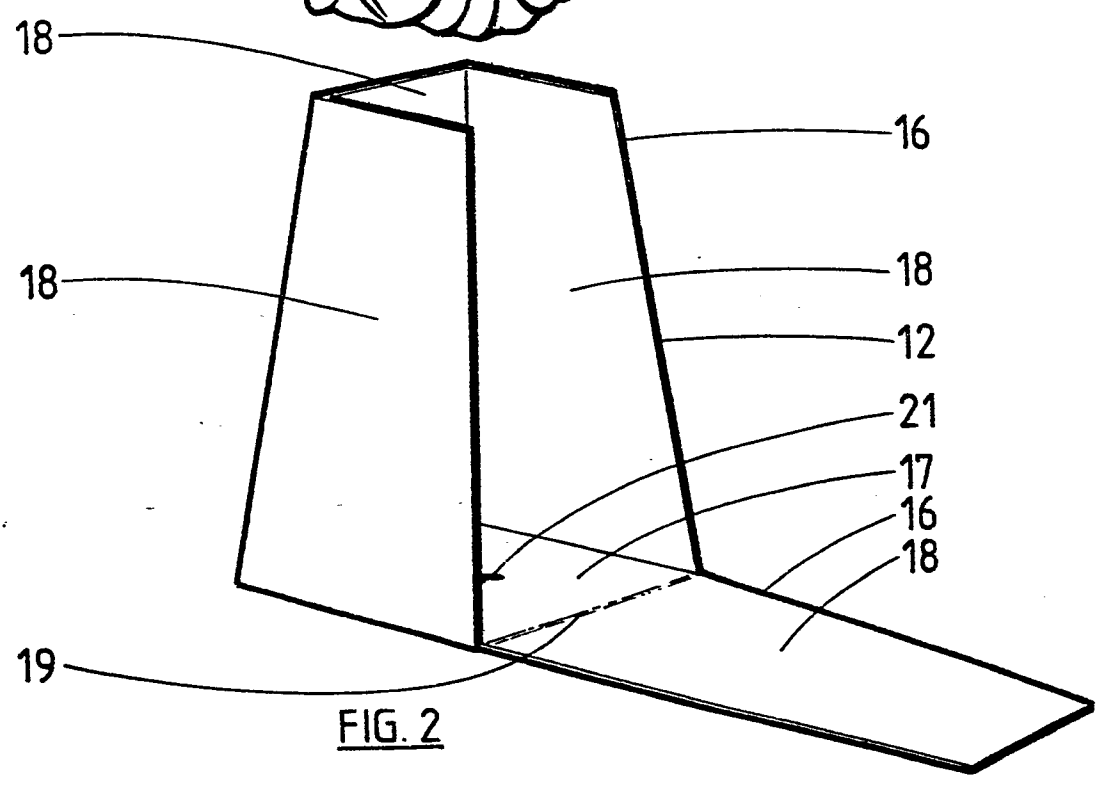
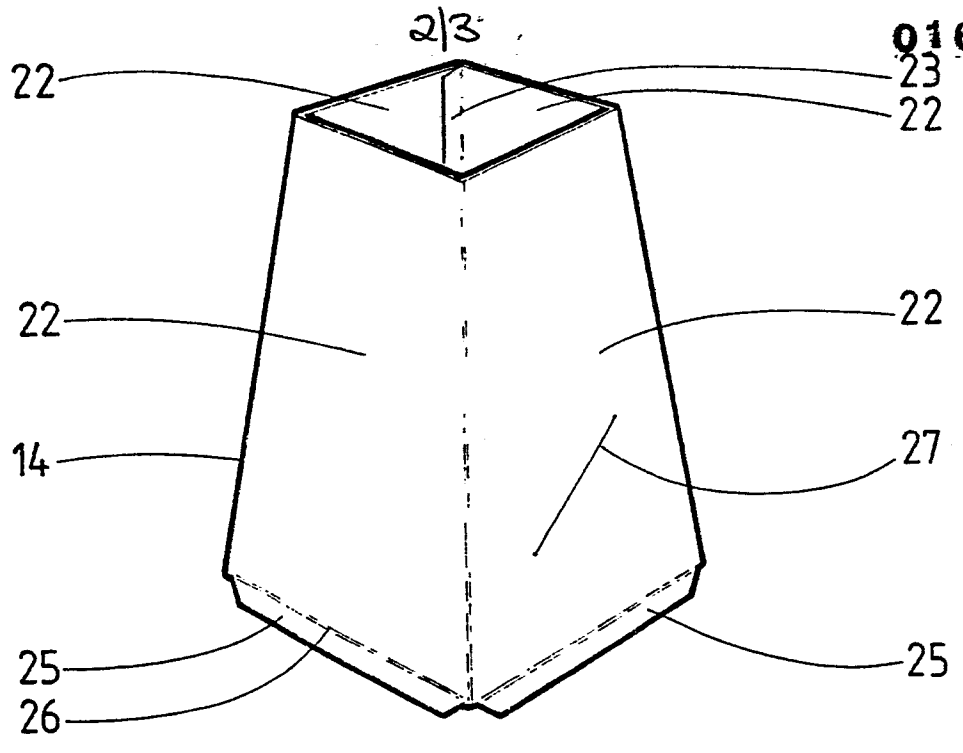

FIG. 2

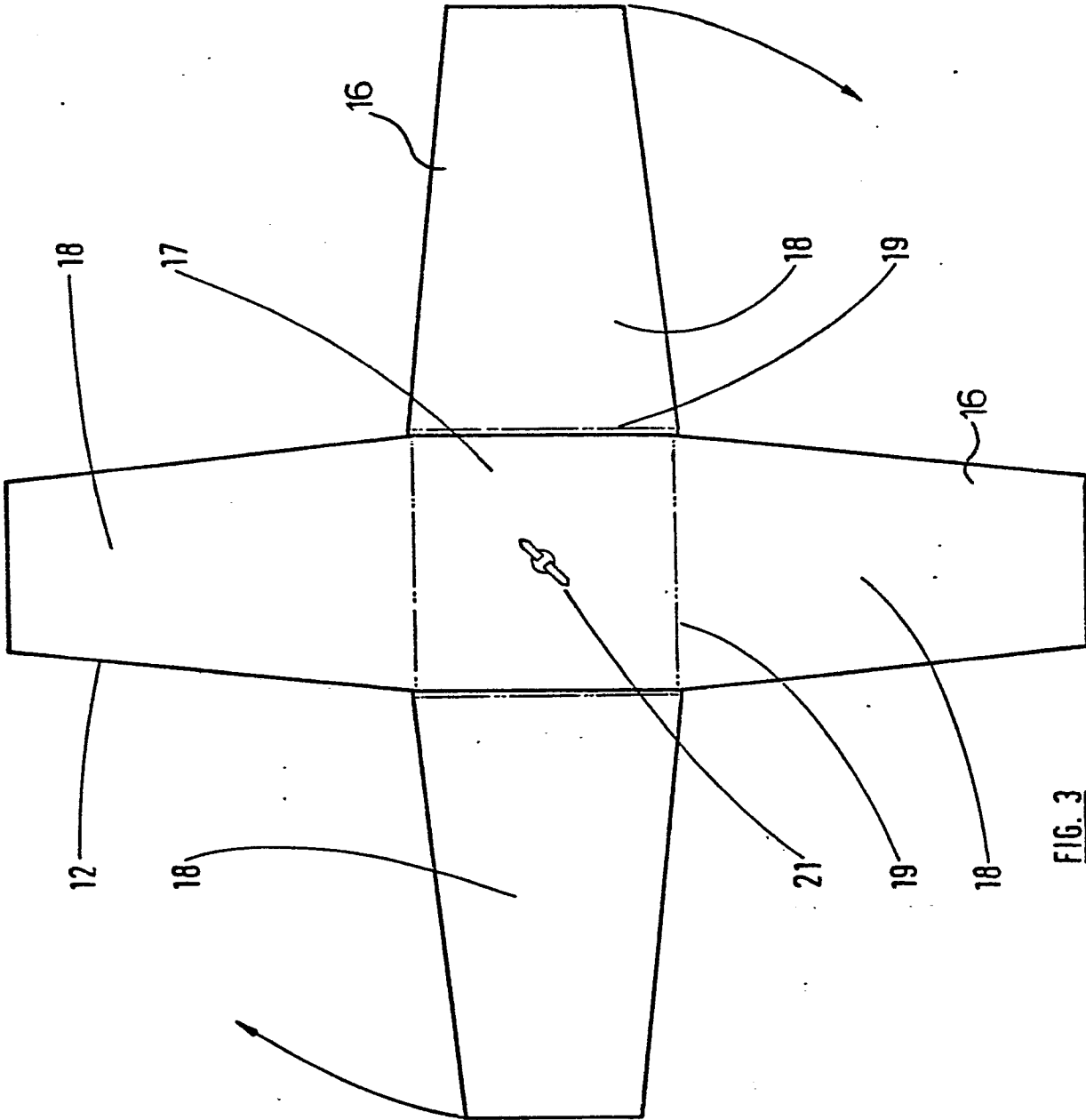

FIG. 3



| DOCUMENTS CONSIDERED TO BE RELEVANT   |   |  |  |
|---|---|--|--|
| Category  | Citation of document with indication, where appropriate, of relevant passages                     | Relevant to claim                              | CLASSIFICATION OF THE APPLICATION (Int. Cl.4)                          |
| Y   | DE-A-2 923 455 (BANK)<br>* Page 8, paragraph 3 - page 10,<br>paragraph 1; figures 1-6 *           | 1,2,10   | A 47 G 7/06  |
| A   |   | 3-5,7-9  |  |
| Y   | ---<br>US-A-2 916 183 (ARIENS)<br>* Whole document *  | 1,2,10   |  |
| A   |   | 3  |  |
| A   | ---<br>DE-A-2 817 803 (JANSSEN)<br>* Page 9, paragraph 5 - page 14,<br>paragraph 2; figures 1-4 * | 1-3,6,8,10                                     |  |
| A   | ---<br>US-A-3 985 285 (YOSHIKO<br>KITAGAWA)<br>* Claim 1 *  | 5  | TECHNICAL FIELDS<br>SEARCHED (Int. Cl.4)<br>A 01 G<br>A 47 G<br>B 65 D |
| -----   |   |  |  |
| The present search report has been drawn up for all claims  |   |  |  |
| Place of search<br>THE HAGUE  |   | Date of completion of the search<br>23-08-1985 | Examiner<br>HERYGERS J.J.  |
| <b>CATEGORY OF CITED DOCUMENTS</b><br>X : particularly relevant if taken alone<br>Y : particularly relevant if combined with another document of the same category<br>A : technological background<br>O : non-written disclosure<br>P : intermediate document<br>T : theory or principle underlying the invention<br>E : earlier patent document, but published on, or after the filing date<br>D : document cited in the application<br>L : document cited for other reasons<br>& : member of the same patent family, corresponding document |   |  |  |