



US 20060137268A1

(19) **United States**

(12) **Patent Application Publication**  
**Trageser et al.**

(10) **Pub. No.: US 2006/0137268 A1**

(43) **Pub. Date: Jun. 29, 2006**

(54) **CONTINUOUS MATTING SURFACE**

**Related U.S. Application Data**

(76) Inventors: **Andrew B. Trageser**, Pittsburgh, PA (US); **Matthew P. Kiley**, Allison Park, PA (US); **Richard A. Sokol**, Harrison City, PA (US); **Jeffrey D. Caratelli**, Leechburg, PA (US); **Robert P. Evert**, Allison Park, PA (US); **Angel L. Rosario**, Aurora, IL (US); **Jeff L. Day**, Elburn, IL (US); **Albert E. Wills JR.**, Orwigsburg, PA (US)

(60) Provisional application No. 60/619,890, filed on Oct. 18, 2004.

**Publication Classification**

(51) **Int. Cl.**  
**E04B 1/32** (2006.01)  
(52) **U.S. Cl.** ..... **52/248**

(57) **ABSTRACT**

A matting surface having a first flooring member and a second flooring member is disclosed. The first flooring member is substantially parallel to the second flooring member. Both flooring members have an end with an extending tabular member and a grooved end that is structured to slideably receive the extending tabular end of an adjacent flooring member thereby forming a joint between the flooring members and the adjacent flooring members. The first and second flooring members having means of connecting and interlocking the first flooring member to the second flooring member.

Correspondence Address:

**INTELLECTUAL PROPERTY**  
**ALCOA TECHNICAL CENTER, BUILDING C**  
**100 TECHNICAL DRIVE**  
**ALCOA CENTER, PA 15069-0001 (US)**

(21) Appl. No.: **11/252,096**

(22) Filed: **Oct. 17, 2005**

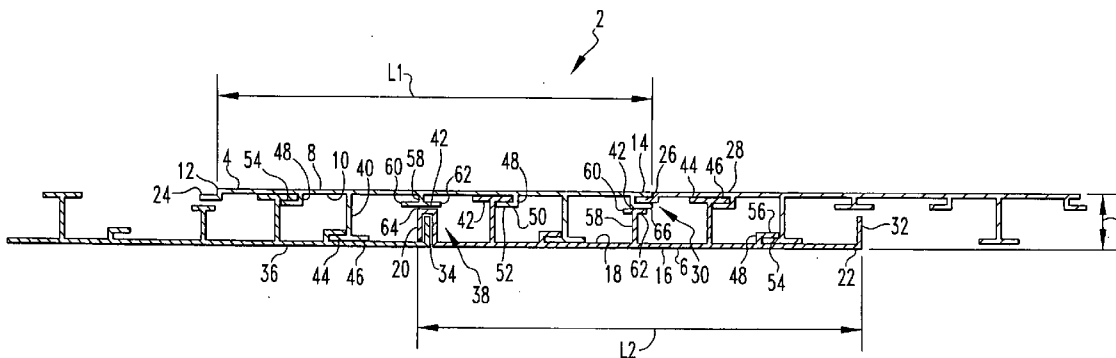



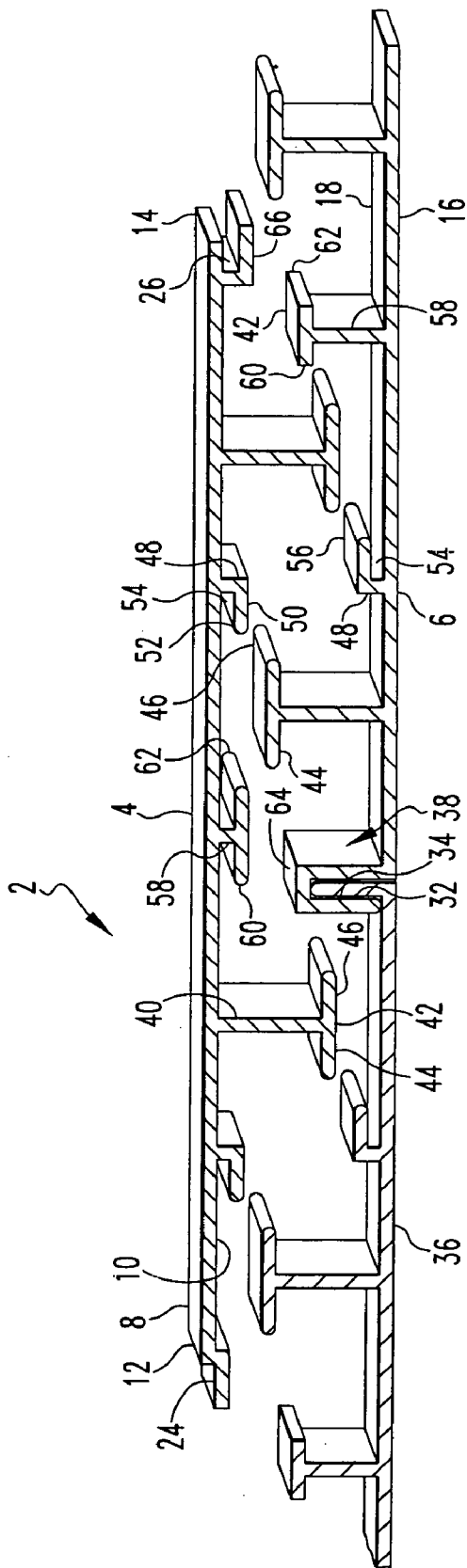

FIG. 2

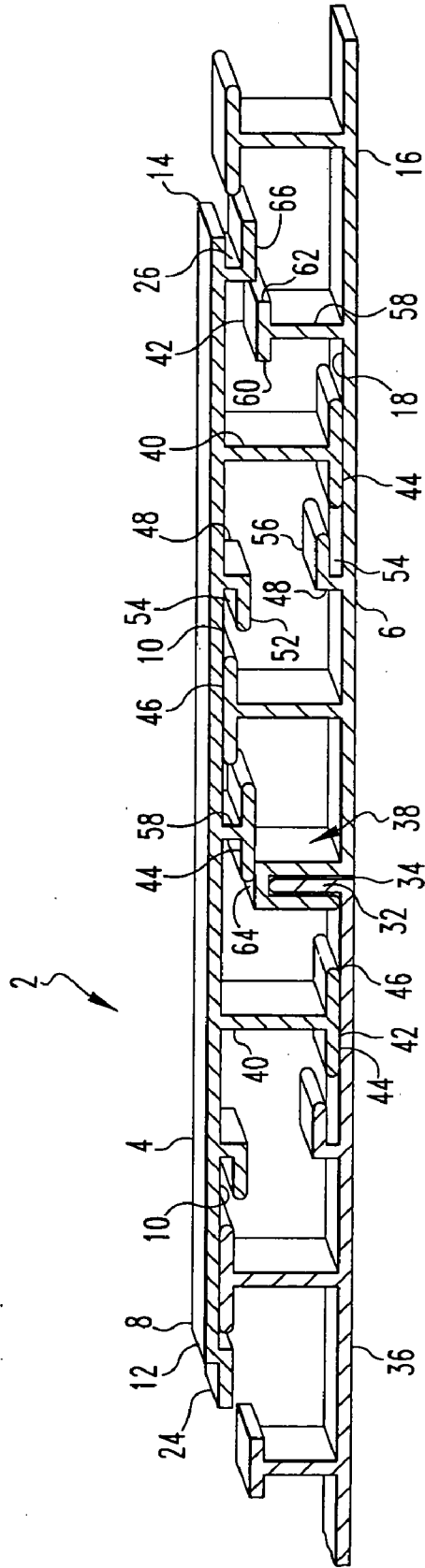

FIG. 3

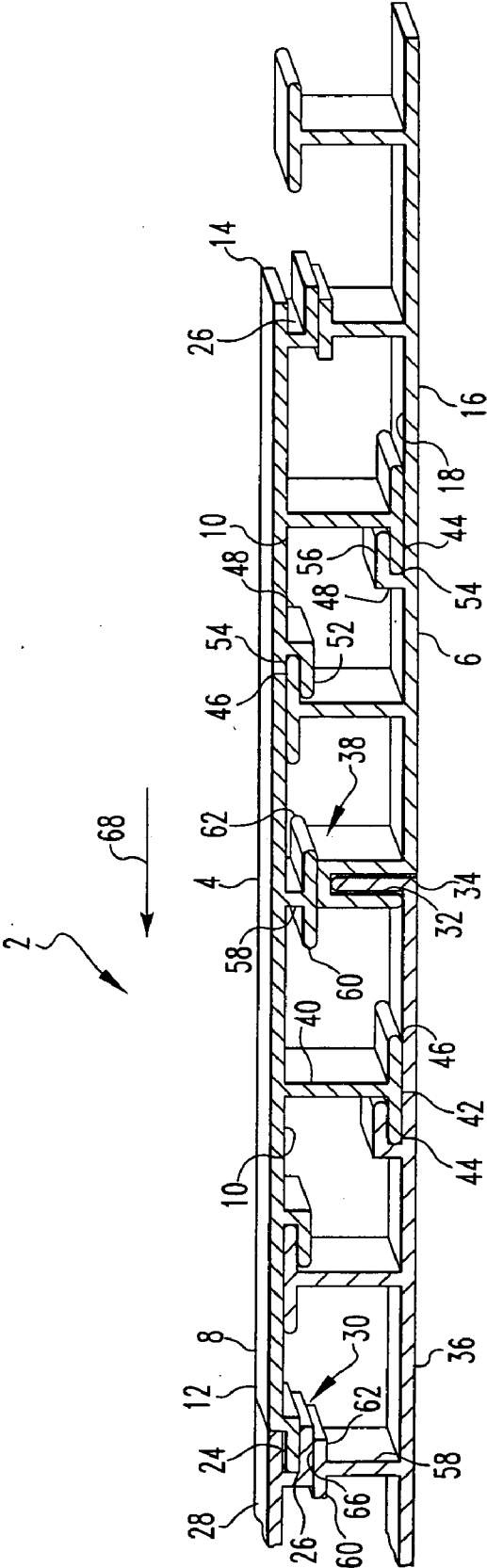

FIG. 4

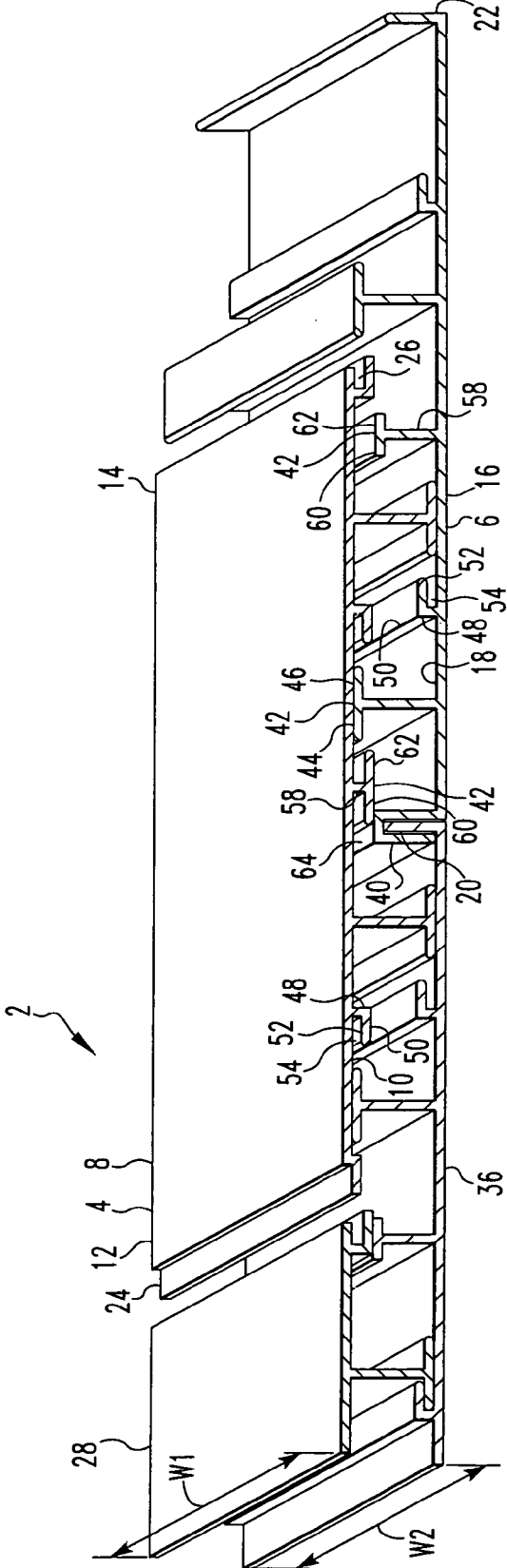
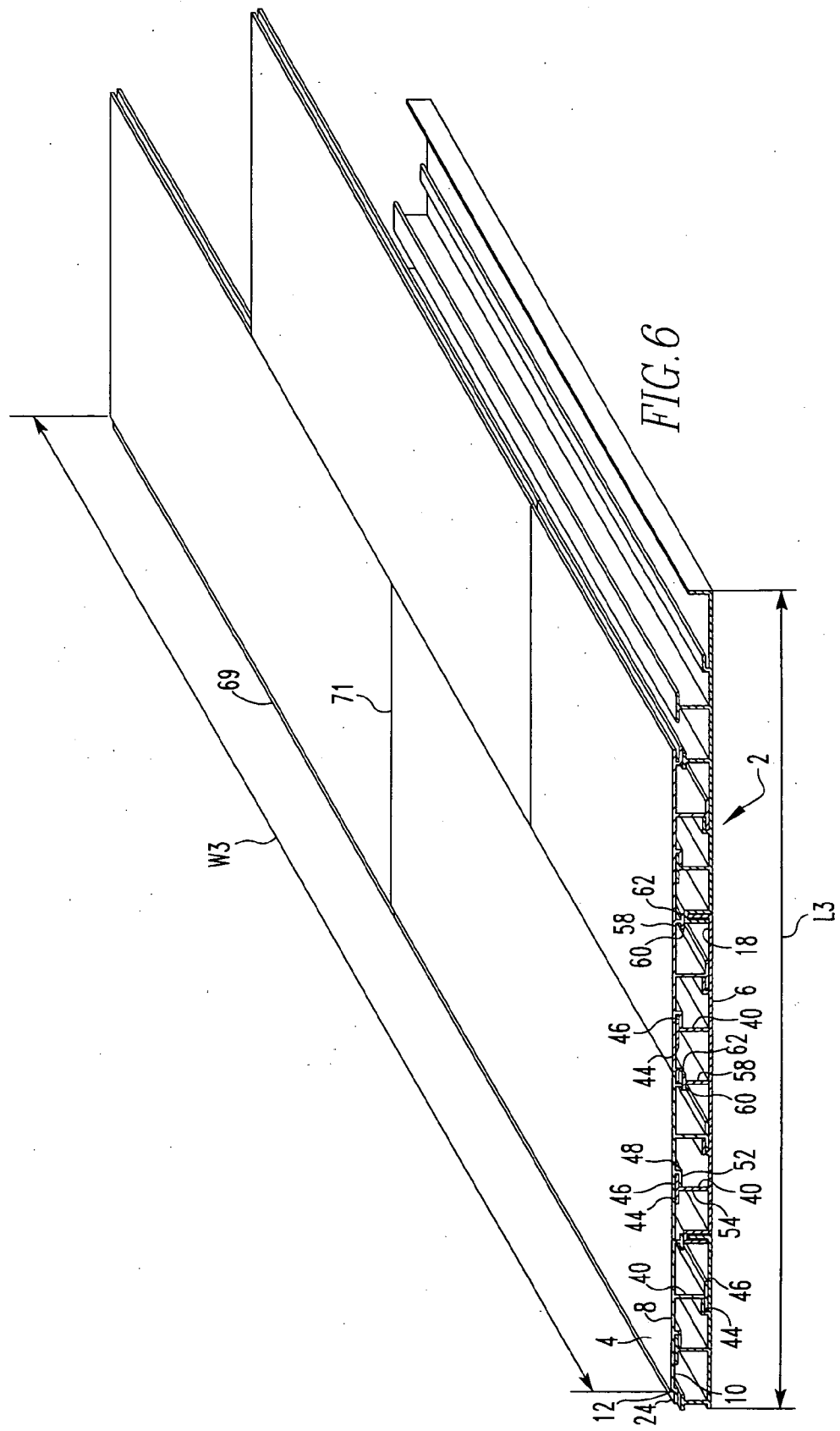

FIG. 5



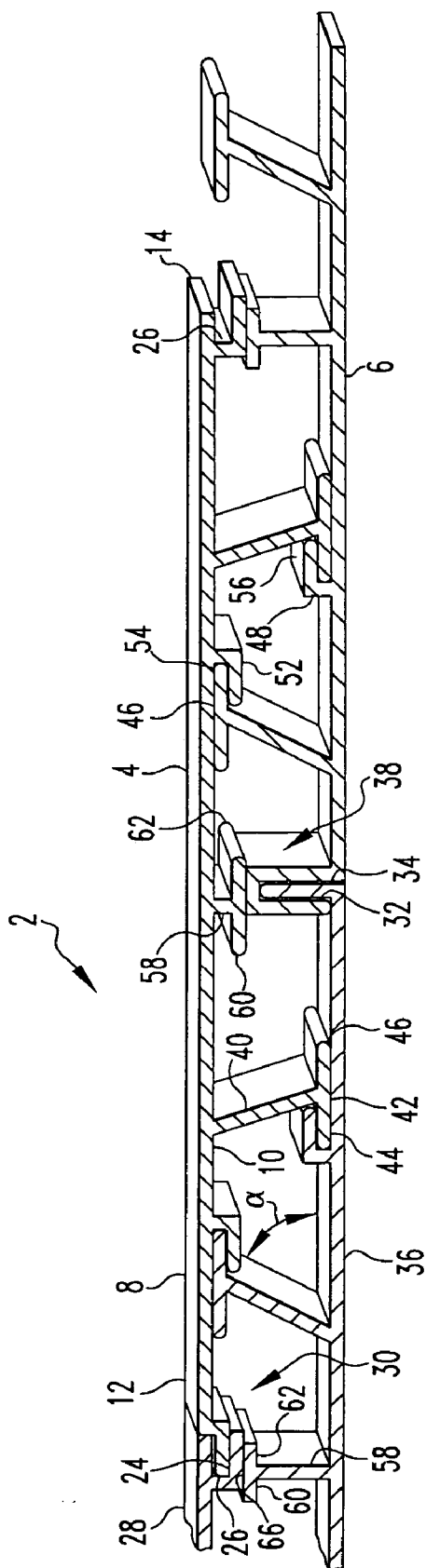

FIG. 7



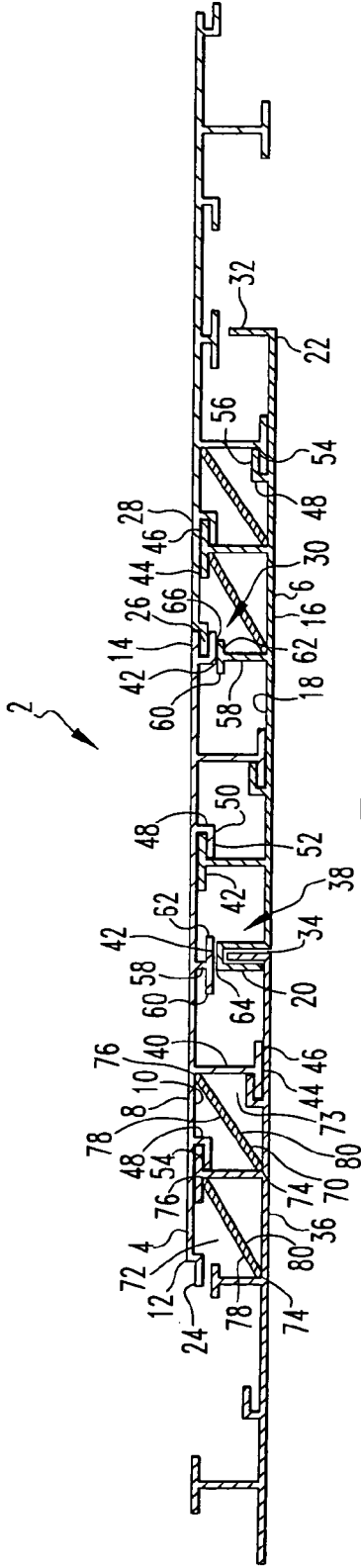

FIG. 8

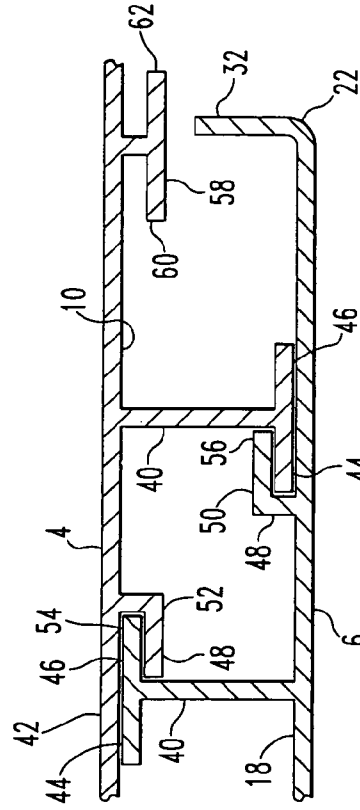

FIG. 9

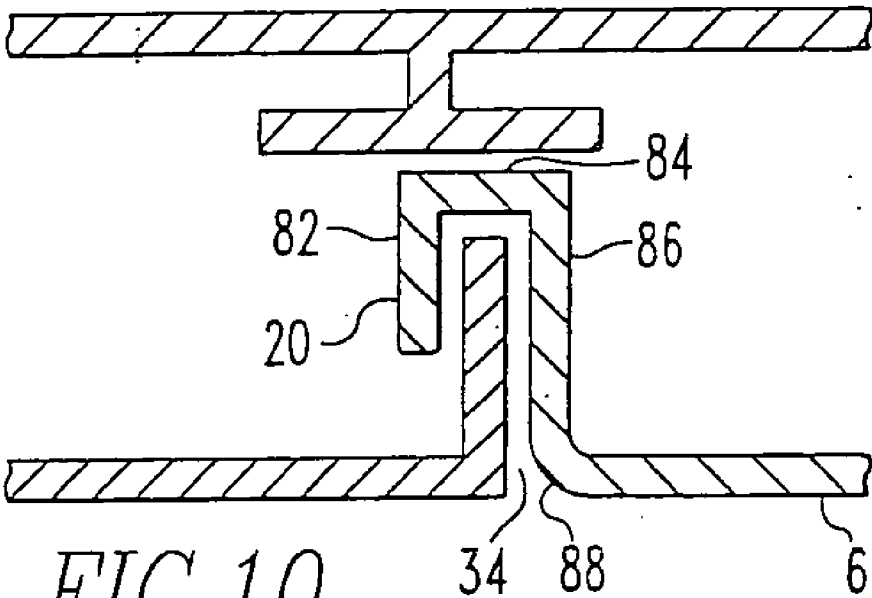

FIG. 10

**CONTINUOUS MATTING SURFACE**

**CROSS REFERENCE TO RELATED APPLICATIONS**

[0001] This application claims the benefit of U.S. Provisional Application Ser. No. 60/619,890, filed on Oct. 18, 2004, the disclosure of which is fully incorporated by reference herein.

**FIELD OF THE INVENTION**

[0002] This invention relates generally to matting surfaces. In particular, this invention is directed towards an improved matting surface that is capable of being installed over a variety of foundations while exhibiting resistance to bending in several directions.

**BACKGROUND OF THE INVENTION**

[0003] Prior to the installation of a patio, sidewalk, roadway, driveway, or shed floor installers have had to prepare the installation site in order to ensure that a proper (level) foundation is laid. Most pre-installation methods are labor intensive and time consuming since the methods often involve excavating, compacting and leveling sub-soil, installing gravel, edging, and installing a sand base. However, even if a proper and stable foundation was laid the patio, sidewalk, roadway, driveway, or shed floor would still be susceptible to rutting due to rain water and normal traffic loads (wear and tear).

[0004] Today, flat-bed trailer decks are constructed by combining a series of longitudinal aluminum extrusions that are supported by a number of cross-members that are then connected to two main chassis rails located on the trailer. The cross-members are used to strengthen the structure to resist transverse bending. However, this configuration of longitudinal extrusions and cross-members is neither weight efficient nor cost effective. Additionally, this configuration also limits the height of the load that can be carried on the flat-bed trailer.

[0005] The construction of floors in step vans, truck cabs and sleepers, and passenger rail cars are also constructed using decking attached to cross members and other sub-flooring for lateral support. Sub-flooring is often needed since the decking material provides resistance to bending primarily in one direction.

[0006] Therefore, there exists a need for a matting surface that can be installed over a soft foundation with minimal site preparation. Additionally, there is a need for a matting or decking surface that can reduce the height of a flat-bed trailer or other transportation vehicle.

[0007] This invention is a response to these needs by providing a matting surface that can be installed over a soft foundation while reducing the time and costs associated with installing the mat. This invention is also a response to the need for reducing the height of a flat-bed trailer by providing a matting surface or deck that will allow the elimination of some components that are typically required for such a trailer.

**SUMMARY OF THE INVENTION**

[0008] This invention describes a matting surface that can carry loads over soft foundations. The matting surface

includes a first flooring member and a second flooring member. The first flooring member has a first end that has an extending tabular member and a second end that has a groove that is structured to slideably receive the extending tabular member of an adjacent first flooring member thereby forming a joint between the first flooring member and the adjacent first flooring member. The second flooring member has a second end that has an extending tabular member and a first end that has a groove that is structured to slideably receive the extending tabular member of an adjacent second flooring member thereby forming a joint between the second flooring member and the adjacent second flooring member. The first and second flooring members have means for connecting and interlocking the first flooring member to the second flooring member. When connected and interlocked, the first flooring member is offset from the second flooring member.

[0009] In one embodiment, the means for interconnecting the first and second flooring members are one or more integrally extruded T-brackets, L-brackets, and support T-brackets that extend from an interior surface. The T-brackets function as a web to hold the first and second flooring members apart while the L-brackets are used as a hook or receptacle for the T-brackets thereby interconnecting the first flooring member to the second flooring members. Each of the first and second flooring members has the integrally extruded brackets. The T-brackets and L-brackets extend substantially perpendicularly from the interior surface thereby allowing the T-bracket to be received into the groove that is formed between the L-brackets and the interior surface of the first and second flooring members. When the T-brackets are received into the groove formed between the L-bracket and interior surface, the first and second flooring members are interconnected. The support T-brackets that are attached to and extend from the first flooring member extend perpendicularly from the interior surface of the support T-brackets are located adjacent to and are in contact with the joint formed between the second flooring members and the adjacent second flooring member. The support T-brackets that are attached to and extend from the second flooring member extend perpendicularly from the interior surface of the second flooring member. The top of these support T-brackets are located adjacent to and are in contact with the joint formed between the first flooring members and the adjacent first flooring member.

[0010] This invention also describes a method for making such a matting surface. The method includes providing a first and second flooring member with T-brackets and L-brackets extending from the interior surface of each flooring member, positioning the first flooring member so that the T-brackets that extend from the first flooring member are positioned adjacent to the groove that is formed between the L-brackets that extend from the second flooring member and the interior surface of the second flooring member and that the T-brackets that extend from the second flooring member are positioned adjacent to a groove that is formed between the L-brackets that extend from the first flooring member and the interior surface of the first flooring member, and interlocking the first flooring member to the second flooring member by slidingly moving the first flooring member in a lateral direction whereby that T-brackets are received into the groove.

[0011] An aspect of this invention is to provide a matting surface that is inexpensive, lightweight, corrosion resistant, durable, and capable of being installed over a variety of foundations while exhibiting resistance to bending in several directions.

[0012] Another aspect of this invention is to provide a matting surface that is inexpensive, lightweight, corrosion resistant, durable, and able to loads over soft foundations.

[0013] Another aspect of this invention is to provide a matting surface that reduces the amount of time needed to install the mat.

[0014] Yet another aspect of this invention is to provide a matting surface that decreases the cost, the amount of transport vehicles, and the time needed to transport the mat to the desired location.

[0015] Another aspect of this invention is to reduce the height of a flat-bed trailer.

#### BRIEF DESCRIPTION OF THE DRAWINGS

[0016] **FIG. 1** is a cross-sectional schematic view of one preferred embodiment of the present invention. In **FIG. 1**, the first flooring member and the second flooring member are interconnected to one another.

[0017] **FIG. 2** shows a disengaged first flooring member and second flooring member.

[0018] **FIG. 3** shows the position of the first flooring member in relation to the second flooring member prior to interconnection.

[0019] **FIG. 4** is a schematic showing the first and second flooring members interconnected.

[0020] **FIG. 5** is a perspective view showing the position of the first and second flooring members prior to interconnection.

[0021] **FIG. 6** is a perspective view showing how multiple first and second flooring members are interconnected to form a large matting surface.

[0022] **FIG. 7** is a schematic showing T-brackets that extend from the interior surface of the first and second flooring member at an angle less than about 90°.

[0023] **FIG. 8** depicts a key that is inserted between the first and second flooring members in order to provide structural support to the matting surface.

[0024] **FIG. 9** depicts another embodiment of the second flooring member.

[0025] **FIG. 10** depicts yet another embodiment of the second flooring member.

#### DETAILED DESCRIPTION OF PREFERRED EMBODIMENTS

[0026] The accompanying drawings and the description which follows set forth this invention in its preferred embodiment. However, it is contemplated that persons generally familiar with panel, decking, and flooring systems will be able to apply the novel characteristics of the structures and methods illustrated and described herein in other contexts by modification of certain details. Accordingly, the drawings and description are not to be taken as restrictive on

the scope of this invention, but are to be understood as broad and general teachings. When referring to any numerical range of values, such ranges are understood to include each and every number and/or fraction between the stated range minimum and maximum. Finally, for purposes of the description hereinafter, the terms “upper”, “lower”, “right”, “left”, “vertical”, “horizontal (lateral)”, “top”, “bottom”, and derivatives thereof shall relate to the invention, as it is oriented in the drawing figures.

[0027] In **FIG. 1** the matting surface 2 includes a first flooring member 4 that is substantially parallel and offset to a second flooring member 6. The first flooring member 4 could be of differing lengths from the second flooring member 6 and can be offset from the second flooring member 6 in other directions as well. The first flooring member 4 has an exterior surface 8, an interior surface 10, a first end 12, and a second end 14. The second flooring member 6 also has an exterior surface 16, an interior surface 18, a first end 20, and a second end 22. The first end 12 of the first flooring member 4 has a substantially laterally extending tabular member 24 that is adjacent to the interior surface 10. The second end 14 of the first flooring member 4 has a groove 26 that is structured to slideably receive the substantially laterally extending tabular member 24 of an adjacent first flooring member 28 thereby forming a joint 30 between the first flooring member 4 and the adjacent first flooring member 28. The second end 22 of the second flooring member 6 has a substantially vertically extending tabular member 32. The first end 20 of the second flooring member 6 has a groove 34 that is structured to slideably receive the substantially vertically extending tabular member 32 of an adjacent second flooring member 36 thereby forming a joint 38 between the second flooring member 6 and the adjacent second flooring member 36.

[0028] The first and second flooring members 4 and 6 each have a plurality of T-brackets 40. Despite the fact that **FIG. 1** depicts the first and second flooring member 4, 6 as each having a plurality of T-brackets 40, it is noted that one skilled in the art would recognize that one or more T-brackets 40 extend from the interior surfaces 10, 18 of the first and second flooring members 4,6. The T-brackets 40 have a top 42 that has a first laterally extending tabular member 44 and a second laterally extending tabular member 46. It is noted, however, that despite the fact that **FIGS. 1-8** depict the first and second laterally extending tabular members 44, 46 as being equal in length, one skilled in the art would recognize that the first and second laterally extending tabular members 44 and 46 could have differing lengths. The T-brackets 40 are attached to and extend substantially perpendicular from the interior surface 10 of the first flooring member 4 and the interior surface 18 of the second flooring member 6 so that the first and second tabular members 44, 46 are substantially parallel to but not in contact with the interior surfaces 10, 18 from which they extend.

[0029] The first flooring member 4, as depicted in **FIG. 1**, has a plurality of L-brackets 48. One skilled in the art, however, would recognize that one or more L-brackets 48 may be attached to and extend from the first flooring member 4 and not depart from the teachings of the present invention. The L-brackets 48 have a top 50 that has a first laterally extending tabular member 52. The L-brackets 48 are attached to and extend substantially perpendicular from the interior surface 10 of the first flooring member 4 so that

the first laterally extending tabular member 52 is substantially parallel to but not in contact with the interior surface 10 thereby forming a groove 54 between the first laterally extending tabular member 52 and the interior surface 10 of the first flooring member 4. The groove 54 slideably receives the second extending tabular member 46 of one or more T-brackets 40, which extend from the second flooring member 6 and one or more T-brackets 40 that extend from the adjacent second flooring member 36 thereby interlocking the first flooring member 4 to the second flooring member 6 and the adjacent second flooring member 36.

[0030] The second flooring member 6, as depicted in FIG. 1, has a plurality L-brackets 48. However, one skilled in the art would recognize that one or more L-brackets 48 may be attached to and extend from the second flooring member 6 and not depart from the teachings of the present invention. The L-brackets 48 have a top 50 that has a second laterally extending tabular member 56. The L-brackets 48 are attached to and extend substantially perpendicular from the interior surface 18 of the second flooring member 6 so that the second laterally extending tabular member 56 is substantially parallel to but not in contact with the interior surface 18 thereby forming a groove 54 between the second laterally extending tabular member 56 and the interior surface 18 of the second flooring member 6. The groove 54 slideably receives the first extending tabular member 44 of the T-brackets 40, which extend from the first flooring member 4 and the T-brackets 40 that extend from the adjacent first flooring member 28 thereby interlocking the second flooring member 6 to the first flooring member 4 and the adjacent first flooring member 28.

[0031] In one embodiment, the T-brackets 40 that interconnect the first and second flooring members 4, 6 could have an angle that is less than or greater than about 90°. One skilled in the art would also appreciate that the first flooring member 4 could only have T-brackets 40 while the second flooring member 6 could only have L-brackets 48 or vice versa. Additionally, one skilled in the art would recognize that the T- and L-brackets 40, 48 could be replaced or used in combination with other brackets that are selected from a group having an E-, F-, H-, I-, N-, M-, W-, and Z-shape. It can also be appreciated that a bracket, which extends from each of the interior surfaces 10, 18, having one or more laterally extending tabular members may also be used as a means of connecting and interlocking the first and second flooring members 4, 6. Such brackets could also extend from the interior surface 10, 18 at a 90° angle or at an angle that is less than or greater than 900.

[0032] The first flooring member 4 and the second flooring member 6, as depicted in FIG. 1, both have one support T-bracket 58. It is noted, however, that one skilled in the art would recognize that one or more support T-brackets 58 may be attached to and extend from each of the first and second flooring members 4, 6 and not depart from the teachings of this invention. One skilled in the art would also appreciate that the support T-brackets 58 may be replaced by a support bracket that has one or more laterally extending tabular members. For instance, the support T-brackets 58 may be replaced by support brackets that have an L-shape. The support T-brackets 58, in FIG. 1, have a top 42 that has a first laterally extending tabular member 60 and a second laterally extending tabular member 62. It is noted, however, that despite the fact that FIGS. 1-7 depict the first and

second laterally extending tabular members 60, 62 as being equal in length, one skilled in the art would recognize that the first and second laterally extending tabular members 60, 62 could have differing lengths. The support T-brackets 58 are attached to and extend substantially perpendicular from the interior surface 10 of the first flooring member 4 and the interior surface 18 of the second flooring member 6 so that the first and second tabular members 60, 62 are substantially parallel to but not in contact with the interior surfaces 10, 18 from which they extend. As depicted in FIG. 1, the first and second laterally extending tabular members 60, 62 on the support T-brackets 58 of the first flooring member 4 are located adjacent to and in contact with a surface 64 of the joint 38 that interconnects the second flooring member 6 to an adjacent second flooring member 36. The first and second laterally extending tabular members 60, 62 on the support T-brackets 58 extending from the second flooring member 6 are located adjacent to and in contact with a surface 66 of the joint 30 that interconnects the first flooring member 4 to an adjacent first flooring member 28.

[0033] Referring to FIG. 1, in one embodiment the distance L1 between the first end 12 and the second end 14 of the first flooring member ranges from about 15.24 cm (6 in) to about 76.2 (30 in). In another embodiment, the distance L1 between the first end 12 and the second end 14 of the first flooring member ranges from about 25.4 (10 in) to about 63.5 (25 in). In yet another embodiment, the distance L1 between the first end 12 and the second end 14 of the first flooring member is about 30.48 cm (12 in). In one embodiment the distance L2 between the first end 20 and the second end 22 of the second flooring member ranges from about 15.24 cm (6 in) to about 76.2 (30 in). In another embodiment, the distance L2 between the first end 20 and the second end 22 of the first flooring member ranges from about 25.4 (10 in) to about 63.5 (25 in). In yet another embodiment, the distance L2 between the first end 20 and the second end 22 of the first flooring member is about 30.48 cm (12 in). In one embodiment, the height H of the matting surface 2 ranges from about 0.635 cm (0.25 in) to about 25.4 cm (10 in). In another embodiment, the height H of the matting surface 2 ranges from about 0.635 cm (0.25 in) to about 2.54 cm (1.0 in). In yet another embodiment, the height H of the matting surface 2 is about 1.27 cm (0.5 in). In another embodiment, the height H of the matting surface 2 is about 3.81 cm (1.5 in).

[0034] FIGS. 2-4 depict how the matting surface is installed. As can be seen in FIG. 2, the second flooring member 6 is interconnected to an adjacent second flooring member 36 by slidingly receiving the vertically extending tabular member 32 of the adjacent second flooring member 36 into the groove 34 of the second flooring member 6 thereby forming a joint 38 between the second flooring member 6 and the adjacent second flooring member 36. As depicted in FIG. 3, the first flooring member 4 is then positioned above and offset to the interconnected second flooring member 6 and adjacent second flooring member 36 so that the first laterally extending tabular member 60 of the support T-bracket 58 that extend from the first flooring member 4 is located adjacent to and in contact with a surface 64 of the joint 38 that connects the second flooring member 6 and the adjacent second flooring member 36. In this position, the first laterally extending tabular member 44 of the T-brackets 40 that extend from the first flooring member 4 is adjacent to and in contact with the interior surface 18 of

the second flooring member 6 and is laterally adjacent to the groove 54 that is formed between the second laterally extending tabular member 56 of the L-brackets 48 that extend from the second flooring member 6 and the interior surface 18 of the second flooring member 6. Additionally, in this position the second laterally extending tabular member 46 of the T-brackets 40 that extend from the second flooring member 6 is adjacent to and in contact with the interior surface 10 of the first flooring member 4 and is laterally adjacent to the groove 54 that is formed between the first laterally extending tabular member 52 of the L-brackets 48 that extend from the first flooring member 4 and the interior surface 10 of the first flooring member 4. After interconnecting the first flooring member 4 and the second flooring member 6, a plug (not shown) may be inserted between the T-brackets 40 to further interlock and add stiffness (i.e. structural support) to the connected first and second flooring members 4, 6. The plug may be manufactured from a plastic, polymer, rubber, or metallic substance.

[0035] Referring to FIG. 4, when the first flooring member 4 is moved in a lateral direction represented by arrow 68, the laterally extending tabular member 24 of the first flooring member 4 is slideably received into the groove 26 of an adjacent first flooring member 28 thereby connecting and forming a joint 30 between the first flooring member 4 and the adjacent first flooring member 28. The lateral movement 68 also causes the second laterally extending tabular member 46 of the T-brackets 40 that extend from the second flooring member 6 to be slideably received into the groove 54 that is formed between the interior surface 10 of the first flooring member 4 and the first laterally extending tabular member 52 of the L-bracket that extends from the first flooring member 4 thereby interlocking the first and second flooring members 4, 6. In addition, the lateral movement 68 causes the first laterally extending tabular member 44 of the T-brackets 40 that extend from the first flooring member 4 to be slideably received into the groove 54 that is formed between the interior surface 18 of the second flooring member 6 and the second laterally extending tabular member 56 of the L-brackets 48 that extend from the second flooring member 6 thereby further interlocking the first and second flooring members 4, 6. The lateral movement 68 also causes the joint 38 that connects the second flooring member 6 and the adjacent second flooring member 36 to be located substantially between the first laterally extending tabular member 60 and the second laterally extending tabular member 62 of the support T-bracket 58 that extend from the first flooring member 4.

[0036] FIG. 5 is a perspective view showing the position of the first and second flooring members 4, 6 prior to interconnecting the first and second flooring members 4, 6. As can be seen from this figure, the width W1 of the first flooring member 4 and adjacent first flooring members 26 ranges from about 15.24 cm (6 in) to about 76.2 (30 in). In another embodiment, the width W1 of the first flooring member 4 and adjacent first flooring members 28 ranges from about 25.4 cm (10 in) to about 50.8 cm (20 in). In yet another embodiment, the width W1 of the first flooring member 4 and adjacent first flooring members 28 ranges from about 30.48 cm (12 in) to about 45.72 cm (18 in). Referring to FIG. 5, the width W2 of the second flooring member 6 and adjacent second flooring members 36 ranges from about 15.24 cm (6 in) to about 76.2 (30 in). In another embodiment, the width W2 of the second flooring member

6 and adjacent second flooring members 36 ranges from about 25.4 cm (10 in) to about 50.8 cm (20 in). In yet another embodiment, the width W2 of the second flooring member 6 and adjacent second flooring members 36 ranges from 30.48 cm (12 in) to about 45.72 cm (18 in).

[0037] FIG. 6 is a perspective view showing how the first and second flooring members 4, 6 are interconnected with adjacent first and second flooring members 28, 36 to form a large mat. As can be seen from this figure, the total length L3 as well as the total width W3 of the matting surface 2 may be increased by adding additional first and second flooring members 4, 6. In one embodiment, the total width W3 of the matting surface 2 is increased by welding a second first flooring member 69 to the first flooring member 4 along the joint 71 that is formed between the first flooring member 4 and the second first flooring member 69. In yet another embodiment, the total width W3 of the matting surface 2 is increased by mechanically fastening the first flooring member 2 to the second first flooring member 69.

[0038] FIG. 7 is a schematic showing how the T-brackets 40 can have an angle  $\alpha$  that is less than about 90°. One skilled in the art would appreciate that the T-bracket 40 could also have an integrated laterally extending tabular member near about the T-bracket's 40 base thereby providing a groove in which the first or second laterally extending tabular members 44, 46 of an adjacent T-bracket 40 or L-bracket 48 is slideably received.

[0039] Referring to FIG. 8, a key 70 can be inserted within a first channel 72 that is defined by the interior surfaces 10, 18 of the first and second flooring members 4, 6, the support T-bracket 58 that extends from the second flooring member 6, and the T-bracket 40 that extends from the first flooring member 4 in order to provide structural support and rigidity to the matting surface 2.

[0040] A key 70 can also be inserted with a second channel 73 that is defined by the interior surfaces 10, 18 of the first and second flooring members 4, 6 and adjacent T-brackets 40. The key 70 has a first end 74, a second end 76, a top surface 78, and a bottom surface 80. In one embodiment, the distance between the first end 74 and the second end 76 of the key is about 4.83 cm (1.9 in). In another embodiment, the distance between the top surface 78 and the bottom surface 80 is about 0.318 cm (0.125 in). The length of the key 70 is about 30.48 cm (12 in). The key 70 may also have one or more apertures (not shown) that extend through the top and bottom surfaces 78, 80 thereby enabling the individual inserting or removing the key 70 from the first channel 72 and/or the second channel 73 to more easily grasp the key 70.

[0041] FIG. 9 depicts another embodiment of the second flooring member 6. As can be seen from this figure, the second end 22 of the second flooring member 6 is substantially curved thereby facilitating the insertion of the substantially vertically extending tabular member 32 of one second flooring member 6 into the groove 34 of an adjacent second flooring member 36.

[0042] FIG. 10 depicts another embodiment of the second flooring member 6. As can be seen from this figure, the groove 34 at the first end 20 is defined by a first wall 82, a second wall 84, and a third wall 86. In this particular embodiment, the first and third walls 82, 86 extend substan-

tially vertically while the second wall **84** extends substantially horizontally. In the embodiment depicted in **FIG. 10**, the second edge **88** of the third wall **86** is substantially curved. In one embodiment, the distance between the outer radius and the inner radius of the curved second edge **88** is about 1.02 cm (0.4 in).

[0043] In one embodiment, the first and second flooring members **4**, **6** are manufactured from an aluminum alloy selected from a group comprising of the Aluminum Associations' 2XXX, 6XXX, and 7XXX series of aluminum alloys. More specifically, the first and second flooring members **4**, **6** are manufactured from the Aluminum Association's 2099, 2219, 2519, 6005, 6013, 6063, 6061, 7005, 7050, and 7075 aluminum alloys.

[0044] In another embodiment, the first and second flooring member **4**, **6** are manufactured from a composite or an extruded vinyl resin.

[0045] In another embodiment, the T-brackets **40**, the L-brackets **48** are attached to the interior surfaces **10**, **18** of the first and second flooring members **4**, **6** by a weld or a mechanical fastener. In another, the T- and L-brackets **40**, **48** are integrally extruded with the first and/or second flooring members **4**, **6**.

[0046] In yet another embodiment, the substantially laterally extending tabular member **24** is attached to the first flooring member **4** by a weld or a mechanical fastener. In another embodiment, the substantially laterally extending tabular member is integrally extruded with the first flooring member **4**.

[0047] In another embodiment, the substantially vertically extending tabular member **32** is attached to the second flooring member **6** by a weld or a mechanical fastener. In another embodiment, the substantially vertically extending tabular member is integrally extruded with the second flooring member **6**.

[0048] In one embodiment, the T-brackets **40** and the L-brackets **48** are attached to the interior surface **96** of the end cap **90** by a weld or a mechanical fastener. In another embodiment, the T- and L-brackets **40**, **48** are integrally extruded with the end cap **90**.

[0049] In another embodiment, the interlocked first and second flooring members **4** and **6** would have a height (H in **FIG. 1**) ranging from about 2.54 cm (1 in) to about 12.7 cm (5 in) and a total length (L3 of **FIG. 6**) ranging from about 12.7 cm (5 in) to about 254 cm (100 in). In yet another embodiment, the height (H in **FIG. 1**) of the matting surface **2** can extend up to about 25.4 cm (10 in) while the width (W1 and W2 in **FIG. 5**) of the first and second flooring members **4**, **6** can extend up to about 1,828.8 cm (60 ft). It is noted, however, that the first and second flooring members **4**, **6** can also be interlocked using other methods that include, but shall not be limited to, welding, bonding, and the use of fasteners. Using such methods would create a subsystem consisting of an interlocked first and second flooring member **4**, **6** that can be interconnected with adjacent first and second flooring members **28**, **36**.

[0050] The matting surface that is described in this invention is applicable to a number of applications. For instance, the matting surface can be used to replace existing decks, floors, docks, piers, ramps, mobile roadways, helipads, wall panels, or concrete forms.

[0051] With regards to patios, sidewalks, roadways, driveways, and shed flooring one benefit that this matting surface provides is that the matting surface would not require the extensive site preparation that is typically associated with installing such items. For example, when installing a new sidewalk or patio the homeowner would only have to do minimal soil preparation before installing the improved matting surface. Additionally, rutting of the improved matting surface is significantly reduced because of the offset orientation between the first and second flooring members and the support brackets.

[0052] Furthermore, the matting surface that is described in this invention can also be used in commercial transportation flooring such as flat-bed trailer decks. For example, this matting surface can be directly installed over the two main chassis rails of the trailer thereby eliminating the need for the longitudinal aluminum extrusions and the supporting cross-members. Through the elimination of these components, the total height of the flat-bed trailer deck will be significantly reduced and the total height of the load that is being carried on the flat-bed trailer will also be reduced. Additionally, by eliminating the longitudinal aluminum extrusions and the supporting cross-members the total cost and weight of the flat-bed trailer will be reduced.

[0053] While specific embodiments of the invention have been described in detail, it will be appreciated by those skilled in the art that various modifications and alternatives to those details could be developed in light of the overall teachings of the disclosure. Therefore, the teachings of the present invention are not limited by the number of these components shown in the exemplary **FIGS. 1-10**. Accordingly, the particular arrangements disclosed are meant to be illustrative only and not limiting as to the scope of the invention which is to be given the full breadth of the claims appended and any and all equivalents thereof.

What is claimed is:

1. A matting surface comprising:

a first flooring member;

a second flooring member;

said first flooring member being substantially parallel to said second flooring member;

said first flooring member having an extending tabular member on a first end and a groove on a second end, said groove is structured to slideably receive said tabular member of an adjacent first flooring member thereby interconnecting and forming a joint between said first flooring member and said adjacent first flooring member;

said second flooring member having an extending tabular member on a second end and a groove on a first end, said groove is structured to slideably receive said tabular member of an adjacent second flooring member thereby interconnecting and forming a joint between said second flooring member and said adjacent second flooring member;

each of said first and second flooring members having means for connecting and interlocking said first flooring member to said second flooring member; and

each of said first and second flooring members having means for supporting said joints.

2. The matting surface according to claim 1 wherein said first flooring member is offset from said second flooring member.

3. The matting surface according to claim 2 wherein said means for supporting said joint comprises:

said first flooring member having one or more support T-brackets attached to and extending from an interior surface, said support T-brackets having a top, said top located adjacent to and in contact with a surface of said joint that interconnects said second flooring member and said adjacent second flooring member; and

said second flooring member having one or more support T-brackets attached to and extending from an interior surface, said support T-brackets having a top, said top located adjacent to and in contact with a surface of said joint that interconnects said first flooring member and said adjacent first flooring member.

4. The matting surface according to claim 3 wherein said means for connecting and interlocking said first flooring member and said second flooring member comprises of one or more T-brackets attached to and extending substantially perpendicularly from said interior surface of said first flooring member and said second flooring member, said T-brackets having a top, one or more L-brackets attached to and extending from said interior surface, said L-brackets extending substantially perpendicularly from said interior surface.

5. The matting surface according to claim 4 wherein said top of said T-brackets and said support T-brackets have a first laterally extending tabular member and a second laterally extending tabular member, said T-brackets and said support T-brackets extending substantially perpendicularly from said interior surface of said first flooring member and said second flooring member so that said first and second tabular members are parallel to but not in contact with said interior surface from which said T-brackets and said support T-brackets extend.

6. The matting surface according to claim 4 wherein:

said L-brackets that are attached to and extend from said first flooring member have a top, said top having a first laterally extending tabular member, said L-brackets extending substantially perpendicularly from said interior surface of said first flooring member so that said first extending tabular member is parallel to but not in contact with said interior surface thereby forming a groove between said first extending tabular member and said interior surface, said groove slideably receives said second tabular member of said T-brackets that extend from said second flooring member and said adjacent second flooring member thereby interlocking said first flooring member to said second flooring member and to said adjacent second flooring member; and

said L-brackets that are attached to and extend from said second flooring member have a top, said top having a second laterally extending tabular member, said L-brackets extending substantially perpendicularly from said interior surface of said second flooring member so that said second extending tabular member is parallel but not in contact with said interior surface of said second flooring member thereby forming a groove

between said second extending tabular member and said interior surface of said second flooring member, said groove slideably receives said first tabular member of said T-brackets that extend from said first flooring member and said adjacent first flooring member thereby interlocking said second flooring member to said first flooring member and to said adjacent first flooring member.

7. The matting surface according to claim 1 wherein

said means for connecting and interlocking said first flooring member and said second flooring member is a tabular member extending from said interior surface of said first and second flooring members and having one or more substantially laterally extending tabular members; and

said means for connecting and interlocking said first flooring member and said second flooring member is selected from the group consisting essentially of E-, F-, H-, I-, N-, M-, W-, and Z-shaped brackets, said brackets extend from said interior surface of said first flooring member and said second flooring member.

8. The matting surface according to claim 7 wherein:

said means for connecting and interlocking said first flooring member and said second flooring member extends from each of said first and second flooring members at an angle about 90°.

9. The matting surface according to claim 7 wherein:

said means for connecting and interlocking said first flooring member and said second flooring member extends from each of said first and second flooring members at an angle greater than about 90°.

10. The matting surface according to claim 7 wherein:

said means for connecting and interlocking said first flooring member and said second flooring member extends from each of said first and second flooring members at an angle less than about 90°.

11. The matting surface according to claim 1 wherein:

said means for supporting said joint is a tabular member extending from said interior surface of said first and second flooring members and having one or more laterally extending tabular members; and

said means for supporting said joint is selected from the group consisting essentially of E-, F-, H-, I-, N-, M-, W-, and Z-shaped brackets, said brackets extend from said interior surface of said first flooring member and said second flooring member.

12. The matting surface according to claim 1 wherein:

said extending tabular member of said first flooring member is a laterally extending tabular member; and

said extending tabular member of said second flooring member is a vertically extending tabular member.

13. The matting surface according to claim 1 wherein:

said first flooring member, said T-brackets, said support T-brackets, and said L-brackets are extruded as one piece; and

said second flooring member, said T-brackets, said support T-brackets, and said L-brackets are extruded as one piece.



14. The matting surface according to claim 6 wherein said T-brackets, said support T-brackets, and said L-brackets are of a pre-selected heights.

15. The matting surface according to claim 1 wherein said first flooring member and said second flooring member is selected from the Aluminum Association's 2XXX, 6XXX, and 7XXX series of aluminum alloys.

16. The matting surface according to claim 15 wherein said first flooring member and said second flooring member are selected from the group of aluminum alloys consisting essentially of the Aluminum Association's 2099, 2219, 2519, 6005, 6013, 6063, 6061, 7005, 7050, and 7075.

17. The matting surface according to claim 1 wherein said first flooring member and said second flooring member are manufactured from a composite.

18. A matting surface comprising:

a first flooring member;

a second flooring member;

said first flooring member being substantially parallel and offset to said second flooring member;

each of said first flooring member and said second flooring member having an exterior surface, an interior surface, a first end, and a second end;

said first end of said first flooring member having a laterally extending tabular member;

said second end of said first flooring member having a groove that is structured to slideably receive said laterally extending tabular member of an adjacent first flooring member thereby interconnecting and forming a joint between said first flooring member and said adjacent first flooring member;

said second end of said second flooring member having a vertically extending tabular member;

said first end of said second flooring member having a groove is structured to slideably receive said vertically extending tabular member of an adjacent second flooring member, thereby interconnecting and forming a joint between said second flooring member and said adjacent second flooring member;

each of said first and second flooring members having a one or more of T-brackets attached to and extending from said interior surface, said T-brackets having a top, said top having a first laterally extending tabular member and a second laterally extending tabular member, said T-brackets extending substantially perpendicularly from said interior surface of said first flooring member so that said first and second tabular members are parallel to but not in contact with said interior surface from which said T-brackets extend;

said first flooring member having a one or more of L-brackets attached to and extending from said interior surface, said L-brackets having a top, said top having a first laterally extending tabular member, said L-brackets extending substantially perpendicularly from said interior surface of said first flooring member so that said first extending tabular member is parallel to but not in contact with said interior surface thereby forming a groove between said first extending tabular member and said interior surface, said groove slideably receives

said second tabular member of said T-brackets that extend from said second flooring member and said adjacent second flooring member thereby interlocking said first flooring member to said second flooring member and to said adjacent second flooring member;

said second flooring member having a one or more of L-brackets attached to and extending from said interior surface, said L-brackets having a top, said top having a second laterally extending tabular member, said L-brackets extending substantially perpendicularly from said interior surface of said second flooring member so that said second extending tabular member is parallel to but not in contact with said interior surface of said second flooring member thereby forming a groove between said second extending tabular member and said interior surface of said second flooring member, said groove slideably receives said first tabular member of said T-brackets that extend from said first flooring member and said adjacent first flooring member thereby interlocking said second flooring member to said first flooring member and to said adjacent first flooring member;

each of said first and second flooring members having one or more support T-brackets, said support T-brackets having a top, said top having a first laterally extending tabular member and a second laterally extending tabular member, said support T-brackets extending substantially perpendicularly from said interior surface of said first flooring member so that said first and second tabular members are parallel to but not in contact with said interior surface from which said support T-brackets extend;

said first and second laterally extending tabular members of said support T-brackets that are attached to and extend from said first flooring member are located adjacent to and in contact with a surface of said joint that interconnects said second flooring member and said adjacent second flooring member; and

said first and second laterally extending tabular members of said support T-brackets that are attached to and extend from said second flooring member are located adjacent to and in contact with said joint that interconnects said first flooring member and said adjacent first flooring member.

19. The matting surface according to claim 18 wherein said first flooring member, said T-brackets, said support T-brackets, and said L-brackets are extruded as one piece; and

said second flooring member, said T-brackets, said support T-brackets, and said L-brackets are extruded as one piece.

20. The matting surface according to claim 18 wherein said T-brackets, said support T-brackets, and said L-brackets are of pre-selected heights.

21. The matting surface according to claim 18 wherein said first flooring member and said second flooring member are selected from a group comprising of the Aluminum Association's 2XXX, 6XXX, and 7XXX series of aluminum alloys.

22. The matting surface according to claim 18 wherein said first flooring member and said second flooring member are selected from the group of aluminum alloys consisting

essentially of the Aluminum Association's 2099, 2219, 2519, 6005, 6013, 6063, 6061, 7005, 7050, and 7075.

23. The matting surface according to claim 18 wherein said first flooring member and said second flooring member are manufactured from a composite.

24. The matting surface according to claim 18 wherein said T-brackets extend from said interior surface at an angle about 90°.

25. The matting surface according to claim 18 wherein said T-brackets extend from said interior surface at an angle greater than about 90°.

26. The matting surface according to claim 18 wherein said T-brackets extend from said interior surface at an angle less than about 90°.

27. The matting surface according to claim 18 further comprising one or more keys inserted within a first channel, said first channel is defined by said interior surfaces of said first and second flooring members, said support T-brackets extending from said second flooring member, and said T-brackets extending from said first flooring member.

28. The matting surface according to claim 18 further comprising one or more keys inserted with a second channel, said second channel is defined by said interior surfaces of said first and second flooring members and said adjacent T-brackets.

29. The matting surface according to claim 18 wherein said end cap is manufactured from an aluminum alloy selected from the Aluminum Association's 2XXX, 6XXX, and 7XXX series of aluminum alloys.

30. The matting surface according to claim 18 wherein said matting surface is a deck, floor, dock, pier, ramp, mobile roadway, helipad, wall panel, or concrete form.

31. A method of making a matting surface comprising:

providing a first flooring member and a second flooring member, each of said first and second flooring members having an exterior surface, an interior surface, a first end, and a second end, said first flooring member having a laterally extending tabular member on said first end and a groove on said second end, said groove structured to slideably receive said laterally extending tabular member of an adjacent first flooring member, said second flooring member having a vertically extending tabular member on said second end and a groove on said first end, said groove structured to slideably receive said vertically extending tabular member of an adjacent second flooring member, each of said first and second flooring members having a plurality of T-brackets and L-brackets attached to and extending from said interior surface, said T-brackets and L-brackets extending perpendicularly from said interior surface of each of said first and second flooring members, each of said first and second flooring members having one or more support T-brackets that extend perpendicularly from said interior surface of said first and second flooring members;

positioning said first flooring member so that said T-brackets that extend from said first flooring member are located laterally adjacent to a groove that is formed between said L-brackets that extend from said second flooring member and said interior surface of said second flooring member and adjacent to and in contact with said interior surface of said second flooring member, and that said T-brackets that extend from said

second flooring member are located laterally adjacent to a groove that is formed between said L-brackets that extend from said first flooring member and said interior surface of said first flooring member and adjacent to and in contact with said interior surface of said first flooring member; and

interlocking said first flooring member to said second flooring member by slidingly moving said first flooring member in a lateral direction whereby said T-brackets that extend from said first flooring member are slidingly received into said groove that is formed between said L-bracket of said second flooring member and said interior surface of said second flooring member and said T-brackets that extend from said second flooring member are slidingly received into said groove formed between said L-brackets of said first flooring member and said interior surface of said first flooring member.

32. The method of making a matting surface according to claim 31 wherein prior to positioning said first flooring members, connecting a plurality of second flooring members by slidingly receiving said vertically extending tabular member of said second flooring member into said groove of an adjacent second flooring member thereby forming a joint between said second flooring member and said adjacent second flooring member.

33. The method of making a matting surface according to claim 31 wherein positioning said first flooring member so that said first flooring member is offset from said second flooring member and said support T-brackets that are attached to and extend from said first flooring member are adjacent to and in contact with a surface of said joint that interconnects said second flooring member and said adjacent second flooring member.

34. The method of making a matting surface according to claim 31 wherein connecting a plurality of first flooring members by slidingly receiving said laterally extending tabular member of said first flooring member into said groove of an adjacent first flooring member.

35. The method of making a matting surface according to claim 31 wherein providing a first flooring member and a second flooring member selected from the 2XXX, 6XXX, and 7XXX series of aluminum alloys.

36. The method of making a matting surface according to claim 31 wherein providing a first flooring member and a second flooring member selected from the group of aluminum alloys consisting essentially of the Aluminum Association's 2099, 2219, 2519, 6005, 6013, 6063, 6061, 7005, 7050, and 7075.

37. The method of making a matting surface according to claim 31 wherein providing a first flooring member and a second flooring member manufactured from a composite.

38. The method of making a matting surface according to claim 31 wherein inserting a plastic plug is between said T-brackets after interconnecting said first flooring member and said second flooring member to further interlock and to add stiffness to said interlocked first and second flooring members.

39. The method of making a matting surface according to claim 31 wherein inserting one or more keys within a first channel, said first channel is defined by said interior surfaces of said first and second flooring members, said support T-brackets extending from said second flooring member, and said T-brackets extending from said first flooring member.