



(12) **EUROPEAN PATENT APPLICATION**

(43) Date of publication:
24.06.1998 Bulletin 1998/26

(51) Int Cl. 6: **F23C 7/00, F23D 17/00**

(21) Application number: **97310464.9**

(22) Date of filing: **22.12.1997**

(84) Designated Contracting States:
**AT BE CH DE DK ES FI FR GB GR IE IT LI LU MC
NL PT SE**
Designated Extension States:
AL LT LV MK RO SI

- **Hauck, Stephen F.**
Jupiter, Florida 33458 (US)
- **Snyder, Timothy S.**
South Windsor, Connecticut 06101 (US)
- **Sowa, William A.**
Simsbury, Connecticut 06070 (US)

(30) Priority: **20.12.1996 US 770277**
20.12.1996 US 771460

(74) Representative: **Leckey, David Herbert**
Frank B. Dehn & Co.,
European Patent Attorneys,
179 Queen Victoria Street
London EC4V 4EL (GB)

(71) Applicant: **UNITED TECHNOLOGIES
CORPORATION**
Hartford, CT 06101 (US)

(72) Inventors:
• **Kramer, Stephen K.**
Stuart, Florida 34997 (US)

(54) **Fuel nozzles and centerbodies therefor**

(57) A tangential air entry fuel nozzle (10) has a combustor inlet port (20) to permit air and fuel to exit into a combustor (56). The port includes a convergent surface (116), a combustor surface, and a cylindrical surface (118) extending therebetween. The convergent surface extends a first distance along the longitudinal axis (26) of the nozzle, the cylindrical surface extends a second distance along the axis, and the second distance is at least 30% of the first distance.

surface (118) extending therebetween. The convergent surface extends a first distance along the longitudinal axis (26) of the nozzle, the cylindrical surface extends a second distance along the axis, and the second distance is at least 30% of the first distance.

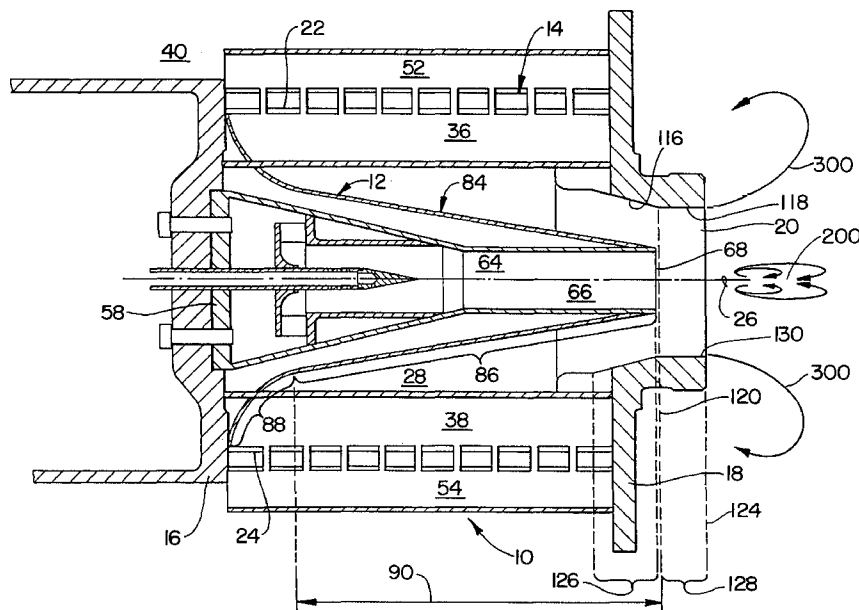

FIG. 3

EP 0 849 530 A2

Description

This invention relates to low NO_x premix fuel nozzles, and particularly to such nozzles for use in gas turbine engines.

The production of nitrous oxides (hereinafter "NO_x") occurs as a result of combustion at high temperatures. NO_x is a notorious pollutant, and as a result, combustion devices which produce NO_x are subject to ever more stringent standards for emissions of such pollutants. Accordingly, much effort is being put forth to reduce the formation of NO_x in combustion devices.

One solution has been to premix the fuel with an excess of air such that the combustion occurs with local high excess air, resulting in a relatively low combustion temperature and thereby minimizing the formation of NO_x. A fuel nozzle which so operates is shown in U.S. Pat. No. 5,307,634, which discloses a scroll swirler with a conical centerbody. This type of fuel nozzle is known as a tangential entry fuel nozzle, and comprises two offset cylindrical-arc scrolls connected to two endplates. Combustion air enters the swirler through two substantially rectangular slots formed by the offset scrolls, and exits through a combustor inlet port in one endplate and flows into the combustor. A linear array of orifices located on the outer scroll opposite the inner trailing edge injects fuel into the airflow at each inlet slot from a manifold to produce a uniform fuel air mixture before exiting into the combustor.

Premix fuel nozzles of the tangential entry type have demonstrated low emissions of NO_x relative to fuel nozzles of the prior art. Unfortunately, fuel nozzles such as the one disclosed in the aforementioned patent have exhibited an unacceptably short operational life when used in gas turbine engines, due in part to attachment of flames to the nozzle centerbody. As a result, tangential entry fuel nozzles of this type have not been incorporated into commercially available gas turbine engines.

What is needed is a tangential entry fuel nozzle that significantly increases the operational life thereof over the prior art when used in gas turbine engines.

Accordingly, a centerbody disclosed herein comprises a longitudinal axis and a radially outer surface including a frustum portion defining the outer surface of a frustum that is coaxial with the longitudinal axis and flares toward the frustum base thereof, and a curved portion which is integral with the frustum portion and preferably defines a portion of the surface generated by rotating a circle which is tangent to the frustum portion and has a center which lies radially outward thereof about the longitudinal axis. The centerbody has a base which includes at least one air supply port extending therethrough, and an internal passageway. The frustum portion tapers towards a discharge orifice of the internal passageway, and terminates at the plane in which the discharge orifice is located. A fuel-lance that is coaxial with the axis and extends through the base and termi-

nates within the internal passageway provides fuel to the air flow in the centerbody.

A tangential air entry fuel nozzle disclosed herein has a longitudinal axis and two cylindrical-arc scrolls with the centerline of each offset from that of the other. Overlapping ends of these scrolls form an air inlet slot therebetween for the introduction of an air/fuel mixture into the fuel nozzle. A combustor-end endplate has a combustor inlet port to permit air and fuel to exit the nozzle into a combustor. The port includes a convergent surface, a divergent surface, and a cylindrical surface extending therebetween. The convergent surface extends a first distance along the longitudinal axis of the nozzle, the cylindrical surface extends a second distance along the axis, and the second distance is preferably at least 5% of the first distance. Opposite the combustor-end endplate another endplate blocks the nozzle flow area, and the scrolls are secured between these endplates.

A centerbody located between the scrolls and coaxial with the axis has a radially outer surface including a frustum portion defining the outer surface of a frustum that is coaxial with the longitudinal axis and a cylindrical portion that is coaxial with the longitudinal axis and defines the outer surface of a cylinder. The centerbody has a base which includes at least one air supply port extending therethrough, and an internal passageway. The frustum portion tapers towards a discharge orifice of the internal passageway, and the cylindrical portion is located between the frustum portion and the plane in which the discharge orifice is located. A fuel-lance that is coaxial with the axis and extends through the base and terminates within the internal passageway provides fuel to the air flow in the centerbody.

Some preferred embodiments of the present invention will now be described, by way of example only, with reference to the accompanying drawings in which:

Figure 1 is a cross-sectional view of a fuel nozzle of the present invention, taken along line 1-1 of Figure 2.

Figure 2 is a cross-sectional view looking down the longitudinal axis of the nozzle of the present invention.

Figure 3 is a cross-sectional view of the fuel nozzle of the present invention, taken along line 3-3 of Figure 2.

Figure 4 is a longitudinal cross-sectional view of a centerbody embodying the present invention.

Figure 5 is a cross-sectional view taken along line 5-5 of Figure 4.

Figure 6 is a longitudinal cross-sectional view of the centerbody of the present invention taken along line 6-6 of Figure 5.

Referring to Figure 1, a low NO_x premix fuel nozzle 10 embodying the present invention includes a centerbody 12 within a scroll swirler 14. The scroll swirler 14 includes first and second endplates 16, 18, and the first endplate is connected to the centerbody 12 and is in spaced relation to the second endplate 18, which has a combustor inlet port 20 extending therethrough. A plurality, and preferably two, cylindrical-arc scroll members

22, 24 extend from the first endplate 16 to the second endplate 18.

The scroll members 22, 24 are spaced uniformly about the longitudinal axis 26 of the nozzle 10 thereby defining a mixing zone 28 therebetween, as shown in Figure 2. Each scroll member 22, 24 has a radially inner surface which faces the longitudinal axis 26 and defines a surface of partial revolution about a centerline 32, 34. As used herein, the term "surface of partial revolution" means a surface generated by rotating a line less than one complete revolution about one of the centerlines 32, 34.

Each scroll member 22 is in spaced relation to the other scroll member 24, and the centerline 32, 34 of each of the scroll members 22, 24 is located within the mixing zone 28, as shown in Figure 2. Referring to Figure 3, each of the centerlines 32, 34 is parallel, and in spaced relation, to the longitudinal axis 26, and all of the centerlines 32, 34 are located equidistant from the longitudinal axis 26, thereby defining inlet slots 36, 38 extending parallel to the longitudinal axis 26 between each pair of adjacent scroll members 22, 24 for introducing combustion air 40 into the mixing zone 28. Combustion supporting air 42 from the compressor (not shown) passes through the inlet slots 36, 38 formed by the overlapping ends 44, 50, 48, 46 of the scroll members 22, 24 with offset centerlines 32, 34.

Each of the scroll members 22, 24 further includes a fuel conduit 52, 54 for introducing fuel into the combustion air 40 as it is introduced into the mixing zone 28 through one of the inlet slots 36, 38. A first fuel supply line (not shown), which may supply either a liquid or gas fuel, but preferably gas, is connected to the each of the fuel conduits 52, 54. The combustor inlet port 20, which is coaxial with the longitudinal axis 26, is located immediately adjacent the combustor 56 to discharge the fuel and combustion air from the present invention into the combustor 56, where combustion of the fuel and air takes place.

Referring back to Figure 1 and to Figure 4, the centerbody 12 has a base 58 that has at least one, and preferably a plurality, of air supply ports 60, 62 extending therethrough, and the base 58 is perpendicular to the longitudinal axis 26 extending therethrough. The centerbody 12 also has an internal passageway 64 that is coaxial with the longitudinal axis 26. In the preferred embodiment of the invention, the internal passageway 64 includes a first cylindrical passage 66 having a first end 68 and a second end 70, and a second cylindrical passage 72 of greater diameter than the first cylindrical passage 66 and likewise having a first end 74 and a second end 76. The second cylindrical passage 72 communicates with the first cylindrical passage 66 through a tapered passage 78 having a first end 80 that has a diameter equal to the diameter of the first cylindrical passage 66, and a second end 82 that has a diameter equal to the diameter of the second cylindrical passage 72. Each of the passages 66, 72, 78 is coaxial with the longitudinal

axis 26, and the first end-80 of the tapered passage 78 is integral with the second end 70 of the first cylindrical passage 66, while the second end 82 of the tapered passage 78 is integral with the first end 74 of the second cylindrical passage 72. The first cylindrical passage 66 includes a discharge orifice 68 that is circular and coaxial with the longitudinal axis 26, and is located at the first end 68 of the first cylindrical passage 66.

Referring to Figures 3 and 6, the radially outer surface 84 of the centerbody 12 includes a frustum portion 86, which defines the outer surface of a frustum that is coaxial with the longitudinal axis 26 and flares toward the base 58, and a curved portion 88 which is integral with the frustum portion 86 and preferably defines a portion of the surface generated by rotating a circle, which is tangent to the frustum portion 86 and has a center which lies radially outward thereof, about the longitudinal axis 26. In the preferred embodiment, the frustum portion 86 terminates at the plane within which the discharge orifice 68 is located, the diameter of the base (not to be confused with the base 58 of the centerbody) of the frustum portion 86 is 2.65 times greater than the diameter of the frustum portion 86 at the apex thereof, and the height 90 of the frustum portion 86 (the distance between the plane in which the base of the frustum portion 86 is located and the plane in which the apex of the frustum portion 86 is located) is approximately 1.90 times the diameter of the frustum portion 86 at the base thereof. As described in further detail below, the curved portion 88, which is located between the base 58 and the frustum portion 86, provides a smooth transitional surface that directs combustion air 40 entering the tangential entry nozzle 10 adjacent the base 58. As shown in Figure 3, the internal passageway 64 is located radially inward from the radially outer surface 84 of the centerbody 12, the frustum portion 86 is coaxial with the longitudinal axis 26, and the centerbody 12 is connected to the base 58 such that the frustum portion 86 tapers toward, and terminates at the discharge orifice 68 of the first cylindrical passage 66.

As shown in Figure 2, the base of the frustum portion 86 fits within a circle 92 inscribed in the mixing zone 28 and having its center 94 on the longitudinal axis 26. As those skilled in the art will readily appreciate, since the mixing zone 28 is not circular in cross section, the curved portion 88 must be cut to fit therein. A ramp portion 96, 98 is left on the curved portion 88 where the curved portion 88 extends into each inlet slot 36, 38, and this portion is machined to form an aerodynamically shaped ramp 96, 98 that directs the air entering the inlet slot 36, 38 away from the base 58 and onto the curved portion 88 within the mixing zone 28.

Referring to Figure 1, an internal chamber 100 is located within the centerbody 12 between the base 58 and the second end 76 of the second cylindrical passage 72, which terminates at the chamber 100. Air 102 is supplied to the chamber 100 through the air supply ports 60, 62 in the base 58 which communicate there-

with, and the chamber 100, in turn, supplies air to the internal passageway 64 through the second end 76 of the second cylindrical passage 72. The first endplate 16 has openings 104, 106 therein that are aligned with the air supply ports 60, 62 of the base 58 so as not to interfere with the flow of combustion air 102 from the compressor of the gas turbine engine. A swirler 108, preferably of the radial inflow type known in the art, is coaxial with the longitudinal axis 26 and is located within the chamber 100 immediately adjacent the second end 76 of the second cylindrical passage 72 such that all air entering the internal passageway 64 from the chamber 100 must pass through the swirler 108.

A fuel lance 110, which likewise is coaxial with the longitudinal axis 26, extends through the base 58, the chamber 100, and the swirler 108, and into the second cylindrical passage 72 of the internal passageway 64. The larger diameter of the second cylindrical passage 72 accommodates the cross-sectional area of the fuel lance 110, so that the flow area within the second cylindrical passage 72 is essentially equal to the flow area of the first cylindrical passage 66. A second fuel supply line (not shown), which may supply either a liquid or gas fuel, is connected to the fuel lance 110 to supply fuel to an inner passage 112 within the fuel lance 110. Fuel jets 114 are located in the fuel lance 110, and provide a pathway for fuel to exit from the fuel lance 110 into the internal passageway 64.

Referring to Figure 3, the combustor inlet port 20 is coaxial with the longitudinal axis 26 and includes a convergent surface 116 and a cylindrical surface 118 that defines the throat of the inlet port. The convergent surface 116 and the cylindrical surface 118 are likewise coaxial with the longitudinal axis 26, and the convergent surface 116 is located between the first endplate 16 and the cylindrical surface 118. The convergent surface 116 is substantially conical in shape and tapers toward the cylindrical surface 118. The cylindrical surface 118 extends between the throat plane 120 and the combustor surface 122 of the combustor port inlet 20, which is perpendicular to the longitudinal axis 26, and defines the exit plane 124 of the fuel nozzle 10 of the present invention. To achieve the desired axial velocity of the fuel/air mixture through the combustor inlet port 20, the combustion air flowing therethrough must encounter the minimum flow area, or throat area, at the combustor inlet port 20. To achieve this result, the cylindrical surface 118 is located at a predetermined radius from the longitudinal axis 26 that is at least 10% less than the radius of the base of the frustum portion 86.

The convergent surface 116 terminates at the throat plane 120, where the diameter of the convergent surface 116 is equal to the diameter of the cylindrical surface 118. As shown in Figure 3, the throat plane 120 is located between the exit plane 124 and the discharge orifice 68 of the internal passageway 64, and the convergent surface 116 is located between the cylindrical surface 118 and the first endplate 16. In order to estab-

lish the desired velocity profile of the fuel/air mixture within the combustor inlet port 20, the convergent surface 116 extends a predetermined distance 126 along the longitudinal axis 26 and the cylindrical surface 118 extends a second distance 128 along the longitudinal axis 26 that is at least 30% of the predetermined distance 126.

In operation, combustion air from the compressor of the gas turbine engine flows through the openings 104, 106 and the air supply ports 60, 62 in the base 58 and into the chamber 100 of the centerbody 12. The combustion air exits the chamber 100 through the radial inflow swirler 108 and enters the internal passageway 64 with a substantial tangential velocity, or swirl, relative to the longitudinal axis 26. When this swirling combustion air passes the fuel lance 110, fuel, preferably in gaseous form, is sprayed from the fuel lance 110 into the internal passage 64 and mixes with the swirling combustion air. The mixture of fuel and combustion air then flows from the second cylindrical passage 72 into the first cylindrical passage 66 through the tapered passage 78. The mixture then proceeds down the length of the first cylindrical passage 66, exiting the first cylindrical passage 66 just short of, or at, the throat plane 120 of the combustor inlet port 20, providing a central stream of fuel air mixture.

Additional combustion air from the compressor of the gas turbine engine enters the mixing zone 28 through each of the inlet slots 36, 38. Air entering the inlet slots 36, 38 immediately adjacent the base 58 is directed by the ramps 96, 98 onto the curved portion 88 within the mixing zone 28 of the scroll swirler 14. Fuel, preferably gaseous fuel, supplied to the fuel conduits 52, 54 is sprayed into the combustion air passing through the inlet slots 36, 38 and begins mixing therewith. Due to the shape of the scroll members 22, 24, this mixture establishes an annular stream swirling about the centerbody 12, and the fuel/air mixture continues to mix as it swirls thereabout while progressing along the longitudinal axis 26 toward the combustor inlet port 20.

The swirl of the annular stream produced by the scroll swirler 14 is preferably co-rotational with the swirl of the fuel/air mixture in the first cylindrical passage 66, and preferably has an angular velocity at least as great as the angular velocity of the fuel/air mixture in the first cylindrical passage 66. Due to the shape of the centerbody 12, the axial velocity of the annular stream is maintained at speeds which prevent the combustor flame from migrating into the scroll swirler 14 and attaching to the outer surface 84 of the centerbody 12. Upon exiting the first cylindrical passage 66, the swirling fuel/air mixture of the central stream is surrounded by the annular stream of the scroll swirler 14, and the two streams enter the throat 120 of the combustor inlet port 20 and flow radially inward of the cylindrical surface 118 until reaching the exit plane 124 of the combustion inlet port 20 downstream of the mixing zone 28.

Upon exiting the combustor inlet port 20, the inter-

action of the central stream with the annular stream creates a central recirculation zone 200 which is downstream from the exit plane 124 (i.e. the exit plane lies between the central recirculation zone and the discharge orifice of the internal passageway) and in spaced relation thereto. The sharp lip 130 formed where the cylindrical surface 118 meets the combustor surface 122 of the combustor inlet port 20 causes sudden expansion of the fuel/air mixture and recirculation of the fuel/air mixture radially outward of the central recirculation zone 200. The combustion and flame produced in this outer recirculation 300 anchors this "outer" flame adjacent the lip 130, but the flame is in spaced relation to the exit plane 124 and entirely downstream thereof. As a result of the design of the present invention, both recirculation zones 200, 300 are maintained in spaced relation to the exit plane 124 at all engine operating conditions.

The fuel nozzle 10 described substantially reduces the flow oscillations and attendant heat release rates resulting therefrom, which caused excessive combustor pressure fluctuations and an acoustic tone. The present invention eliminates the aforementioned interaction between the combustion process and the exit plane 124, resulting in significantly lower acoustic fluctuations. Consequently, the present invention provides a solution to the problem of excessive pressure fluctuations in the tangential entry fuel nozzle 10 while achieving the low emissions performance thereof.

Furthermore, testing on the centerbody 10 has demonstrated that the centerbody 10 has a significantly increased operational life as compared to the prior art when used in gas turbine engines by reducing the tendency of flames to attach to the centerbody 10. Consequently, the present invention also provides a solution to the problem that has prevented widespread use of tangential entry nozzles in gas turbine engines.

It will thus be seen that in its preferred embodiments at least, the invention provides a low NOx fuel nozzle which significantly increases the operational life thereof over the prior art when used in gas turbine engines and a tangential entry fuel nozzle that significantly reduces the tendency of flames to attach to the centerbody thereof while maintaining acceptably low levels of NOx production.

Although this invention has been shown and described with respect to a detailed embodiment thereof, it will be understood by those skilled in the art that various changes in form and detail thereof may be made without departing from the scope of the claimed invention. For example, the centerbody may be used with other scroll swirler constructions, for example one in which instead of having a cylindrical surface 118, the combustor inlet port 20 may comprise a divergent surface 118 connecting the convergent surface to the combustion surface 122.

Claims

1. A centerbody (12) for a tangential entry fuel nozzle, comprising:

a longitudinal axis (26),
 a centerbody base (58) having at least one air supply port (60,62) extending therethrough,
 a radially outer surface (84) including a frustum portion (86) defining the outer surface of a frustum that is coaxial with the longitudinal axis and flares toward the frustum base thereof; and a curved portion (88) which is integral with the frustum portion,

an internal passageway (64) coaxial with the longitudinal axis and including a first cylindrical passage (66), a second cylindrical passage (72), and a tapered passage (78), each passage having a first end (68, 74, 80) and a second end (70, 76, 82), said second cylindrical passage having a diameter greater than said first cylindrical passage, said second cylindrical passage communicating with said first cylindrical passage through said tapered passage, said first end of said tapered passage integral with said second end of said first cylindrical passage, said second end of said tapered passage integral with said first end of said second cylindrical passage, said first end of said tapered passage having a diameter equal to the diameter of the first cylindrical passage, and said second end of said tapered passage having a diameter equal to the diameter of the second cylindrical passage, each of said passages coaxial with the longitudinal axis, said first cylindrical passage includes a discharge orifice (68) that is circular, coaxial with said axis and located at the first end of said first cylindrical passage,

an internal chamber (100) located between said centerbody base and said second end of said second cylindrical passage, said air supply ports communicating with said second cylindrical passage through said chamber,

a swirler (108) coaxial with the axis and located within the chamber immediately adjacent the second end of the second cylindrical passage, and

a fuel lance (110) coaxial with said axis and extending through said centerbody base, said internal chamber, and said swirler, and terminating within said second cylindrical passage.

2. The centerbody (12) of claim 1 wherein said curved portion (88) defines a portion of the surface generated by rotating a circle which is tangent to the frustum portion (86) and has a center which lies radially outward thereof about the longitudinal axis (26).

3. A fuel nozzle assembly comprising a centerbody (12) as claimed in claim 1 or 2.

4. A fuel nozzle assembly for use a gas turbine engine, comprising:
a centerbody (12) including a longitudinal axis (26),

a radially outer surface (84) including a frustum portion (86) defining the outer surface of a frustum that is coaxial with the longitudinal axis and flares toward the frustum base thereof, and a curved portion (88) which is integral with the frustum portion,

a centerbody base (58), said centerbody base having at least one air supply port (60, 62) extending therethrough,

an internal passageway (64) coaxial with the longitudinal axis and including a first cylindrical passage (66), a second cylindrical passage (72), and a tapered passage (78), each passage having a first end (68, 74, 80) and a second end (70, 76, 82), said second cylindrical passage having a diameter greater than said first cylindrical passage, said second cylindrical passage communicating with said first cylindrical passage through said tapered passage, said first end of said tapered passage integral with said second end of said first cylindrical passage, said second end of said tapered passage integral with said first end of said second cylindrical passage, said first end of said tapered passage having a diameter equal to the diameter of the first cylindrical passage, and said second end of said tapered passage having a diameter equal to the diameter of the second cylindrical passage, each of said passages coaxial with the longitudinal axis, said first cylindrical passage includes a discharge orifice (68) that is circular, coaxial with said axis and located at the first end of said first cylindrical passage,

an internal chamber (100) located between said centerbody base and said second end of said second cylindrical passage, said air supply ports communicating with said second cylindrical passage through said chamber, a swirler (108) coaxial with the axis and located within the chamber immediately adjacent the second end of the second cylindrical passage, a fuel lance (110) coaxial with said axis and extending through said centerbody base, said internal chamber, and said swirler, and terminating within said second cylindrical passage; and a scroll swirler (14) having first and second endplates (16,18), said first endplate in spaced relation to said second endplate, said second endplate having a combustor inlet port (20) extending therethrough, said

inlet port coaxial with said axis and including a convergent surface (116), an combustor surface (122), and a cylindrical surface (118) extending from said convergent surface to said combustor surface,

at least two cylindrical-arc scroll members (22, 24), each scroll member defining a body of partial revolution about a centerline (32, 34), each of said scroll members extending from said first endplate to said second endplate and spaced uniformly about the axis thereby defining a mixing zone (28) therebetween, each of said scroll members in spaced relation to each of the other scroll members, each of said centerlines located within said mixing zone, each of said centerlines in spaced relation to, equidistant from, and parallel to said axis, thereby defining inlet slots (36, 38) extending parallel to said axis between each pair of adjacent scroll members for introducing combustion air into said mixing zone, each of said scroll members including a fuel conduit (52, 54) for introducing fuel into combustion air introduced through one of said inlet slots;

wherein said first endplate is connected to said centrebody base.

5. The fuel nozzle assembly of claim 4 wherein said curved portion (88) defines a portion of the surface generated by rotating a circle which is tangent to the frustum portion (86) and has a center which lies radially outward thereof about the longitudinal axis (26).

6. The fuel nozzle assembly of claim 4 or 5 wherein said convergent surface (116) extends a first distance (126) along said axis (26), said cylindrical surface (118) extends a second distance (128) along said axis, and said second distance is at least 30% of the first distance.

7. The fuel nozzle assembly of claim 4, 5 or 6 wherein said combustor surface (116) is perpendicular to said axis (26).

8. The fuel nozzle assembly of claim 4, 5, 6 or 7 wherein the cylindrical surface (118) is located at a predetermined radius from the axis (26) that is at least 10% less than the radius of the frustum portion (86) at the base thereof.

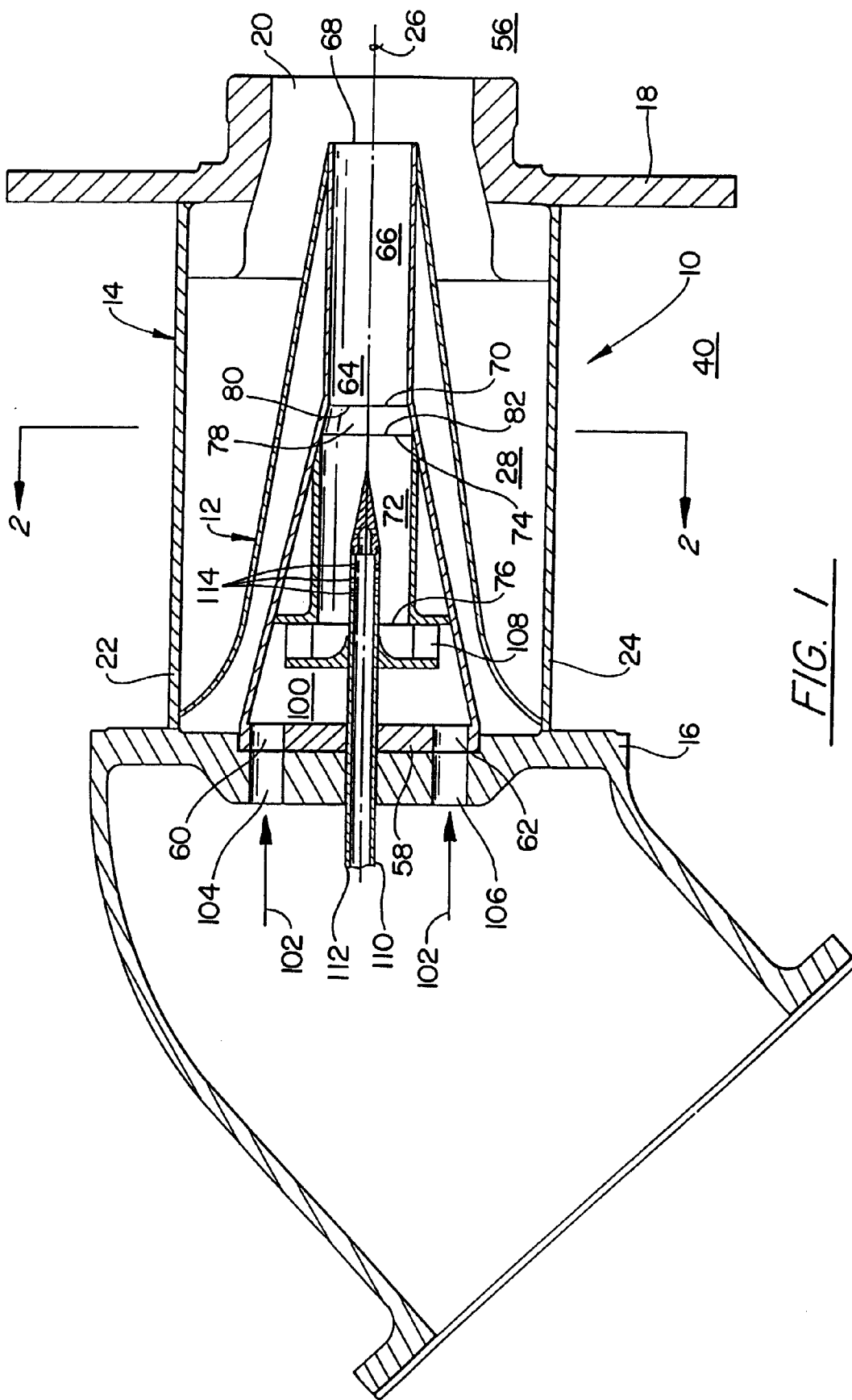

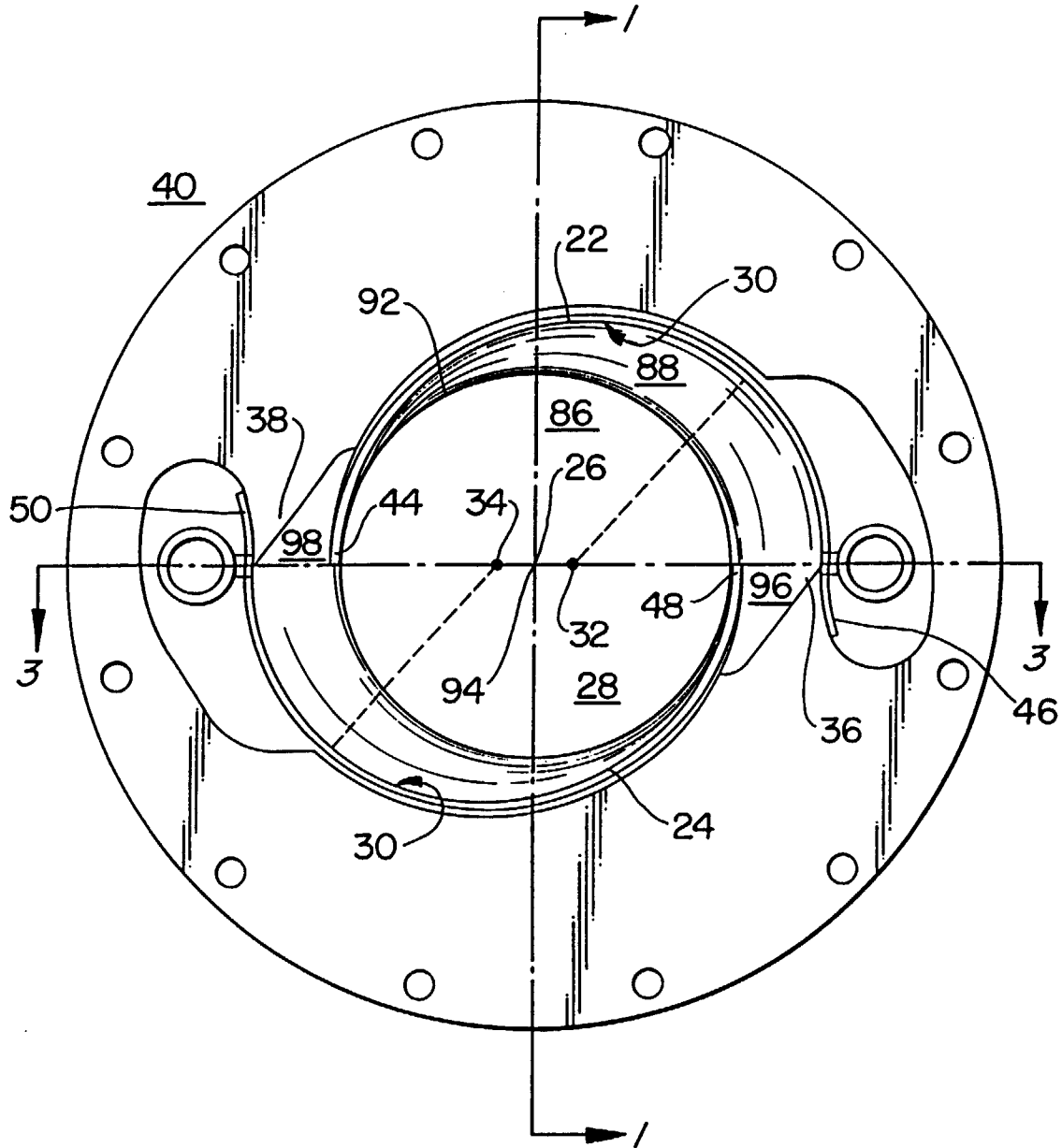

FIG. 2

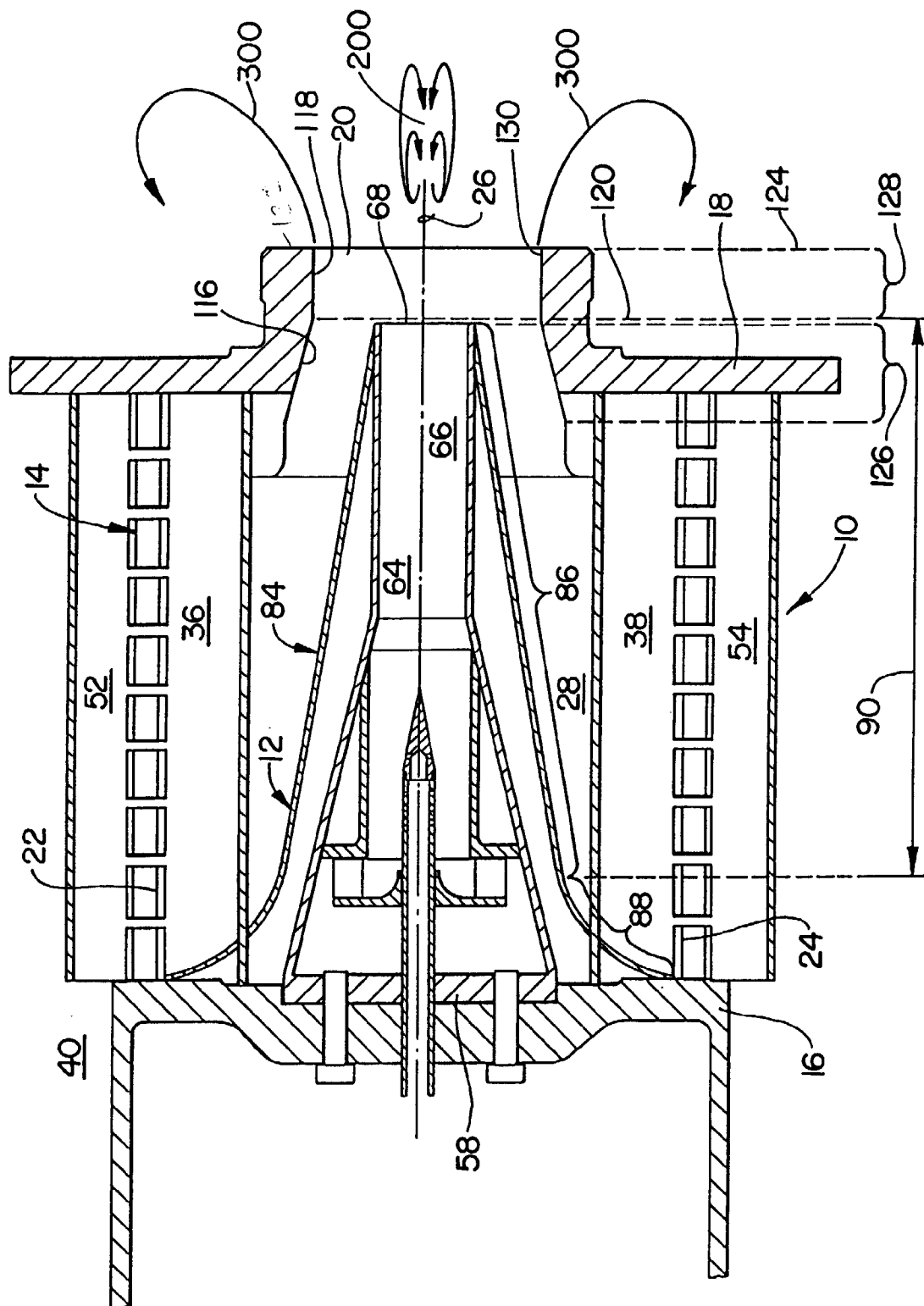

FIG. 3

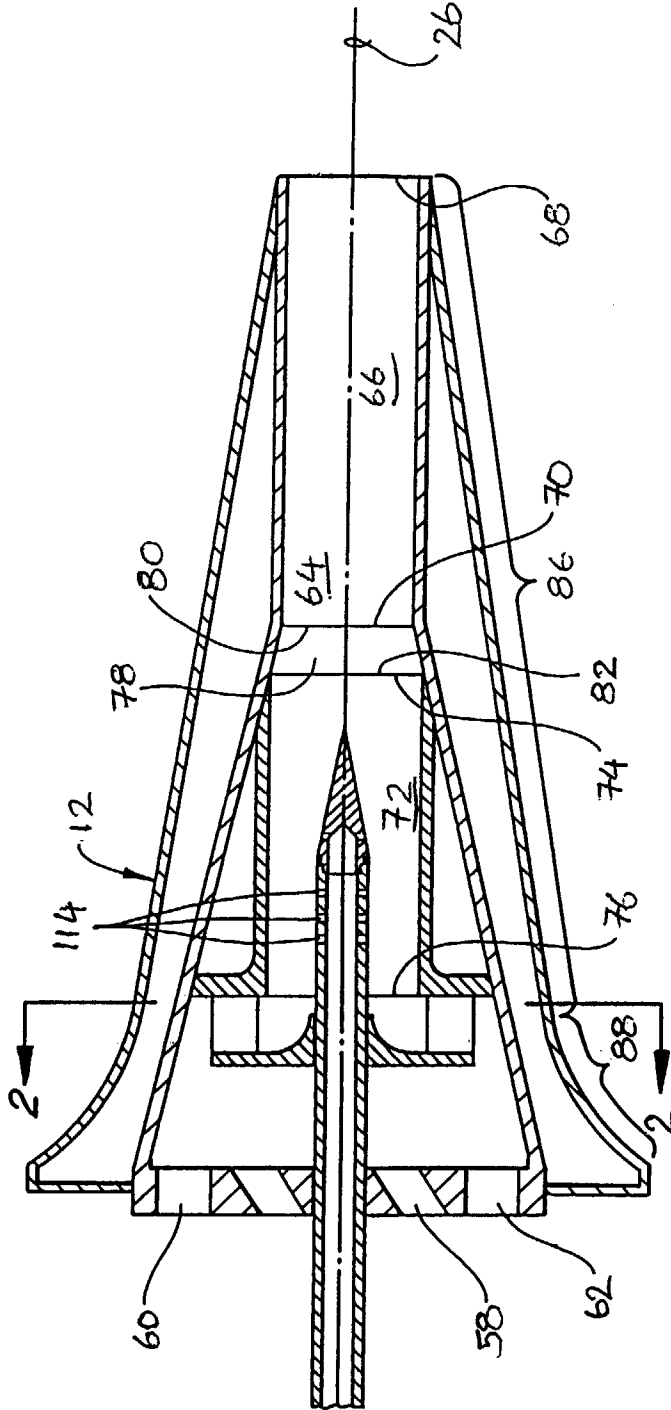

FIG. 4

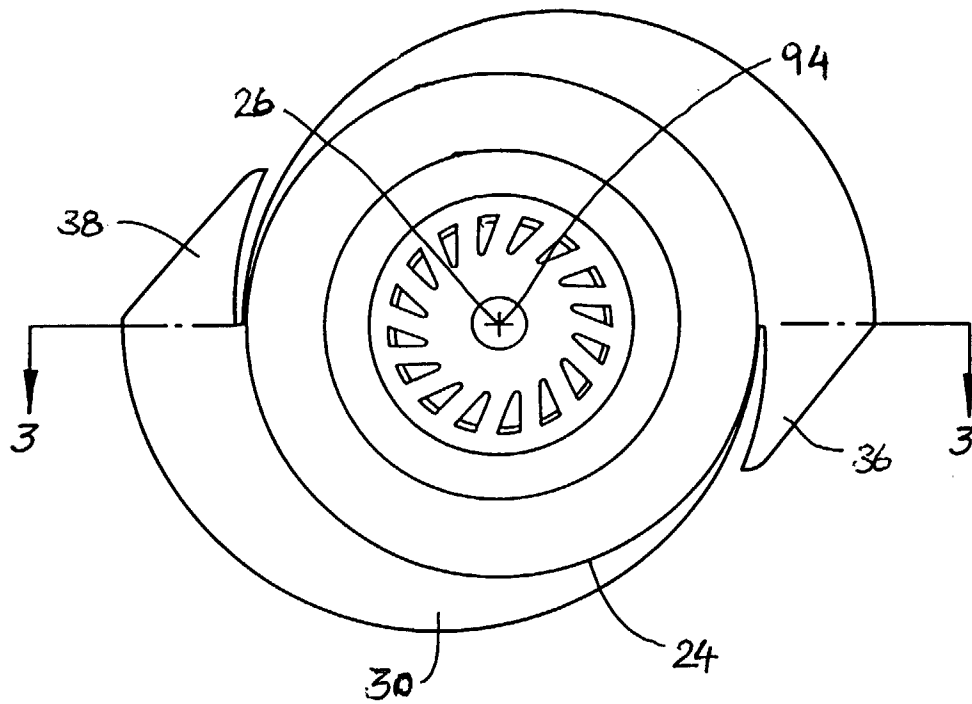

FIG. 5

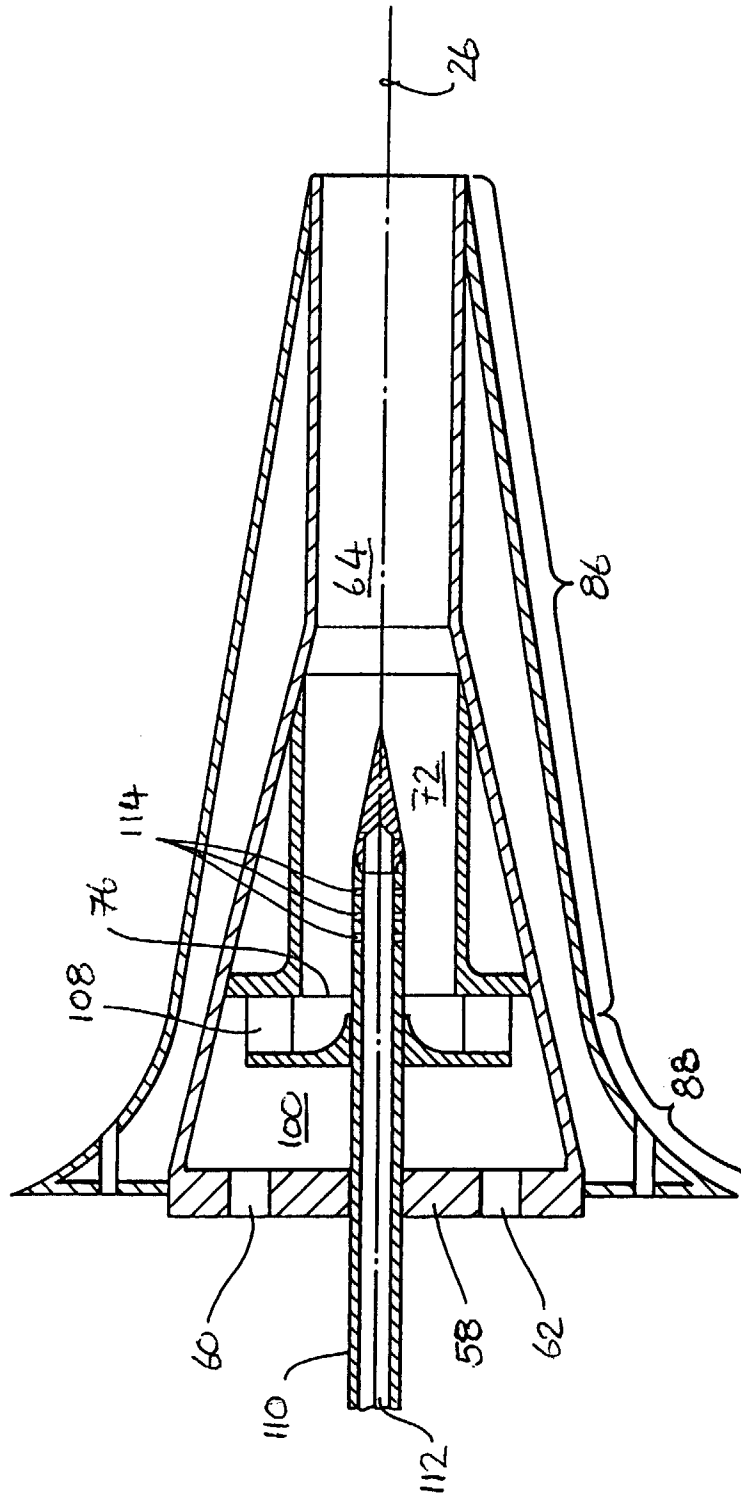

FIG. 6