

[54] ACTUATOR FOR AEROSOL CAN VALVE

[76] Inventor: Thomas J. Smrt, 31 W. 300 W. Bartlett Rd., Bartlett, Ill. 60103

[\*] Notice: The portion of the term of this patent subsequent to June 18, 1991 has been disclaimed.

[22] Filed: Aug. 29, 1973

[21] Appl. No.: 392,618

**Related U.S. Application Data**

[63] Continuation-in-part of Ser. No. 193,433, Oct. 28, 1971, Pat. No. 3,817,429, which is a continuation-in-part of Ser. No. 152,903, June 14, 1971, abandoned, which is a continuation-in-part of Ser. No. 118,351, Feb. 24, 1971, Pat. No. 3,700,144.

[52] U.S. Cl. .... 222/402.17; 239/394

[51] Int. Cl. .... B65d 83/14

[58] Field of Search.... 222/402.17, 402.21, 402.22, 222/402.23, 330, 331, 70, 504, 505; 239/394 X, 70, 274, 305, 597; 251/207, 208

[56] **References Cited**

**UNITED STATES PATENTS**

3,170,606	2/1965	Boyer.....	222/402.17 X
3,270,925	9/1966	Obst.....	222/402.21
3,700,144	10/1972	Smrt .....	222/176
3,704,831	12/1972	Clark .....	239/394
3,711,029	1/1973	Bartlett.....	239/394
3,817,429	6/1974	Smrt .....	222/402.22

Primary Examiner—Robert B. Reeves

[57] **ABSTRACT**

An actuator for an aerosol can valve which dispenses the contents of the can when the valve is moved laterally includes a base portion which is attached to the valve and an orifice portion which is provided with a plurality of different size spraying orifices. The base portion is provided with a bore which receives the valve stem of the can, and the orifice portion is rotatably mounted on the base to permit the spraying orifices to be selectively aligned with the bore of the base portion. Each spraying orifice is a rectangular slot having a long dimension which extends tangentially to the axis of rotation of the orifice portion. The actuator is intended for use with a spraying apparatus, and is provided with converging beveled surfaces at the lower end of the base portion and a flat surface on the upper portion of the base portion, to permit the long dimension of the rectangular slot which is aligned with the bore to be aligned in a desired direction with respect to the spraying apparatus. The bevel surfaces extend angularly with respect to the axis of the bore and parallel to the long dimension of the rectangular slot aligned with the bore, and the flat surface extends parallel to the axis of the bore and to the long dimension of the slot aligned with the bore.

**3 Claims, 8 Drawing Figures**

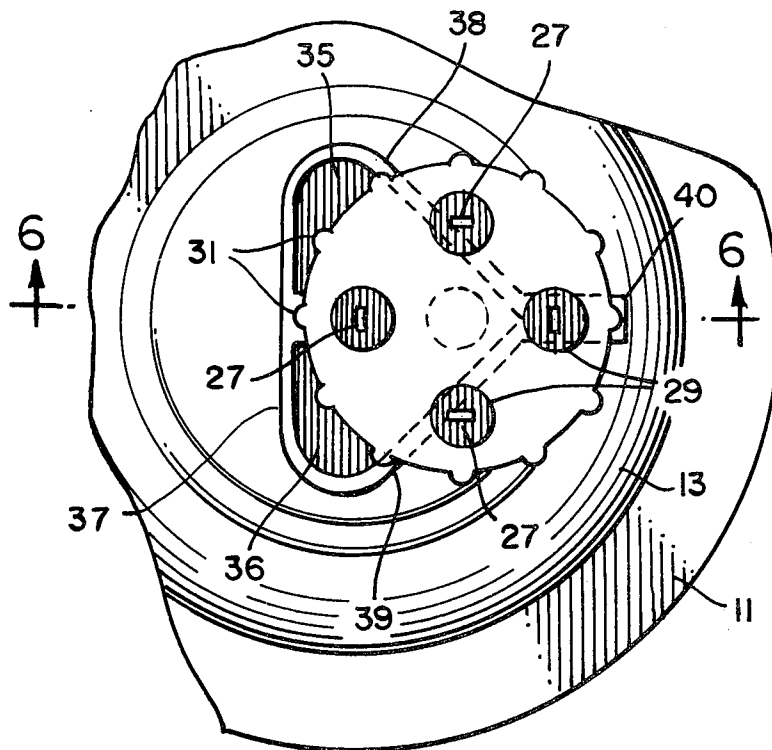

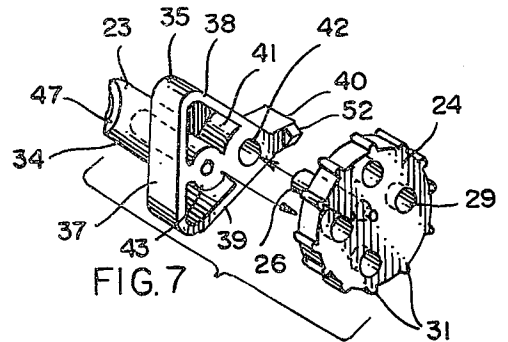
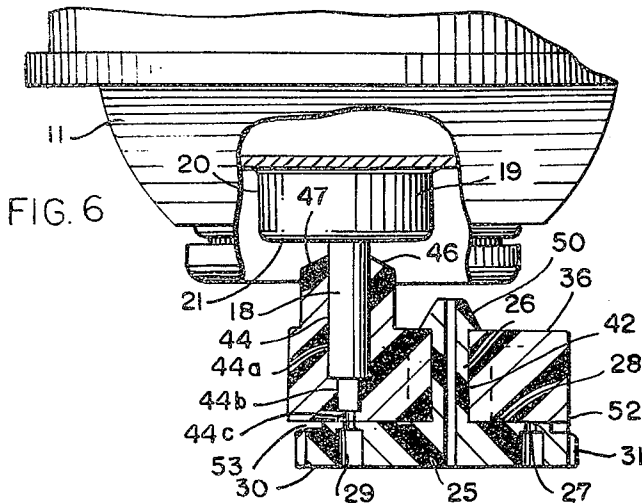
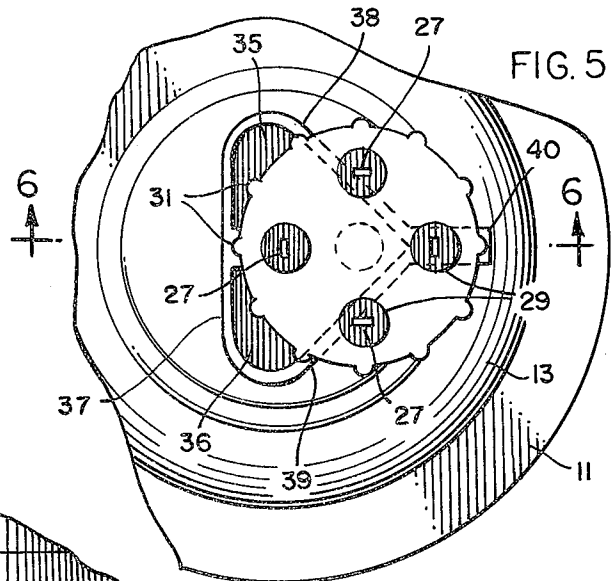
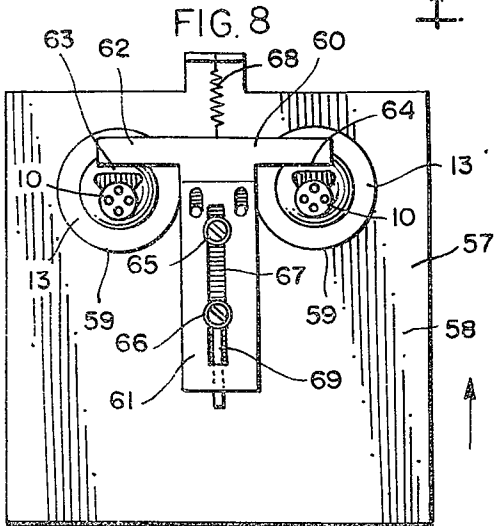
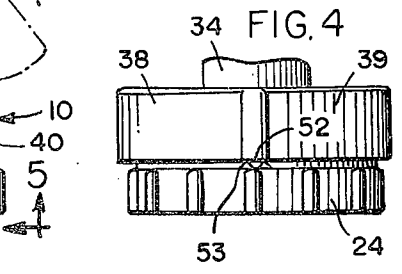
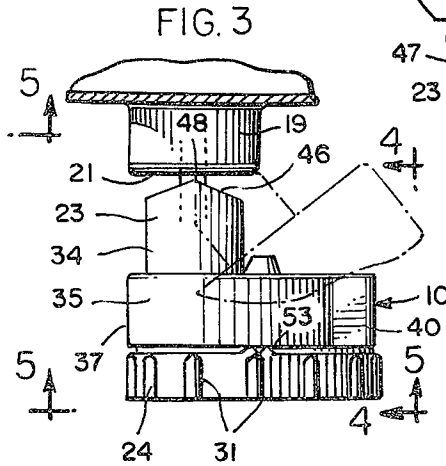
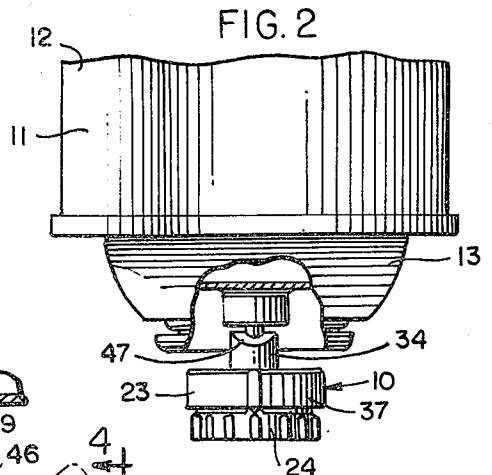
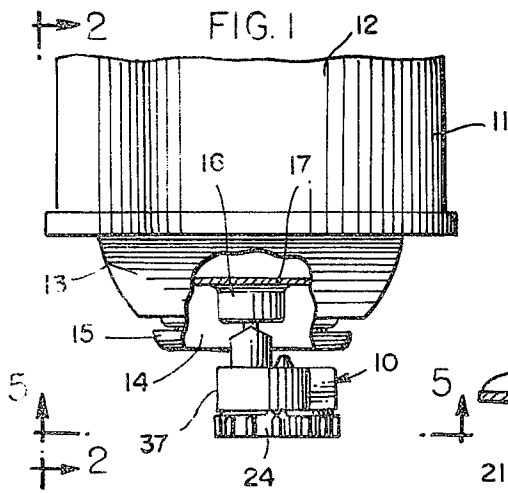

## ACTUATOR FOR AEROSOL CAN VALVE RELATED APPLICATION

This application is a continuation-in-part of my prior application entitled "Actuator For Aerosol Can Valve," Ser. No. 193,433, filed Oct. 28, 1971, now U.S. Pat. No. 3,817,429 which was a continuation-in-part of my application entitled "Actuator For Aerosol Can Valve," Ser. No. 152,903, filed June 14, 1971, now abandoned, which was a continuation-in-part of my prior application entitled "Spraying Apparatus," Ser. No. 118,351, filed Feb. 24, 1971 now U.S. Pat. No. 3,700,144.

### BACKGROUND AND SUMMARY

This invention relates to an actuator for the valve of an aerosol spray can, and, more particularly, to an actuator which includes a rotatable orifice portion provided with a plurality of different size spraying slots, the actuator being provided with aligning means for aligning the long dimension of the spraying slot which is being used in a desired direction.

Aerosol spray cans are commonly used for a variety of purposes such as painting, marking, and the like. When a spray can is to be used to mark a surface, such as marking a stripe on pavement, it is often desirable to use a spray nozzle having a slotted orifice which will provide a relatively wide spray. However, unless the slotted orifice is aligned transversely to the direction in which the can is being moved during the marking operation, the aerosol can will not be used with maximum effectiveness.

Aerosol cans are available with valves which include a stem extending axially from the can, and the valve may be opened by moving the stem laterally. However, the stem of this type of valve is frequently not accurately aligned with the axis of the can, and the stem will therefore direct the contents of the can at an angle relative to the can axis.

Since it might be desirable to spray a number of different stripes having varying widths, it is desirable that the actuator have the capability of spraying different size stripes without having to carry a plurality of actuators and physically changing the actuator for each stripe.

The invention provides an actuator for an aerosol can valve which has a base portion which is attached to the valve stem and an orifice portion which is rotatably mounted on the base portion and which is provided with a plurality of spraying slots. The spraying slots are of varying sizes, and the particular sized slot desired for a particular application is selected by rotating the orifice portion until that slot is aligned with the bore through the base portion. The base portion is provided with a flat side surface which extends parallel to the axis of the bore and to the long dimension of the spraying slot which is aligned with the bore, and the base portion terminates in a pair of flat beveled surfaces which extend angularly with respect to the bore and parallel to the long dimension of the slot aligned with the bore. The actuator is designed to be used with an actuating bar for opening the valve which moves generally transversely to the axis of the can, and as the bar engages the flat side surface of the portion, it provides a force which tends to rotate the actuator on the valve stem to align the long dimension of the selected spraying slot with the actuating bar. As the actuating bar continues

to move transversely with respect to the axis of the can, the actuator and the valve stem will be moved laterally relative to the axis of the can, and one of the beveled surfaces of the base portions will engage the flat base of the valve. As the actuator continues to be moved laterally, the engagement of the beveled surface will provide an additional force which tends to rotate the actuator on the valve stem to align the long dimension of the selected spraying slot with the actuating bar. The actuator will continue to rotate as it is moved laterally until the flat beveled surface comes into full engagement with the base of the valve. The engagement of the flat beveled surface with the base of the valve also serves to insure alignment of the valve stem and the bore of the actuator in a plane which extends through the axis of the can and perpendicularly to the slot.

### DESCRIPTION OF THE DRAWING

The invention will be explained in conjunction with an illustrative embodiment shown in the accompanying drawing, in which

FIG. 1 is a fragmentary side view of an inverted aerosol can, partially broken away, which is equipped with a valve actuator formed in accordance with the invention;

FIG. 2 is a front view of the aerosol can and actuator taken along the lines of 2—2 FIG. 1, the aerosol can being partially broken away;

FIG. 3 is an enlarged fragmentary view of a portion of FIG. 1 showing the movement of the actuator in dotted outline;

FIG. 4 is a fragmentary view taken along the line 4—4 of FIG. 3;

FIG. 5 is an enlarged fragmentary plan view taken along the line 5—5 of FIG. 3;

FIG. 6 is a fragmentary section view taken along the view line of 6—6 of FIG. 5;

FIG. 7 is a perspective exploded view of the actuator; and

FIG. 8 is a bottom view of a spraying apparatus holding a pair of actuator-equipped aerosol cans.

### DESCRIPTION OF SPECIFIC EMBODIMENT

Referring now to FIGS. 1—4, the numeral 10 designates generally an actuator or spray nozzle for an aerosol can 11. The aerosol can is conventional and includes a cylindrical body 12 and a generally dome-shaped top 13 which is provided with a central opening 14 closed by a cup-like cap 15. A valve 16 is mounted on the flat bottom 17 of the cap.

The can valve 16 is of the type which includes a tubular valve stem 18 (FIG. 6) which extends axially from a cup-shaped cylindrical valve base 19. The valve base includes a generally cylindrical side wall 20 and a flat top wall 21 which extends generally perpendicularly to the axis of the can and the valve stem. Since the valve is conventional and well known in the art, it need not be explained in detail.

The valve is opened by pivoting the valve stem laterally, i.e., away from the axis of the can, the stem being pivotable about a point within the valve base. When the valve is opened, the contents of the can are expelled through the central bore of the valve stem.

The aerosol can does not include a dip tube, and the can is therefore held in a generally inverted position as shown in FIG. 1 when the valve is opened.

The actuator 10 includes a base portion 23 and a generally wheel-shaped orifice portion 24 (FIG. 7) which is rotatably mounted on the base portion. The wheel-shaped orifice portion includes a generally cylindrical top portion 25 (FIG. 6) and a cylindrical attaching stem 26 which extends downwardly from the center of the cylindrical top portion. Four rectangular spraying slots 27 (FIG. 5) extend upwardly from the bottom surface 28 of the orifice portion, and each spraying slot communicates with an enlarged cylindrical counter-bore 29 which extends downwardly from the upper surface 30 of the spraying slot. Each of the rectangular slots has a long dimension which extends tangentially to an arc drawn with respect to the center of the cylindrical top of the orifice wheel, and the dimensions of each of the slots varies to provide different spraying characteristics. The outer cylindrical side wall of the orifice wheel is provided with radially outwardly extending knurls 31 to facilitate rotation of the orifice wheel with respect to the base portion.

The base portion 23 includes a generally cylindrical valve-attaching bottom portion 34 and a top portion 35 which is generally triangularly shaped in plan view (FIGS. 5 and 7). The triangularly shaped top portion 35 includes a bottom wall 36 (FIG. 5), a flat front side wall 37, a pair of rearwardly converging side walls 38 and 39, and a rearwardly extending tail portion 40. The top portion 35 is also provided with a generally cylindrical reinforcing portion 41 through which a bore 42 is provided, and a generally cylindrical portion 43 through which the spraying bore 44 (FIG. 6) of the base portion extends.

The cylindrical valve-attaching portion 34 extends downwardly from the top portion 35 axially with respect to the bore 44 and terminates in a valve-engaging end which is provided with a pair of flat beveled surfaces 46 and 47. The beveled surfaces converge along an edge 48 (FIG. 3) which extends parallel to the long dimension of the particular spraying slot 27 which is aligned with the bore 44 of the base portion and transversely to the axis of the valve stem 18. The planes of the beveled surfaces extend angularly with respect to the axis of the valve stem and generally parallel to the long dimension of the spraying slot which is aligned with the bore 44, i.e., the long dimension of the spraying slot would never intersect either plane no matter how far the long dimension was extended.

The plane of the flat front surface 37 of the top portion 35 also extends parallel to the long dimension of the spraying slot which is aligned with the bore 44 and parallel to the axis of the valve stem 18.

The bore 44 which extends through the valve-attaching portion and the top portion of the actuator base includes a major portion 44a having a diameter sized to receive the valve stem 18 of the can valve relatively snugly, a radially reduced portion 44b, and a still further reduced end portion 44c which provides an orifice or outlet opening in the top of the base portion which is aligned with one of the spraying orifices 27.

The base 42 through the top portion of the actuator base is sized to rotatably receive the attaching stem 26 of the orifice wheel, and the orifice wheel is secured to the base portion by inserting the stem 26 through the bore 42. Advantageously, the end of the stem 26 is provided with a frustoconical outer surface 50 (FIG. 6) which terminates in an angular shoulder extending radially outwardly from the remainder of the stem. The

shoulder provided by the frusto-conical end portion of the stem engages the bottom wall 36 of the top portion of the actuator base when the stem is inserted through the bore 42 and holds the bottom surface of the orifice wheel relatively snugly against the top of the base portion and prevents withdrawal of the orifice wheel from the base portion.

The center of the outlet 44c of the bore 44 through the actuator base is spaced from the axis of the bore 42 the same distance as the center of each of the spraying slots 27, and the orifice wheel can be rotated with respect to the base portion to align each of the spraying slots with the outlet 44c of the bore.

In order to insure that the desired spraying slot is precisely aligned with the outlet 44c, a V-shaped detent 52 (FIGS. 4 and 7) extends upwardly from the end of the tail portion of the actuator base. This detent is receivable by V-shaped grooves provided by pairs of saw-tooth shaped projections 53 located around the lower periphery of the orifice wheel. The particular orifice wheel illustrated is provided with four spraying slots, and four sets of detent-receiving saw tooth projections 53 are provided around the periphery of the orifice wheel. The spraying slots are spaced at 90° intervals around the center of the orifice wheel, and the saw tooth projections 53 are likewise spaced at 90° intervals around the center of the orifice wheel. The tail portion 40 of the actuator base is aligned with the centers of the bores 42 and 44 of the actuator base, and each of the detent-receiving grooves provided by the projections 53 is accordingly aligned with a radius extending from the center of the orifice wheel through the center of a spraying slot.

The particular sized spraying slot which is desired is aligned with the outlet 44c of the base 44 by rotating the wheel-shaped orifice portion. As each spraying slot approaches the outlet 44c, the detent 52 engages the inclined surface of one of the associated saw-tooth projections 53. As the orifice wheel is continued to be rotated, the saw-tooth projections are cammed away from the actuator base to permit the detent 52 to be received in the groove therebetween. Since the detent is located diametrically opposite to the spraying slot which is being brought into alignment with the outlet 44c, this camming action does not interfere with the engagement of the orifice wheel with the actuator base around the outlet 44c, and, indeed, facilitates this engagement.

The actuator is positioned on the valve by inserting the valve stem into the major portion 44a of the bore through the valve-attaching portion and pushing the actuator axially along the stem. The actuator is advantageously positioned on the stem so that the bottom of the valve-attaching portion is spaced slightly from the flat top of the valve base 21 — a spacing of the order of about one thirty-second to one sixteenth inch. This spacing insures that the valve will be opened fully as the actuator cap and stem are moved laterally with respect to the axis of the can. If desired, this spacing can be achieved relatively easily by providing the enlarged portion 44a of the bore with a length less than the length which the valve stem extends above the valve base by an amount corresponding to the desired spacing. The actuator can thus be pushed onto the valve stem until the valve stem engages the shoulder provided by the reduced bore portion 44b.

The actuator-equipped aerosol can is adapted for use in the spraying apparatus described in my prior patent entitled "Spraying Apparatus," U.S. Pat. No. 3,700,144, to which reference may be had for details. A portion of the apparatus 56 is shown in FIG. 8, the apparatus including a base plate 58 which is provided with a pair of openings 59 for receiving the domelike 13 of a pair of actuator-equipped aerosol cans. The openings 59 have a diameter slightly less than the maximum of the diameter of the dome portions so that these portions of the can can be held rather securely in the openings.

The valves are operated by a generally T-shaped bar 60 which is slidably attached to the lower surface of the base plate 58. The actuating bar includes an elongated sliding or attaching portion 61 and a transversely extending valve-actuating portion 62 having a pair of generally flat actuating edges 63 and 64. The slide portion 61 is slidably secured to the base plate between the openings 59 therethrough by bolts 55 and 56 which extend through a longitudinal extending slot 67 in the slide portion. The enlarged head portions of the bolts hold the slide portion adjacent the base plate, and the shank portions of the bolts cooperate with the slot 67 to guide the sliding movement of the slide plate along a line equidistant from the centers of the opening 59.

The valve-actuating portion 62 of the actuating bar is positioned relative to the actuators to engage the flat front sides 37 of the actuator bases, and the actuating bar is biased to a non-actuating position shown in FIG. 8 in which the actuating bar does not engage the actuators by a spring 68 which is secured to the frame of the spraying apparatus. Sliding movement is imparted to the actuating bar by a bell crank 69 which extends downwardly through a slot in the base plate and through the rearward portion of the slot 67 in the actuating bar.

Although the actuators 10 are frictionally engaged with the valve stem 18, the actuators can be rotated about the stem without difficulty. When the aerosol cans are inserted into the spraying apparatus, it is usually difficult to align the long dimension of the spraying slot which is to be used in a direction transverse to the direction in which the spraying apparatus is to be advanced, indicated by the arrow A in FIG. 8, particularly since the cans are inverted and are enclosed within the casing of the spraying apparatus. However, when the valves of the cans are to be opened by sliding the actuator bar rearwardly and downwardly as viewed in FIG. 8, the flat leading edges 63 and 64 of the actuating bar will engage the flat aligning front side surfaces 37 of the actuators. The front side surface 37 of each of the actuators extends parallel to the long dimension of the spraying slot which is aligned with the outlet 44c, and if the long dimension of this spraying slot does not extend perpendicular to the direction of which the apparatus is being advanced, the actuating bar will exert a force on the actuator which will tend to rotate the actuator about the valve stem 18 until the leading edge of the actuator bar becomes flush with the flat front side surface 37 of the actuator.

Engagement of the actuating bar with the actuator will also exert a force which will tend to pivot the actuator and the valve stem laterally relative to the axis of the can. This will bring the rear beveled surface 46 of the actuator into engagement with the flat valve base 21 as illustrated in phantom in FIG. 3. If the frictional

engagement of the actuator with the valve stem is such that engagement of the actuating bar with the actuator is insufficient to rotate the actuator to bring the flat front surfaces 37 into alignment with the leading edge of the actuator bar, engagement of the beveled surface 46 with the valve base 21 will provide an additional force tending to rotate the actuator until the long dimension of the spraying slot that is being used and the front surface 37 become aligned with the actuating bar. This is due to the fact that as the beveled surface is forced against the flat base surface 21, the beveled surface will tend to align itself in a parallel relationship with the flat base 21 so that the beveled surface can become fully engaged with the surface 21. When this occurs, the long dimension of the spraying slot will be aligned parallel to the leading edge of the actuator bar, i.e., transverse to the direction in which the beveled surface extends parallel to the long dimension of the spraying slot.

The beveled surface 46 also serves to bring the valve stem into alignment with a plane which extends through the axis of the can and transversely to the flat front surface 37, i.e., a plane which extends in the direction in which the spraying apparatus is advanced. This is advantageous since at times the valve stem extends slightly askew from the axis of the can in a direction to the right or left of the direction in which the spraying apparatus is advanced. For example, as seen in FIG. 8, the stems of some cans may extend angularly to the right or left of the position illustrated. As cans are emptied and placed with new cans such misalignment can cause the spray pattern laid down by the new cans to be an inch or more to the right or left of the previous patterns.

Since the beveled surface 46 can come into full engagement with the flat base 21 only when the valve stem is aligned with a plane extending through the axis of the can, the beveled surface will correctly align the valve stem as the beveled surface is forced into full engagement with the valve base 21 by the actuating bar.

If the actuator is to be used with a spraying apparatus such as illustrated in FIG. 8, in which an actuating bar engages the front surface 37 of the actuator, only the rear beveled surface 46 need be provided since the actuator and the stem will always be moved to the right as viewed in FIG. 3. The front beveled surface 47 is advantageous if the can is to be used with a spraying apparatus in which the valve is opened by moving the actuator to the left as viewed in FIG. 3.

In one specific embodiment of the invention, the beveled surfaces 46 and 47 formed an included angle of about 140° so that each surface extended at an angle of about 20° relative to the flat surface 21 of the valve based and an angle of about 70° relative to the axis of the bore 44.

When it is desired to spray a stripe having a different width, another spraying slot can be rotated into alignment with the orifice 44c. The orifice wheel can be rotated to position the desired spraying slot without removing the actuator from the valve stem, and the detent means will insure proper alignment of the spraying slot with the orifice 44c. The spraying slot is held snugly against the top of the base portion around the outlet 44c, by the frusto-conical end portion of the attaching stem 26 so that the contents of the can are expelled through the spraying without leaking.

While in the foregoing specification, a detailed description of a specific embodiment of the invention was set forth for the purpose of illustration, it is to be understood that many of the details herein given may be varied considerably by those skilled in the art without departing from the spirit and scope of the invention.

I claim:

1. An actuator for an aerosol can valve comprising a base portion and an orifice portion, the base portion having a pair of ends and a bore extending there-  
through from one end to the other, the orifice portion having a plurality of rectangular spraying orifices of various sizes and being rotatably mounted on one end of the base portion for rotation about an axis extending parallel to the bore at said one end, the spacing between the spraying orifices and the axis of rotation being substantially the same as the spacing between the bore at said one end and the axis of rotation whereby the spraying orifices can be selectively aligned with the bore at said one end, the base portion having a flat aligning side surface adapted to be engaged with aligning means of a spray apparatus for rotating the actuator on the aerosol can valve when the flat aligning side surface of the base portion is engaged with the aligning means of the spray apparatus, each of the rectangular spraying orifices having a long dimension extending tangentially to an arc drawn with respect to the axis of rotation of the orifice portion, the flat side surface of the base portion extending parallel to the long dimension of the spraying slot which is aligned with the bore and parallel to the axis of the bore at said one end whereby the long dimension of the spraying orifice

5  
10  
15  
20  
25  
30  
35  
40  
45  
50  
55  
60  
65

which is aligned with the bore may be aligned with respect to the spraying apparatus by engaging the aligning means of the spraying apparatus with the flat side surface of the base portion.

2. An actuator for an aerosol can valve comprising a base portion and an orifice portion, the base portion having a pair of ends and a bore extending there-  
through from one end to the other, the orifice portion including a substantially cylindrical body having generally flat upper and lower surfaces provided with a plurality of spraying orifices and a cylindrical shaft extending from the center of the cylindrical body perpendicular to the upper and lower surfaces, the base portion being provided with a second bore which rotatably receives the shaft, the base portion having a flat aligning side surface positioned radially outwardly of the cylindrical body of the orifice portion and adapted to be engaged with aligning means of a spray apparatus for rotating the actuator on the aerosol can valve when the flat aligning side surface of the base portion is engaged with the aligning means of the spray apparatus, portions of the cylindrical body of the orifice portion extending radially outwardly beyond the base portion whereby the orifice portion can be grasped and rotated with respect to the base portion to selectively align the spraying orifices with the bore.

3. The actuator of claim 2 in which the lower end of the shaft extends through the base portion and includes locking means for holding the lower surface of the cylindrical body of the orifice portion against the base portion.

\* \* \* \* \*