



US00D887591S

(12) **United States Design Patent**
Mack et al.

(10) **Patent No.:** **US D887,591 S**

(45) **Date of Patent:** **** Jun. 16, 2020**

(54) **DAYTIME RUNNING LIGHT**
(71) Applicant: **GM GLOBAL TECHNOLOGY OPERATIONS LLC**, Detroit, MI (US)
(72) Inventors: **John P. Mack**, Rochester Hills, MI (US); **Casey Swanseger**, Lake Orion, MI (US)
(73) Assignee: **GM GLOBAL TECHNOLOGY OPERATIONS LLC**, Detroit, MI (US)
(**) Term: **15 Years**
(21) Appl. No.: **29/611,448**

D605,977 S 12/2009 Zipfel et al.
D605,978 S 12/2009 Wolff et al.
D608,249 S 1/2010 Peters
D608,690 S 1/2010 Folden et al.
D608,691 S 1/2010 Zak, Jr. et al.
D609,608 S 2/2010 Boniface et al.
D611,387 S 3/2010 Thompson et al.
D611,879 S 3/2010 Kim et al.
D612,297 S 3/2010 Peters et al.
D613,645 S 4/2010 Song et al.
D615,458 S 5/2010 Thompson et al.
D618,595 S 6/2010 Ware et al.
D623,090 S 9/2010 Cox et al.
D627,262 S 11/2010 Ikeda et al.
D635,488 S 4/2011 Phipps
D644,147 S 8/2011 Suh et al.

(Continued)

(22) Filed: **Jul. 21, 2017**
(51) **LOC (12) Cl.** **26-06**
(52) **U.S. Cl.**
USPC **D26/28**
(58) **Field of Classification Search**
USPC D12/86, 90-92, 114, 163, 169, 171-173, D12/181, 190, 196, 197, 199, 400; D26/28-36, 139
CPC ... B62J 6/02; B62J 6/00; B60Q 3/0279; F21S 48/00; F21S 48/10; F21S 48/115; F21S 48/225; F21S 48/1233; F21S 48/1266; F21S 48/1388; F21S 48/2268; F21V 21/04
See application file for complete search history.

OTHER PUBLICATIONS

Amazon | Headlights Depot Replacement for Chevy Silverado 1500 2500 3500 . . . , first available on Jun. 29, 2010, © 1996-2018, Amazon.com, Inc. [online], [site visited Oct. 1, 2018]. Available from Internet, <URL: <https://www.amazon.com/Headlights-Depot-Replacement-Chevrolet-Silverado/dp/B003U82ZVG/>> .*

Primary Examiner — Philip S Hyder
Assistant Examiner — Cary M Robinson

(57) **CLAIM**

The ornamental designs for a daytime running light, as shown and described.

(56) **References Cited**

U.S. PATENT DOCUMENTS

D570,742 S 6/2008 Takagi et al.
D592,105 S 5/2009 Dean et al.
D597,447 S 8/2009 Folden
D600,595 S 9/2009 Nakamura et al.
D601,925 S 10/2009 O'Donnell
D603,755 S 11/2009 Peters
D604,203 S 11/2009 O'Donnell
D605,082 S 12/2009 Munson
D605,083 S 12/2009 Manoogian, II et al.

DESCRIPTION

FIG. 1 is a perspective view of the daytime running light; FIG. 2 is a front view of the embodiment of FIG. 1; FIG. 3 is a side view of the embodiment of FIG. 1; and, FIG. 4 is a top view of the embodiment of FIG. 1. The broken lines in the drawings illustrate portions of the daytime running light that form no part of the claimed design.

1 Claim, 4 Drawing Sheets

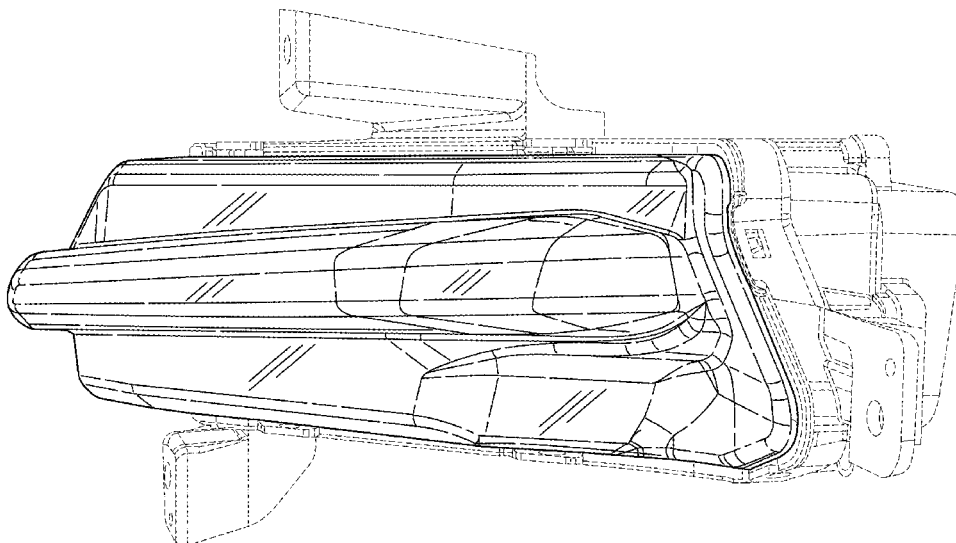

(56)

References Cited

U.S. PATENT DOCUMENTS

D644,567 S	9/2011	Kozub	D749,250 S	2/2016	Thole et al.
D657,718 S	4/2012	Zipfel et al.	D749,985 S	2/2016	Kozub et al.
D659,052 S	5/2012	Ware et al.	D749,997 S	2/2016	McMahan et al.
D659,053 S	5/2012	Ware et al.	D750,001 S	2/2016	Thole et al.
D668,182 S	10/2012	Franco et al.	D753,032 S	4/2016	Smith et al.
D668,183 S	10/2012	Smart	D753,033 S	4/2016	Thole et al.
D678,820 S	3/2013	Son et al.	D753,034 S	4/2016	Thole et al.
D678,821 S	3/2013	Ikeda et al.	D753,035 S	4/2016	Boniface et al.
D680,909 S	4/2013	Munson et al.	D753,559 S	4/2016	McMahan et al.
D680,910 S	4/2013	David	D753,560 S	4/2016	McMahan et al.
D684,899 S	6/2013	Baker	D753,567 S	4/2016	Boniface et al.
D686,536 S	7/2013	McCabe et al.	D754,571 S	4/2016	Boniface et al.
D692,798 S	11/2013	Thurber	D754,572 S	4/2016	McMahan et al.
D692,799 S	11/2013	Smith et al.	D755,088 S	5/2016	McMahan et al.
D696,157 S	12/2013	Loeb	D756,869 S	5/2016	McMahan et al.
D697,258 S	* 1/2014	Conway D26/139	D758,271 S	6/2016	McMahan et al.
D699,629 S	2/2014	Ikeda et al.	D764,975 S	8/2016	Aengenheyster
D700,871 S	3/2014	O'Donnell et al.	D764,976 S	8/2016	Aengenheyster
D703,103 S	4/2014	Lee	D767,449 S	9/2016	Pevovar et al.
D704,103 S	5/2014	Mack et al.	D767,450 S	9/2016	Lee et al.
D705,132 S	5/2014	Ware et al.	D767,451 S	9/2016	Kozub et al.
D705,699 S	5/2014	Ware et al.	D767,454 S	9/2016	McMahan et al.
D713,298 S	9/2014	Dyson	D767,458 S	9/2016	Kim
D713,764 S	9/2014	Ferlazzo et al.	D767,459 S	9/2016	Kim
D716,696 S	11/2014	Thole et al.	D767,460 S	9/2016	Kozub et al.
D716,706 S	11/2014	Thole et al.	D767,461 S	9/2016	Kozub et al.
D716,709 S	11/2014	Thole et al.	D769,477 S	* 10/2016	Gunnarson D26/28
D717,696 S	11/2014	Thole et al.	D771,528 S	11/2016	Smith et al.
D718,189 S	11/2014	Krieg et al.	D771,529 S	11/2016	Thole et al.
D718,683 S	12/2014	Thole et al.	D771,532 S	11/2016	Kapitonov
D722,282 S	2/2015	Loeb	D771,533 S	11/2016	Kapitonov
D722,533 S	2/2015	Thole et al.	D772,766 S	11/2016	Kozub et al.
D722,534 S	2/2015	Munson et al.	D772,767 S	11/2016	Kim
D724,510 S	3/2015	McMahan et al.	D773,084 S	11/2016	Kapitonov
D725,001 S	3/2015	McMahan et al.	D773,086 S	11/2016	McCabe et al.
D726,591 S	4/2015	Jacob	D774,226 S	12/2016	McCabe et al.
D730,776 S	6/2015	Smart	D775,003 S	12/2016	Pevovar et al.
D730,783 S	6/2015	Henriques et al.	D775,007 S	12/2016	Thole et al.
D732,427 S	6/2015	Loeb	D775,010 S	12/2016	Kim et al.
D732,429 S	6/2015	Loeb	D775,049 S	12/2016	Scheer et al.
D732,430 S	6/2015	Loeb	D775,549 S	1/2017	Karras
D732,431 S	6/2015	Loeb	D775,554 S	1/2017	Kapitonov
D732,432 S	6/2015	Aengenheyster	D776,020 S	1/2017	Kapitonov
D732,433 S	6/2015	Aengenheyster	D776,581 S	1/2017	Pevovar et al.
D732,435 S	6/2015	Mackay	D776,583 S	1/2017	Scheer et al.
D733,002 S	6/2015	Loeb	D776,841 S	1/2017	Kozub et al.
D735,611 S	8/2015	Aengenheyster	D776,843 S	1/2017	McCabe et al.
D735,627 S	8/2015	Smith	D776,846 S	1/2017	Willett et al.
D736,451 S	8/2015	Smith	D777,359 S	1/2017	Kozub et al.
D739,306 S	9/2015	McMahan	D777,360 S	1/2017	Kozub et al.
D739,317 S	9/2015	McMahan et al.	D777,361 S	1/2017	Kozub et al.
D741,223 S	10/2015	Kim et al.	D777,604 S	1/2017	McNerney
D743,309 S	11/2015	Thole et al.	D777,605 S	1/2017	Ferlazzo et al.
D743,313 S	11/2015	Smith et al.	D777,620 S	1/2017	Pevovar et al.
D743,314 S	11/2015	Thole et al.	D777,621 S	1/2017	Kim
D743,857 S	11/2015	McMahan et al.	D777,622 S	1/2017	Kozub et al.
D744,158 S	11/2015	Willett et al.	D777,628 S	1/2017	Kozub et al.
D745,086 S	12/2015	Finos et al.	D777,955 S	1/2017	Willett et al.
D745,719 S	12/2015	Boniface et al.	D778,212 S	2/2017	Kozub et al.
D745,725 S	12/2015	McMahan et al.	D778,215 S	2/2017	Kozub et al.
D745,726 S	12/2015	McMahan et al.	D780,064 S	2/2017	Smith et al.
D745,837 S	12/2015	Smith et al.	D780,067 S	2/2017	Zipfel et al.
D746,726 S	1/2016	Smith et al.	D780,068 S	2/2017	Whitla et al.
D746,727 S	1/2016	Smith et al.	D780,077 S	2/2017	Kim et al.
D746,728 S	1/2016	Smith et al.	D780,081 S	2/2017	Lee
D746,729 S	1/2016	Boniface et al.	D780,084 S	2/2017	Scheer et al.
D746,730 S	1/2016	Kim et al.	D780,631 S	3/2017	Kozub et al.
D747,514 S	1/2016	McMahan et al.	D780,644 S	3/2017	Kim et al.
D747,515 S	1/2016	McMahan et al.	D781,184 S	3/2017	Thole et al.
D747,819 S	1/2016	Thole et al.	D781,192 S	3/2017	Kozub et al.
D749,021 S	2/2016	Boniface et al.	D782,379 S	3/2017	Wassell
D749,026 S	2/2016	Smith et al.	D783,482 S	4/2017	Smith et al.
D749,027 S	2/2016	McMahan et al.	D784,213 S	4/2017	Karras
D749,246 S	2/2016	Thole et al.	D784,223 S	4/2017	Lee
D749,249 S	2/2016	Thole et al.	D784,226 S	4/2017	Cheng
			D784,579 S	4/2017	Cheng et al.
			D784,877 S	4/2017	Lee
			D784,886 S	4/2017	Smith et al.
			D785,521 S	5/2017	Smith et al.

(56)

References Cited

U.S. PATENT DOCUMENTS

D786,149	S	5/2017	Pevovar et al.	
D786,743	S	5/2017	Smith et al.	
D786,750	S	5/2017	Lee	
D787,446	S	5/2017	Cockerill	
D787,984	S	5/2017	Fang	
D787,988	S	5/2017	Lee	
D787,989	S	5/2017	Kozub et al.	
D787,990	S	5/2017	Kozub et al.	
D787,992	S	5/2017	Lee	
D787,993	S	5/2017	McCabe et al.	
D788,001	S	5/2017	Lee	
D788,641	S	6/2017	Arnold	
D788,644	S	6/2017	Mueller	
D788,645	S	6/2017	Mueller	
D789,250	S	6/2017	Arnold	
D789,260	S	6/2017	Smith	
D789,575	S	6/2017	Willett	
D789,841	S	6/2017	Malczewski	
D789,849	S	6/2017	Lee	
D791,018	S	7/2017	Mylenek	
D791,644	S	7/2017	Fang	
D792,622	S *	7/2017	Briscoe	D26/28
D796,088	S *	8/2017	McCabe	D26/28
9,766,393	B2 *	9/2017	Cabanne	G02B 6/0055
D809,683	S *	2/2018	Yates	D26/28
D832,473	S *	10/2018	Handt	D26/28
D842,508	S *	3/2019	Kim	D26/28
D843,025	S *	3/2019	Smith	D26/28

* cited by examiner

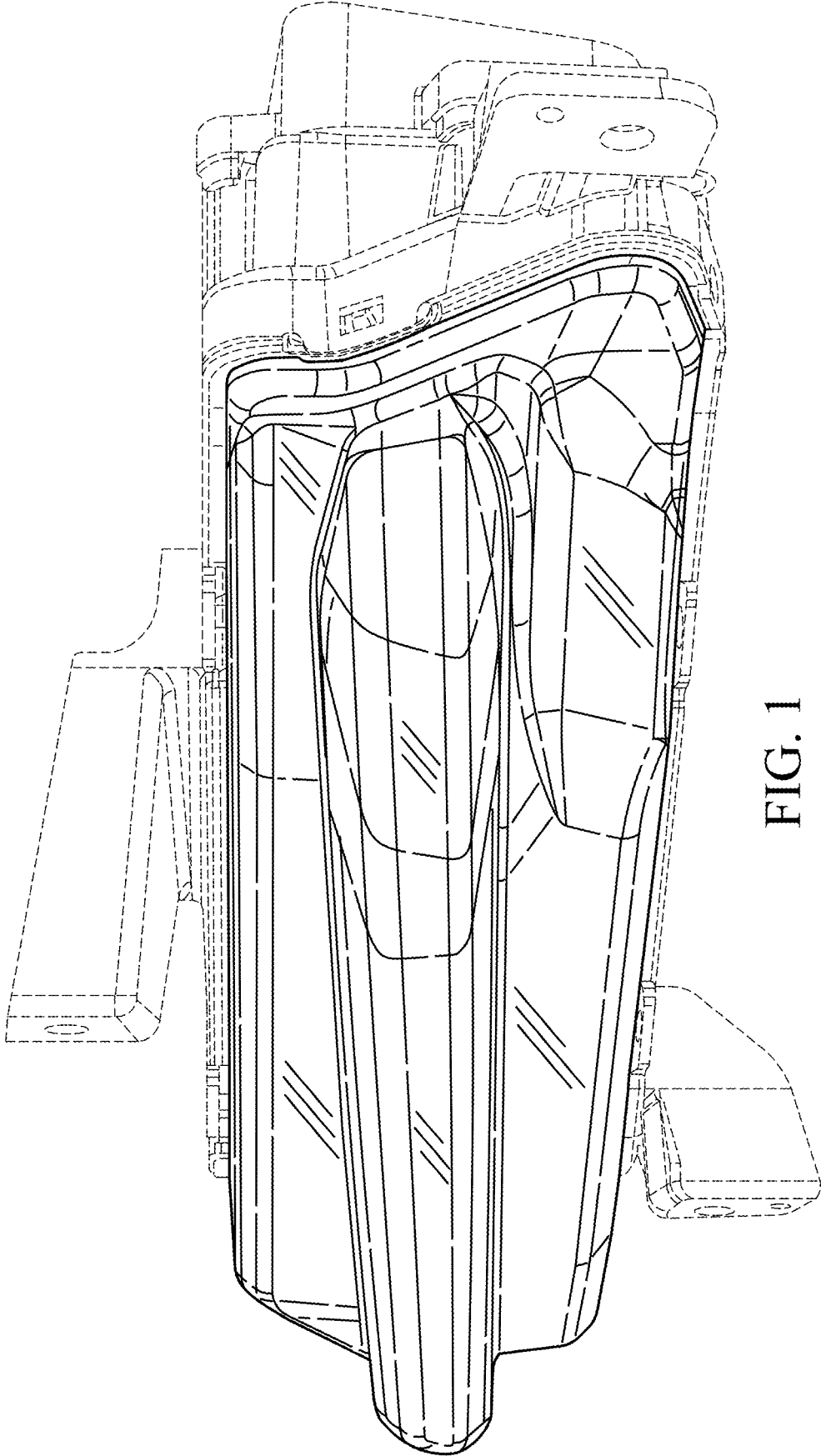

FIG. 1

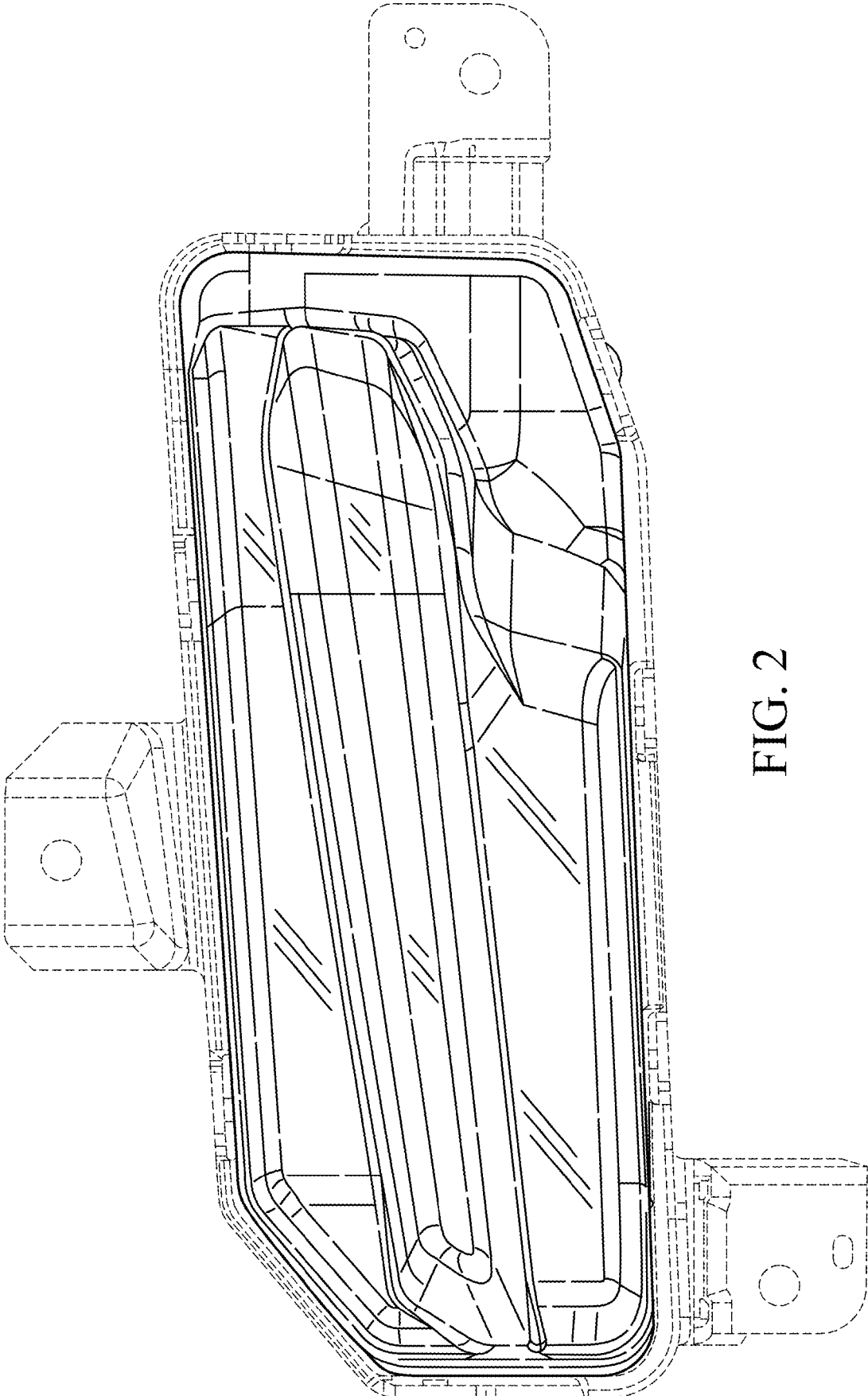
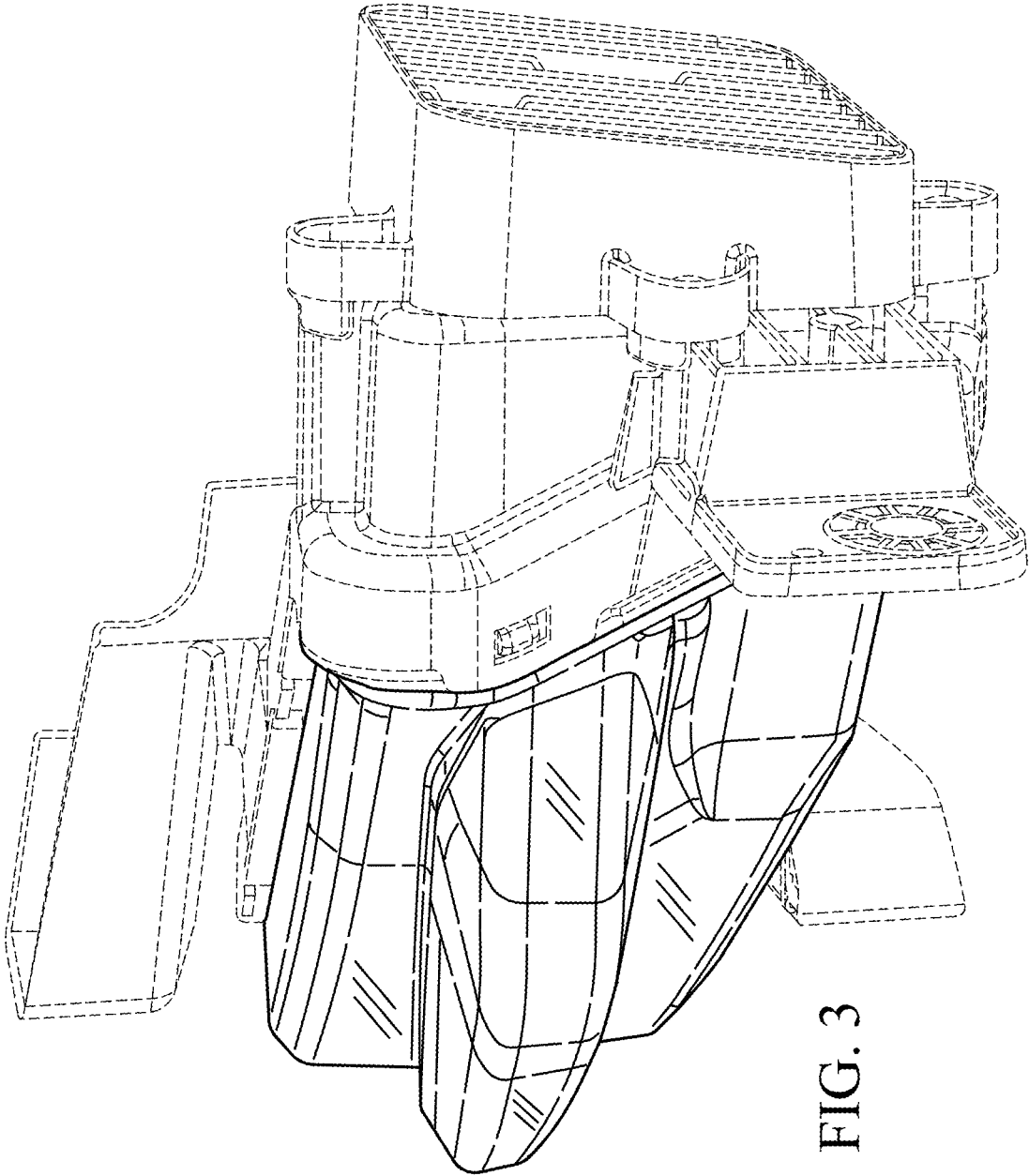

FIG. 2



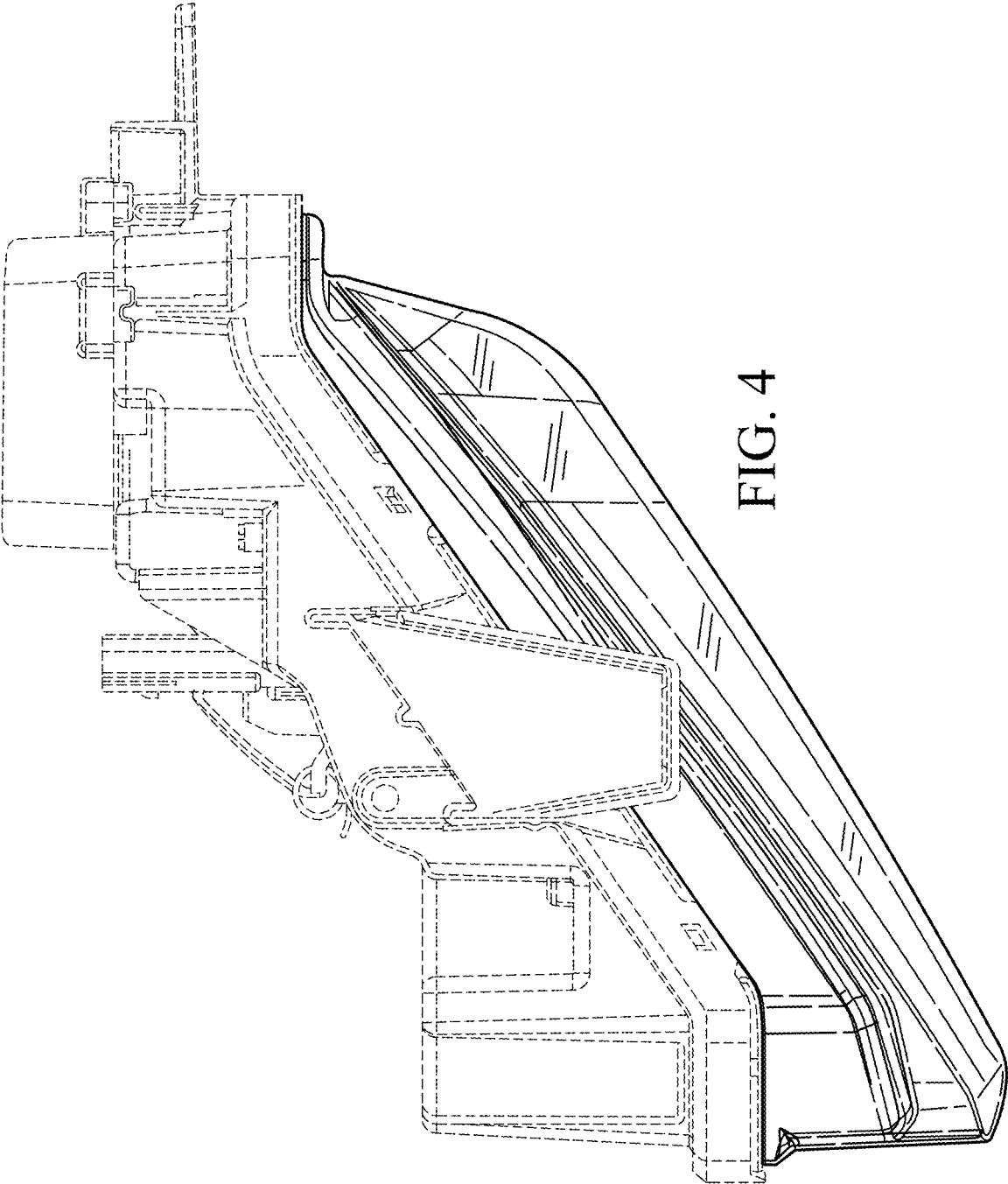

FIG. 4