



(22) Date de dépôt/Filing Date: 2019/01/08

(41) Mise à la disp. pub./Open to Public Insp.: 2019/03/13

(45) Date de délivrance/Issue Date: 2020/01/28

(51) Cl.Int./Int.Cl. *E02D 31/08* (2006.01),
E02D 27/01 (2006.01), *E02D 27/32* (2006.01),
E02D 27/34 (2006.01), *E04F 15/18* (2006.01)

(72) Inventeur/Inventor:
KOWALCHUK, JONATHAN, CA

(73) Propriétaire/Owner:
KOWALCHUK, JONATHAN, CA

(74) Agent: ADE & COMPANY INC.

(54) Titre : VADIR BARRIER : UNE SOUS-COUCHE DE DALLE DE BETON DOTE E D'UNE FORME DE VIDE TOUT-EN-UN, UNE BARRIERE D'AIR, UN PLAN DE DRAINAGE, UNE ISOLATION ET UNE PROTECTION CONTRE LE RADON

(54) Title: VADIR BARRIER: A CONCRETE SLAB UNDERLAYMENT WITH ALL-IN-ONE VOID FORM, AIR BARRIER, DRAINAGE PLANE, INSULATION AND RADON PROTECTION

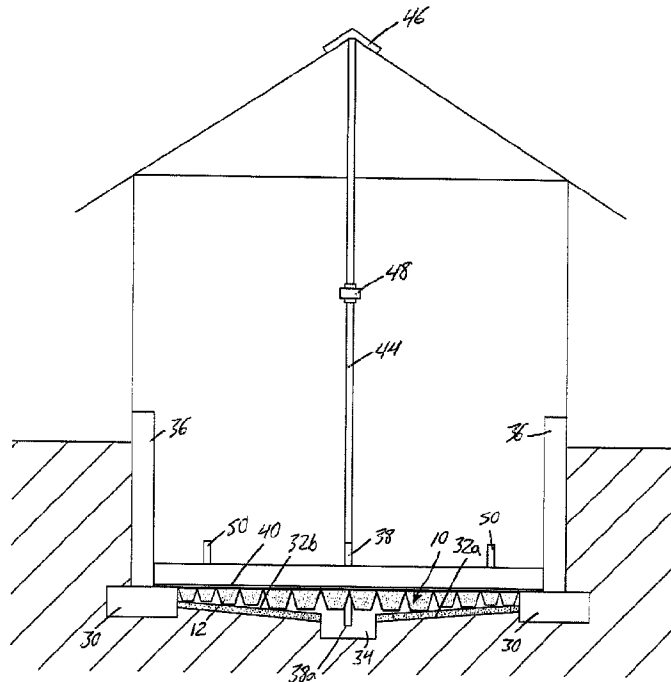

(57) Abrégé/Abstract:

A concrete slab underlayment product is used at an excavation area at which a concrete foundation slab is to be poured. The underlayment combines a vapour barrier layer with a set of foam insulation bodies. The vapour barrier layer spans fully over the

(57) **Abrégé(suite)/Abstract(continued):**

entire set of foam insulation bodies, which are spaced apart from one another at least at lower ends thereof opposite the vapour barrier layer. This leaves drainage/air spaces open between the foam insulation bodies when laid in an installed position atop the floor of an excavated area. In use under a concrete slab, the vapour barrier layer forms a gas and moisture barrier, and the foam insulation bodies and the drainage/air spaces therebetween form a combination of void spaces, drainage channels and insulation blocks between the concrete slab and the floor of the excavation area.

ABSTRACT

A concrete slab underlayment product is used at an excavation area at which a concrete foundation slab is to be poured. The underlayment combines a vapour barrier layer with a set of foam insulation bodies. The vapour barrier layer spans fully over the entire set of foam insulation bodies, which are spaced apart from one another at least at lower ends thereof opposite the vapour barrier layer. This leaves drainage/air spaces open between the foam insulation bodies when laid in an installed position atop the floor of an excavated area. In use under a concrete slab, the vapour barrier layer forms a gas and moisture barrier, and the foam insulation bodies and the drainage/air spaces therebetween form a combination of void spaces, drainage channels and insulation blocks between the concrete slab and the floor of the excavation area.

VADIR Barrier: a concrete slab underlayment with all-in-one void form, air barrier, drainage plane, insulation and radon protection

FIELD OF THE INVENTION

The present invention relates generally to building foundation construction techniques, and more specifically to products and techniques used in preparation of excavated areas in which concrete foundation slabs are to be poured in-situ.

BACKGROUND

In construction of concrete foundations, void forms are employed for the purpose of creating voids in the underside of a concrete slab to accommodate swelling of expansive soil therebeneath, which otherwise can cause shifting and cracking of the slab. Existing void form products are typically block or box-shaped units formed of cardboard, or a solid foam material such as expanded polystyrene. Such void form units are individually laid out over the floor of the excavated area in an appropriate pattern or array, followed by an overlay of hardboard placed atop the void form units, and a final layer of vapour barrier sheeting placed atop the hardboard. The concrete slab is then poured atop the vapour barrier sheeting. A shortcoming of cardboard void forms is the potential for premature degradation or collapse thereof if exposed to rainwater or other excessive moisture before the concrete is poured. Shortcomings of foam void forms include typically greater cost, environmental impact, and their lightweight nature making them susceptible to potential disruption in windy environments.

Regardless of the particular material composition of the void forms and the associated drawbacks thereof, the preparation of the area before pouring the concrete is an inefficient multi-step process involving the placement of individual void

forms in a first layer, followed by separate placement of subsequent hardboard and vapour barrier layers.

Accordingly, there remains room for improvements and alternatives concerning preparatory techniques for in-situ pouring of concrete slab foundations.

5 SUMMARY OF THE INVENTION

According to one aspect of the invention, there is provided a concrete slab underlayment for use at an area at which an in-situ concrete slab is to be poured, said underlayment comprising:

an upper vapour barrier layer comprising at least one material that is
10 substantially impermeable to gas and vapour; and

a set of insulation bodies that are materially distinct from the at least one material of the upper vapour barrier layer, and are secured to said upper vapour barrier layer in underlying relation thereto at a central non-margin area thereof;

wherein said upper vapour barrier layer spans fully over all of said
15 insulation bodies, said insulation bodies are spaced apart from one another at least at lower ends thereof opposite the upper vapour barrier layer to leave drainage/air spaces open between the lower ends of said insulation bodies when laid in an installed position atop a floor surface of said area; and

wherein said at least one material of the upper vapour barrier layer
20 comprises flexible sheeting, at least at outer margins of said upper vapour barrier layer that reside along respective perimeter edges of the vapour barrier layer outside the central non-margin area occupied by the insulation bodies;

whereby in use in said installed position under a concrete slab poured
over said underlayment, the vapour barrier layer forms a gas and moisture barrier
25 beneath said concrete slab, and the insulation bodies and the drainage/air spaces

therebetween form a combination of void spaces, drainage channels and insulation blocks between said floor surface and said concrete slab.

Preferably said insulation bodies comprise recycled foam.

According to another aspect of the invention, there is provided a method
5 of preparing an area for an in-situ concrete slab, said method comprising:

(a) atop a floor surface of said area, laying down a plurality underlayments
of the forgoing type; and

(b) sealing together the vapour barrier layers of said plurality of
underlayments at the outer margins thereof to create a gapless span of said vapour
10 barrier layers across said floor surface.

BRIEF DESCRIPTION OF THE DRAWINGS

Preferred embodiments of the invention will now be described in
conjunction with the accompanying drawings in which:

Figure 1 is an overhead plan view of a concrete slab underlayment
15 according to one embodiment the present invention.

Figure 2 is a partially exploded side elevational view of the underlayment
of Figure 1.

Figure 3 is an assembled side elevational view of the underlayment of
Figure 2.

20 Figure 4 is an assembled side elevational view illustrating a variant of the
cross-sectional shape of the underlayment of Figure 3.

Figure 5 is an assembled side elevational view illustrating another variant
of the cross-sectional shape of the underlayment of Figure 3.

25 Figure 6 is an end elevational view of the underlayment of any one of
Figures 3 through 5.

Figure 7 is a schematic cross-sectional view of a house featuring a concrete foundation produced in accordance with the present invention using underlayments of varying thickness.

Figure 7A is a schematic cross-sectional view similar to Figure 7, but with underlayments of uniform thickness.

Figure 8 is an overhead plan view illustrating overlapped placement of two underlayments of Figure 1 relative to a sump pit during installation of said underlayments to enable water drainage to said sump pit after pouring of a concrete slab atop said underlayments.

Figure 9 is an end elevational view illustrating use of overhanging margins of the underlayments of Figure 8 to seal the two underlayments together during installation prior to pouring of said concrete slab.

Figure 10 is a bottom plan view of a second embodiment of the concrete slab underlayment.

Figure 11 is a side elevational view of the underlayment of figure 10.

Figure 12 is a side elevational view of two underlayments of the type shown in Figures 10 and 11 stacked together in inverted and intermeshing fashion for space efficient transport and storage before installation.

DETAILED DESCRIPTION

Figure 1 shows an overhead plan view of a concrete slab underlayment product 10 for placement on a floor surface of an excavated area prior to in-situ pouring of a concrete slab thereover. The underlayment product 10 features a plurality of solid foam insulation bodies 12 secured to, and preferably encapsulated within, flexible sheeting of appropriate thickness and relative impermeability to serve as an effective barrier against water vapour, air and radon gas. The foam insulation bodies are

preferably composed of recycled expanded polystyrene (colloquially, "styrofoam"), though non-recycled foam material, whether expanded polystyrene or otherwise, could alternatively used. Plastic vapour barrier sheeting made of polyurethane, polyethylene or other polymeric material is known and commercially available, and so particular
5 compositional details thereof are not described herein in further detail. Plastic sheeting of notable thickness may be used to provide a robust, rip-resistant product, particularly since the plastic sheeting bears the weight of the foam insulation bodies secured thereto. The plastic sheeting may have a thickness between 6-mil and 24-mil, and in some embodiments has a thickness greater than 10-mil, preferably between 12-mil and
10 24-mil. Like the foam insulation bodies, the plastic sheeting may be composed partially or fully from recycled materials, and may comprise multiple sheets sealed together to form a laminated sheet of greater thickness than the individual sheets from which it is composed. While the above examples of poly film are commonly used vapour barriers, other polymers, including elastomers (e.g. natural or synthetic rubber), may be
15 used. Likewise, non-polymeric sheeting of suitable impermeability and flexibility may be used in place of polymeric options.

The plastic sheeting includes an upper sheet 14 of elongated rectangular shape that defines a vapour barrier layer that overlies the entire set of solid foam bodies 12, which are arranged in a single-row linear array at the underside of the upper sheet
20 14. The upper sheet 14 has two long edges lying parallel to one another in a longitudinal sheet direction d_{SL} , and two shorter edges lying parallel to one another and perpendicular to the elongated edges in a transverse sheet direction d_{ST} . A length of the sheet L_S is thus measured between the two shorter edges in the longitudinal sheet direction d_{SL} , while a shorter width W_S of the sheet is measured between the two long
25 edges in the transverse sheet direction d_{ST} . The entirety of the upper sheet is a

continuous, unperforated sheet lacking any openings therein.

Each solid foam body 12 is of also of elongated shape, thus having a length L_B that is measured axially of the body and exceeds both a width W_B and thickness T_B of the body. However, the elongated direction of each foam body is oriented perpendicularly transverse to the elongated direction of the upper sheet. Accordingly, the length L_B of each solid foam body is measured in a longitudinal body direction d_{BL} that lies perpendicular to the longitudinal sheet direction d_{SL} and parallel to the transverse sheet direction d_{ST} . The width of each solid foam body W_B is measured in a transverse body direction d_{BT} that lies perpendicularly to the longitudinal body direction d_{BL} and the transverse sheet direction d_{ST} , and parallel to the longitudinal sheet direction d_{SL} . The thickness T_B of each solid foam body 12 is measured in a depth direction d_D that is perpendicular to both the longitudinal and transverse body directions d_{BL} , d_{BT} .

The width W_S of the upper sheet exceeds the length L_B of the equally sized foam bodies, and the set of foam bodies are centered between the long edges of the upper sheet in the transverse sheet direction d_{ST} , whereby the upper sheet 14 overhangs each foam body 12 at both longitudinal ends 12a, 12b thereof. The length L_S of the upper sheet 14 exceeds an overall width W_O of the set of foam bodies 12, as measured longitudinally of the upper sheet from an outer side 12c of a first foam body nearest to a first longitudinal end of the sheet to an outer side 12d of a last foam body nearest to the opposing second longitudinal end of the sheet. In the instance of Figures 1 and 2, where the foam bodies are entirely separate and space from one another, and thus have unoccupied gaps therebetween in the longitudinal sheet direction, this overall width of the set of foam bodies is the sum of the individual widths W_B of the foam bodies, plus the sum of the gap widths between the foam bodies. The set of foam bodies 12

are centered between the short edges of the upper sheet in the longitudinal sheet direction d_{SL} , which together with the excess sheet length relative to the overall body width, means that the upper sheet overhangs the outer sides 12c, 12d of the first and last foam bodies. The upper sheet thus overhangs the set of foam bodies on all sides
5 thereof, whereby the upper sheet features an overhanging outer margin 14a, 14b, 14c, 14d along each of its four perimeter edges. These overhanging outer margins can be used to join together multiple underlayments during installation of the product, as described in more detail further below.

In the preferred embodiment shown in the drawings, the foam bodies are
10 encapsulated within the plastic sheeting. Accordingly, in addition to optional bonding of the topsides of the foam bodies 12 to the underside the upper sheet 14, a lower sheet 16 of the same polymeric sheeting material is attached to the upper sheet 14 in a position spanning beneath the set of the foam bodies 12 in order to encapsulate the foam bodies between the upper and lower sheets 14, 16. In the illustrated example, a
15 singular unitary lower sheet 16 spans fully across the full set of foam bodies in both the longitudinal and transverse sheet directions and is attached to the upper sheet at all four outer margins 14a, 14b, 14c, 14d thereof.

With reference to Figure 2, the lower sheet 16 in the illustrated example is also attached to the upper sheet 14 in the gaps between the separate foam bodies
20 12 so that the lower sheet wraps upwardly between the foam bodies to maintain the gaps as open drainage spaces 18 in the final installation of the underlayment, as described in more detail below. Each attachment of the lower sheet 16 to the upper sheet 14 at the outer margins of the upper sheet and at the gaps between the foam bodies may be accomplished by heat sealing of the upper and lower sheets 14, 16 to
25 one another, whether using radio frequency welding, ultrasonic welding, or other heat-

sealing techniques, for example depending on the material composition of the sheeting. Rather than direct bonding through a heat welded seam, the sheets may be attached together by a separate adhesive product, for example a flowable glue adhesive or rolled tape adhesive, the latter of which may be a peel-and-stick adhesive tape with a single-
5 sided or double-sided adhesive strip whose one or more adhesive sides are initially covered by one or more respective protective strips.

As an alternative to a singular unitary lower sheet 16 spanning the entire set of foam bodies, smaller lower sheets each encapsulating a respective subset of the foam bodies may be employed. In one such example, individual lower sheets each
10 encapsulate a respective one of said foam bodies. The foam bodies may be secured to the plastic sheeting solely by the encapsulated state thereof between the upper and lower plastic sheets, or may feature additional bonding of the foam bodies to the sheeting itself by a suitable bonding agent. In other embodiments, encapsulation of the foam bodies by one or more lower sheets may be omitted, with the foam bodies being
15 held in place solely by bonded connection to the upper sheet. In the illustrated embodiment, the polymeric sheeting is transparent or translucent, hence the visibility of the foam bodies through the upper and lower sheets in the drawings.

Figures 2 and 3 show the foam bodies as having circular cross-sectional shape in planes lying normal to the longitudinal body direction d_{BL} , but it will be
20 appreciated that any variety of cross-sectional shapes may be employed. The variants in Figures 4 and 5 illustrates two such variants, which also demonstrate that the foam bodies need not be entirely separate and spaced apart entities.

Instead, two or more adjacent foam bodies may be integral sections of a larger solid foam unit, as demonstrated by the Figure 4 underlayment 10' in which the
25 full set of foam bodies 12' are all integrally defined by a singular, monolithic foam unit

encapsulated in, and/or bonded to, the plastic sheeting. Here, each foam body 12' is downwardly tapered in width over at least a portion of its thickness so that lower ends 12e of the foam bodies lying furthest from the upper sheet 14 are narrower than the top ends of the foam bodies that directly underlie the upper sheet in adjacent or bonded
5 relation thereto. This way, a gap space is still left between each adjacent pair of foam bodies at the tapered regions 12f and narrowed lower ends 12e thereof to create the aforementioned drainage space 18. Meanwhile, the wider upper ends of the foam bodies 12' are integrally joined to one another at the underside of the upper sheet 14, thus bridging the foam bodies together as a monolithic unit.

10 Figure 5 illustrates another variant of the underlayment 10'' where the foam bodies 12'' are again tapered to define narrowed lower ends at which the gap spaces reside to create the drainage spaces 18 between the foam bodies, like in Figure 4. However, in Figure 5, the foam bodies are separate individual foam bodies rather than part of a larger monolithic unit like that of Figure 4. However, unlike the separately
15 spaced foam bodies in Figures 1 and 2, the wider upper ends of the foam bodies 12'' in Figure 5 reside in abutted contact with one another at the underside of the upper sheet. In the Figure 5 variant, the top ends of the foam bodies 12'' thus occupy the entire central non-margin area of the upper sheet 14 to maximize the load bearing upper surface area of the underlayment, whereas in Figure 1, the gaps span all the way from
20 the lower ends of the foam bodies to the underside of the upper sheet, thus leaving non-load-bearing strips of upper sheet's central area unsupported at the gaps between the foam bodies.

Regardless of the cross-sectional shape of the foam bodies 12 and whether they are separately individual bodies or part of a larger monolithic foam unit,
25 each foam body 12 is preferably longer at the bottom end 12e thereof than at the top

end thereof. This is shown in Figure 6, where the longitudinal ends 12a, 12b of each foam body 12 slope downwardly inward in converging fashion to impart a downward taper to the length dimension of the body. This helps ensure that when two underlayments are laid down side by side along the long edges of their upper sheets as shown in Figure 8, and then joined together at the longitudinal margins 14a, 14b running along these edges, as shown in Figure 9, a guaranteed drainage space 20 will be left open between the foam bodies of the two underlayments at the shorter lower ends 12e of the foam bodies, even if the longer top ends of the foam bodies are placed in abutting relation during the placement and seaming together of the underlayments.

10 The flexible upper sheet 14 of the underlayment product allows it to be folded or rolled up in the longitudinal sheet direction into a reduced footprint for transport and storage. Figures 1 through 6 show a strip of underlayment having five foam bodies, but the quantity of foam bodies per strip may be varied. For example, the underlayment may be manufactured with a substantial sheet length and substantial quantity of foam bodies thereon, which is then rolled up into a relatively large coil. Later, a distributor, retailer or end-user may unroll the coiled product, and cut the upper sheet in the transverse sheet direction at select intervals to create smaller underlayments strips of reduced foam body count. In the Figure 4 example, the bridged connections between the integrally defined foam bodies of the monolithic foam unit may be kept relatively thin an flexible to allow temporary folding or rolling of the underlayment for transport and storage before use.

20 Figure 7 illustrates how underlayments are used during construction of a concrete foundation of a building. First, a site is excavated and concrete footings 30 are laid out around the perimeter of an earthen bottom floor 32a of the excavation area, over which for the intended concrete slab is destined. A sump pit 34 is installed in

recessed relation to the earthen floor, along with any plumbing or ventilation rough-ins required to service the building. Though the figure shows the sump pit at a center point of the floor surface, the invention is not limited to such central sump placement. One ventilation exhaust rough-in 38 is shown standing upright from the sump pit 34 for
5 reasons described herein further below. The earthen floor is then graded to provide a gradual even slope downwardly from the footed perimeter of the earthen floor surface to the sump pit in all direction. Crushed rock is spread over the earthen floor and then graded, as shown in Figure 7, or leveled, as shown in Figure 7A, to form a finished floor surface of the excavated area over which a concrete slab is to be poured. This crushed
10 rock floor surface 32b is then compacted with a plate tamper. With the floor surface 32b now ready for placement of the underlayment, the upright concrete walls 36 of the foundation can be poured in suitable forms (not shown) erected atop the footings 30.

Once the foundation walls are complete, the floor surface 32b is overlaid with a suitable number of underlayments to fully occupy the entire floor surface. In one
15 embodiment, the differently sized underlayments of varying thickness are produced, whereby the end-user can acquire a group of underlayments among which some have thicker foam bodies than others. The different thicknesses can be used to compensate for the slope of the floor surface 32b toward the sump pit 34 in the event that a level concrete slab is desired atop the sloped floors surface. Figure 7 illustrates an example
20 where underlayments of three different thicknesses are used, and are laid out in series of increasing thickness from the outer footings 30 toward the sump pit 34.

For example, on a sloped floor that's 4-inches higher at the footings 30 than at the sump pit 34, one could use using 8-inch thick underlayments at outer regions of the floor surface adjacent the footings 30, 10-inch thick underlayments at mid regions
25 of the floor surface situated intermediately between the footings 30 and the sump pit

34, and 12-inch thick underlayments at inner regions of the floor surface 32b adjacent the sump pit 34. In this example, the four-inch rise of the sloped floor surface 32b is compensated for by the 4-inch difference in thickness between the 8-inch outer underlayments near the footings and the 12-inch underlayments near the sump pit 34.

- 5 This minimizes the elevational offset between the upper sheets of the different underlayments to provide a generally level surface for the concrete slab to be poured over.

On the other hand, if its desirable to slope the concrete at the same angle as the floor surface, then the same thickness of underlayment may be used throughout.

- 10 Alternatively, multiple underlayment thicknesses may be employed where the thickness difference between the outer underlayments adjacent the footings and inner underlayments adjacent the sump pit may be different than the rise of the sloped floor surface to only partially compensate the floor surface slope, thus providing the concrete slab with some degree of slope, but less than the slope of the floor surface. In other
- 15 instances, where the crushed rock of the floor surface is level rather than at a graded slope, the same uniform underlayment thicknesses can be used throughout. Figure 7A shows another example, where the same uniform thickness of underlayment is used throughout the excavated area in an example where the earthen floor 32a is once again graded to slope downwardly toward the sump pit, but the crushed rock is laid in a non-
- 20 uniform thickness so that the top floor surface 32b of this crushed rock layer is horizontally level.

- When laying down the underlayments, care should first to be taken to ensure that the floor surface is relatively flat and free of notable irregularities. Next, from an initially rolled quantity of underlayment, a first strip is unrolled across a
- 25 perimeter-adjacent outer region of the floor surface from the footing at one end of this

region to the opposite footing at the other end of this region. Next, a second strip is unrolled across the floor surface in the same direction and in adjacent parallel relation to the first strip of underlayment. This second strip may likewise span fully across the floor surface from footing to footing if the same underlayment thickness is desired at
5 the second floor region over which the second strip is being laid. Alternatively, the second strip may span only partly across the second floor region if varying underlayment thickness is required thereacross according to the particular grade or slope of the floor surface and the desired concrete slab.

During this placement of the second strip of underlayment, the
10 overhanging longitudinal margins 14a, 14b of the two underlayment strips are placed in overlapping relation to one another, as shown in Figure 8. As shown in Figure 9, the long edges of the upper sheets of the two underlayment strips running along these overlapping margins 14a, 14b are then lifted up and pinched together to enable the margins 14a, 14b of the two underlayment strips to be sealed together to create a fluid
15 tight seam between the upper sheets thereof. The degree of overlap between the margins and the placement of the seal are selected to preferably maintain a space between the ends 12a, 12b of the foam bodies of the two underlayment strips, even at the longer top ends thereof, though as mentioned above the lengthwise taper of the foam bodies ensures the creation of drainage space 20 between the foam bodies of the
20 seamed-together underlayment strips at least at the lower ends 12e thereof. Figure 9 also illustrates the sloping of the floor surface 32b downwardly toward the sump pit, and how the different thickness of the sealed-together underlayment strips compensates for this floor slope to place the upper sheets 14 of the two underlayment strips at roughly equal elevation despite seating of the underlayment strips on floor areas of different
25 elevation.

The sealing together of the strips may performed by heat sealing, whether using radio frequency welding, ultrasonic welding, or other heat-sealing techniques, for example depending on the material composition of the sheeting. Rather than direct bonding through a heat welded seam, the sheets may be seamed together by a
5 separate adhesive product, for example a flowable glue/sealant product or rolled tape product, the latter of which may be a peel-and-stick adhesive tape. Accordingly, reference herein to sealed or seamed connection is not limited to heat welded seams.

Such laying of the underlayment strips in overlap with one another and seaming together of the overlapping margins is repeated until the entire floor surface
10 32b is covered, during which holes can be cut through the upper sheet 14 and bores or pieces can be cut through or from the foam bodies 12 wherever necessary to accommodate the rough-ins that sand upright from the floor surface. The upper sheet is sealed to any such rough-in around a full perimeter thereof, for example with a flowable sealant product (e.g. acoustical sealant) or rolled tape product. For any two
15 underlayments laid longitudinally end to end, like those of Figure 7, as opposed to transversely side by side like those of Figures 8 and 9, the same overlapping of upper sheet margins and seaming together of such sheet margins is performed between the underlayment strips, but at the transverse margins 14c, 14d running along the shorter edges of the upper sheets at the longitudinal ends of the underlayments. The degree
20 of overlap between the margins 14c, 14d of the two underlayments is again selected to maintain spacing between the foam bodies that border these margins of the two underlayments to leave another drainage space therebetween. Once the entire floor surface 32b is covered between the footings 30, and the margins of all the underlayments have been sealed together so that their upper sheets provide a
25 continuous unperforated layer of vapour barrier sheeting over the entire floor surface,

the outer perimeter of this collective sheet is sealed to the concrete footings 30 around the perimeter of the floor surface, for example using a bead of flowable glue/sealant product (e.g. acoustical sealant), a single-sided or double-sided tape product (whether peel-and-stick or otherwise), or a combination thereof.

5 Once the seams between the underlayments and the seals around the rough-ins have been inspected to ensure their integrity against vapour or gas intrusion, a cover layer 40 of greater rigidity than the plastic sheeting and foam bodies of the underlayments is laid atop the collective upper sheet of the seamed-together underlayments. This cover layer may comprise hardboard or OSB sheeting, or other
10 relatively rigid sheets or panels. This more rigid cover layer helps evenly distribute the load of the concrete slab, once poured, over the floor-seated foam bodies of the underlayments. The concrete slab 42 is then poured atop the rigid cover layer 40, thus achieving a finished state of the foundation.

 The collective sheet formed by the sealed-together upper sheets of the
15 underlayments forms a vapour, air and radon barrier over an entirety of the earthen area beneath the concrete slab. With the foam bodies seated on the floor surface, the drainage spaces 18 left between the foam bodies in the longitudinal sheet direction and the drainage spaces 20 left between the foam bodies in the transverse sheet direction create drainage channels running along the top of the floor surface 32b in both the
20 transverse and longitudinal sheet directions, respectively. Accordingly, any water accumulating under the concrete pad 42 can flow in two dimensions into the sump pit 34, as shown with flow arrows in Figure 8. The foam bodies 12 not only support the slab 42 in spaced relation above the floor to maintain these drainage spaces, but also serve as void forms to accommodate earthen swelling beneath the concrete slab, and
25 also as thermal insulators that inhibit heat transfer between the concrete slab and the

ground beneath. In non-limiting examples, the foam bodies may have thicknesses measuring between 2-inches and 12-inches, inclusive; lengths measuring 4-feet to 12-feet, inclusive; an insulation rating of between R10 and R40, inclusive; and a compressive strength measuring between 2 PSI and 50 PSI inclusive.

5 Referring to Figure 7, the ventilation exhaust rough-in 38 protruding up from the finished concrete slab 42 is coupled to the bottom end of a ventilation stack pipe 44 that runs up to the roof of a building, where it exhausts through a screened outlet under the protection of a sealed rain cap 46. The bottom end 38a of the ventilation exhaust rough-in 38 resides in an air space defined below the collective
10 vapour barrier sheet by the network of fluidly connected drainage channels and the sump pit into which they drain. Accordingly, operation of a fan 48 cooperatively installed with the ventilation stack pipe 44 is operable to induce low pressure conditions in this airspace below the concrete. Accordingly, any radon gas emitted from the soil beneath the concrete slab is contained by the collective upper sheet of the installed
15 underlayments to prevent entry of the radon gas into the interior space of the building, while the fan safely exhausts such radon gas to the ambient outdoor environment. While the illustrated embodiment uses a vertical stack pipe and rooftop outlet, the particular routing and final exit point of this ventilation line may be varied within the scope of the present invention.

20 In addition to the ventilation exhaust rough-in 38 through which radon gas is exhausted, the rough-ins may include ventilation inlet rough-ins 50 whose lower ends likewise reside in the air space defined below the collective vapour barrier sheet, but whose upper ends open into the interior space of the building above the concrete slab. Either prior to their installation or thereafter, these ventilation inlet rough-ins 50 are
25 equipped with one-way check valves allowing downflow through these rough-ins 50 ,

but preventing upflow therethrough. Radon gas can thus not flow upwardly into the interior space of the building, but indoor air from the interior space of building can be drawn down into the air space below the concrete slab when sufficient pressure reduction is induced therein by operation of the fan 48 in the ventilation stack 44. In the illustrated example, the ventilation inlet rough-ins 50 are situated near the outer perimeter of the floor area near the footings, for example near outer corners of the concrete slab, so that the indoor air induced into the air space flows inwardly toward the more centrally located ventilation exhaust rough-in 38 and connected ventilation stack 44. However, it will be appreciated that the particular placement of the check-valved inlet rough-ins 50 may vary relative to the building footprint and the ventilation stack.

The underlayment product may be referred to as a VADIR barrier, of which the acronym denotes the multi-function capabilities of the product: Void form, Air barrier, Drainage creation, Insulation and Radon protection. An acronym is VIPAR: Void form, Insulation, Poly barrier, Aquatic drainage, and Radon protection. All such functions are achieved through laying out of a singular underlayment product over the earthen floor of the excavated area, thus notably reducing the labour requirements compared to conventional foundation preparation methodologies. Placement of each individual strip of underlayment automatically places a plurality of foam void forms in adjacent or appropriately spaced relation to create open drainage channels between the bottom ends of the void forms, while simultaneously laying down a vapour/air/radon barrier in the form of the product's upper sheet. Meanwhile, the flexible upper sheet of the product allows compact storage and transport thereof in rolled or folded form, for easy placement of the strips by unrolling or unfolding of same across the floor surface. Through preferable use of recycled foam, the environmental impact of the product is

also reduced compared to non-recycled polystyrene void forms of the prior art, while avoiding the premature degradation pitfalls of cardboard void forms.

Figure 10 shows an alternative to the first embodiment underlayments of Figures 1 through 6. In this alternate embodiment of the underlayment 110, instead of being composed solely of flexible vapour barrier sheeting that enables rolled-up storage and transport of the underlayment, the upper vapour barrier layer instead has a composite construction formed by a relatively rigid primary upper sheet 114 and a series of flexible perimeter flaps 115a, 115b, 115c, 115d affixed to the primary upper sheet 114 in a manner spanning fully around the outer perimeter thereof in overhanging relation therefrom. These flexible perimeter flaps comprise the same substantially impermeable plastic sheeting or other material as the upper sheet 14 of the first embodiment, and thus define the same flexible, overhanging outer margins by which multiple underlayments can be overlapped and sealed together during installation, as described above for the first embodiment where such flexible outer margins are seamlessly integral parts of the same flexible sheeting overlying the foam insulation bodies 112. Like with the first embodiment, one or more lower sheets 116 preferably encapsulate the foam insulation bodies in a manner wrapping around the lower ends thereof and tucking up into sealed connection with the upper vapour barrier layer, in this case at the underside of the primary upper sheet 114, at the top ends of the drainage spaces 118.

The primary upper sheet 114 in the alternate embodiment is more rigid than the plastic sheeting or material used for the perimeter flaps 115, but is likewise substantially impermeable to gas and vapour, just like the more flexible plastic sheeting of the perimeter flaps. In one non-limiting example, the primary sheet 114 may be a sheet of puckboard (High Density Poly Ethylene, or HDPE) or other rigid or semi-rigid

plastic, and may measure between 2 x 2 feet and 6 x 12 feet, for example measuring 4 x 8 feet in one particular instance. Use of puckboard or other non-porous, impermeable rigid sheeting serves the dual-purpose of replacing the vapour barrier functionality of the flexible upper sheet of the first embodiment, and also replacing the concrete load-distributing functionality of the separate cover 40 installed atop the underlayments in the first embodiment. The relatively rigid primary sheet of the second embodiment thus avoids the need to install a separate cover layer after placing the underlayments over the floor surface, while the flexible perimeter flaps still enable the same adjustable overlap and seamed-together attachment of the underlayments during installation.

10 While the relatively rigid primary sheet 114 in the alternate embodiment prevents rolled storage and transport, Figure 12 illustrates how the sizing, shape and relative spacing of the foam insulation bodies 112 may be selected to enable intermeshed stacking of two matching underlayments, thereby minimizing the stacked height of two or more underlayments in storage or transport. In the illustrated example, 15 the drainage spaces 118 between the foam insulation bodies 112 are of similar size and shape, but inverted orientation, relative to the foam insulation bodies themselves. Accordingly, as shown in Figure 12, a first underlayment can be laid out in an inverted (upside-down) orientation facing its foam insulation bodies upward so that a second underlayment can be laid atop the first in a non-inverted (right-side-up) orientation in a 20 position longitudinally offset from the first underlayment by one body width W_B so that the downwardly protruding foam insulation bodies of the second underlayment are received in intermeshing relation between the foam insulation bodies of the first underlayment. In this invertedly and intermeshingly stacked relationship of the two underlayments, where the foam insulation bodies of each underlayment point toward 25 the rigid primary sheet of the other underlayment inside the drainage spaces of that

other underlayment, the distance between the primary sheets 114 of the two underlayment is minimized to the keep the stacked height thereof to a minimum.

It will be appreciated that the same use of intermeshably shaped foam insulation bodies may be employed for space efficient stacking of underlayments regardless of whether the upper vapour barrier layer of the underlayments includes a
5 relatively rigid primary sheet, like that of the second embodiment, or features a flexible sheet composition throughout, like that of the first embodiment. The flexible outer flaps in the second embodiment may be narrow strip-like flaps individually attached and sealed to the primary upper sheet 114 along the respective perimeter edges thereof,
10 and then sealed together at the corners of the primary upper sheet to ensure a gas and vapour tight state throughout to entire area of the resulting composite vapour barrier layer. Alternatively, the flaps may be integral parts of a unitary flexible sheet that overlies or underlies the more rigid primary sheet 114, and exceeds the size of the primary sheet 114 so as to overhang therefrom on all perimeter sides thereof to define
15 the flexible outer margins by which the underlayment can be sealed to another such underlayment.

Since various modifications can be made in my invention as herein above described, and many apparently widely different embodiments of same made, it is intended that all matter contained in the accompanying specification shall be interpreted
20 as illustrative only and not in a limiting sense.

CLAIMS:

1. A concrete slab underlayment for use at an area at which an in-situ concrete slab is to be poured, said underlayment comprising:

an upper vapour barrier layer comprising at least one material that is
5 substantially impermeable to gas and vapour; and

a set of insulation bodies that are materially distinct from the at least one material of the upper vapour barrier layer, and are secured to said upper vapour barrier layer in underlying relation thereto at a central non-margin area thereof;

wherein said upper vapour barrier layer spans fully over all of said
10 insulation bodies, said insulation bodies are spaced apart from one another at least at lower ends thereof opposite the upper vapour barrier layer to leave drainage/air spaces open between the lower ends of said insulation bodies when laid in an installed position atop a floor surface of said area; and

wherein said at least one material of the upper vapour barrier layer
15 comprises flexible sheeting, at least at outer margins of said upper vapour barrier layer that reside along respective perimeter edges of the vapour barrier layer outside the central non-margin area occupied by the insulation bodies;

whereby in use in said installed position under a concrete slab poured
20 over said underlayment, the vapour barrier layer forms a gas and moisture barrier beneath said concrete slab, and the insulation bodies and the drainage/air spaces therebetween form a combination of void spaces, drainage channels and insulation blocks between said floor surface and said concrete slab.

2. The underlayment of claim 1 wherein the insulation bodies are
25 encapsulated between said vapour barrier layer and at least one flexible lower sheet wrapped about the lower ends of said insulation bodies.

3. The underlayment of claim 1 or 2 wherein each insulation body is elongated in a longitudinal body direction.

4. The underlayment of claim 3 wherein the upper vapour barrier layer is elongated in a direction of elongation, and the longitudinal body direction lies
5 transversely of said direction of elongation.

5. The underlayment of claim 4 wherein a length dimension of the upper vapour barrier layer measured in the direction of elongation exceeds an overall width of the set of insulation bodies measured in said direction of elongation.

6. The underlayment of claim 5 wherein two of the outer margins of
10 the upper vapour barrier layer reside outside the central non-margin area at opposite ends thereof in the direction of elongation.

7. The underlayment of any one of claims 3 to 5 wherein a width dimension of the upper vapour barrier layer in the longitudinal body direction exceeds a length dimension of each insulation body in said longitudinal body direction.

8. The underlayment of claim 7 wherein two of the outer margins of
15 the upper vapour barrier layer reside outside the central non-margin area at opposite sides thereof in the longitudinal body direction.

9. The underlayment of any one of claims 3 to 8 wherein the insulation bodies are spaced apart from one another at said lower ends thereof in a
20 transverse body direction perpendicular to said longitudinal body direction.

10. The underlayment of any one of claims 1 to 9 wherein the outer margins of the upper vapour barrier layer surround the central non-margin area thereof on all sides.

11. The underlayment of any one of claims 1 to 10 wherein the set of
25 insulation bodies consists of a singular row of said insulation bodies.

12. The underlayment of any one of claims 1 to 11 wherein said insulation bodies comprise foam.

13. The underlayment of any one of claims 1 to 12 wherein the drainage/air spaces between the insulation bodies are sized and shaped to accommodate receipt of the insulation bodies of a matching underlayment.

14. The underlayment of any one of claims 1 to 13 wherein the vapour barrier layer comprises a primary upper sheet that has greater rigidity than the flexible sheeting and occupies the central non-margin area at which the insulation bodies are secured, and a set of flexible perimeter flaps that are formed of said flexible sheeting, are attached to the primary upper sheet, and span in overhanging relation therefrom around a perimeter thereof at said outer margins of said vapour barrier layer.

15. The underlayment of any one of claims 1 to 13 wherein the upper vapour barrier consists substantially entirely of said flexible sheeting.

16. The underlayment of any one of claims 1 to 13 and 15 in an installed condition atop said floor surface and in combination with a cover layer placed thereon, wherein the cover layer is more rigid than said flexible sheeting of the upper vapour barrier layer and resides in overlying relation to the upper vapour barrier layer and the insulation bodies therebeneath.

17. The underlayment of claim 16 wherein the cover layer comprises wooden sheets or panels.

18. The underlayment of any one of claims 1 to 15 in an installed condition atop said floor surface, and in combination with a sump pit recessed below said floor surface and toward which water flow is gravitationally encouraged via the drainage spaces between the insulation bodies of the underlayment.

19. The underlayment of any one of claims 1 to 15 in an installed

condition atop said floor surface, wherein the drainage spaces communicate with one another to collectively form an air space between the floor surface and the underlayment, and a ventilation pipe communicates with said air space to exhaust gases therefrom.

5 20. The underlayment of any one of claims 1 to 19 in a finished state residing atop said floor surface in underlying relation to the concrete slab once poured over said underlayment, wherein below said concrete slab, the vapour barrier layer defines said gas and moisture barrier, and the insulation bodies and the drainage/air spaces therebetween form said combination of void spaces, drainage channels and
10 insulation blocks between said floor surface and said concrete slab.

 21. A plurality of underlayments according to any one of claims 1 to 15 in an installed condition atop said floor surface, wherein the said plurality of underlayments are sealed together with one another at the outer margins of the vapour barrier layers thereof to form a gapless span of said vapour barrier layers across said
15 floor surface.

 22. The plurality of underlayments of claim 21, wherein the vapour barrier layers are sealed together by heat welded seams.

 23. A plurality of underlayments according to any one of claims 1 to 15, wherein said plurality of underlayments comprise differently dimensioned
20 underlayments among which a thickness dimension of the insulation bodies measured from the lower ends thereof to the vapour barrier layer varies from one underlayment to another, whereby placement of said differently dimensioned underlayments next one another atop a sloped floor surface in order of decreasing thickness from a lower elevation on said sloped floor surface toward a higher elevation on said sloped floor
25 surface is effective to reduce elevational offset between the vapour barrier layers of

said underlayments due to said sloped floor surface.

24. The underlayments of claim 23 in an installed condition atop said sloped floor surface in said order of decreasing thickness from said lower elevation on said sloped floor surface to said higher elevation on said sloped floor surface.

5 25. The underlayments of any one of claims 21 to 24 in combination with a cover layer placed atop said underlayments in overlying relation to the vapour barrier layer and the insulation bodies beneath said vapour barrier layer, said cover layer being of greater rigidity than the flexible sheeting of said vapour barrier layer.

10 26. The underlayment of claim 25 wherein the cover layer comprises wooden sheets or panels.

15 27. The underlayments of any one of claims 21 to 26 in a finished state residing atop said floor surface in underlying relation to a concrete slab poured over said underlayments, wherein below said concrete slab, the vapour barrier layer defines said gas and moisture barrier, and the insulation bodies and the drainage/air spaces therebetween form said combination of void spaces, drainage channels and insulation blocks between said floor surface and said concrete slab.

20 28. A plurality of underlayments according to any one of claims 1 to 15 wherein, wherein said plurality of underlayments comprise first and second underlayments in which the drainage/air spaces of each underlayment are sized and shaped to accommodate receipt of the insulation bodies of the other underlayment to enable storage of said first and second underlayments in intermeshingly and invertedly stacked relation.

29. A method of preparing an area for an in-situ concrete slab, said method comprising:

25 (a) atop a floor surface of said area, laying down a plurality underlayments

of the type recited in any one of claims 1 to 15; and

(b) sealing together the vapour barrier layers of said plurality of underlayments at the outer margins thereof to create a gapless span of said vapour barrier layers across said floor surface.

5 30. The method of claim 29 further comprising placing covering sheets atop said plurality of underlayments, said covering sheets being of greater rigidity than the flexible sheeting of said vapour barrier layers.

 31. The method of claim 29 or 30 comprising pouring said in-situ concrete slab over said plurality of underlayments.

10 32. The method of any one of claims 29 to 31 wherein said floor surface is sloped, the plurality of underlayments comprise differently dimensioned underlayments among which a thickness dimension of the insulation bodies measured from the lower ends thereof to the vapour barrier layer varies from one underlayment to another, and step (a) comprises laying said differently dimensioned underlayments
15 in order of decreasing thickness from a lower elevation on said sloped floor surface toward a higher elevation thereon.

 33. The method of claim 32 wherein a sump pit is recessed below said floor surface, and step (a) comprises laying said differently dimensioned underlayments in said order of decreasing thickness away from the sump pit.

20 34. The method of any one of claims 29 to 33 comprising, before pouring said in-situ concrete slab, erecting a ventilation rough-in from an air space in which the drainage spaces communicate with one another below the vapour barrier layer to enable ventilation of gases from beneath said concrete slab via said ventilation rough-in.

25

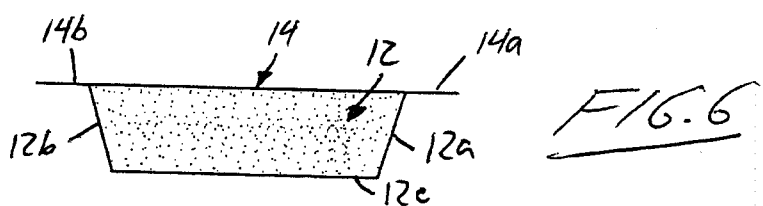
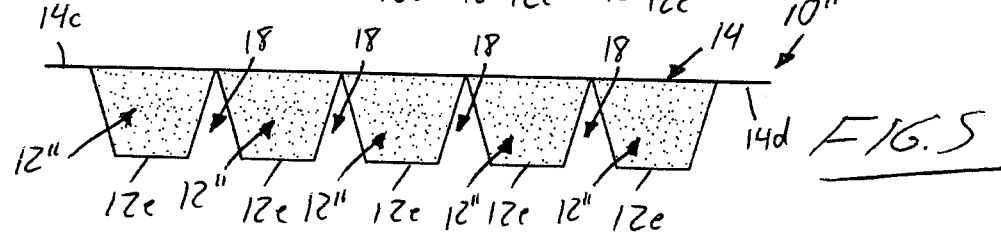
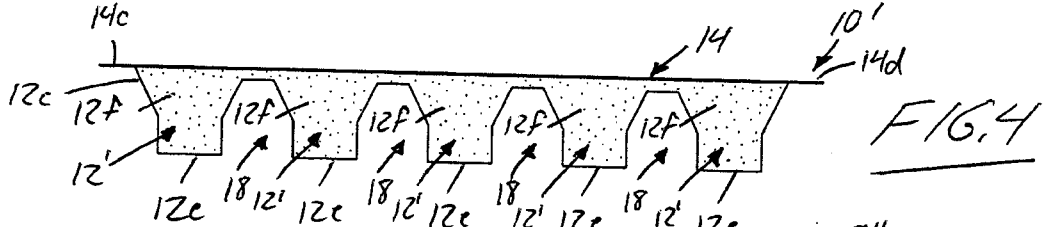
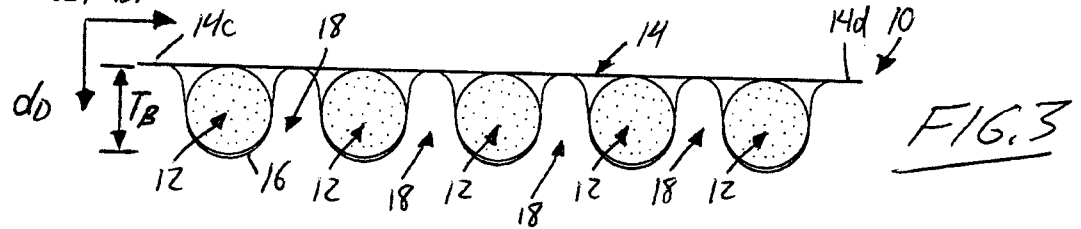
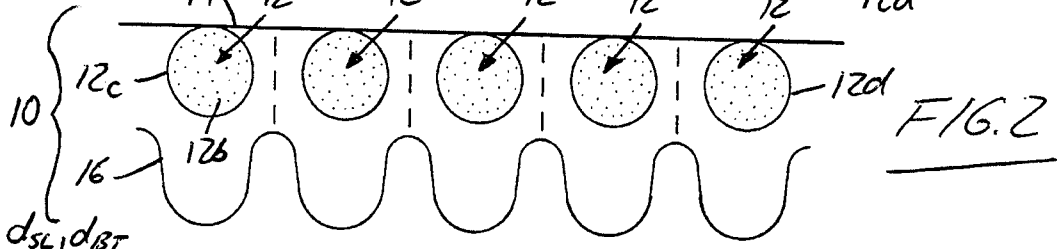
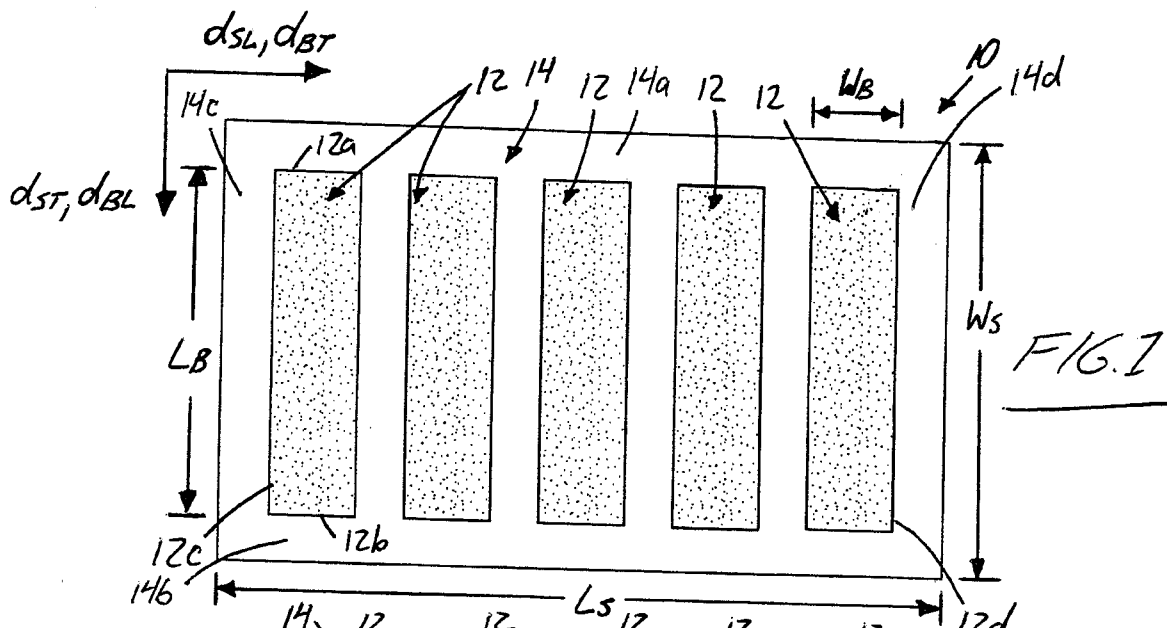

FIG. 7

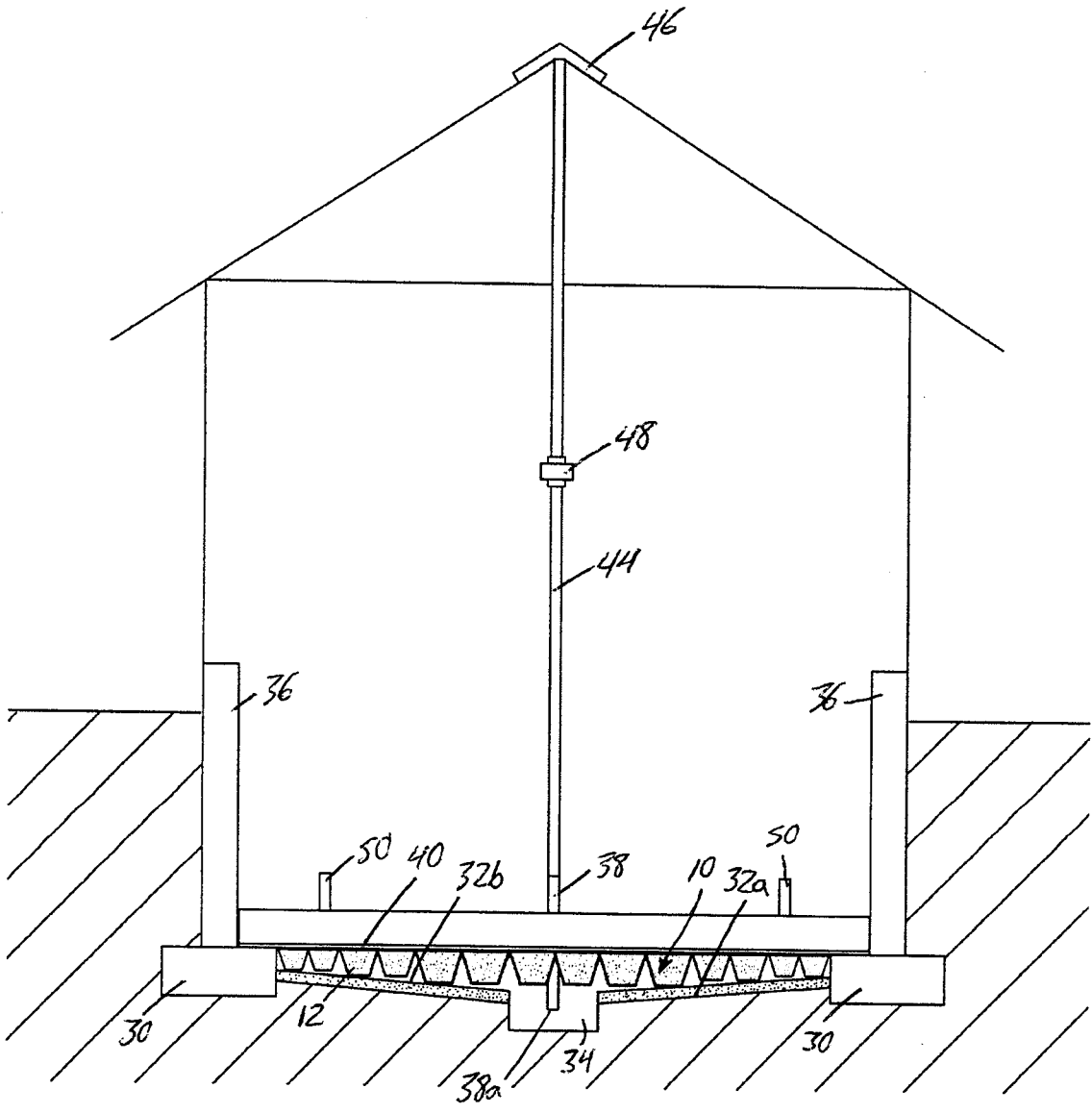
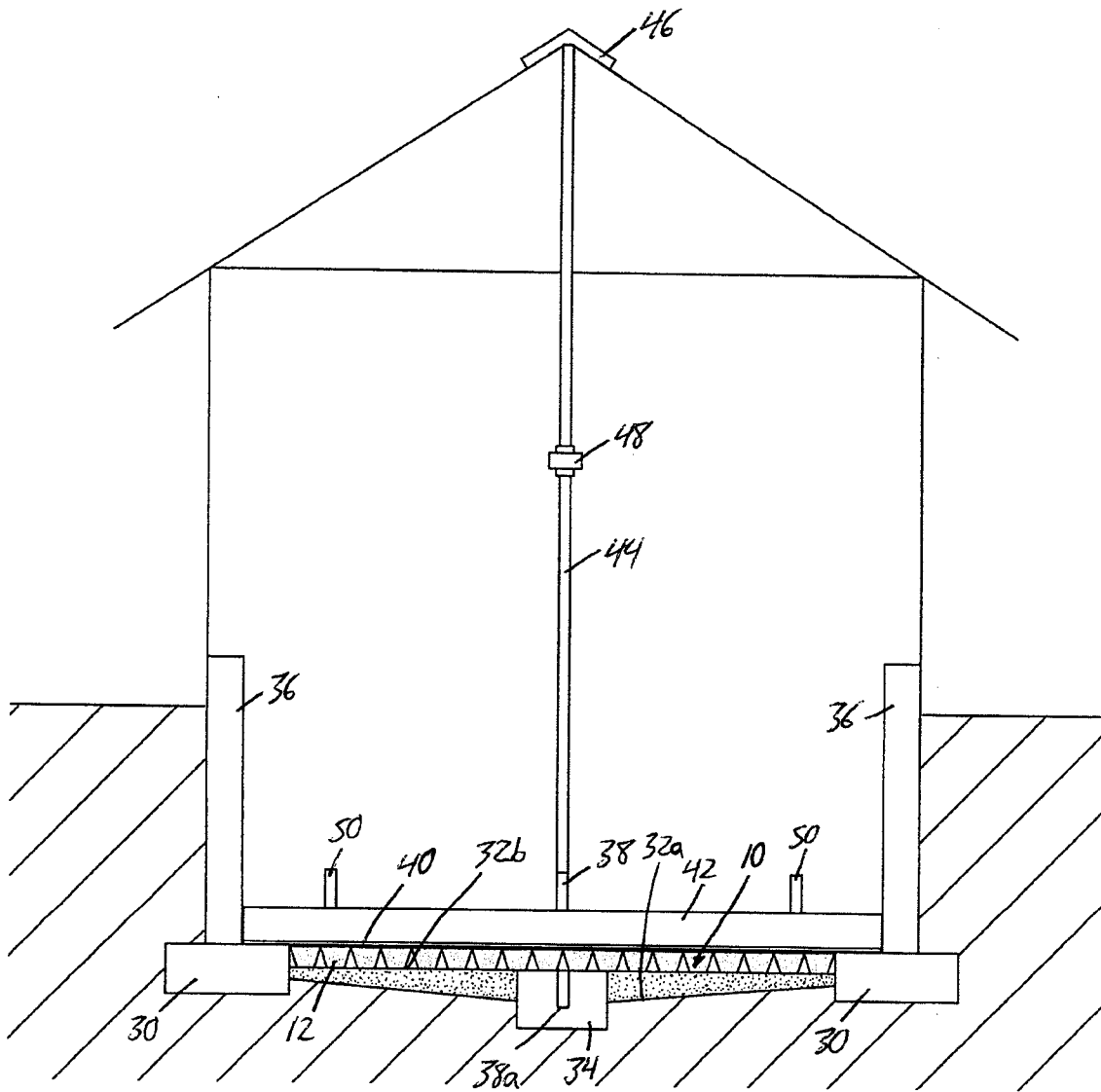

FIG. 7A



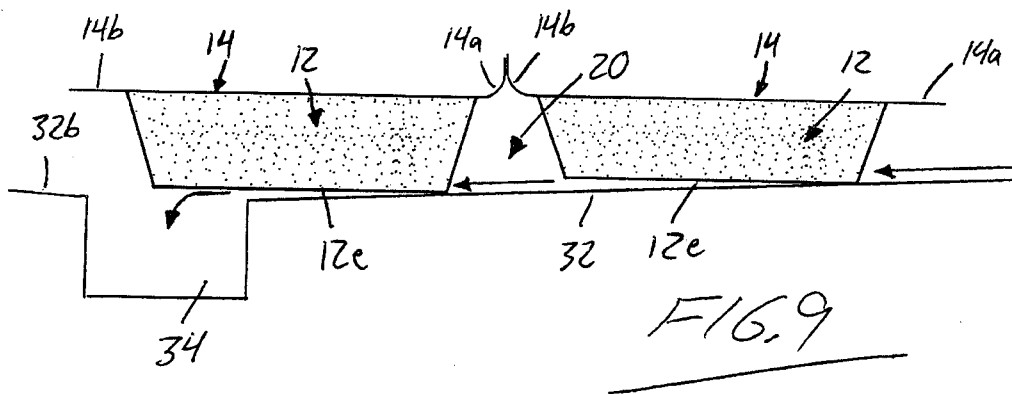
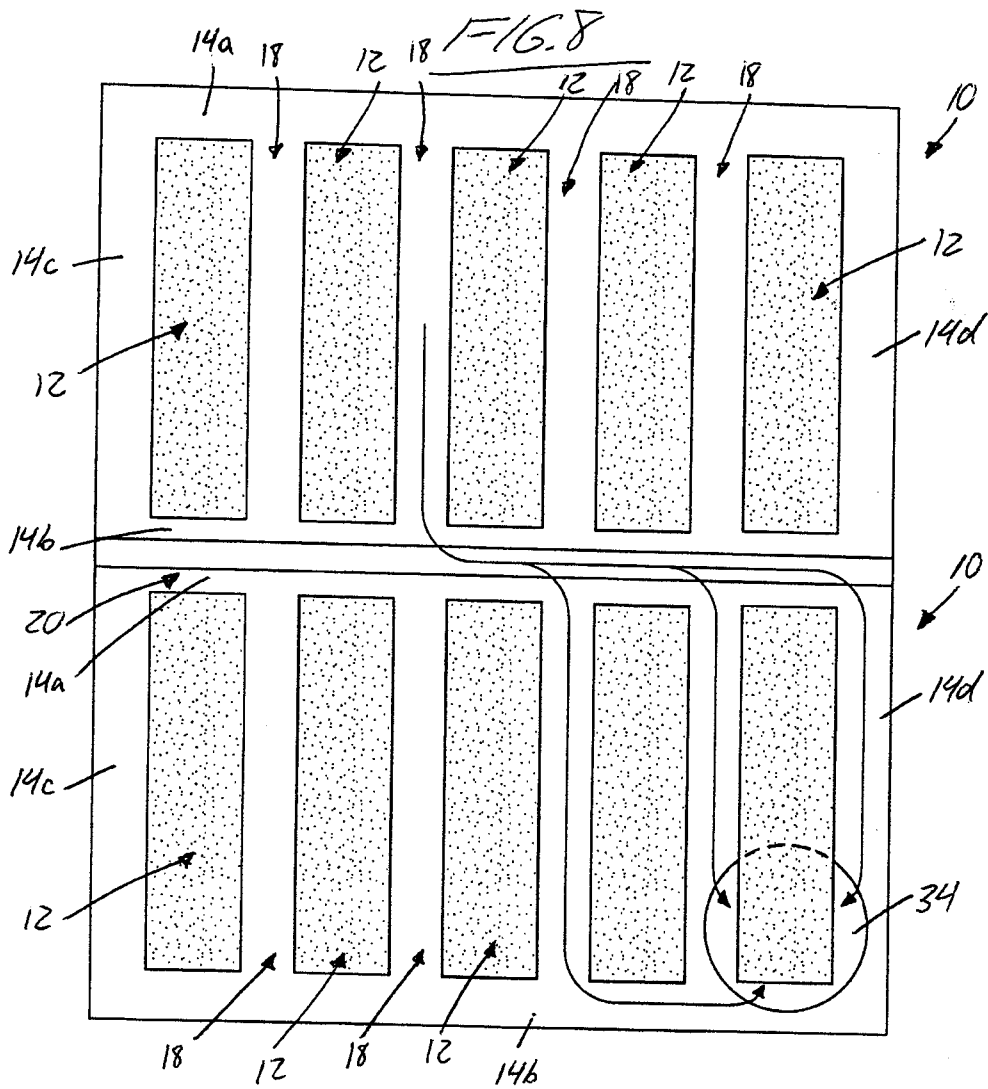

FIG. 10

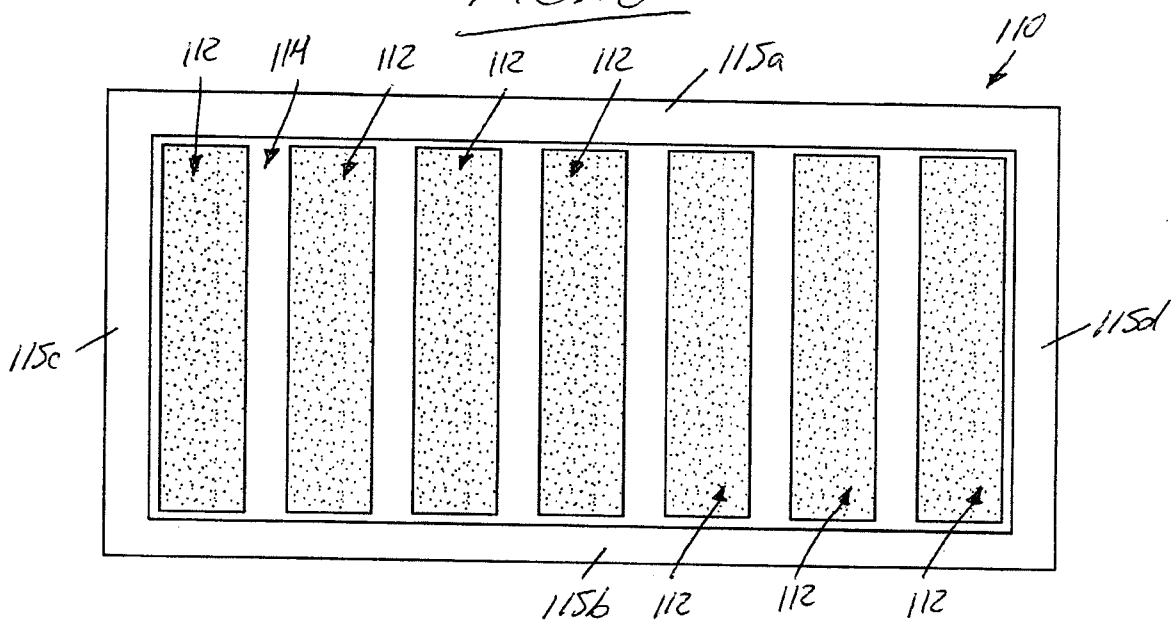

FIG. 11

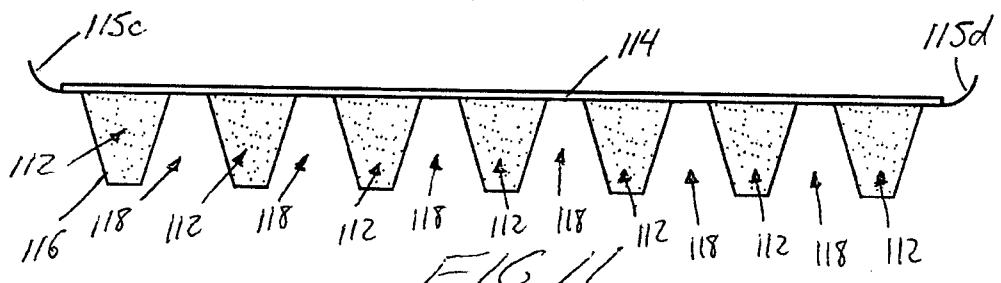

FIG. 12

