

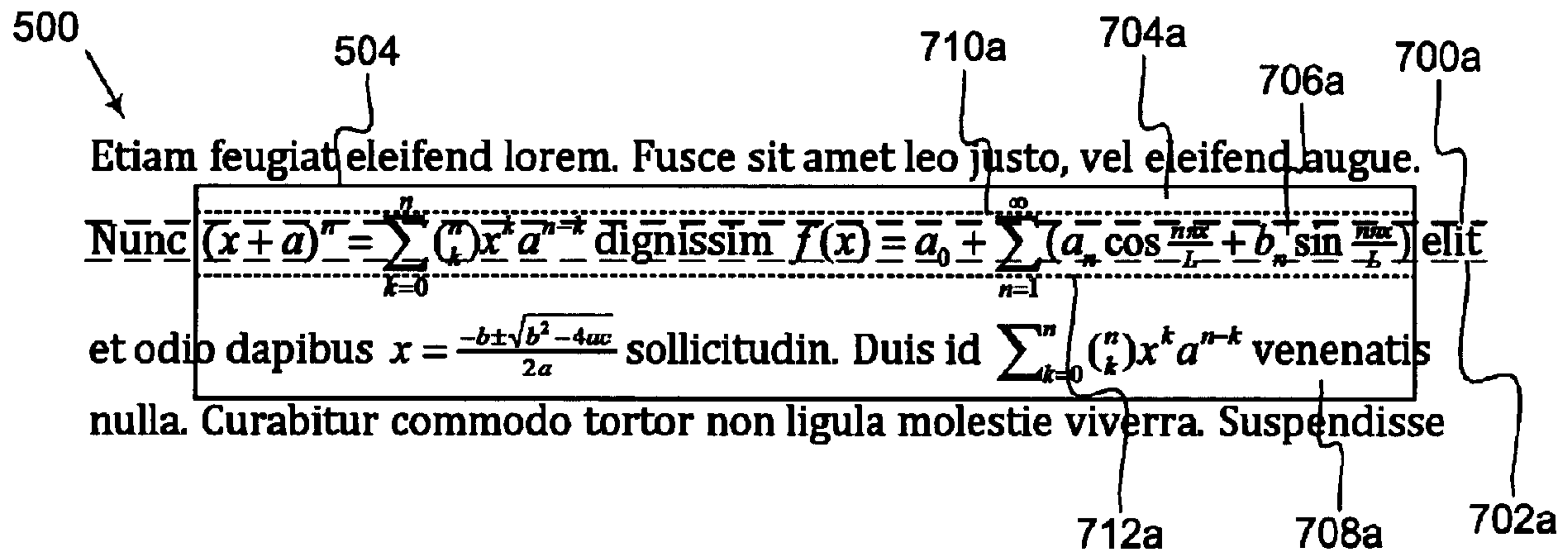

(86) **Date de dépôt PCT/PCT Filing Date:** 2012/01/23
 (87) **Date publication PCT/PCT Publication Date:** 2013/08/01
 (45) **Date de délivrance/Issue Date:** 2018/08/28
 (85) **Entrée phase nationale/National Entry:** 2014/07/09
 (86) **N° demande PCT/PCT Application No.:** EP 2012/000285
 (87) **N° publication PCT/PCT Publication No.:** 2013/110285

(51) **Cl.Int./Int.Cl. G06K 9/00** (2006.01),
G06K 9/34 (2006.01)
 (72) **Inventeurs/Inventors:**
LAZAREVIC, MILOS, RS;
RASKOVIC, MILOS, RS;
OBULJEN, ALJOSA, RS;
PETROVIC TANKOVIC, VANJA, RS
 (73) **Propriétaire/Owner:**
MICROSOFT TECHNOLOGY LICENSING, LLC, US
 (74) **Agent:** SMART & BIGGAR

(54) **Titre : MOTEUR DE DETECTION DE FORMULE**
 (54) **Title: FORMULA DETECTION ENGINE**



(57) **Abrégé/Abstract:**

A formula detection engine and associated method. The formula detection engine locates formulas within a fixed format document portion by identifying formula seeds. The formula detection engine creates and expands a boundary around the formula seed to define a formula area. To eliminate overlap with surrounding normal text, the formula area is divided into multiple formula areas based on vertical position and horizontal spacing between the formula elements. After being vertically ordered, horizontally overlapping formula areas are merged to reconstruct the formula as a flowable element.

(12) INTERNATIONAL APPLICATION PUBLISHED UNDER THE PATENT COOPERATION TREATY (PCT)

(19) World Intellectual Property
Organization
International Bureau(10) International Publication Number
WO 2013/110285 A1(43) International Publication Date
1 August 2013 (01.08.2013)

(51) International Patent Classification:

G06K 9/00 (2006.01) **G06K 9/34** (2006.01)

(21) International Application Number:

PCT/EP2012/000285

(22) International Filing Date:

23 January 2012 (23.01.2012)

(25) Filing Language:

English

(26) Publication Language:

English

(71) Applicant (for all designated States except US): **MI-CROSOFT CORPORATION** [US/US]; One Microsoft Way, Redmond, WA 98052-6399 (US).

(72) Inventors; and

(75) Inventors/Applicants (for US only): **LAZAREVIC, Milos** [RS/RS]; c/o Microsoft Software, Makedonska 30, 6th floor, 11000 Belgrade (RS). **RASKOVIC, Milos** [RS/RS]; c/o Microsoft Software, Makedonska 30, 6th floor, 11000 Belgrade (RS). **OBULJEN, Aljosa** [RS/RS]; c/o Microsoft Software, Makedonska 30, 6th floor, 11000 Belgrade (RS). **PETROVIC TANKOVIC, Vanja** [RS/RS]; c/o Microsoft Software, Makedonska 30, 6th floor, 11000 Belgrade (RS).(74) Agent: **KNAUER, Reinhard**; Grünecker, Kinkeldey, Stockmair & Schwanhäusser, Leopoldstrasse 4, 80802 München (DE).

(81) Designated States (unless otherwise indicated, for every kind of national protection available): AE, AG, AL, AM, AO, AT, AU, AZ, BA, BB, BG, BH, BR, BW, BY, BZ, CA, CH, CL, CN, CO, CR, CU, CZ, DE, DK, DM, DO, DZ, EC, EE, EG, ES, FI, GB, GD, GE, GH, GM, GT, HN, HR, HU, ID, IL, IN, IS, JP, KE, KG, KM, KN, KP, KR, KZ, LA, LC, LK, LR, LS, LT, LU, LY, MA, MD, ME, MG, MK, MN, MW, MX, MY, MZ, NA, NG, NI, NO, NZ, OM, PE, PG, PH, PL, PT, QA, RO, RS, RU, RW, SC, SD, SE, SG, SK, SL, SM, ST, SV, SY, TH, TJ, TM, TN, TR, TT, TZ, UA, UG, US, UZ, VC, VN, ZA, ZM, ZW.

(84) Designated States (unless otherwise indicated, for every kind of regional protection available): ARIPO (BW, GH, GM, KE, LR, LS, MW, MZ, NA, RW, SD, SL, SZ, TZ, UG, ZM, ZW), Eurasian (AM, AZ, BY, KG, KZ, MD, RU, TJ, TM), European (AL, AT, BE, BG, CH, CY, CZ, DE, DK, EE, ES, FI, FR, GB, GR, HR, HU, IE, IS, IT, LT, LU, LV, MC, MK, MT, NL, NO, PL, PT, RO, RS, SE, SI, SK, SM, TR), OAPI (BF, BJ, CF, CG, CI, CM, GA, GN, GQ, GW, ML, MR, NE, SN, TD, TG).

Published:

- with international search report (Art. 21(3))
- with amended claims and statement (Art. 19(1))

(54) Title: FORMULA DETECTION ENGINE

FIG. 7A

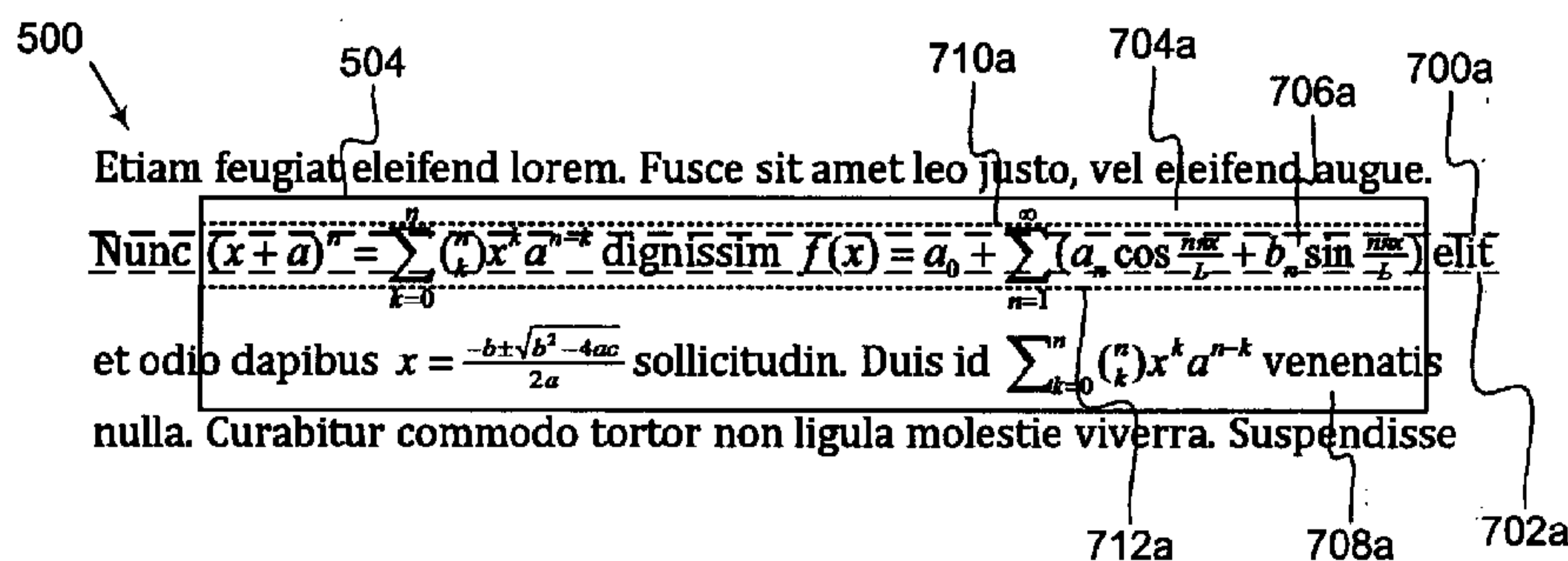

(57) Abstract: A formula detection engine and associated method. The formula detection engine locates formulas within a fixed format document portion by identifying formula seeds. The formula detection engine creates and expands a boundary around the formula seed to define a formula area. To eliminate overlap with surrounding normal text, the formula area is divided into multiple formula areas based on vertical position and horizontal spacing between the formula elements. After being vertically ordered, horizontally overlapping formula areas are merged to reconstruct the formula as a flowable element.

TITLE

Formula Detection Engine

BACKGROUND

[0001] Flow format documents and fixed format documents are widely used and have different purposes. Flow format documents organize a document using complex logical formatting structures such as sections, paragraphs, columns, and tables. As a result, flow format documents offer flexibility and easy modification making them suitable for tasks involving documents that are frequently updated or subject to significant editing. In contrast, fixed format documents organize a document using basic physical layout elements such as text runs, paths, and images to preserve the appearance of the original. Fixed format documents offer consistent and precise format layout making them suitable for tasks involving documents that are not frequently or extensively changed or where uniformity is desired. Examples of such tasks include document archival, high-quality reproduction, and source files for commercial publishing and printing. Fixed format documents are often created from flow format source documents. Fixed format documents also include digital reproductions (e.g., scans and photos) of physical (i.e., paper) documents.

[0002] In situations where editing of a fixed format document is desired but the flow format source document is not available, the fixed format document must be converted into a flow format document. Conversion involves parsing the fixed format document and transforming the basic physical layout elements from the fixed format document into the more complex logical elements used in a flow format document. Existing document converters faced with complex elements, such as mathematical formulas and expressions, resort to base techniques designed to preserve visual fidelity of the layout of the fixed format document (e.g., text frames, line spacing, character spacing, and images) at the expense of the flowability of the output document. The result is a limited flow format document that requires the user to

perform substantial manual reconstruction to have a truly useful flow format document. It is with respect to these and other considerations that the present invention has been made.

BRIEF SUMMARY

[0003] The following Brief Summary is provided to introduce a selection of concepts in a simplified form that are further described below in the Detailed Description. This Brief Summary is not intended to identify key features or essential features of the claimed subject matter, nor is it intended to be used to limit the scope of the claimed subject matter.

[0004] One embodiment of the formula detection engine executes the associated formula detection method as part of the conversion process transforming a fixed format document into a flow format document. The formula detection engine creates the initial formula areas by identifying elements that are potentially part of a mathematical formula and grouping those elements into formula areas based on the relative position of those elements. The formula detection engine begins by identifying formula seeds in the parsed elements. A formula seed is a text element that carries some indication of being part of a formula, such as text runs written in fonts used exclusively, or almost exclusively, to display mathematical expressions and mathematical operators, symbols, or keywords, which are exclusively, or almost exclusively, used in mathematical formulas. Once the formula seeds are identified, the formula detection engine defines a formula area (i.e., a boundary) around each of the detected formula seeds and expands the boundaries to group the formula seeds and other elements based on proximity. All of the page elements enclosed by the bounding box of the formula area are deemed to be the captured elements.

[0005] Next, the formula detection engine eliminates overlap between the formula areas and any surrounding normal text (i.e., textual elements that are not part of a mathematical formula) by subdividing formula areas overlapping normal text based on vertical position and splitting the formula areas based on horizontal spacing. The formula detection engine begins by analyzing each formula area to determine whether or not the formula area

overlaps any areas of normal text. If the formula area overlaps any normal text, the formula detection engine divides the formula area by grouping the captured elements based on vertical position. A new formula area is created around each group of captured elements. The formula detection engine analyzes the contents of new formula areas for overlap with normal text, and, any new formula area still containing normal text are further divided. Once the formula areas are divided, the formula detection engine splits each formula area according to the horizontal spacing between the captured elements.

[0006] Finally, the formula detection engine reconstructs the mathematical formulas as flowable elements by merging any neighboring formula areas based on proximity. The formula detection engine uses the information about the positions of the neighboring text elements to prevent merging of formula areas appearing in different lines on a page. Formula areas that overlap horizontally (i.e., are at least partially vertically aligned) and are within a selected vertical separation distance are grouped as merge candidates. The formula detection engine orders (e.g., sorts) the merge candidates according to the vertical separation between the formula areas and replaces the two formula areas of the merge candidate with a new formula area, provided that the two formula areas have not already been merged and are not in separate lines.

[0006a] According to one aspect of the present invention, there is provided a method for converting a fixed format document containing a formula into a flow format document, the method comprising the acts of: detecting a formula seed of a formula in data parsed from a page of a fixed format document, wherein the formula seed comprises a text element that carries an indication of being part of a formula; creating a formula area bounding the detected formula seed; expanding the formula area to include one or more mathematical elements that are detected on the page based on a proximity to the detected formula seed, wherein together the detected formula seed and the included one or more mathematical elements comprise a plurality of captured elements; placing the plurality of captured elements into one or more groups based

on a vertical position of the plurality of captured elements relative to a line of normal text that overlaps the formula area; creating a new formula area around each of the one or more groups; splitting each new formula area based on a horizontal spacing between the captured elements in the new formula area; selecting a set of split formula areas based on an overlap of the split formula areas; and merging the split formula areas within the set into a single formula for display on a single line of a page of a flow format document.

[0006b] According to another aspect of the present invention, there is provided a system for converting a fixed format document containing a mathematical formula into a flow format document, the system comprising: a document processor; and a memory including computer executable instructions which, when executed by a computer, is operable to: detect the mathematical formula in the fixed format document; convert fixed format elements making up the mathematical formula into flow format elements arranged to substantially preserve the meaning of the mathematical formula, comprising steps to: detect a formula seed of a formula in data parsed from a page of a fixed format document, the formula seed comprising a text element that carries an indication of being part of a formula; create a formula area bounding the detected formula seed; expand the formula area to include one or more mathematical elements that are detected on the page based on a proximity to the detected formula seed, wherein together the detected formula seed and the included one or more mathematical elements comprise a plurality of captured elements; place the plurality of captured elements into one or more groups based on a vertical position of the plurality of captured elements relative to a horizontal position of a line of normal text on the page that overlaps the formula area; create a new formula area around each of the one or more groups; split each new formula area based on a horizontal spacing between the captured elements in the new formula area; select a set of split formula areas based on an overlap of the split formula areas; and merge the split formula area within the set into a single formula for display on a single line of a page of a flow format document.

[0006c] According to still another aspect of the present invention, there is provided a computer storage media containing computer executable instructions which, when executed by a computer, perform a method of converting a fixed format document containing a mathematical formula into a flow format document, the method comprising the acts of: opening the fixed format document containing the mathematical formula; detecting a formula seed of a formula in data parsed from a page of the fixed format document, wherein the formula seed comprises a text element that carries an indication of being part of the mathematical formula; creating a formula area bounding the detected formula seed; expanding the formula area to include one or more mathematical elements that are detected on the page based on a proximity to the detected formula seed, wherein together the detected formula seed and the included one or more mathematical elements comprise a plurality of captured elements; placing the plurality of captured elements into one or more groups based on a vertical position of the plurality of captured elements relative to a line of normal text that overlaps the formula area; creating a new formula area around each of the one or more groups; splitting each new formula area based on a horizontal spacing between the captured elements in the new formula area; selecting a set of split formula area based on an overlap of the split formula areas; and merging the split formula areas within the set into a single formula for display on a single line of a page of a flow format document.

[0007] The details of one or more embodiments are set forth in the accompanying drawings and description below. Other features and advantages will be apparent from a reading of the following detailed description and a review of the associated drawings. It is to be understood that the following detailed description is explanatory only and is not restrictive of the invention as claimed.

BRIEF DESCRIPTION OF THE DRAWINGS

[0008] Further features, aspects, and advantages will become better understood by reference to the following detailed description, appended claims, and accompanying figures,

wherein elements are not to scale so as to more clearly show the details, wherein like reference numbers indicate like elements throughout the several views, and wherein:

Figure 1 illustrates a system including the formula detection engine;

Figure 2 is a block diagram showing the operational flow of one embodiment of the document processor;

Figure 3 is a flow chart showing one embodiment of the formula detection method;

Figure 4 is a flow chart showing one embodiment of the process for creating the initial formula areas used in the formula detection method;

Figure 5A graphically illustrates an exemplary operation of identifying formula seeds applied to a selected portion of the data parsed from a fixed format document that contains several mathematical formulas and equations appearing within a run of normal text;

Figure 5B graphically illustrates an exemplary operation from one embodiment of the process of creating the initial formula areas;

Figure 6 is a flow chart showing one embodiment of the process for eliminating overlap between the formula areas and normal text used in the formula detection method;

Figures 7A-D graphically illustrate selected exemplary operations from one embodiment of the process of eliminating overlap between formula areas and normal text used in one embodiment of the formula detection method;

Figure 8 is a flow diagram showing one embodiment of the process of reconstructing the individual formulas used in the formula detection method;

Figures 9A-B graphically illustrate selected exemplary operations from one embodiment of the process of reconstructing the individual formulas used in the formula detection method;

Figure 10 illustrates an exemplary tablet computing device executing an embodiment of the formula detection engine;

Figure 11 is a simplified block diagram of an exemplary computing device suitable for practicing embodiments of the formula detection engine;

Figure 12A illustrates one embodiment of a mobile computing device executing one embodiment of the formula detection engine;

Figure 12B is a simplified block diagram of an exemplary mobile computing device suitable for practicing embodiments of the formula detection engine; and

Figure 13 is a simplified block diagram of an exemplary distributed computing system suitable for practicing embodiments of the formula detection engine.

DETAILED DESCRIPTION

[0009] A formula detection engine and associated method for identifying mathematical formulas and expressions in data extracted from a fixed format document is described herein and illustrated in the accompanying figures. The formula detection engine locates formulas within the fixed format document portion by identifying a formula seed. The formula detection engine creates and expands a boundary around the formula seed to define a formula area. To eliminate overlap with surrounding normal text, the formula area is divided into multiple formula areas based on vertical position and horizontal spacing between the captured elements. The resulting formula areas vertically ordered and horizontally overlapping formula areas are merged to reconstruct the formula as a flowable element.

[0010] Figure 1 illustrates one embodiment of a system incorporating the formula detection engine **100**. In the illustrated embodiment, the formula detection engine **100** operates as part of a document converter **102** executed on a computing device **104**. The document converter **102** converts a fixed format document **106** into a flow format document **108** using a parser **110**, a document processor **112**, and a serializer **114**. The parser **110** reads and extracts data from the fixed format document **106**. The data extracted from the fixed format document is written to a data store **116** accessible by the document processor **112** and the serializer **114**. The document processor **112** analyzes and transforms the data into flowable elements using one or more detection and/or reconstruction engines (e.g., the formula detection engine **100** of the present invention). Finally, the serializer **114** writes the flowable elements into a flowable document format (e.g., a word processing format).

[0011] Figure 2 illustrates one embodiment of the operational flow of the document processor **112** in greater detail. The document processor **112** includes an optional optical character recognition (OCR) engine **202**, a layout analysis engine **204**, and a semantic analysis engine **206**. The data contained in the data store **116** includes physical layout objects **208** and logical layout objects **210**. In some embodiments, the physical layout objects **208** and logical layout objects **210** are hierarchically arranged in a tree-like array of groups (i.e., data objects). In various embodiments, a page is the top level group for the physical layout objects **208**, while a section is the top level group for the logical layout objects **210**. The data extracted from the fixed format document **106** is generally stored as physical layout objects **208** organized by the containing page in the fixed format document **106**. The basic physical layout objects include text-runs, images, and paths. Text-runs are the text elements in page content streams specifying the positions where characters are drawn when displaying the fixed format document. Images are the raster images (i.e., pictures) stored in the fixed format document **106**. Paths describe elements such as lines, curves (e.g., cubic Bezier curves), and text outlines used to construct vector graphics. Logical data objects include flowable elements such as sections, paragraphs, columns, and tables.

[0012] Where processing begins depends on the type of fixed format document **106** being parsed. A native fixed format document **106a** created directly from a flow format source document contains the some or all of the basic physical layout elements. Generally, the data extracted from a native fixed format document. The embedded data structures are extracted by the parser and are available for immediate use by the document converter; although, in some instances, minor reformatting or other minor processor is applied to organize or standardize the data. In contrast, all information in an image-based fixed format document **106b** created by digitally imaging a physical document (e.g., scanning or photographing) is stored as a series of page images with no additional data (i.e., no text-runs or paths). In this case, the optional optical character recognition engine **202** analyzes each page image and creates corresponding physical layout objects. Once the physical layout objects **208** are available, the layout analysis engine **204** analyzes the layout of the fixed format document.

After layout analysis is complete, the semantic analysis engine **206** enriches the logical layout objects with semantic information obtained from analysis of the physical layout objects and/or logical layout objects.

[0013] Figure 3 is a flow diagram showing one embodiment of the formula detection method **300** executed by the formula detection engine **100**. The formula detection engine **100** creates **302** the initial formula areas by identifying elements in the physical layout objects that are potentially part of a mathematical formula and grouping those elements into formula areas based on the relative position of those elements. Next, the formula detection engine **100** eliminates **304** overlap between the formula areas and any surrounding normal text (i.e., textual elements that are not part of a mathematical formula) by subdividing formula areas overlapping normal text and splitting the formula areas based on horizontal spacing. Finally, the formula detection engine **100** reconstructs **306** the mathematical formulas as flowable elements by merging any neighboring formula areas based on proximity.

[0014] Figure 4 is a flow diagram showing one embodiment of the process of creating **302** the initial formula areas used in the formula detection method **300**. The formula detection engine **100** begins by identifying **402** formula seeds in the parsed elements. Most generally, a formula seed is a text element that carries some indication of being part of a formula. To identify formula seeds, the formula detection engine **100** searches for one or more of the following, without limitation: text runs written in fonts used exclusively, or almost exclusively, to display mathematical expressions and mathematical operators, symbols, or keywords, which are exclusively, or almost exclusively, used in mathematical formulas.

[0015] For example, a word processor may represent formulas with a mathematics font such as Microsoft Corporation's Cambria® Math, while a document preparation system (e.g., LaTeX) may use multiple mathematics font families, such as the Computer Modern math fonts. The formula detection engine **100** also considers the presence of mathematical operators, symbols, and keywords to identify formula seeds because some document processors do not use any special mathematics fonts for mathematics. Examples of the mathematical operators,

symbols, or keywords used for formula detection include operators such as “ Σ ” and “ \mp ”,

symbols such as “ π ”, and keywords such as “cos” representing the cosine function. Generally, the formula detection engine **100** uses keywords that do not have meaning in normal language (e.g., “tan”). In various embodiments, the fonts used to identify formula seeds include, but are not limited to, some or all of the following fonts: Cambria® Math, Computer Modern math Italic (cmmi), Computer Modern math bold Italic (cmmib), Computer Modern math extension (cmex), Computer Modern math symbols (cmsy), Computer Modern bold math symbols (cmbsy), American Math Society extra math symbols – first series (masm), American Math Society extra math symbols – second series (msbm), the extended set of integrals for Computer Modern (esint), MathTime TeX math italic (mtmi), MathTime TeX math symbols (mtsy), MathTime TeX math extension (mtex), and Roland Waldi’s symbols (wasy). In some embodiments, the formula seeds include, but are not limited to, some or all of the Unicode characters or character sets in the ranges of $\#2200\text{--}\#22FF$ (mathematical operators), $\#27C0\text{--}\#27EF$ (miscellaneous mathematical symbols-A), $\#2980\text{--}\#29FF$ (miscellaneous mathematical symbols-B), and $\#2A00\text{--}\#2AFF$ (supplemental mathematical operators) as formula seeds. In various embodiments, the formula seeds include, but are not limited to, some or all of the following textual keywords: *det*, *sin*, *cos*, *tg*, *tan*, *ctg*, *ctan*, *sinh*, *cosh*, *tanh*, *ctanh*, *log*, *ln*, *gcd*, *arcsin*, *arcos*, *arctan*, *sec*, *csc*, *max*, *min*, *inf*, *sup*, *lim*, *sgn*, *exp*, *mod*, and *var*.

[0016] Once the formula seeds are identified, the formula detection engine **100** defines **404** a formula area (i.e., a boundary) around each of the detected formula seeds. Next, the formula detection engine **100** expands **406** the boundaries around the formula seeds to create the initial formula areas. In one embodiment, the adds all of the page elements in the vicinity of a formula seed that have properties of mathematical elements, until there are no such elements remaining. To decide whether or not a page element should be included in the

formula area, the formula detection engine **100** looks for properties identifying the page element as a potential mathematical formula element. In various embodiments, the formula detection engine **100** considers properties including, but not limited to, the Euclidean distance from the formula area to the page element, the text font of the page element, the presence of mathematical operators, symbols, and/or numeric characters (i.e., digits) in the page element, and the dimensions of the page element (i.e., is it taller or wider than standard textual elements). All of the page elements enclosed by the bounding box of the formula area are deemed to be the captured elements.

[0017] Figure 5A graphically illustrates a selected portion of the data **500** parsed from a fixed format document with examples of the formula seeds **502a-d** identified by the formula detection engine **100**. The formula seeds identified by font **502a** are enclosed with broken line rectangles, and the formula seeds identified by mathematical operators **502b**, symbols **502c**, and keywords **502d** are enclosed with solid line ovals.

[0018] Figure 5B graphically illustrates the initial formula area **504** created by the formula detection engine **100** delineated by a bounding box. In the illustrated embodiment, the result is a formula area bounded by rectangles that contain one or more mathematical formulas. Where the mathematical formulas are sufficiently separated from each other, each formula area will capture a single mathematical formula; however, in cases where multiple mathematical formulas are in close proximity, separate mathematical formulas may be captured in a single formula area. Moreover, when more than one formula is captured in a single formula area, the expanded formula area may overlap the surrounding normal text. In the illustrated embodiment, the expanded formula area has captured multiple mathematical formulas **506** and overlaps normal text **508** surrounding the mathematical formulas.

[0019] Figure 6 is a flow diagram showing one embodiment of the process of eliminating **304** overlap between formula areas and normal text used in the formula detection method **300**. The formula detection engine **100** begins by analyzing **600** each formula area to determine whether or not the formula area overlaps any areas of normal text. If the formula

area overlaps any normal text, the formula detection engine **100** continues by grouping **602** each captured element based on the vertical position of the captured element. A new formula area is created **604** around each new grouping of captured elements. The formula detection engine **100** analyzes the contents of new formula areas for overlap with normal text, and, any new formula area containing normal text are further divided. Iteratively analyzing, splitting, and reducing each new formula area, as necessary, allows formula detection engine **100** to handle cases where a formula area overlaps multiple lines of text. Once the formula areas are vertically grouped, the formula detection engine **100** continues by splitting **606** each formula area according to horizontal spacing between the captured elements.

[0020] Figures 7A-D graphically illustrate the subprocess of eliminating **304** overlap between formula areas and normal text used in the formula detection method **300** applied to the initial formula area **504**. Figure 7A shows the initial formula area **504** divided by two horizontal dividers **700a**, **702a** used to group the captured elements of the initial formula area **504** based on vertical position. The horizontal lines **700a**, **702a** correspond to the height of a line of normal text. The first horizontal line **700a** corresponds to the top edge (i.e., border) of the box bounding the line of normal text containing the mathematical formula. The second horizontal line **702a** corresponds to the bottom edge of the box bounding the line of normal text containing the mathematical formulas.

[0021] The dividers **700a**, **702a** divide the initial formula area **504** an upper region **704a**, a middle region **706a**, and a lower region **708a**, which correspond to the areas above, in-line with, and below the line of normal text. If one of the primary dividers **700a**, **702a** intersects captured elements, the formula detection engine **100** establishes a secondary upper horizontal dividing line **710a** and a secondary lower horizontal dividing line **712a**, as necessary, above and below the highest and lowest positions of the intersected captured elements. It should be appreciated by those skilled in the art that the secondary dividers **710a**, **712a** need not be established if the primary dividers **700a**, **702a** do not intersect any captured elements. Alternatively, the secondary dividers **710a**, **712a** may be collinear with the primary dividers **700a**, **702a**.

[0022] Only those captured elements that lie completely above the topmost dividing line **700a, 710a** established by the formula detection engine **100** are placed in a first group corresponding to the upper region **704a**. In the illustrated embodiment, only the symbols “*n*” and “ ∞ ” fall into the first group. Similarly, only those captured elements that lie completely

below the bottommost dividing line **702a, 712a** established by the formula detection engine **100** are placed in a second group corresponding to the lower region **708a**. In the illustrated embodiment, the terms “*k=0*” and “*n=1*” and the text, equations, and formulas in the line below those terms become part of the second group. All of the captured elements that do not fall into either of the first group or the second group are placed into a third group corresponding to the middle region **706a**. In other words, the third group contains the captured elements that lie completely between the primary dividers **700a, 702a**, are intersected by one or both of the primary dividers **700a, 702a**, or vertically overlap an intersected captured element. Any empty groups are discarded.

[0023] Figure 7B illustrates the operation of creating **604** new formula areas around the groups based on the vertical position of the captured elements. Up to three new formula areas are created from the initial formula area **504**. The formula detection engine **100** optionally reduces the dimensions of each new formula area to a suitable extent sufficient to enclose all formula elements captured therein. In the illustrated embodiment, the initial formula area **504** has been subdivided into three new formula areas **714, 716, and 718** and the initial formula area **500** has been discarded. Each of the new formula areas **714, 716, and 718** is subjected to the overlap identification operation **600**. In the illustrated embodiment, the two uppermost new formula areas **714, 716** do not require any further vertical division. The third new formula area **718** still contains vertical overlap between formula areas and normal text. Accordingly, the formula detection engine **100** repeats the grouping by vertical position operation **602** and the

new formula area creation operation **604** on the third new formula area **718**. The lower dividing line **702b** intersects the summation operator, and the upper dividing line **700b** intersects both the square root operator and the summation operator. Note that the secondary upper divider **710b** is established above the tallest intersected captured element (i.e., the square root operator). As before, the dividers **700b**, **702b** split the formula area **718** into the upper region **704b**, the middle region **706b**, and the lower region **708b**. The formula detection engine **100** regroups the captured elements in the formula region **718** in the manner described above.

[0024] Figure 7C illustrates the final result of the iterative application of the overlap identification operation **600**, the grouping by vertical position operation **602**, and the new formula area creation operation **604**. The third new formula region **718** has been divided into two new formula areas **724**, **726**. The first formula area **724** corresponds to the upper region **704b** of the formula region **718**, and the second formula area **726** corresponds to the middle region **706b** of the formula region **718**. The empty group corresponding to the middle region **706b** of the formula region **718** has been discarded. Neither of the remaining formula areas **724**, **726** require any further vertical grouping.

[0025] Figure 7D illustrates the operation of splitting **606** the formula areas based on the horizontal spacing between captured elements. The formula detection engine **100** begins by horizontally scanning each formula area and determining the horizontal distance between each pair of consecutive captured elements in a formula area. In some embodiments, the horizontal scan direction corresponds to the reading direction of the document language. In other embodiments, the horizontal scan direction is left to right or right to left regardless of the document language. The formula detection engine **100** divides the formula area between two consecutive captured elements separated by a horizontal distance greater than a selected threshold distance to create new formula areas. In various embodiments, the horizontal distance between consecutive captured elements is determined from the whitespace. The dotted break lines **730** shown in Figure 7D indicate where the horizontal separation exceeds the

selected threshold. In some embodiments, a single threshold is used. In other embodiments, the threshold varies based on the surrounding text.

[0026] Figure 8 is a flow diagram showing one embodiment of the subprocess of reconstructing **306** the individual formulas by grouping the formula boxes. The formula detection engine **100** begins by locating **800** the normal text elements appearing to the left and the right of each formula area. The formula detection engine **100** uses the information about the positions of the neighboring text elements to prevent merging of formula areas appearing in different lines on a page. The formula detection engine **100** then generates sets of merge candidates from the available formula areas. Formula areas that overlap horizontally (i.e., are at least partially vertically aligned) and are within a selected vertical separation distance are grouped **802** as merge candidates. The formula detection engine orders (e.g., sorts) **804** the merge candidates according to the vertical distance between the formula areas. In some embodiments, the merge candidates are sorted in ascending order. In other embodiments, the merge candidates are sorted in descending order. Working through the sorted merge candidates from first to last, the formula detection engine **100** replaces **806** two formula areas making up the merge candidate with a new formula area, provided that the two formula areas have not already been merged into a single formula area and their vertical positions are not associated with the vertical positions of separate lines. In some embodiments, whether or not the formula areas are in the same line on the page is determined from the normal text to the right and/or left of each formula area. If the normal text to the right or left of each formula area is the same, the formula areas are determined to be located within the same line on the page. Conversely, a difference in the normal text to the right or left of the formula areas indicates that the formula areas are located in different lines on the page. The boundary of the merged formula area is defined by the maximum extents of the two formula areas making up the merge candidate. In other words, the new formula area is defined by selecting the topmost, bottommost, leftmost, and rightmost boundary from the top, bottom, left, and right boundaries of the merge candidates.

[0027] Figures 9A and 9B graphically illustrate selected operations from the subprocess of reconstructing **306** the individual formulas applied to the text run **500**. Figure 9A shows selected formula areas grouped into merge candidates. The first merge candidate group **900a** includes formula areas **914a**, **916a**, and **924a**. The second merge candidate group **900b** includes formula areas **914b**, **916b**, and **924b**. Formula areas **924a** and **924b** are not merge candidates with formula areas **926a** and **926b**, respectively, because the vertical separation distance exceeds the selected threshold. Additionally, formula areas **926a** and **926b** are not merged with merge groups **900a** and **900b**, respectively, because the normal text to the left and right differ between them (i.e., the formula areas are in different lines on the page). Figure 9B shows the final solution with each of the four formulas **902a-d** properly separated from each other and from the surrounding normal text.

[0028] As used herein, the terms “area,” “boundary,” “box,” are used interchangeably. Similarly, the terms “line” and “divider” are used interchangeably. It should be appreciated by those skilled in the art that the boundaries and dividers described herein need not be actually visually represented and/or displayed during the formula detection method. Additionally, the boundaries and dividers are not limited to boxes or lines. The boundaries and dividers may take other shapes (e.g., curves) without departing from the scope of the present invention. Moreover, the boundaries and dividers simply using coordinates or other reference systems. Terms connoting shapes (e.g., rectangle, box, line, and oval) should not be construed as limiting and should be read broadly as encompassing any suitable boundary or divider, as appropriate, unless the specification expressly indicates otherwise.

[0029] The formula detection engine and associated formula detection method described herein is useful to identify each distinct mathematical formula appearing in a fixed format document and to convert each identified mathematical formula into a flow format element. In various embodiments, the output of the formula detection engine is further processed by additional formatting engines within the document processor prior to being serialized.

[0030] While the invention has been described in the general context of program modules that execute in conjunction with an application program that runs on an operating system on a computer, those skilled in the art will recognize that the invention may also be implemented in combination with other program modules. Generally, program modules include routines, programs, components, data structures, and other types of structures that perform particular tasks or implement particular abstract data types.

[0031] The embodiments and functionalities described herein may operate via a multitude of computing systems including, without limitation, desktop computer systems, wired and wireless computing systems, mobile computing systems (e.g., mobile telephones, netbooks, tablet or slate type computers, notebook computers, and laptop computers), handheld devices, multiprocessor systems, microprocessor-based or programmable consumer electronics, minicomputers, and mainframe computers. Figure 10 illustrates an exemplary tablet computing device **1000** executing an embodiment of the formula detection engine **100**. In addition, the embodiments and functionalities described herein may operate over distributed systems (e.g., cloud-based computing systems), where application functionality, memory, data storage and retrieval and various processing functions may be operated remotely from each other over a distributed computing network, such as the Internet or an intranet. User interfaces and information of various types may be displayed via on-board computing device displays or via remote display units associated with one or more computing devices. For example user interfaces and information of various types may be displayed and interacted with on a wall surface onto which user interfaces and information of various types are projected. Interaction with the multitude of computing systems with which embodiments of the invention may be practiced include, keystroke entry, touch screen entry, voice or other audio entry, gesture entry where an associated computing device is equipped with detection (e.g., camera) functionality for capturing and interpreting user gestures for controlling the functionality of the computing device, and the like. Figures 11 through 13 and the associated descriptions provide a discussion of a variety of operating environments in which embodiments of the invention may be practiced. However, the devices and systems illustrated and discussed with respect to

Figures 11 through 13 are for purposes of example and illustration and are not limiting of a vast number of computing device configurations that may be utilized for practicing embodiments of the invention, described herein.

[0032] Figure 11 is a block diagram illustrating physical components (i.e., hardware) of a computing device **1100** with which embodiments of the invention may be practiced. The computing device components described below may be suitable for the computing devices described above. In a basic configuration, the computing device **1100** may include at least one processing unit **1102** and a system memory **1104**. Depending on the configuration and type of computing device, the system memory **1104** may comprise, but is not limited to, volatile storage (e.g., random access memory), non-volatile storage (e.g., read-only memory), flash memory, or any combination of such memories. The system memory **1104** may include an operating system **1105** and one or more program modules **1106** suitable for running software applications **1120** such as the formula detection engine **100**, the parser **110**, the document converter **112**, and the serializer **114**. The operating system **1105**, for example, may be suitable for controlling the operation of the computing device **1100**. Furthermore, embodiments of the invention may be practiced in conjunction with a graphics library, other operating systems, or any other application program and is not limited to any particular application or system. This basic configuration is illustrated in Figure 11 by those components within a dashed line **1108**. The computing device **1100** may have additional features or functionality. For example, the computing device **1100** may also include additional data storage devices (removable and/or non-removable) such as, for example, magnetic disks, optical disks, or tape. Such additional storage is illustrated in Figure 11 by a removable storage device **1109** and a non-removable storage device **1110**.

[0033] As stated above, a number of program modules and data files may be stored in the system memory **1104**. While executing on the processing unit **1102**, the program modules **1106**, such as the formula detection engine **100**, the parser **110**, the document processor **112**, and the serializer **114** may perform processes including, for example, one or more of the stages of the formula detection method **300**. The aforementioned process is an

example, and the processing unit **1102** may perform other processes. Other program modules that may be used in accordance with embodiments of the present invention may include electronic mail and contacts applications, word processing applications, spreadsheet applications, database applications, slide presentation applications, drawing or computer-aided application programs, etc.

[0034] Furthermore, embodiments of the invention may be practiced in an electrical circuit comprising discrete electronic elements, packaged or integrated electronic chips containing logic gates, a circuit utilizing a microprocessor, or on a single chip containing electronic elements or microprocessors. For example, embodiments of the invention may be practiced via a system-on-a-chip (SOC) where each or many of the components illustrated in Figure 11 may be integrated onto a single integrated circuit. Such an SOC device may include one or more processing units, graphics units, communications units, system virtualization units and various application functionality all of which are integrated (or “burned”) onto the chip substrate as a single integrated circuit. When operating via an SOC, the functionality, described herein, with respect to the formula detection engine **100**, the parser **110**, the document processor **112**, and the serializer **114** may be operated via application-specific logic integrated with other components of the computing device **1100** on the single integrated circuit (chip). Embodiments of the invention may also be practiced using other technologies capable of performing logical operations such as, for example, AND, OR, and NOT, including but not limited to mechanical, optical, fluidic, and quantum technologies. In addition, embodiments of the invention may be practiced within a general purpose computer or in any other circuits or systems.

[0035] The computing device **1100** may also have one or more input device(s) **1112** such as a keyboard, a mouse, a pen, a sound input device, a touch input device, etc. The output device(s) **1114** such as a display, speakers, a printer, etc. may also be included. The aforementioned devices are examples and others may be used. The computing device **1100** may include one or more communication connections **1116** allowing communications with other computing devices **1118**. Examples of suitable communication connections **1116** include,

but are not limited to, RF transmitter, receiver, and/or transceiver circuitry; universal serial bus (USB), parallel, or serial ports, and other connections appropriate for use with the applicable computer readable media.

[0036] Embodiments of the invention, for example, may be implemented as a computer process (method), a computing system, or as an article of manufacture, such as a computer program product or computer readable media. The computer program product may be a computer storage media readable by a computer system and encoding a computer program of instructions for executing a computer process.

[0037] The term computer readable media as used herein may include computer storage media and communication media. Computer storage media may include volatile and nonvolatile, removable and non-removable media implemented in any method or technology for storage of information, such as computer readable instructions, data structures, program modules, or other data. The system memory **1104**, the removable storage device **1109**, and the non-removable storage device **1110** are all computer storage media examples (i.e., memory storage.) Computer storage media may include, but is not limited to, RAM, ROM, electrically erasable read-only memory (EEPROM), flash memory or other memory technology, CD-ROM, digital versatile disks (DVD) or other optical storage, magnetic cassettes, magnetic tape, magnetic disk storage or other magnetic storage devices, or any other medium which can be used to store information and which can be accessed by the computing device **1100**. Any such computer storage media may be part of the computing device **1100**.

[0038] Communication media may be embodied by computer readable instructions, data structures, program modules, or other data in a modulated data signal, such as a carrier wave or other transport mechanism, and includes any information delivery media. The term "modulated data signal" may describe a signal that has one or more characteristics set or changed in such a manner as to encode information in the signal. By way of example, and not limitation, communication media may include wired media such as a wired network or direct-

wired connection, and wireless media such as acoustic, radio frequency (RF), infrared, and other wireless media.

[0039] Figures 12A and 12B illustrate a mobile computing device **1200**, for example, a mobile telephone, a smart phone, a tablet personal computer, a laptop computer, and the like, with which embodiments of the invention may be practiced. With reference to Figure 12A, an exemplary mobile computing device **1200** for implementing the embodiments is illustrated. In a basic configuration, the mobile computing device **1200** is a handheld computer having both input elements and output elements. The mobile computing device **1200** typically includes a display **1205** and one or more input buttons **1210** that allow the user to enter information into the mobile computing device **1200**. The display **1205** of the mobile computing device **1200** may also function as an input device (e.g., a touch screen display). If included, an optional side input element **1215** allows further user input. The side input element **1215** may be a rotary switch, a button, or any other type of manual input element. In alternative embodiments, mobile computing device **1200** may incorporate more or less input elements. For example, the display **1205** may not be a touch screen in some embodiments. In yet another alternative embodiment, the mobile computing device **1200** is a portable phone system, such as a cellular phone. The mobile computing device **1200** may also include an optional keypad **1235**. Optional keypad **1235** may be a physical keypad or a "soft" keypad generated on the touch screen display. In various embodiments, the output elements include the display **1205** for showing a graphical user interface (GUI), a visual indicator **1220** (e.g., a light emitting diode), and/or an audio transducer **1225** (e.g., a speaker). In some embodiments, the mobile computing device **1200** incorporates a vibration transducer for providing the user with tactile feedback. In yet another embodiment, the mobile computing device **1200** incorporates input and/or output ports, such as an audio input (e.g., a microphone jack), an audio output (e.g., a headphone jack), and a video output (e.g., a HDMI port) for sending signals to or receiving signals from an external device.

[0040] Figure 12B is a block diagram illustrating the architecture of one embodiment of a mobile computing device. That is, the mobile computing device **1200** can incorporate a

system (i.e., an architecture) **1202** to implement some embodiments. In one embodiment, the system **1202** is implemented as a “smart phone” capable of running one or more applications (e.g., browser, e-mail, calendaring, contact managers, messaging clients, games, and media clients/players). In some embodiments, the system **1202** is integrated as a computing device, such as an integrated personal digital assistant (PDA) and wireless phone.

[0041] One or more application programs **1266** may be loaded into the memory **1262** and run on or in association with the operating system **1264**. Examples of the application programs include phone dialer programs, e-mail programs, personal information management (PIM) programs, word processing programs, spreadsheet programs, Internet browser programs, messaging programs, and so forth. The system **1202** also includes a non-volatile storage area **1268** within the memory **1262**. The non-volatile storage area **1268** may be used to store persistent information that should not be lost if the system **1202** is powered down. The application programs **1266** may use and store information in the non-volatile storage area **1268**, such as e-mail or other messages used by an e-mail application, and the like. A synchronization application (not shown) also resides on the system **1202** and is programmed to interact with a corresponding synchronization application resident on a host computer to keep the information stored in the non-volatile storage area **1268** synchronized with corresponding information stored at the host computer. As should be appreciated, other applications may be loaded into the memory **1262** and run on the mobile computing device **1200**, including the formula detection engine **100**, the parser **110**, the document processor **112**, and the serializer **114** described herein.

[0042] The system **1202** has a power supply **1270**, which may be implemented as one or more batteries. The power supply **1270** might further include an external power source, such as an AC adapter or a powered docking cradle that supplements or recharges the batteries.

[0043] The system **1202** may also include a radio **1272** that performs the function of transmitting and receiving radio frequency communications. The radio **1272** facilitates wireless connectivity between the system **1202** and the “outside world”, via a communications carrier

or service provider. Transmissions to and from the radio **1272** are conducted under control of the operating system **1264**. In other words, communications received by the radio **1272** may be disseminated to the application programs **1266** via the operating system **1264**, and vice versa.

[0044] The radio **1272** allows the system **1202** to communicate with other computing devices, such as over a network. The radio **1272** is one example of communication media. Communication media may typically be embodied by computer readable instructions, data structures, program modules, or other data in a modulated data signal, such as a carrier wave or other transport mechanism, and includes any information delivery media. The term “modulated data signal” means a signal that has one or more of its characteristics set or changed in such a manner as to encode information in the signal. By way of example, and not limitation, communication media includes wired media such as a wired network or direct-wired connection, and wireless media such as acoustic, RF, infrared and other wireless media. The term computer readable media as used herein includes both storage media and communication media.

[0045] This embodiment of the system **1202** provides notifications using the visual indicator **1220** that can be used to provide visual notifications and/or an audio interface **1274** producing audible notifications via the audio transducer **1225**. In the illustrated embodiment, the visual indicator **1220** is a light emitting diode (LED) and the audio transducer **1225** is a speaker. These devices may be directly coupled to the power supply **1270** so that when activated, they remain on for a duration dictated by the notification mechanism even though the processor **1260** and other components might shut down for conserving battery power. The LED may be programmed to remain on indefinitely until the user takes action to indicate the powered-on status of the device. The audio interface **1274** is used to provide audible signals to and receive audible signals from the user. For example, in addition to being coupled to the audio transducer **1225**, the audio interface **1274** may also be coupled to a microphone to receive audible input, such as to facilitate a telephone conversation. In accordance with embodiments of the present invention, the microphone may also serve as an audio sensor to facilitate control of notifications, as will be described below. The system **1202** may further

include a video interface **1276** that enables an operation of an on-board camera **1230** to record still images, video stream, and the like.

[0046] A mobile computing device **1200** implementing the system **1202** may have additional features or functionality. For example, the mobile computing device **1200** may also include additional data storage devices (removable and/or non-removable) such as, magnetic disks, optical disks, or tape. Such additional storage is illustrated in Figure 12B by the non-volatile storage area **1268**. Computer storage media may include volatile and nonvolatile, removable and non-removable media implemented in any method or technology for storage of information, such as computer readable instructions, data structures, program modules, or other data.

[0047] Data/information generated or captured by the mobile computing device **1200** and stored via the system **1202** may be stored locally on the mobile computing device **1200**, as described above, or the data may be stored on any number of storage media that may be accessed by the device via the radio **1272** or via a wired connection between the mobile computing device **1200** and a separate computing device associated with the mobile computing device **1200**, for example, a server computer in a distributed computing network, such as the Internet. As should be appreciated such data/information may be accessed via the mobile computing device **1200** via the radio **1272** or via a distributed computing network. Similarly, such data/information may be readily transferred between computing devices for storage and use according to well-known data/information transfer and storage means, including electronic mail and collaborative data/information sharing systems.

[0048] Figure 13 illustrates one embodiment of the architecture of a system for providing the formula detection engine **100**, the parser **110**, the document processor **112**, and the serializer **114** to one or more client devices, as described above. Content developed, interacted with or edited in association with the formula detection engine **100**, the parser **110**, the document processor **112**, and the serializer **114** may be stored in different communication channels or other storage types. For example, various documents may be stored using a

directory service **1322**, a web portal **1324**, a mailbox service **1326**, an instant messaging store **1328**, or a social networking site **1330**. The formula detection engine **100**, the parser **110**, the document processor **112**, and the serializer **114** may use any of these types of systems or the like for enabling data utilization, as described herein. A server **1320** may provide the formula detection engine **100**, the parser **110**, the document processor **112**, and the serializer **114** to clients. As one example, the server **1320** may be a web server providing the formula detection engine **100**, the parser **110**, the document processor **112**, and the serializer **114** over the web. The server **1320** may provide the formula detection engine **100**, the parser **110**, the document processor **112**, and the serializer **114** over the web to clients through a network **1315**. By way of example, the client computing device **1318** may be implemented as the computing device **1100** and embodied in a personal computer **1318a**, a tablet computing device **1318b** and/or a mobile computing device **1318c** (e.g., a smart phone). Any of these embodiments of the client computing device **1318** may obtain content from the store **1316**.

[0049] Embodiments of the present invention, for example, are described above with reference to block diagrams and/or operational illustrations of methods, systems, and computer program products according to embodiments of the invention. The functions/acts noted in the blocks may occur out of the order as shown in any flowchart. For example, two blocks shown in succession may in fact be executed substantially concurrently or the blocks may sometimes be executed in the reverse order, depending upon the functionality/acts involved.

[0050] While certain embodiments of the invention have been described, other embodiments may exist. Furthermore, although embodiments of the present invention have been described as being associated with data stored in memory and other storage mediums, data can also be stored on or read from other types of computer-readable media, such as secondary storage devices, like hard disks, floppy disks, or a CD-ROM, a carrier wave from the Internet, or other forms of RAM or ROM. Further, the disclosed methods' stages may be modified in any manner, including by reordering stages and/or inserting or deleting stages, without departing from the invention.

[0051] In various embodiments, the types of networks used for communication between the computing devices that make up the present invention include, but are not limited to, an internet, an intranet, wide area networks (WAN), local area networks (LAN), and virtual private networks (VPN). In the present application, the networks include the enterprise network and the network through which the client computing device accesses the enterprise network (i.e., the client network). In one embodiment, the client network is part of the enterprise network. In another embodiment, the client network is a separate network accessing the enterprise network through externally available entry points, such as a gateway, a remote access protocol, or a public or private internet address.

[0052] The description and illustration of one or more embodiments provided in this application are not intended to limit or restrict the scope of the invention as claimed in any way. The embodiments, examples, and details provided in this application are considered sufficient to convey possession and enable others to make and use the best mode of claimed invention. The claimed invention should not be construed as being limited to any embodiment, example, or detail provided in this application. Regardless of whether shown and described in combination or separately, the various features (both structural and methodological) are intended to be selectively included or omitted to produce an embodiment with a particular set of features. Having been provided with the description and illustration of the present application, one skilled in the art may envision variations, modifications, and alternate embodiments falling within the scope of the claimed invention and the general inventive concept embodied in this application.

CLAIMS:

1. A method for converting a fixed format document containing a formula into a flow format document, the method comprising the acts of:

detecting a formula seed of a formula in data parsed from a page of a fixed format document, wherein the formula seed comprises a text element that carries an indication of being part of a formula;

creating a formula area bounding the detected formula seed;

expanding the formula area to include one or more mathematical elements that are detected on the page based on a proximity to the detected formula seed, wherein together the detected formula seed and the included one or more mathematical elements comprise a plurality of captured elements;

placing the plurality of captured elements into one or more groups based on a vertical position of the plurality of captured elements relative to a line of normal text that overlaps the formula area;

creating a new formula area around each of the one or more groups;

splitting each new formula area based on a horizontal spacing between the captured elements in the new formula area;

selecting a set of split formula areas based on an overlap of the split formula areas; and

merging the split formula areas within the set into a single formula for display on a single line of a page of a flow format document.

2. The method of claim 1 wherein the act of detecting a formula seed in a fixed format document further comprises the act of detecting at least one of a mathematical keyword, a mathematical symbol, and a mathematical operator in the fixed format document.

3. The method of claim 2 wherein the act of detecting a formula seed in a fixed format document further comprises the act of detecting text proximate to at least one of the mathematical keyword, the mathematical symbol, and the mathematical operator as being within the formula area.

4. The method of claim 3 wherein the act of detecting text proximate to at least one of the mathematical keyword, the mathematical symbol, and the mathematical operator as being within the formula area further comprises the act of detecting text as being within the formula area based on the relative position of the text to at least one of the mathematical keyword, the mathematical symbol, and the mathematical operator.

5. The method of claim 1 wherein the act of detecting a formula seed in a fixed format document further comprises the act of detecting text in the fixed format document rendered in a mathematical font.

6. A system for converting a fixed format document containing a mathematical formula into a flow format document, the system comprising:

a document processor; and

a memory including computer executable instructions which, when executed by a computer, is operable to:

detect the mathematical formula in the fixed format document;

convert fixed format elements making up the mathematical formula into flow format elements arranged to substantially preserve the meaning of the mathematical formula, comprising steps to:

detect a formula seed of a formula in data parsed from a page of a fixed format document, the formula seed comprising a text element that carries an indication of being part of a formula;

create a formula area bounding the detected formula seed;

expand the formula area to include one or more mathematical elements that are detected on the page based on a proximity to the detected formula seed, wherein together the detected formula seed and the included one or more mathematical elements comprise a plurality of captured elements;

place the plurality of captured elements into one or more groups based on a vertical position of the plurality of captured elements relative to a horizontal position of a line of normal text on the page that overlaps the formula area;

create a new formula area around each of the one or more groups;

split each new formula area based on a horizontal spacing between the captured elements in the new formula area;

select a set of split formula areas based on an overlap of the split formula areas; and

merge the split formula area within the set into a single formula for display on a single line of a page of a flow format document.

7. The system of claim 6 wherein the document processor is further operable to detect at least one of a mathematical keyword, a mathematical symbol, and a mathematical operator in the fixed format document.

8. The system of claim 6 wherein the document processor is further operable to detect the fixed format elements corresponding to the mathematical formula based on the relative position of one of the fixed format elements to at least one of the mathematical keyword, the mathematical symbol, the mathematical operator, and another of the fixed format elements.

9. The system of claim 6 wherein the document processor is further operable to detect a mathematical font in the fixed format document.

10. The system of claim 9 wherein the document processor is further operable to detect fixed format elements rendered in the mathematical font.

11. The system of claim 6 wherein the document processor is further operable to detect the fixed format elements corresponding to the mathematical formula based on the relative positions of the fixed format elements.

12. The system of claim 6 wherein the document processor is further operable to group the fixed format elements based on the vertical position of the fixed format elements relative to a reference position within a formula area containing the mathematical formula.

13. The system of claim 6 wherein the document processor is further operable to:

detect a line of text aligned with the mathematical formula; and

group the fixed format elements based on the offsets of the fixed format elements relative to the position of the line of text.

14. A computer storage media containing computer executable instructions which, when executed by a computer, perform a method of converting a fixed format document containing a mathematical formula into a flow format document, the method comprising the acts of:

opening the fixed format document containing the mathematical formula;

detecting a formula seed of a formula in data parsed from a page of the fixed format document, wherein the formula seed comprises a text element that carries an indication of being part of the mathematical formula;

creating a formula area bounding the detected formula seed;

expanding the formula area to include one or more mathematical elements that are detected on the page based on a proximity to the detected formula seed, wherein together the detected formula seed and the included one or more mathematical elements comprise a plurality of captured elements;

placing the plurality of captured elements into one or more groups based on a vertical position of the plurality of captured elements relative to a line of normal text that overlaps the formula area;

creating a new formula area around each of the one or more groups;

splitting each new formula area based on a horizontal spacing between the captured elements in the new formula area;

selecting a set of split formula area based on an overlap of the split formula areas; and

merging the split formula areas within the set into a single formula for display on a single line of a page of a flow format document.

15. The computer storage media of claim 14 wherein the act of detecting fixed format elements corresponding to the mathematical formula further comprises the acts of:

detecting at least one of a math symbol, a math operator, a math keyword, and a math font in the fixed format document; and

identifying the fixed format elements proximate to at least one of a math symbol, a math operator, and a math keyword in the fixed format document as being within a formula area; and

identifying the fixed format elements rendered in the mathematical font as being within the formula area.

16. The computer storage media of claim 15 wherein the act of detecting the fixed format elements corresponding to the mathematical formula further comprises the act of identifying the fixed format elements in the formula area that are at least partially horizontally aligned with another fixed format element in the formula area as corresponding to the mathematical formula.

17. The method of claim 1, wherein selecting the set of split formula areas is further based on a vertical position of each of the split formula areas.

18. The method of claim 17, wherein selecting the set of split formula areas further comprises placing split formula areas in the set when a vertical separation distance between two successively ordered split formula areas does not exceed a selected distance threshold.

19. The method of claim 1, wherein the horizontal spacing between the captured element in the new formula area is based on a selected distance threshold.

20. The method of claim 19, wherein the selected distance threshold varies based on a type of the one or more mathematical elements.

21. The method of claim 1, wherein selecting a set of split formula areas is based on a horizontal overlap of the split formula areas.

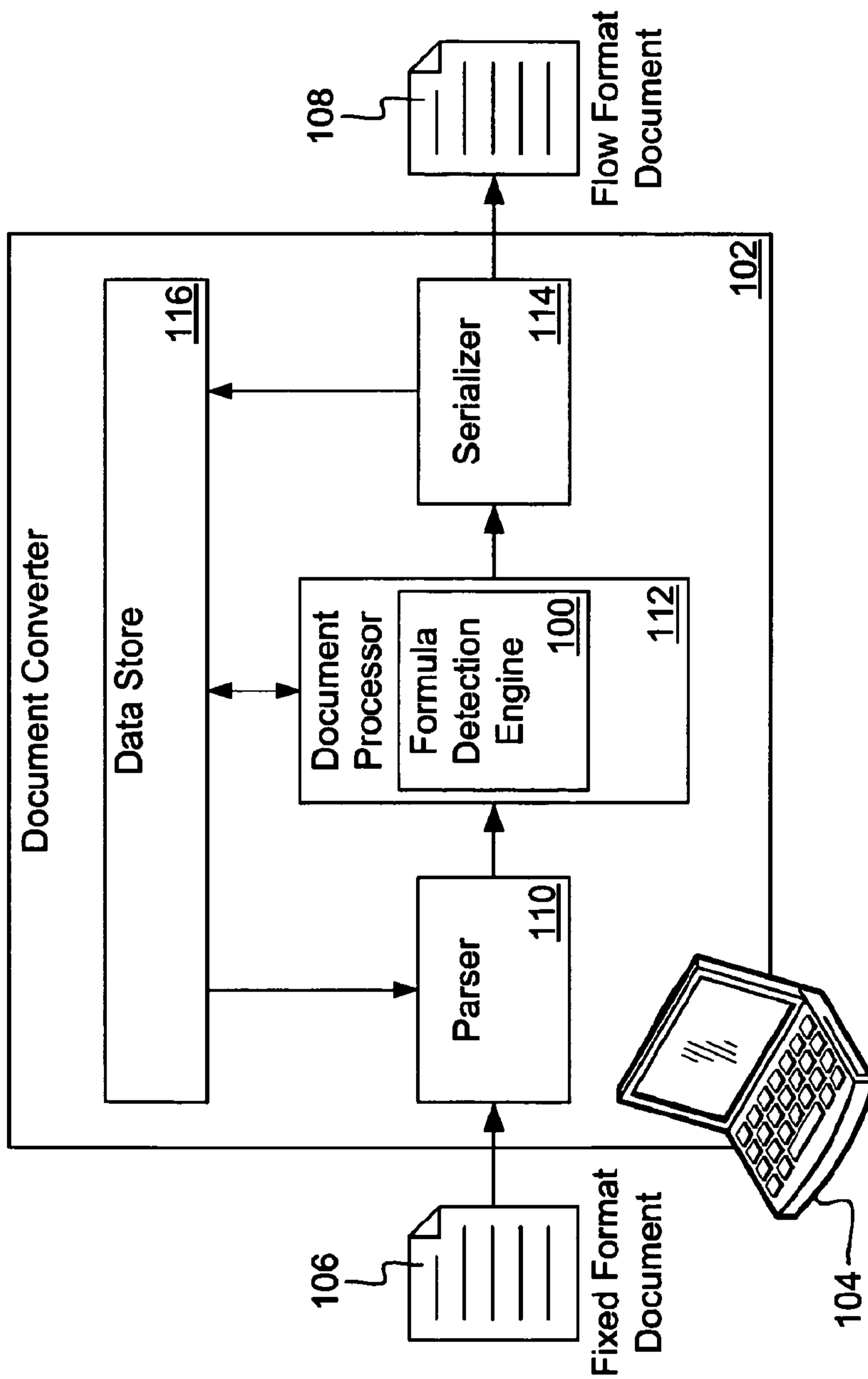

FIG. 1

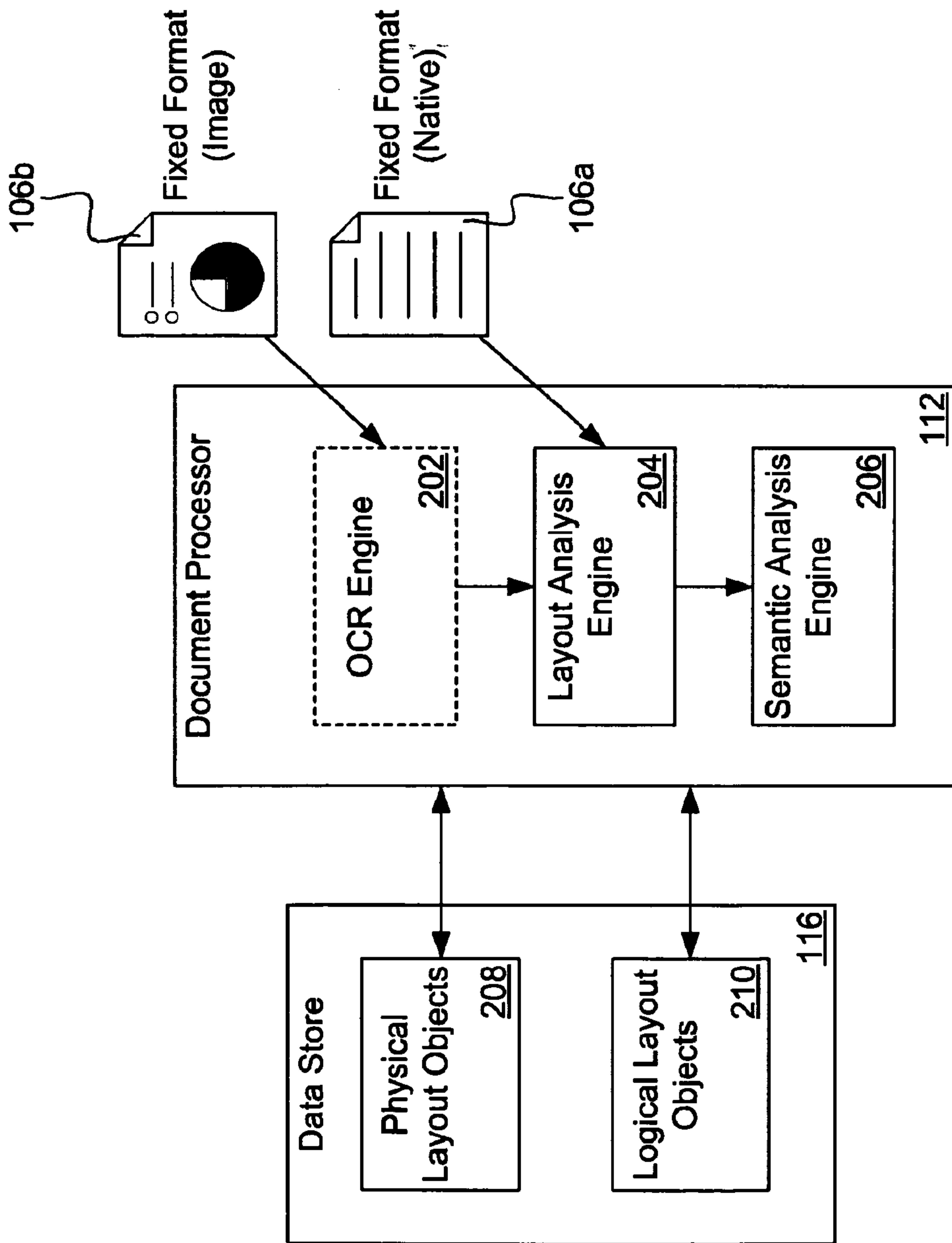

FIG. 2

3/19

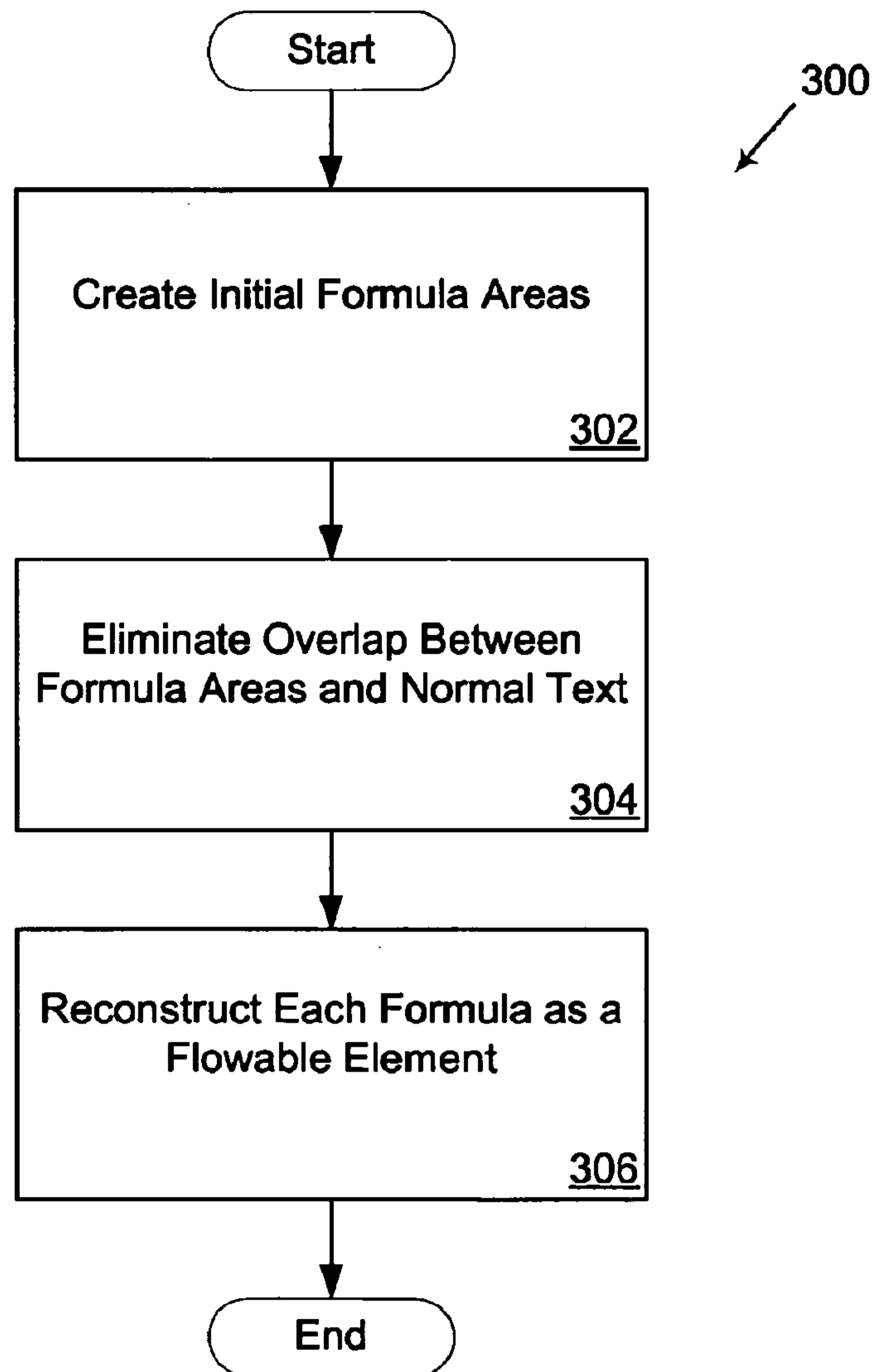

FIG. 3

4/19

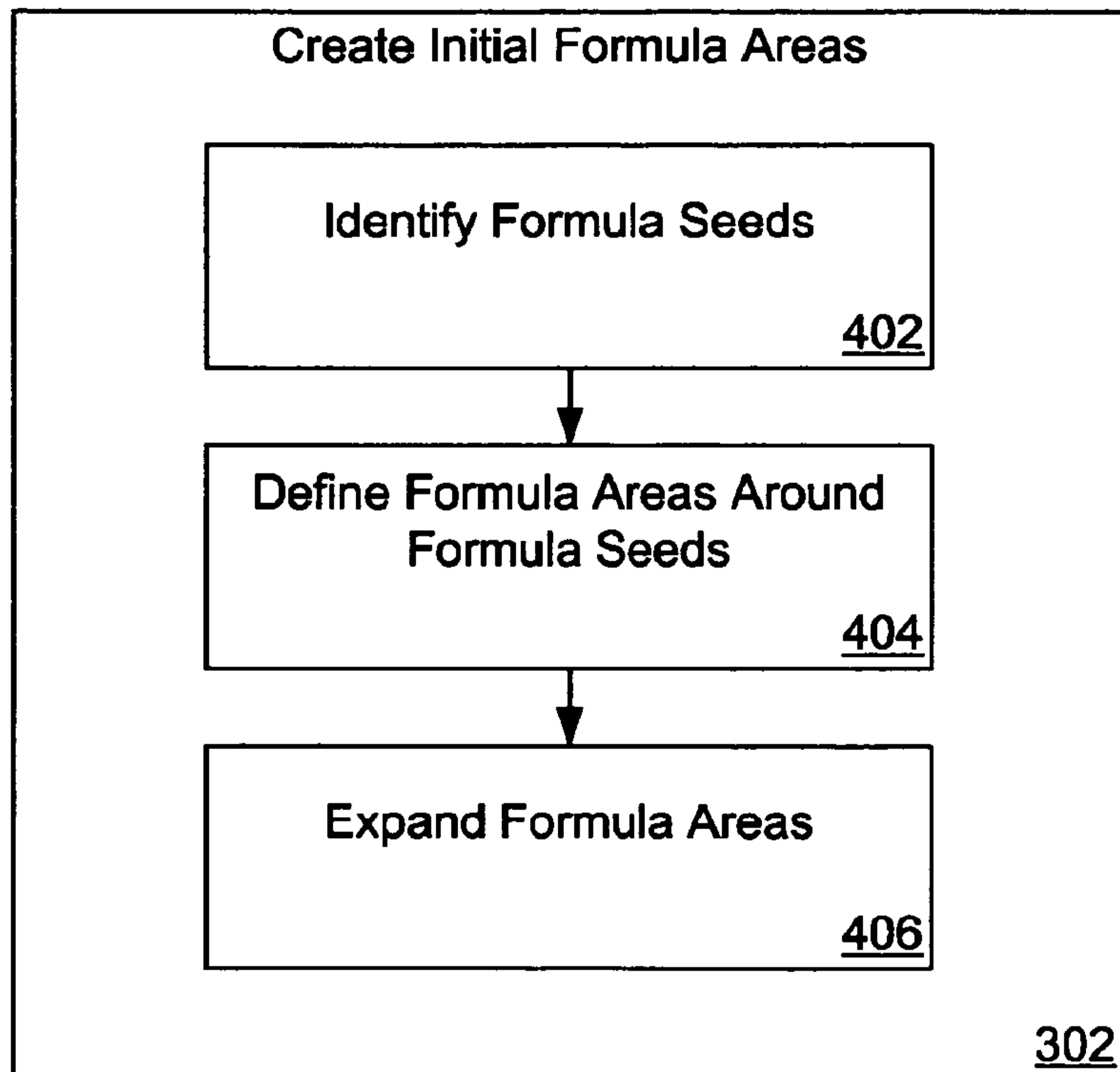

FIG. 4

500 →

502c 502a 502c 502c 502c 502c 502c 502c 502c

Etiam feugiat eleifend lorem. Fusce sit amet leo justo, vel eleifend augue.

Nunc $(x+a)^n = \sum_{k=0}^n \binom{n}{k} x^k a^{n-k}$ dignissim $f(x) = a_0 + \sum_{n=1}^{\infty} (a_n \cos \frac{n\pi x}{L} + b_n \sin \frac{n\pi x}{L})$ elit

et odio dapibus $x = \frac{-b \pm \sqrt{b^2 - 4ac}}{2a}$ sollicitudin. Duis id $\sum_{k=0}^n \binom{n}{k} x^k a^{n-k}$ venenatis

nulla. Curabitur commodo tortor non ligula molestie viverra. Suspendisse

502a 502b 502a 502b 502a 502b 502a 502b 502a

FIG. 5A

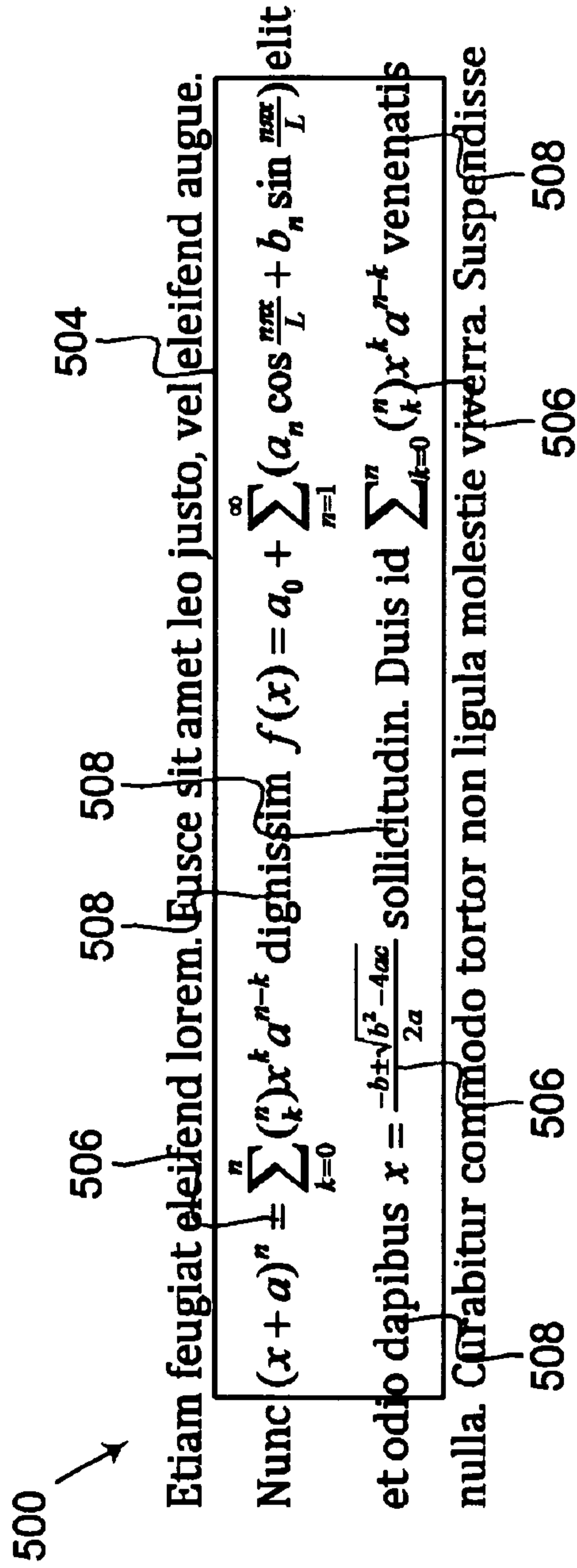

FIG. 5B

7/19

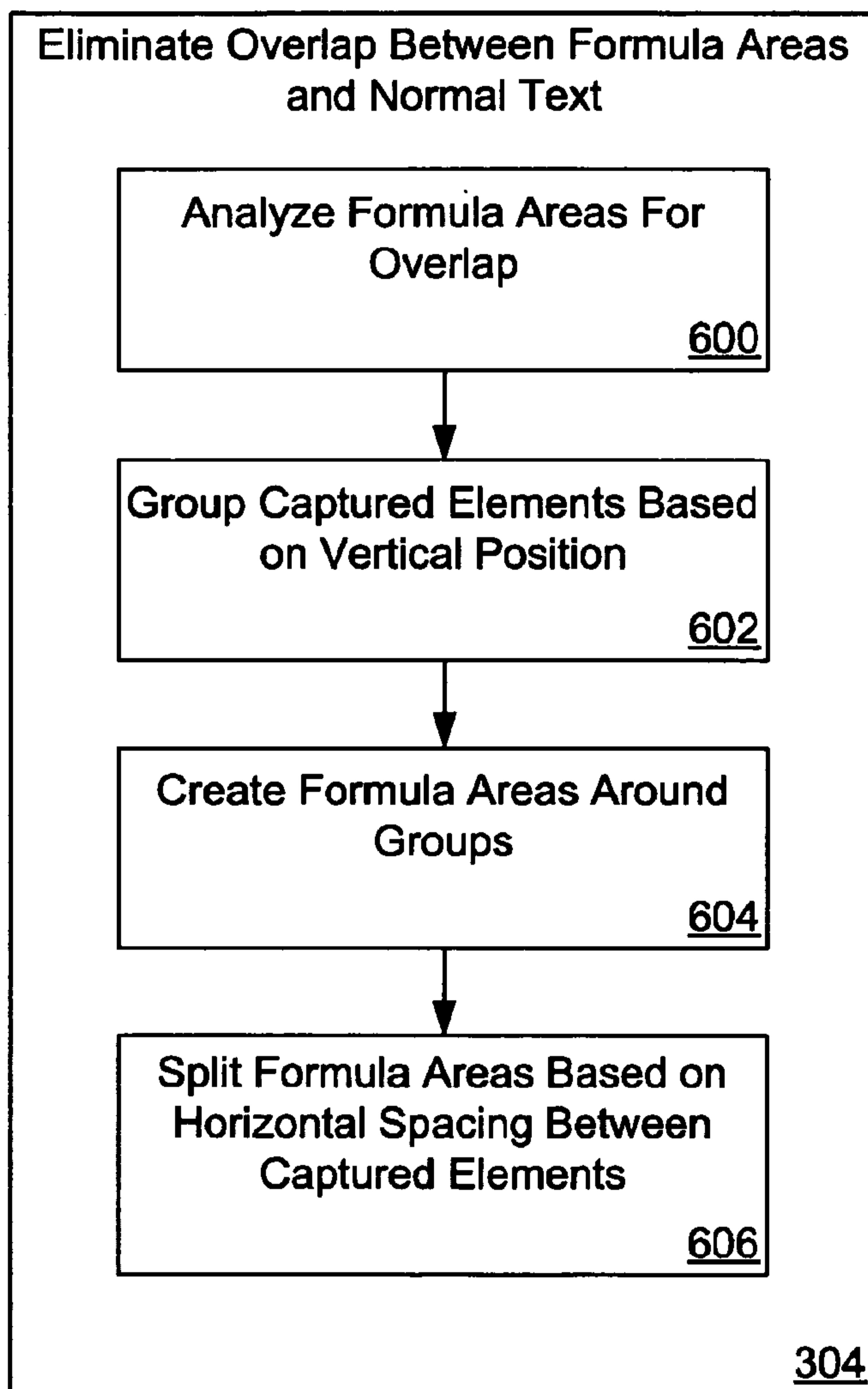

FIG. 6

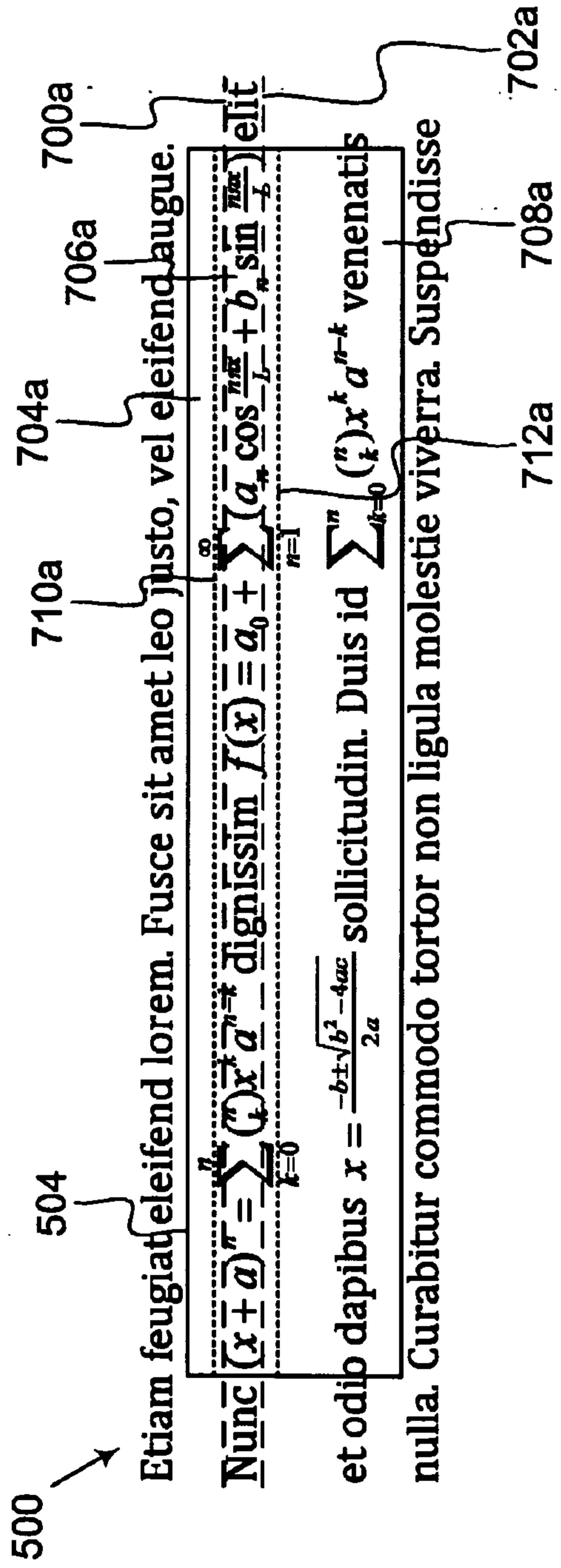

FIG. 7A

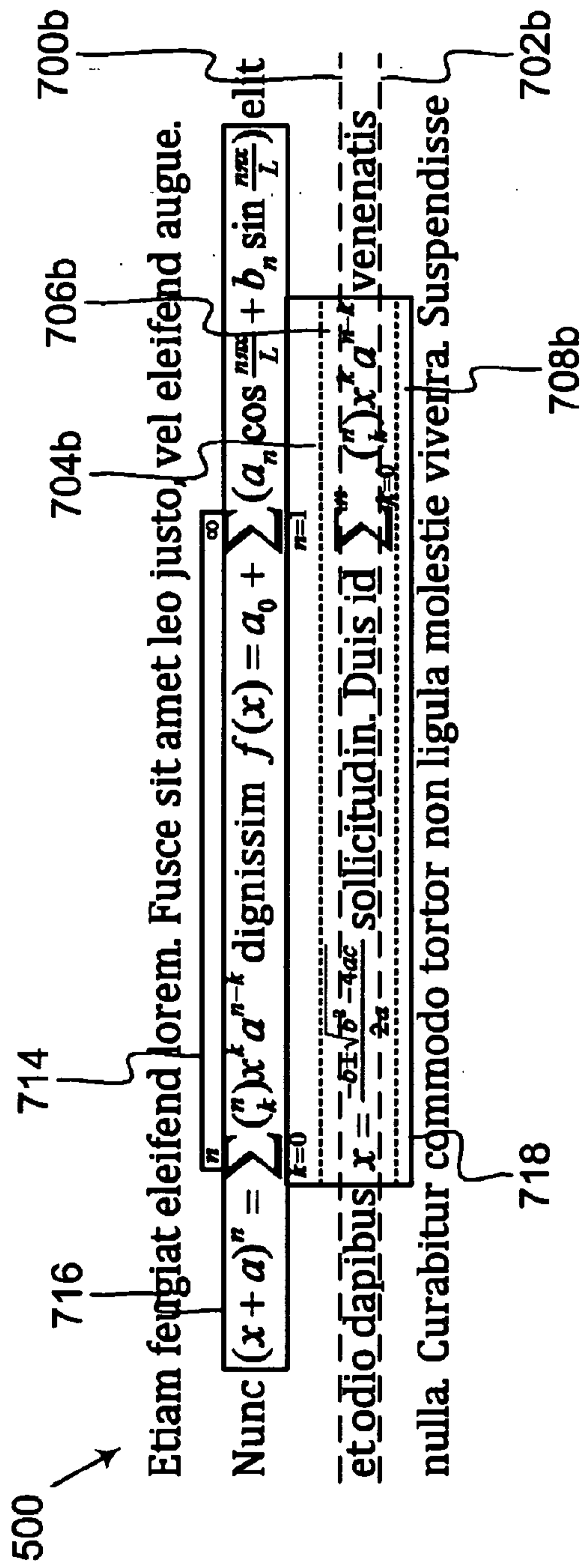

FIG. 7B

500 ↗

716

714

Etiam feugiat eleifend/lorem. Fusce sit amet leo justo, vel eleifend augue.

Nunc $(x+a)^n = \sum_{k=0}^n \binom{n}{k} x^k a^{n-k}$ dignissim $f(x) = a_0 + \sum_{n=1}^{\infty} (a_n \cos \frac{n\pi x}{L} + b_n \sin \frac{n\pi x}{L})$ elit

et odio dapibus $x = \frac{-b \pm \sqrt{b^2 - 4ac}}{2a}$ sollicitudin. Duis id $\sum_{k=0}^n \binom{n}{k} x^k a^{n-k}$ venenatis

nulla. Curabitur commodo tortor non ligula molestie viverra. Suspendisse

724

726

FIG. 7C

500 →

Etiam feugiat eleifend lorem. Fusce sit amet leo justo, vel eleifend augue.

716 730 714 730 730

Nunc $(x+a)^n = \sum_{k=0}^n \binom{n}{k} x^k a^{n-k}$ dignissim $f(x) = a_0 + \sum_{k=1}^m (a_k \cos \frac{n\pi x}{L} + b_n \sin \frac{n\pi x}{L})$ elit

et odio dapibus $x = \frac{-b \pm \sqrt{b^2 - 4ac}}{2a}$ sollicitudin. Duis id $\sum_{k=0}^n \binom{n}{k} x^k a^{n-k}$ venenatis

nulla. Curabitur commodo tortor non ligula molestie viverra. Suspendisse

730 724 730 726

FIG. 7D

12/19

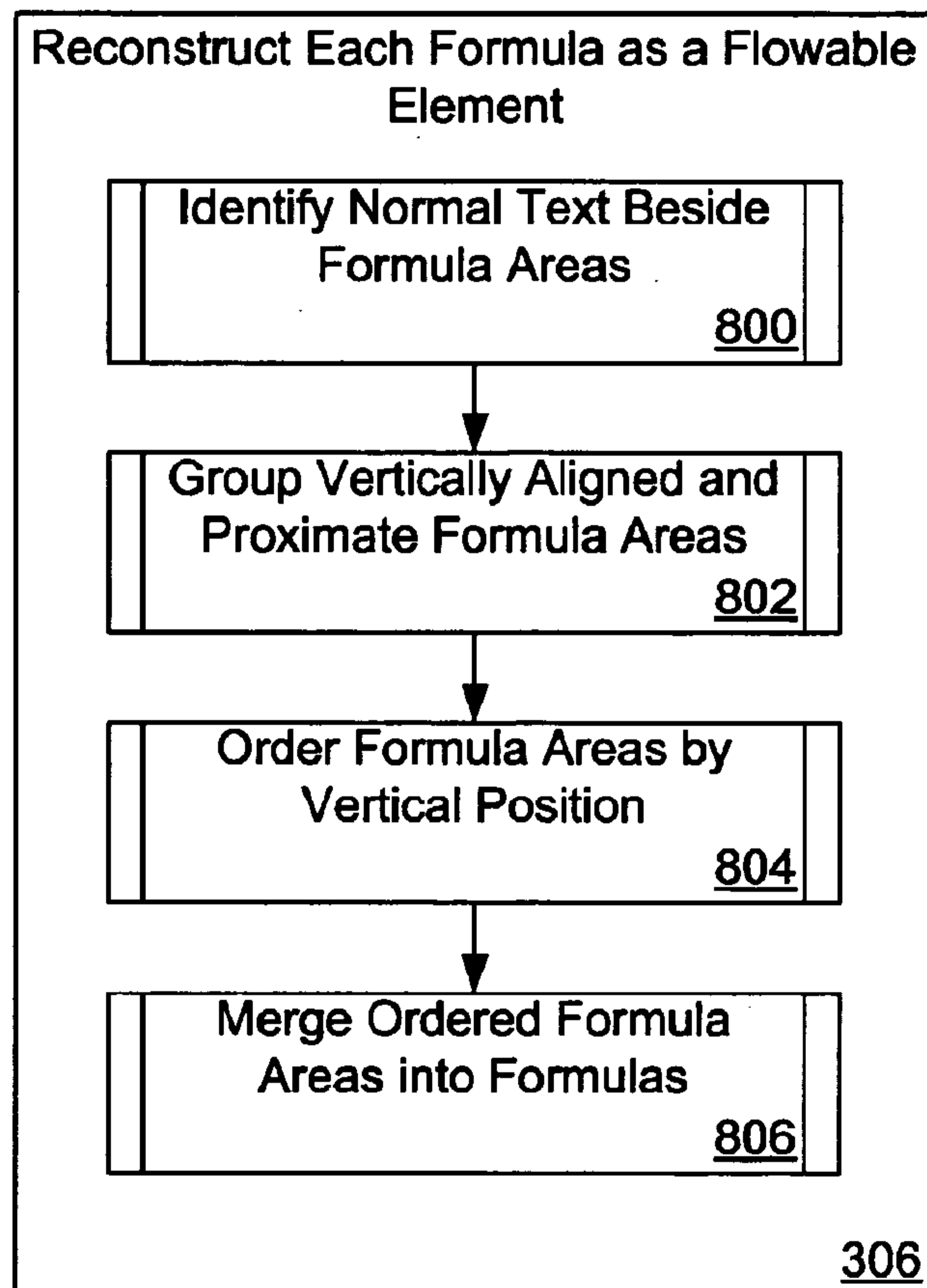

FIG. 8

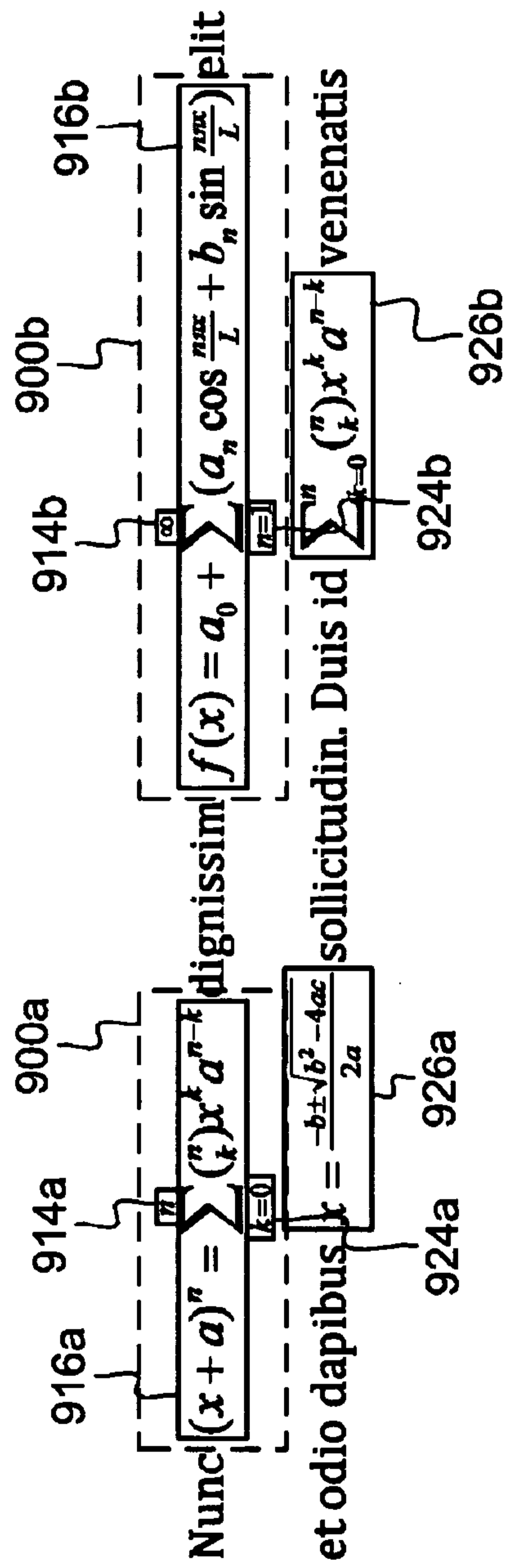

FIG. 9A

902a $(x+a)^n = \sum_{k=0}^n \binom{n}{k} x^k a^{n-k}$ dignissim

et odio dapibus $x = \frac{-b \pm \sqrt{b^2 - 4ac}}{2a}$ 902c

902b $f(x) = a_0 + \sum_{n=1}^{\infty} (a_n \cos \frac{n\pi x}{L} + b_n \sin \frac{n\pi x}{L})$ elit

sollicitudin. Duis id $\sum_{k=0}^n \binom{n}{k} x^k a^{n-k}$ venenatis 902d

FIG. 9B

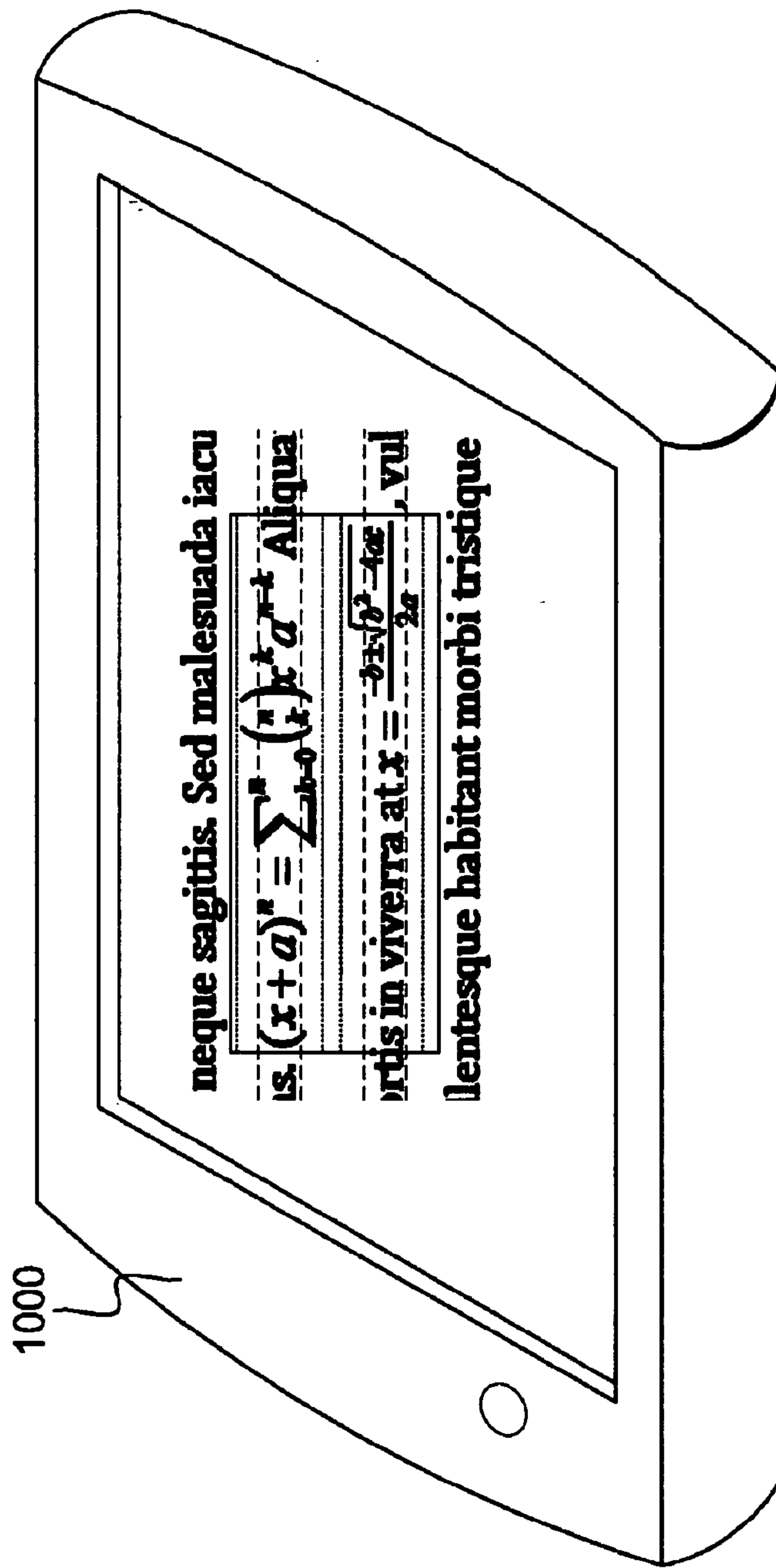

FIG. 10

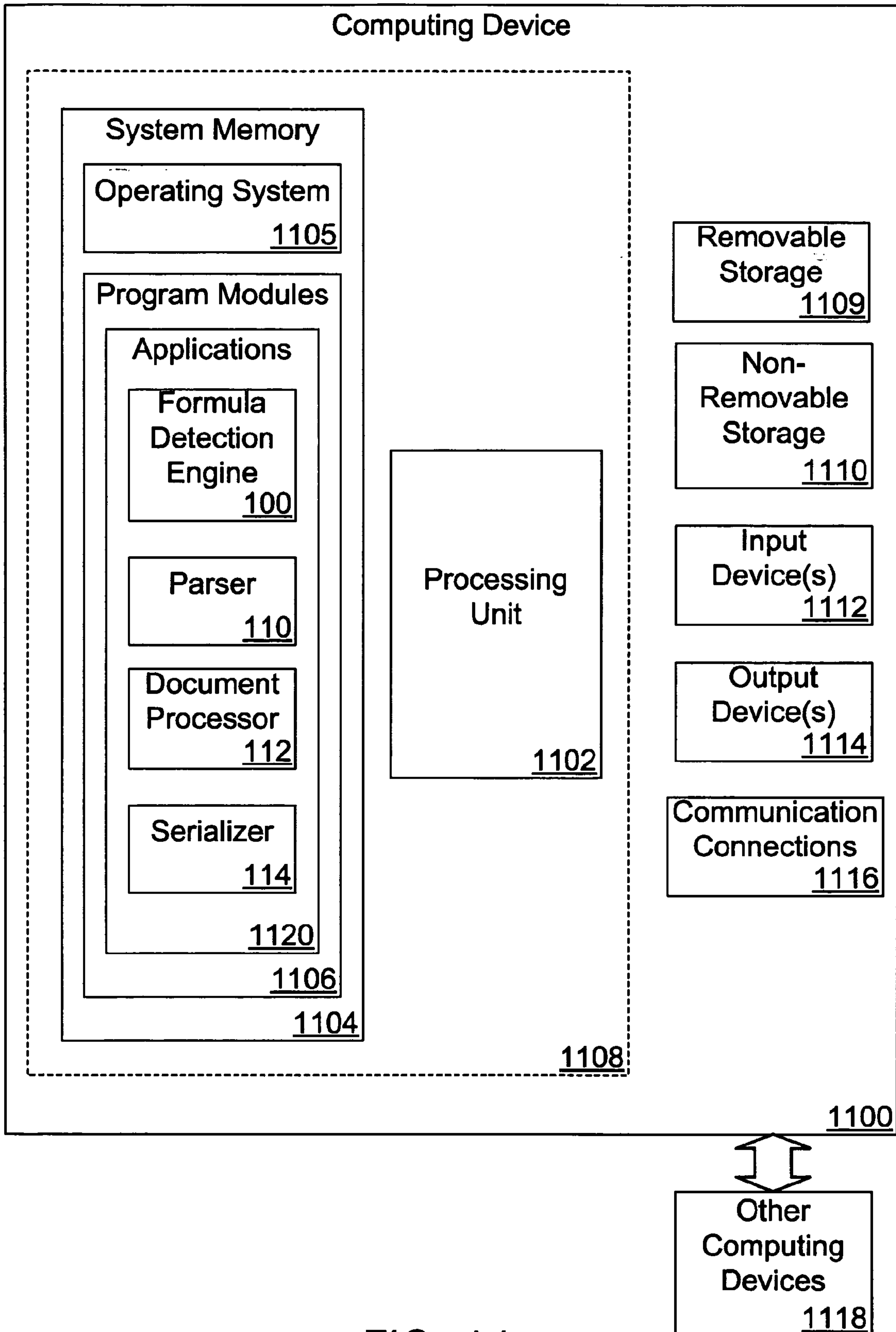
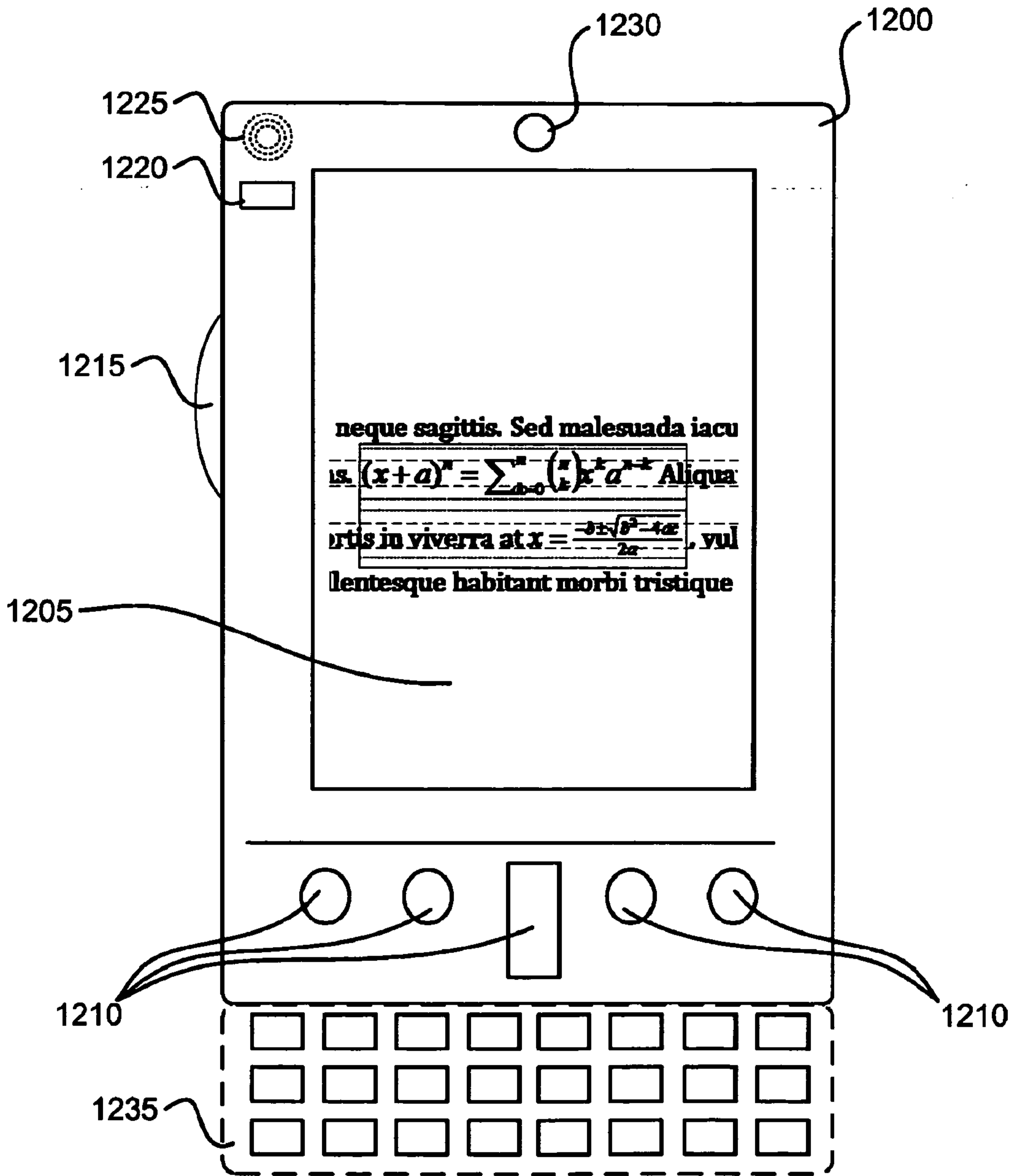

FIG. 11

17/19



Mobile Computing Device

FIG. 12A

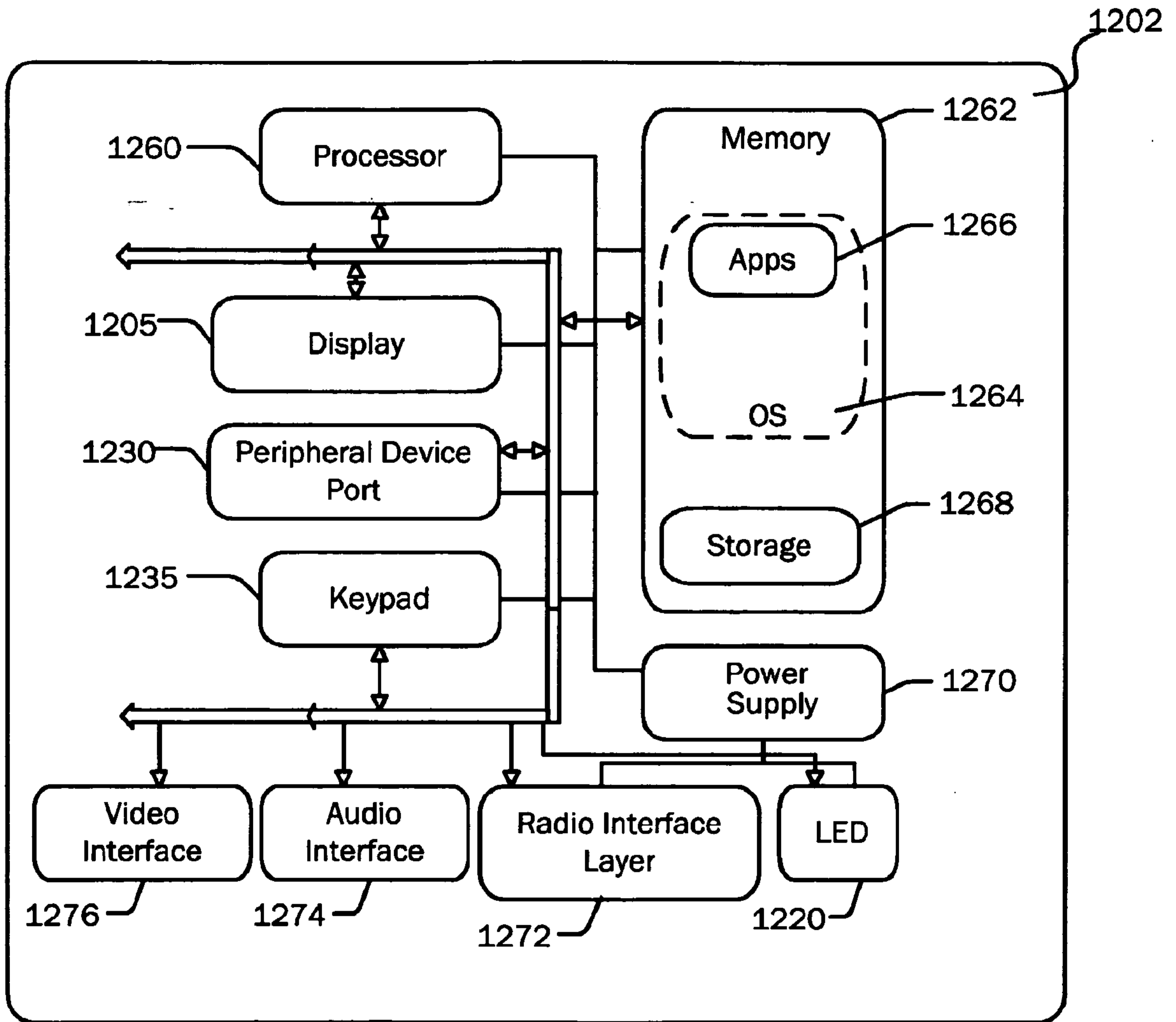

FIG. 12B

19/19

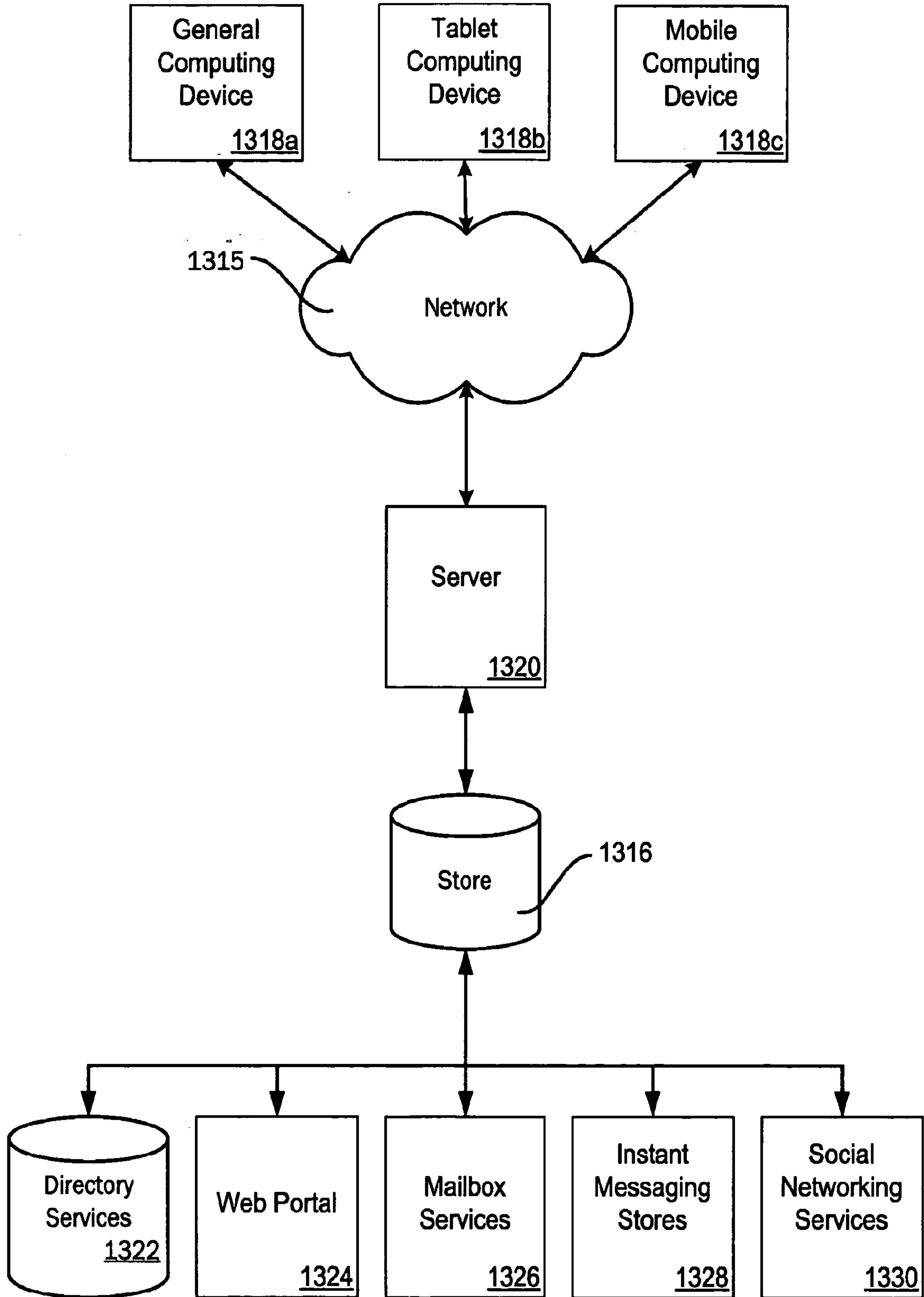

FIG. 13

500

504

710a

704a

706a

700a

Etiam feugiat eleifend lorem. Fusce sit amet leo justo, vel eleifend augue.

Nunc $(x+a)^n = \sum_{k=0}^n \binom{n}{k} x^k a^{n-k}$ dignissim $f(x) \equiv a_0 + \sum_{n=1}^{\infty} (a_n \cos \frac{n\pi x}{L} + b_n \sin \frac{n\pi x}{L})$ elit

et odio dapibus $x = \frac{-b \pm \sqrt{b^2 - 4ac}}{2a}$ sollicitudin. Duis id $\sum_{k=0}^n \binom{n}{k} x^k a^{n-k}$ venenatis

nulla. Curabitur commodo tortor non ligula molestie viverra. Suspendisse

712a

708a

702a