

(12) **UK Patent Application** (19) **GB** (11) **2 317 195** (13) **A**

(43) Date of A Publication 18.03.1998

(21) Application No 9721963.8

(22) Date of Filing 08.08.1995

Date Lodged 16.10.1997

(30) Priority Data

(31) 08288489 (32) 10.08.1994 (33) US
08310862 22.09.1994

(62) Divided from Application No 9516253.3 under Section 15(4) of the Patents Act 1977

(51) INT CL⁶
E21B 10/46

(52) UK CL (Edition P)
E1F FGA F106

(56) Documents Cited
US 5531281 A US 5244039 A

(58) Field of Search
UK CL (Edition P) E1F FFP FGA FGC F106
INT CL⁶ E21B
Online: WPI

(71) Applicant(s)

SMITH INTERNATIONAL INC.

(Incorporated in USA - Delaware)

16740 Hardy Street, Houston, Texas 77032,
United States of America

(72) Inventor(s)

**Graham Mensa-Wilmot
Carl W Keith**

(74) Agent and/or Address for Service

**W H Beck, Greener & Co
7 Stone Buildings, Lincoln's Inn, LONDON, WC2A 3SZ,
United Kingdom**

(54) **A fixed cutter drill bit**

(57) A fixed cutter drill bit (10) includes sets (50) of cutter elements (40) mounted on the bit face (20), each set including at least two cutter elements (40) that are mounted at generally the same radial position with respect to the bit axis. The cutter elements (40) of a set (50) are positioned on different blades (31-36) of the bit (10) and are mounted having their cutting faces (44) out-of-profile, such that certain elements in the set are mounted with differing degrees of backrake. The cutter elements (40) in a set may have equal diameters or may vary in size and shape. The bit (10) exhibits increased stability or vibration resistance, and drills initially as a "light-set" bit and later as a "heavy-set" bit.

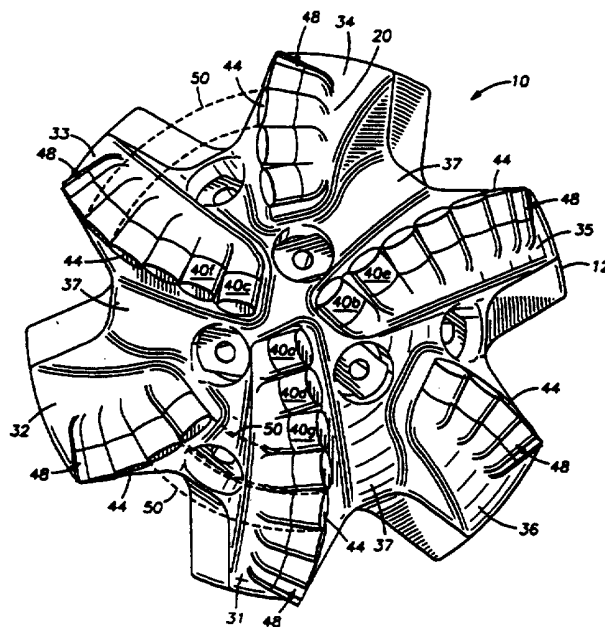

FIG. 2

GB 2 317 195 A

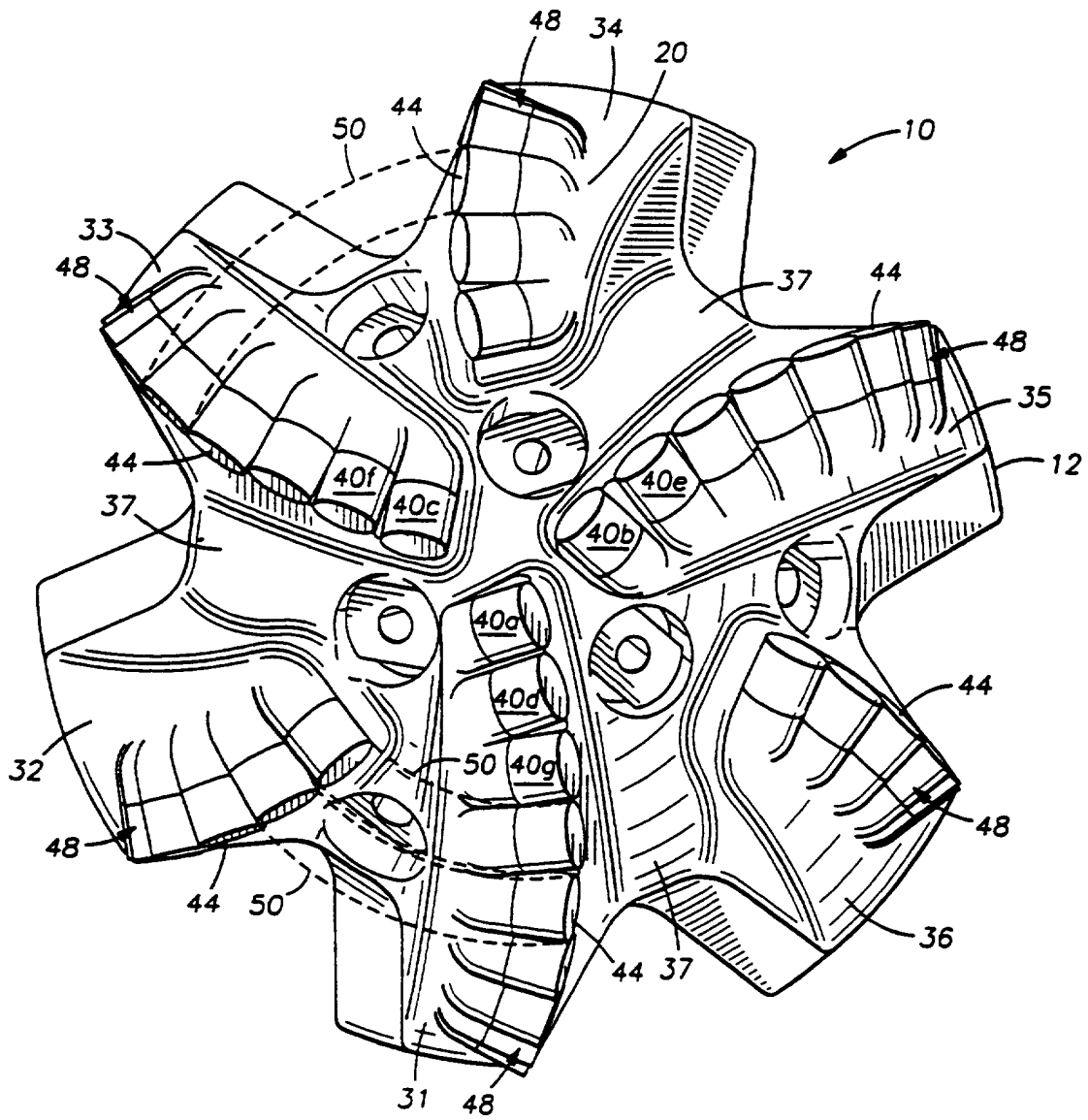

FIG. 2

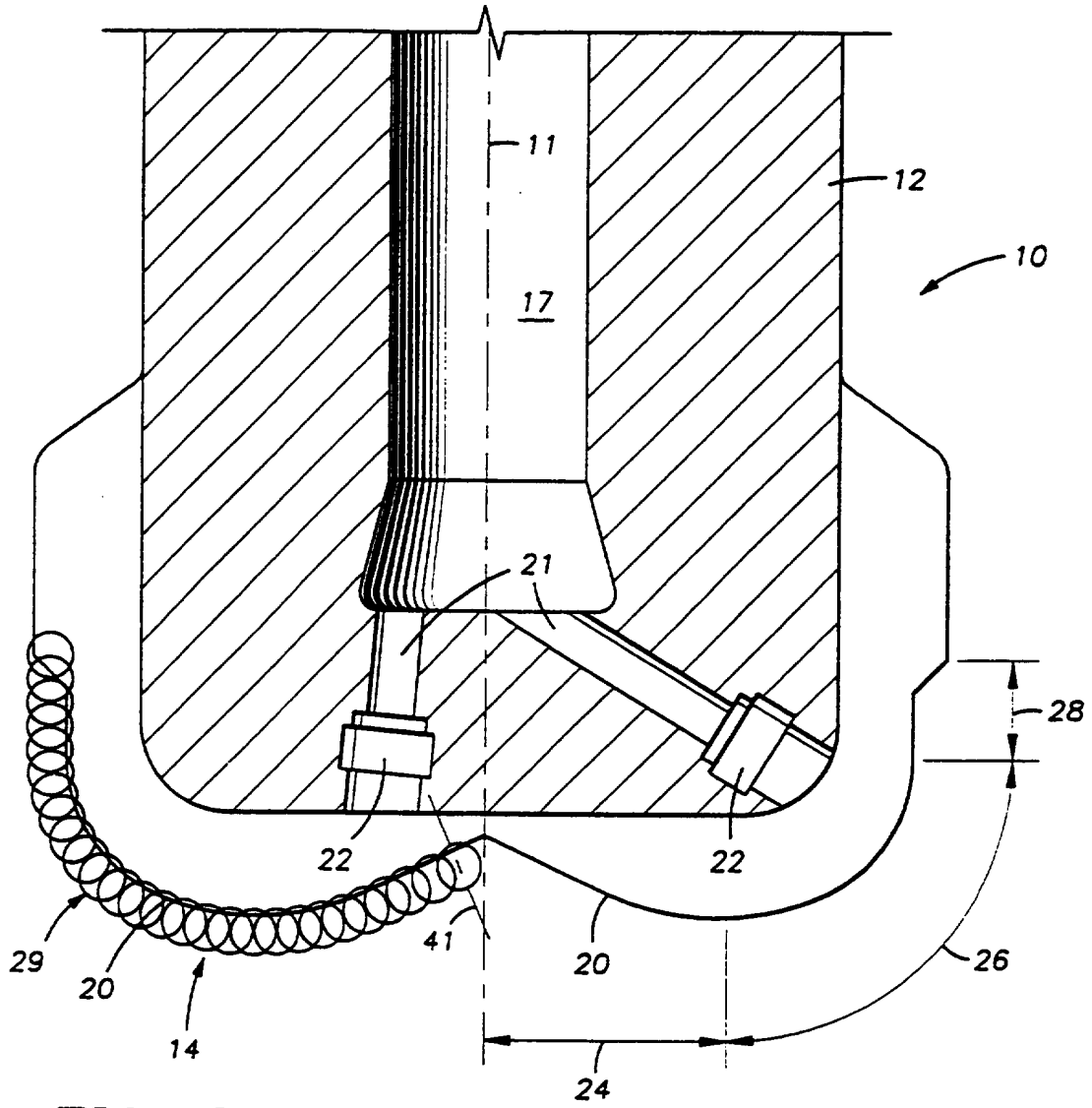

FIG. 3

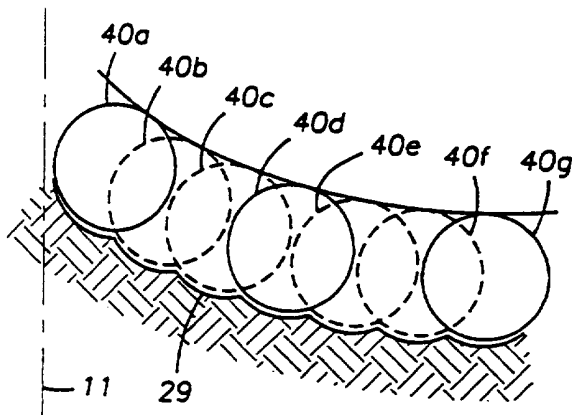

FIG. 4

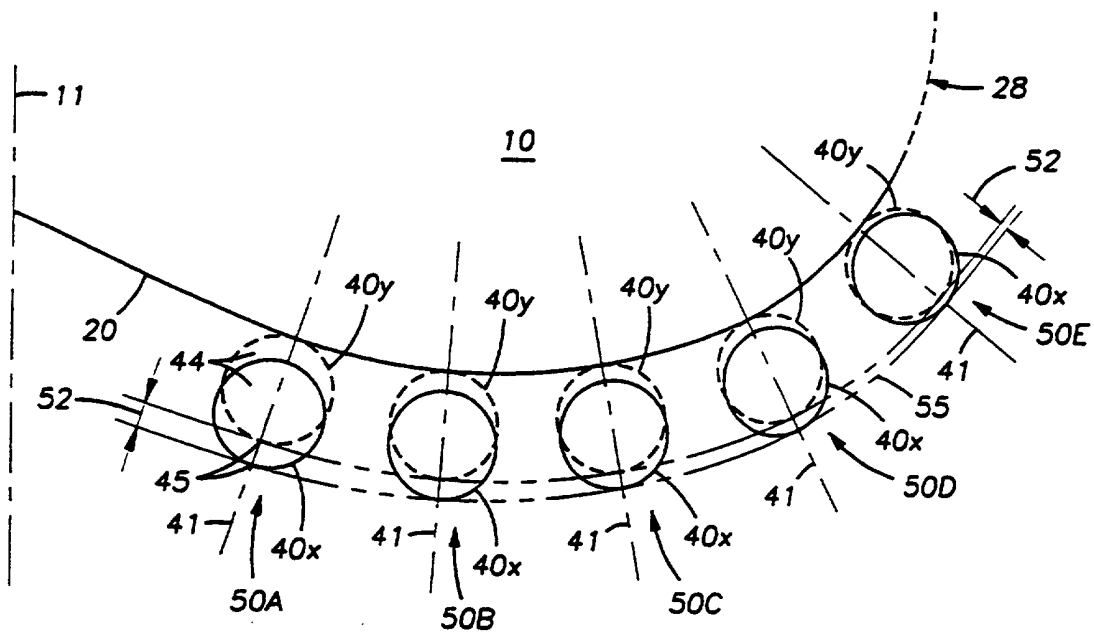

FIG. 5

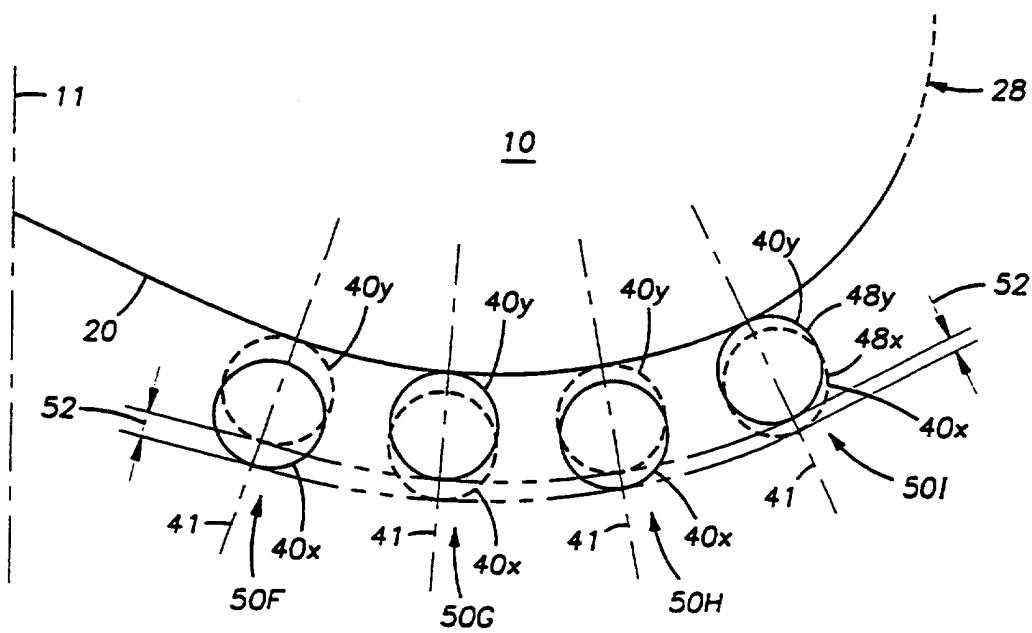
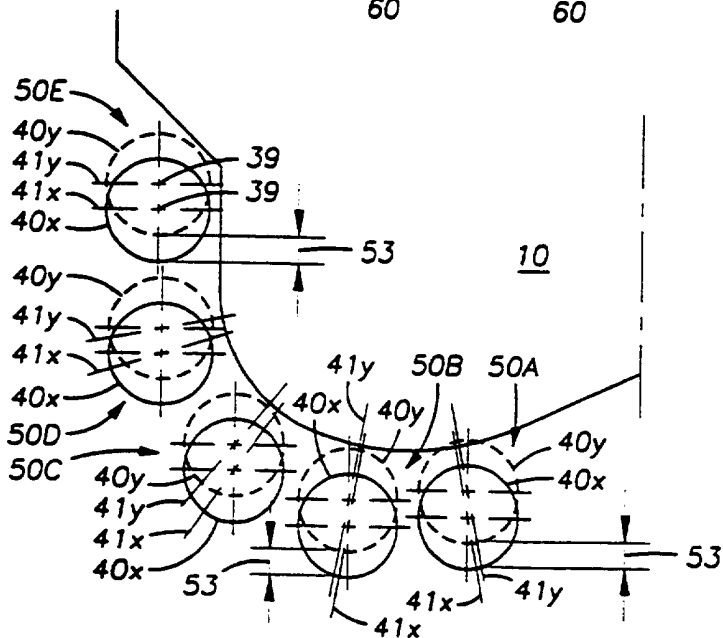
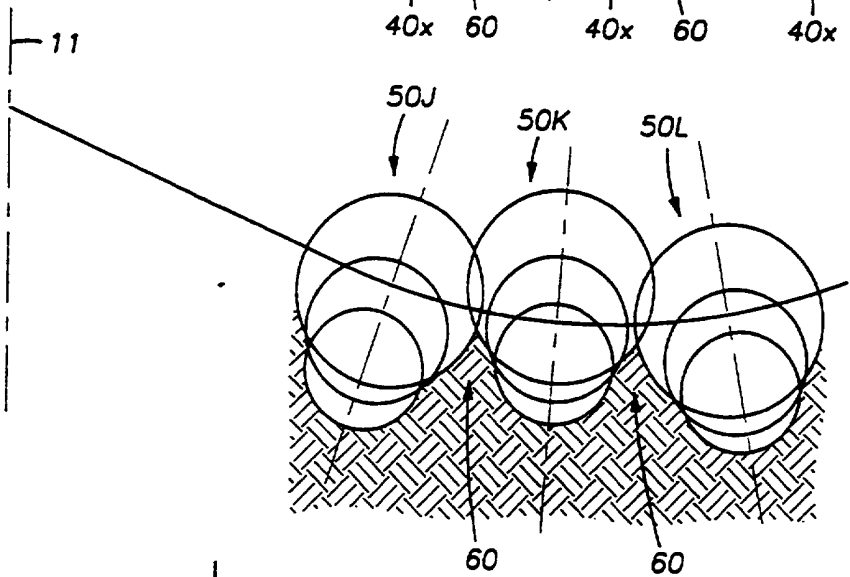
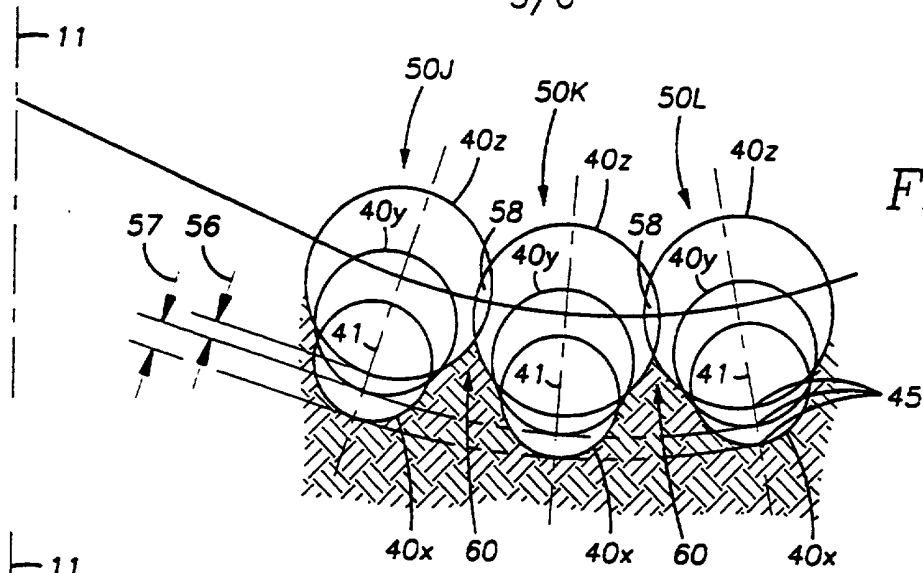

FIG. 6



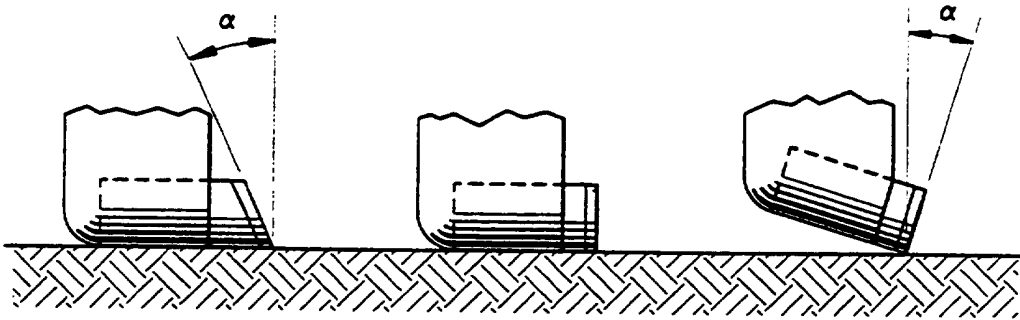

FIG. 10

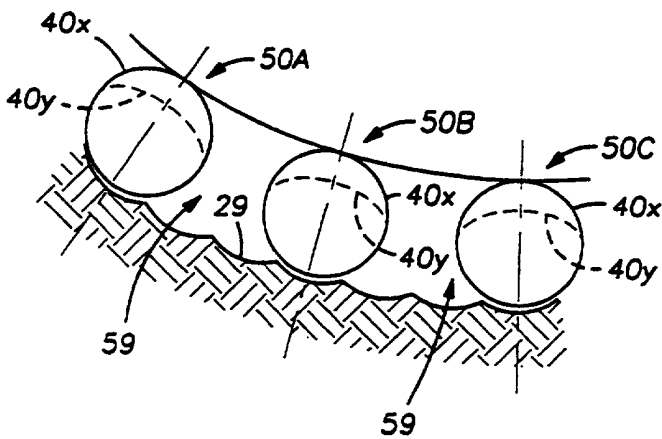

FIG. 11

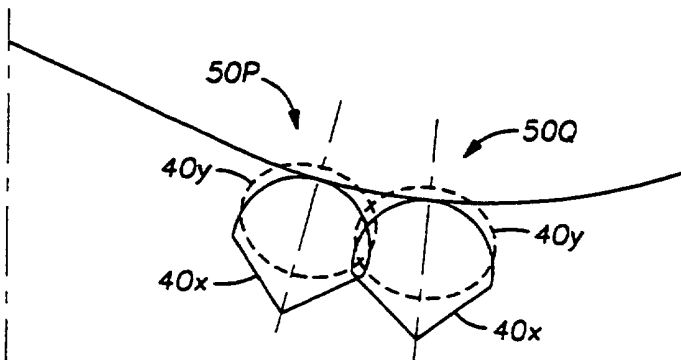

FIG. 12

CUTTING STRUCTURE OF A DRILL BIT
AND A FIXED CUTTER DRILL BIT

5 The present invention relates to a cutting structure
of a drill bit and a fixed cutter drill bit. The present
invention relates generally to fixed cutter drill bits of
the type typically used in cutting rock formation such as
used in drilling an oil well or the like. In a preferred
embodiment, the present invention relates to bits utilizing
10 polycrystalline diamond cutting elements that are mounted
on the face of the drill bit, such bits typically referred
to as "PDC" bits.

In drilling a borehole in the earth, such as for the
recovery of hydrocarbons or for other applications, it is
15 conventional practice to connect a drill bit on the lower
end of an assembly of drill pipe sections which are
connected end-to-end so as to form a "drill string". The
drill string is rotated by apparatus that is positioned on
a drilling platform located at the surface of the borehole.
20 Such apparatus turns the bit and advances it downwardly,
causing the bit to cut through the formation material by
either abrasion, fracturing, or shearing action, or through
a combination of all cutting methods. While the bit is
rotated, drilling fluid is pumped through the drill string
25 and directed out of the drill bit through flow channels
that are formed in the bit. The drilling fluid is provided
to cool the bit and to flush cuttings away from the cutting
structure of the bit and upwardly into the annulus formed
between the drill string and the borehole.

30 Many different types of drill bits and cutting
structures for bits have been developed and found useful in
drilling such boreholes. Such bits include fixed cutter
bits and roller cone bits. The types of cutting structures
include milled tooth bits, tungsten carbide insert ("TCI")
35 bits, PDC bits, and natural diamond bits. The selection of
the appropriate bit and cutting structure for a given
application depends upon many factors. One of the most

important of these factors is the type of formation that is to be drilled, and more particularly, the hardness of the formation that will be encountered. Another important consideration is the range of hardnesses that will be encountered when drilling through layers of differing formation hardness.

Depending upon formation hardness, certain combinations of the above-described bit types and cutting structures will work more efficiently and effectively against the formation than others. For example, a milled tooth bit generally drills relatively quickly and effectively in soft formations, such as those typically encountered at shallow depths. By contrast, milled tooth bits are relatively ineffective in hard rock formations as may be encountered at greater depths. For drilling through such hard formations, roller cone bits having TCI cutting structures have proven to be very effective. For certain hard formations, fixed cutter bits having a natural diamond cutting structure provide the best combination of penetration rate and durability. In formations of soft and medium hardness, fixed cutter bits having a PDC cutting structure are employed with good results.

The cost of drilling a borehole is proportional to the length of time it takes to drill the borehole to the desired depth and location. The drilling time, in turn, is greatly affected by the number of times the drill bit must be changed, in order to reach the targeted formation. This is the case because each time the bit is changed the entire drill string, which may be miles long, must be retrieved from the borehole section by section. Once the drill string has been retrieved and the new bit installed, the bit must be lowered to the bottom of the borehole on the drill string which must be reconstructed again, section by section. As is thus obvious, this process, known as a "trip" of the drill string, requires considerable time, effort and expense. Accordingly, it is always desirable to employ drill bits which will drill faster and longer and

which are usable over a wider range of differing formation hardnesses.

The length of time that a drill bit may be employed before it must be changed depends upon its rate of penetration ("ROP"), as well as its durability or ability to maintain a high or acceptable ROP. Additionally, a desirable characteristic of the bit is that it be "stable" and resist vibration, the most severe type or mode of which is "whirl", which is a term used to describe the phenomenon where a drill bit rotates at the bottom of the borehole about a rotational axis that is offset from the geometric centre of the drill bit. Such whirling subjects the cutting elements on the bit to increased loading, which causes the premature wearing or destruction of the cutting elements and a loss of penetration rate.

In recent years, the PDC bit has become an industry standard for cutting formations of soft and medium hardnesses. The cutting elements used in such bits are formed of extremely hard materials and include a layer of thermally stable polycrystalline diamond material. In the typical PDC bit, each cutter element or assembly comprises an elongate and generally cylindrical support member which is received and secured in a pocket formed in the surface of the bit body. A disk or tablet-shaped, preformed cutting element having a thin, hard cutting layer of polycrystalline diamond is bonded to the exposed end of the support member, which is typically formed of tungsten carbide.

As PDC bits were being developed for use in such harder formations, their cutting structures were designed so as to be "heavy set", which means that the bit was provided with a large number of cutter elements distributed about the face of the bit such that each of the elements would remove a comparatively small amount of material from the formation during each revolution and would be subjected to a loading that was less than the loading that would be experienced by the cutter elements if fewer cutter elements

were provided. This arrangement is to be contrasted with a "light set" bit which had proven successful in softer formations and which has a comparatively fewer number but larger sized cutter elements, each of which would remove a greater volume of formation material than the elements used in a "heavy set" bit.

Because of the difference in design and construction of the heavy set and light set PDC bits, inefficiencies resulted when using one of these bit designs to drill through formations of differing hardness. For example, if a heavy set bit was used for the reason that a lower formation layer had a relatively high degree of hardness compared to a softer upper layer, the heavy set bit tended to clog in the softer formations, resulting in a reduced ROP in that section of the borehole. Alternatively, if a light set bit was used, the ROP in the hard formation was relatively slow in comparison to the rate that could be achieved using a heavy set bit. Thus, where PDC bits were to be used, it was frequently necessary to accept lower ROPs while drilling through formations of one degree of hardness or another, or to trip the drill string and change the drill bits when drilling through formations of differing hardness. Either of these alternatives could be extremely costly.

A common arrangement of the PDC cutting elements was at one time to place them in a spiral configuration. More specifically, the cutter elements were placed at selected radial positions with respect to the central axis of the bit, with each element being placed at a more remote radial position than the preceding element. So positioned, the path of all but the centre-most elements partly overlapped the path of movement of a preceding cutter element as the bit was rotated. Thus, each element would remove a lesser volume of material than would be the case if it were radially positioned so that no overlapping occurred, or occurred to a lesser extent, because the leading cutter element would already have removed some formation material

from the path travelled by the following cutter element. Using this arrangement of cutters, each cutter tended to remove a comparatively small amount of material from the formation during each revolution, and was subjected to
5 substantially the same loading as the other cutter elements on the bit face.

Although the spiral arrangement was once widely employed, this arrangement of cutter elements was found to wear in a manner to cause the bit to assume a cutting
10 profile presenting a relatively flat and single continuous cutting edge from one element to the next. Not only did this decrease the ROP that the bit could provide, but it also increased the likelihood of bit vibration. Both of these conditions are undesirable. A low ROP increases
15 drilling time and cost, and may necessitate a costly trip of the drill string in order to replace the dull bit with a new bit. Excessive bit vibration will itself dull the bit or may damage the bit to an extent that a premature trip of the drill string becomes necessary.

20 Thus, in addition to providing a bit capable of drilling effectively at desirable ROPs through a variety of formation hardnesses, preventing bit vibration and maintaining stability of PDC bits has long been a desirable goal, but one which has not always been achieved. Bit
25 vibration typically may occur in any type of formation, but is most detrimental in the harder formations. As described above, the cutter elements in many prior art PDC bits were positioned in a spiral relationship which, as drilling progressed, wore in a manner which caused the ROP to
30 decrease and which also increased the likelihood of bit vibration.

There have been a number of designs proposed for PDC cutting structures that were meant to provide a PDC bit capable of drilling through a variety of formation
35 hardnesses at effective ROPs and with acceptable bit life or durability. For example, US-A-5033560 (Sawyer et al.) describes a PDC bit having mixed sizes of PDC cutter

elements which were arranged in an attempt to provide improved ROP while maintaining bit durability.

US-A-5033560 is silent as to the ability of the bit to resist vibration and remain stable. Similarly,

5 US-A-5222566 (Taylor et al.) describes a drill bit which employs PDC cutter elements of differing sizes, with the larger size elements employed in a first group of cutters and the smaller size employed in a second group, the patent describing such a bit as tending to act as a "heavy set"
10 bit in certain formations and as a "light set" bit in other softer formations. This design however suffered from the fact that the cutter elements did not share the cutting load equally. Instead, the blade on which the larger sized cutters were grouped was loaded to a greater degree than
15 the blade with the smaller cutter elements. This could lead to blade failure. US-Re-33757 (Weaver) describes still another cutting structure having a first row of relatively sharp, closely-spaced cutter elements, and a following row of widely-spaced, blunt or rounded cutter
20 elements for dislodging the formation material between the kerfs or grooves that are formed by the sharp cutters. While this design was intended to enhance drilling performance, the bit includes no features directed toward stabilizing the bit once wear has commenced. Further, the
25 bit's cutting structure has been found to limit the bit's application to relatively brittle formations.

Separately, other attempts have been made at solving bit vibration. For example, US-Re-34435 (Warren et al.) describes a bit intended to resist vibration that includes
30 a set of cutters which are disposed at an equal radius from the centre of the bit and which extend further from the bit face than the other cutters on the bit. According to that patent, the set of cutters extending furthest from the bit face are provided so as to cut a groove within the
35 formation. By design, the extending cutters ride in the groove which tends to stabilize the bit. Similarly, US-A-5265685 (Keith et al.) discloses a PDC bit that is

designed to cut a series of grooves in the formation such that the resulting ridges formed between each of the concentric grooves tends to stabilize the bit. US-Re-34435 and US-A-5265685 both disclose using the same sized cutter elements. US-A-5238075 (Keith et al.) also describes a PDC bit having a cutter element arrangement which employs cutter elements of different sizes and which, in part, was hoped to provide greater stabilization.

Unfortunately, however, many of these designs aimed at minimizing vibration required that drilling be conducted with an increased weight-on-bit (WOB) as compared with bits of earlier designs. Certain other bits also require substantial additional WOB in order to drill effectively. For example, some bits have been designed with cutters mounted at less aggressive backrake angles such that they require increased WOB in order to penetrate the formation material to the desired extent. Drilling with an increased or heavy WOB has serious consequences and is avoided whenever possible. Increasing the WOB is accomplished by adding additional heavy drill collars to the drill string. This additional weight increases the stress and strain on all drill string components, causes stabilizers to wear more and to work less efficiently, and increases the hydraulic pressure drop in the drill string, requiring the use of higher capacity (and typically higher cost) pumps for circulating the drilling fluid. Compounding the problem still further, the increased WOB causes the bit to wear and become dull much more quickly than would otherwise occur. In order to postpone tripping the drill string, it is common practice to add still additional WOB and to continue drilling with the partially worn and dull bit. The relationship between bit wear and WOB is not linear, but is an exponential one, such that upon exceeding a particular WOB for a given bit, a very small increase in WOB will cause a tremendous increase in bit wear. Thus, adding more WOB so as to drill with a partially worn bit

further escalates the wear on the bit and other drill string components.

Thus, despite attempts and certain advances made in the art, there remains a need for a fitted cutter bit
5 having an improved cutter arrangement which will permit the bit to drill effectively at economical ROPs without excessive WOB and, ideally, in formations having a hardness greater than that in which conventional PDC bits can be employed. More specifically, there is a need for a PDC bit
10 which can drill in soft, medium, medium hard and even in some hard formations while maintaining an aggressive cutter profile so as to maintain acceptable ROPs for acceptable lengths of time and thereby lower the drilling costs presently experienced in the industry. Such a bit should
15 also provide an increased measure of stability as wear occurs on the cutting structure of the bit so as to resist bit vibration. Ideally, the increased stability of the bit should be achieved without having to employ substantial additional WOB and suffering from the costly consequences
20 which arise from drilling with such extra weight.

According to a first aspect of the present invention, there is provided a cutting structure of a drill bit for cutting kerfs in formation material when the bit is rotated about its axis, said cutting structure comprising: a
25 plurality of blades; a set of spaced cutter elements mounted on the bit at substantially the same radial position relative to the bit axis such that each of said cutter elements in said set cuts in substantially the same kerf as the other cutter elements in said set when the bit
30 is rotated about its axis; and, wherein each of said cutter elements of said set is mounted at the leading edge of a different one of said blades and at least one of said cutter elements in said set is mounted with a backrake angle that differs from the backrake angle of other
35 elements in said set.

According to a second aspect of the present invention, there is provided a fixed cutter drill bit for drilling

through formation material when said bit is rotated about its axis, said drill bit comprising: a bit body including a bit face having at least one pair of radially disposed blades, each blade pair including a first blade and a second blade angularly spaced from said first blade, said blades having leading edges for cutting formation material when the bit is rotated; cutter elements disposed in rows on said blades, each of said rows including cutter elements radially spaced from each other relative to the bit axis, said cutter elements in said rows having cutting faces for cutting formation material and an element axis that is normal to said bit face; wherein said cutter elements in said rows are arranged in sets, each of said sets comprising a first cutter element on said first blade and a second cutter element on said second blade having element axes at generally common radial positions relative to the bit axis, said first and second cutter elements being mounted on the leading edge of their respective blades; and, wherein said first cutter element is mounted at a first backrake angle and said second cutter element is mounted at a second backrake angle that is different from said first backrake angle.

Accordingly, there is provided herein a drill bit particularly suited for drilling through a variety of formation hardnesses with normal WOB at improved penetration rates while maintaining stability and resisting bit vibration. In a preferred embodiment, the bit has the characteristics of a light set bit when drilling is initiated and, after some wear has occurred, takes on the characteristics of a heavy set bit, as desirable for drilling through harder formations. The bit may be successfully employed in formations of greater hardness than can typically be drilled using conventional PDC bits.

The cutter elements in a set are mounted on the bit face at generally common radial positions relative to the bit axis, such that the elements in a set tend to follow the same circular path. Each set may consist of two, three

or more cutter elements. The elements in a set may be mounted at varying mounting heights relative to the bit face, such that those elements extending further are more exposed to the formation material than those which are mounted at a relatively lower height from the bit face. A set may include either one or several cutter elements at the same mounting height and having the same cutting profile. In this configuration, certain of the cutter elements in a set are partially hidden from the formation material until a certain degree of bit wear occurs on the more exposed cutter elements. Given this relationship, the bit will initially drill as a light set bit. As drilling progresses, the more exposed cutter elements in a set will gradually wear until the bit takes on the characteristics of a heavy set bit as is useful for drilling in the harder formations.

The cutter elements may be disposed about the bit face in radially extending rows on angularly spaced apart blades of the bit. The higher set or greater exposed elements in a set may all be positioned on a first blade, with lower set and less exposed elements trailing behind it on a second blade angularly displaced from the first. Alternatively, the blades may each include the higher exposed and lower exposed cutter elements which may be disposed in a repeating pattern along the blade so that the blades will be more equally loaded. A particularly desirable pattern is to alternate higher and lower exposed cutter elements along the cutting profile of each blade.

The cutter elements in a set may have cutting faces of equal diameter or, alternatively, may include cutting faces of varying diameters. Where cutters having varying sized cutter faces are employed, the cutter having the smallest cutting face is preferably mounted so as to have the greatest exposure to the formation, while the cutter having the largest cutting face diameter preferably has the least exposure to the formation. This arrangement increases the stability of the bit by creating relatively tall and

sharply tapered ridges between the kerfs which provide the side forces helpful in resisting bit vibration.

The elements in a set are mounted so as to have differing or varying amounts of backrake. In bits
5 employing this feature, the backrake angles of the cutter elements in such a set may typically vary between approximately 10° and 30° negative backrake. The cutter elements having a greater backrake angle may all be
10 positioned on a first blade, with the cutters having less backrake trailing behind it on a second blade angularly displaced from the first. Alternatively, the blades may each include the cutter elements having the greater and lesser amounts of backrake, and may be disposed in a repeating pattern along the blade so that the blades will
15 be more equally loaded. A particularly desirable pattern is to alternate the cutter elements of greater and lesser amounts of backrake along the cutting profile of each blade. The most exposed cutters in a set may either have more or less negative backrake relative to the other
20 cutters in the same set as dependent upon the type of formation being cut.

Thus, the present invention comprises a combination of features and advantages which enable it to substantially
25 advance the drill bit art by providing apparatus for effectively and efficiently drilling through a variety of formation hardnesses at economic rates of penetration and with superior bit durability. The bit drills with less vibration and greater stability, even after substantial wear has occurred to the cutting structure of the bit.
30 Further, drilling with the bit does not also require additional or excessive WOB, permitting drilling to proceed more economically than with many prior art PDC bits. These and various other characteristics and advantages of the present invention will be readily apparent to those skilled
35 in the art upon reading the following detailed description of the preferred embodiments of the invention, and by referring to the accompanying drawings.

For a detailed description of the preferred embodiment of the invention, reference will now be made to the accompanying drawings, wherein:

5 Figure 1 is a perspective view of a drill bit made in accordance with the present invention;

Figure 2 is a plan view of the cutting end of the drill bit shown in Figure 1;

10 Figure 3 is an elevational view, partly in cross-section, of the drill bit shown in Figure 1 with the cutter elements shown in rotated profile collectively on one side of the central axis of the drill bit;

Figure 4 is an enlarged view of a portion of Figure 3 showing the overlapping of the cutting profiles of the cutter elements located adjacent to the bit axis;

15 Figure 5 is an enlarged view similar to Figure 4 showing schematically, in rotated profile, the relative radial positions and exposure heights of the cutter elements that are mounted on the drill bit shown in Figure 1;

20 Figure 6 is a view similar to Figure 5 showing an alternative embodiment of the present invention;

Figures 7, 8 and 9 are views similar to Figures 5 and 6 showing still further alternative embodiments of the present invention;

25 Figure 10 is a schematic view showing cutter elements engaging formation material at various degrees of backrake;

30 Figure 11 is an enlarged view similar to Figure 5 showing schematically, in rotated profile, the relative radial positions and cutting profiles of cutter elements mounted so as to have varying degrees of backrake within the cutter set; and,

Figure 12 is a view similar to Figure 11 showing an alternative embodiment having cutter elements of differing shapes mounted in sets with varying degrees of backrake.

A drill bit 10 embodying the features of the present invention is shown in Figures 1-3. Bit 10 is a fixed cutter bit, sometimes referred to as a drag bit, and is adapted for drilling through formations of rock to form a borehole. Bit 10 generally includes a bit body 12, shank 13, and threaded connection or pin 16 for connecting bit 10 to a drill string (not shown) which is employed to rotate the bit for drilling the borehole. Bit 10 further includes a central axis 11 and a PDC cutting structure 14.

Body 12 includes a central longitudinal bore 17 (Figure 3) for permitting drilling fluid to flow from the drill string into the bit. A pair of oppositely positioned wrench flats 18 (one shown in Figure 1) are formed on the shank 13 and are adapted for fitting a wrench to the bit to apply torque when connecting and disconnecting bit 10 from the drill string.

Bit body 12 includes a bit face 20 which is formed on the end of the bit 10 that is opposite pin 16 and which supports cutting structure 14, described in more detail below. Body 12 is formed in a conventional manner using powdered metal tungsten carbide particles in a binder material to form a hard metal cast matrix. Steel bodied bits, those machined from a steel block rather than a formed matrix, may also be employed in the invention. In the preferred embodiment shown, bit face 20 includes six angularly spaced-apart blades 31-36 which are integrally formed as part of and which extend from body 12. Blades 31-36 extend radially across the bit face 20 and longitudinally along a portion of the periphery of the bit. Blades 31-36 are separated by grooves which define drilling fluid flow courses 37 between and along the cutting faces 44 of the cutter elements 40, which are mounted on bit face 20 and described in more detail below. Again in the preferred embodiment shown in Figure 2, blades 31, 33 and 35 are equally spaced 120° apart, while blades 32, 34 and 36 lag behind blades 31, 33 and 35 by 55°. Given this angular spacing, blades 31-36 may be considered to be

divided into pairs of "leading" and "lagging" blades, a first such pair comprising blades 31 and 32, a second pair comprising blades 33 and 34, and a third pair including blades 35 and 36.

5 As best shown in Figure 3, body 12 is also provided with downwardly extending flow passages 21 having nozzles 22 disposed at their lowermost ends. In the preferred embodiment, bit 10 includes six such flow passages 21 and nozzles 22. The flow passages 21 are in fluid
10 communication with central bore 17. Together, passages 21 and nozzles 22 serve to distribute drilling fluids around the cutter elements 40 for flushing formation cuttings from the bottom of the borehole and away from the cutting faces 44 of cutter elements 40 when drilling.

15 Referring now to Figure 3, to aid in an understanding of the more detailed description which follows, bit face 20 may be said to be divided into three different zones or regions 24, 26, 28. The central portion of the bit face 20 is identified by the reference numeral 24 and may be
20 concave as shown. Adjacent central portion 24 is the shoulder or the upturned curved portion 26 which leads to the gauge portion 28, which is the portion of the bit face 20 which defines the diameter or gauge of the borehole drilled by bit 10. As will be understood by those skilled
25 in the art, regions 24, 26, 28 are approximate and are identified only for the purposes of better describing the distribution of cutter elements 40 over the bit face 20, as well as other inventive features of the present invention.

 As best shown in Figure 1, each cutter element 40 is
30 mounted within a pocket 38 which is formed in the bit face 20 on one of the radially and longitudinally extending blades 31-36. Cutter elements 40 are constructed by conventional methods and each typically includes a generally cylindrical base or support 42 having one end
35 secured within a pocket 38 by brazing or similar means. The support 42 is comprised of a sintered tungsten carbide material having a hardness greater than that of the body

matrix material. Attached to the opposite end of the support 42 is a layer of extremely hard material, preferably a synthetic polycrystalline diamond material, which forms the cutting face 44 of element 40. Such cutter elements 40, generally known as polycrystalline diamond composite compacts, or PDCs, are commercially available from a number of suppliers including, for example, Smith Sii Megadiamond, Inc. or General Electric Company, which markets compacts under the registered trademark STRATAPAX. Although cutters 40 have thus far been shown and described as generally cylindrical elements, the bit 10 and cutting structure 14 of the present invention is not limited to any particular type of cutter element, and stud cutters having cutting faces mounted on posts that are typically fixed normal to the bit face may also be employed.

As shown in Figures 1 and 2, the cutter elements 40 are arranged in separate rows 48 along the blades 31-36 and are positioned along the bit face 20 in the regions previously described as the central portion 24, shoulder 26 and gauge portion 28. The cutting faces 44 of the cutter elements 40 are oriented in the direction of rotation of the drill bit 10 so that the cutting face 44 of each cutter element 40 engages the earth formation as the bit 10 is rotated and forced downwardly through the formation. Cutter elements 40 are mounted on the blades 31-36 in selected radial positions relative to the central axis 11 of the bit 10. Referring momentarily to Figure 3, each of the cutters 40 is positioned with an element mounting axis 41 (one shown in Figure 3) extending normal to the bit face 20.

Referring again to Figures 2 and 3, each row 48 includes a number of cutter elements 40 radially spaced from each other relative to the bit axis 11. As is well known in the art, cutter elements 40 are radially spaced such that the groove or kerf formed by a cutter element 40 overlaps to a degree with kerfs formed by one or more cutter elements 40 of other rows 48. Such overlap is best

understood by referring to Figure 4 which schematically shows, in rotated profile, the relative radial positions of the most centrally located cutter elements 40, that is, those elements 40 positioned closest to bit axis 11 which have been identified in Figures 2 and 4 with the reference characters 40a-40g. As shown, elements 40a, 40d and 40g are radially spaced in a first row 48 on blade 31. As bit 10 is rotated, these elements will cut separate kerfs in the formation material, leaving ridges therebetween. As the bit 10 continues to rotate, cutter elements 40b and 40c, mounted on blades 35 and 33, respectively, will cut the ridge that is left between the kerfs made by cutter elements 40a and 40d. Likewise, elements 40e and 40f (also on blades 35 and 33) cut the ridge between the kerfs formed by elements 40d and 40g. With this radial overlap of cutter 40 profiles, the cutting profile of bit 10 may be generally represented by the relatively smooth curve 29 as shown in Figure 3 which shows the cutter elements 40 of the bit 10 in rotated profile collectively on one side of central bit axis 11.

As will be understood from the disclosure which follows, certain cutter elements 40 are positioned on the bit face 20 at generally the same radial position as other elements 40 and follow in the swath of kerf cut by a preceding cutter element 40. When such "following" elements also have substantially the same exposure height or degree of exposure to the earth formation being drilled, these elements may be referred to as "redundant" cutters. In the rotated profile of Figure 3, the distinction between such redundant cutter elements cannot be seen. Likewise, where cutter elements 40 that are disposed in generally the same radial position are mounted at different exposure heights, or are mounted so as to have varying degrees of backrake, these relatively small differences in exposure height and backrake are not visible in Figure 3, but are described below in more detail with reference to other figures.

In addition to being mounted in rows 48, cutter elements 40 are also arranged in groups or sets 50, each cutter set 50 including cutter elements 40 from various rows 48 that have the same general radial position with respect to bit axis 11. Cutter element sets 50 may include two, three or any greater number of cutter elements 40. In one particularly preferred embodiment of the invention, each cutter set 50 includes two elements 40, each of the elements 40 in the set 50 being located on a different blade 31-36. For illustrative purposes, three of such sets 50 are generally identified in Figure 2. The cutter elements 40 within a set 50 are mounted so as to have varying exposure heights above the bit face 20. Such exposure height variance may be in a direction parallel to the axes 41 of elements 40, as described with reference to Figure 5, or may be in a direction parallel to bit axis 11, as described with reference to Figure 9.

Referring now to Figure 5, five cutter element sets 50A-E are shown in rotated profile in relation to bit axis 11. The cutter elements 40 of a set 50 include cutting faces of substantially equal diameters and are mounted on bit face 20 with their element axes 41 aligned and normal to face 20. Because the bit face 20 is curved, and because the axes 41 of elements 40 are aligned and normal to the bit face 20, cutters 40 in a set 50 do not have exactly the same radial position with respect to bit axis 11, except where the elements' aligned axes 41 are parallel to the bit axis 11. Nevertheless, because the elements 40 in each set 50 cut in the same circular path, the elements may fairly be said to generally have the same or a common radial position. One cutter element 40X in each set 50 is mounted on bit face 20 such that its cutting face 44 is exposed to the formation material below the bit to a greater extent than the other cutter element 40Y of the same set 50. The elements 40X will, at least initially before significant wear occurs, cut deeper swaths or kerfs in the formation material than the less exposed elements 40Y of the set.

This difference in exposure or offset of elements 40X and 40Y measured between the edges of their respective cutting faces 44 can be described as an exposure variance and is identified by reference numeral 52. As shown in the
5 embodiment of Figure 5, the exposure variance 52 preferably decreases with each radially spaced set 50 upon moving from axis 11 toward the gauge portion 28 of bit face 20. As an example, the exposure variance 52 between cutter elements 40X and 40Y of set 50A located in the central portion 24 of
10 bit face 20 is preferably about 1.5mm (about 0.060 inches). For cutter set 50E that is disposed at a location on the shoulder portion 26 of bit face 20, adjacent to gauge portion 28, the exposure variance may be only 0.75mm (0.030 inches).

15 In the embodiment shown in Figure 5, cutter elements 40X and 40Y are mounted on different blades 31-36. For example, referring momentarily to Figure 2, elements 40X are preferably mounted on the blade 32 while elements 40Y are mounted on angularly spaced blade 31 which includes a
20 greater number of cutter elements 40. While this embodiment of the invention is shown in Figures 1 and 2 on a six-bladed bit 10, the principles of the present invention can be employed in bits having any number of blades, and the invention is not limited to a bit having
25 any particular number of blades or angular spacing of the blades. Further, although sets 50 are shown in Figures 2 and 5 as including only two cutter elements 40, the invention may include a greater number of elements in sets 50. Referring generally to Figure 5, the sets 50A-50E may
30 include several cutter elements having the same cutting profile as that of cutter 40X and several others having the same cutting profile as that of cutter element 40Y. For example, bit face 20 may have a cutter set 50A which includes four cutter elements 40 mounted at the same height
35 such that, in rotated profile, all four elements 40 have the same cutting profile as the element designated as 40X. This same set 50A may simultaneously include two cutter

elements 40 that, in rotated profile, have the same cutting profile as that element shown as 40Y. In the embodiment thus described, set 50B may have four cutters having the cutting profile of 40Y and only two having the cutting profile of 40X. It is believed that by providing

5 redundancy with respect to elements 40X and 40Y in a set 50A, and by varying (or alternating for example) the degree of redundancy between adjacent sets 50A and 50B, that even greater bit stability can be achieved.

10 Referring still to Figures 2 and 5, as the bit 10 is rotated about its axis 11, the blades 31-36 sweep around the bottom of the borehole causing the more exposed cutter elements 40X to each cut a trough or kerf within the formation material. As is apparent, the depth of the kerf

15 formed by each cutter element 40X is dependent upon the extent to which the element 40X extends from cutting face 20 of bit 10. Cutter elements 40Y follow in the kerfs cut by the corresponding element 40X. Because elements 40Y are not exposed to the same extent to the formation as elements

20 40X, they are not called upon to cut as great a volume of formation material as do the more exposed elements 40X. In this regard, elements 40Y may be considered partially "hidden" from the formation by elements 40X.

As shown in Figure 5, cutter sets 50A-E are radially

25 spaced from one another such that ridges will be formed as sets 50 cut kerfs in the formation when the bit 10 is rotated. In a similar manner to that described previously with reference to Figure 4, other sets 50 of cutter elements 40 that are mounted on blades 33-36 will follow

30 behind cutter sets 50A-E in a radially overlapping fashion so as to cut the ridges between sets 50A-E and yield a relatively smooth cutting profile 55.

When bit 10 having the cutter arrangement shown in Figure 5 is first placed in the borehole, it has the

35 characteristics of a light set bit. This is because the elements 40Y are at least partially hidden from the formation and perform very little cutting relative to that

performed by cutter elements 40X. As bit 10 is rotated, it is also forced downwardly against the formation material with great force. In relatively soft formations, bit 10 will drill hole with very little wear being experienced by any of the cutter elements 40. As the formation material penetrated by the bit 10 becomes harder, however, elements 40X, which to this point are supporting most of the cutting load, will begin to wear. As drilling continues, elements 40X will eventually wear to the extent that elements 40Y are no longer hidden, such that elements 40X and 40Y will begin to cut substantially equal volumes of formation and will be subjected to substantially equal loading. At this point, the bit 10 has the characteristics of a heavy set bit as is desirable for cutting in harder formations. Also, the combination of elements in sets 50, which in this state of wear include some sharp and some dull cutter elements 40, will tend to reduce vibration and increase bit stability. This arrangement of cutter elements 40 at generally the same radial position but at varying exposures has proven highly successful in soft and medium hardness formations.

Variations or alternative embodiments to the drill bit and cutter arrangement previously described are shown in Figures 6-12. In describing these alternative embodiments, similar reference numerals and characters will be used to identify like or common elements.

Referring now to Figure 9, an alternative embodiment of the invention is shown in which the cutter elements 40 of sets 50 are offset or displaced from one another in a direction that is substantially parallel to bit axis 11. As shown, bit 10 includes cutter element sets 50A-50E. The cutter elements 40 include cutting faces 44 of substantially equal diameters. The cutter elements 40 are mounted on bit face 20 such that the centres 39 of each cutting face 44 in a set 50 are equidistant from bit axis 11. Accordingly, cutter elements 40X and 40Y of each set 50 are positioned at the same radial position with respect to

bit axis 11; however, their element mounting axes, 41X and 41Y respectively, although normal to bit face 20, are not aligned with each other as in the embodiment previously described and shown in Figure 5. Thus, in the arrangement
5 shown in Figure 9, each set 50 includes at least one element 40X that is mounted on bit face 20 such that its cutting face 44, in rotated profile, is offset from the cutting profile of elements 40Y of the same set 50 by an exposure variance designated by the reference numeral 53.
10 In this embodiment, the exposure variance 53 of cutter sets 50A-50E will all be identical, and may be, for example, approximately 1.5mm (approximately 0.060 inches).

Referring now to Figure 6, bit 10 is shown to include four cutter sets 50F-I mounted on bit face 20 in radially-spaced relationship relative to bit axis 11. Each cutter
15 set 50 includes a pair of cutter elements 40 having generally the same radial position and having cutting faces 44 of substantially the same diameter. Each cutter set 50 includes an element 40X that is exposed to a greater degree
20 to the formation than the other element 40Y. Elements 40X and 40Y are mounted on bit face 20 with their element axes aligned and normal to face 20. In this embodiment, however, each blade 31-36 includes both types of elements 40X and 40Y mounted in alternating offset fashion along its
25 radial length. More specifically, a first blade, for example, blade 32 (Figure 2) is shown to include a row 48X of cutter elements 40 arranged so as to have the cutting profile shown in Figure 6 by the cutting faces 44 depicted with the solid lines. A second blade, such as blade 31
30 (Figure 2) will follow behind blade 32 and will have row 48Y of cutter elements arranged so as to have the cutter profile shown by the cutting faces 44 represented by the dashed lines. As is apparent, the arrangement of alternating highly exposed and less exposed cutter elements
35 40X and 40Y are reversed when comparing rows 48X and 48Y. As with the embodiment shown in Figure 5, the exposure variance 52 between the cutting faces 44 of elements 40X

and 40Y decreases across the cutting profile of bit 10 upon moving from axis 11 toward gauge portion 28 of bit face 20.

Like the embodiment shown and described with reference to Figure 5, the bit 10 of Figure 6 initially has the characteristics of a light set bit given that one half of the total number of cutter elements 40 (elements 40Y) are partially hidden by the more exposed cutters 40X until harder formations wear elements 40X. When such wear occurs, the bit 10 assumes the characteristic of a heavy set bit where all cutter elements 40X and 40Y cut substantially equal volumes and generally share the loading equally. The alternating pattern of elements 40X and 40Y along rows 48 on blades 31-36 enable each blade 31-36 to share the load equally through out the drilling process. Thus, the embodiment of Figure 6 has the additional advantage that the blades 31-36 are all substantially evenly loaded such that one blade is not required to endure most of the loading until cutter elements 40X wear, as is the case with the bit 10 described with reference to Figure 5.

Substantially the same equal loading on blades 31-36 can be achieved through other alternating patterns of highly exposed and lesser exposed cutter elements 40X and 40Y. For example, beginning at a particular radial position and moving outwardly toward the gauge portion 28 of the bit face 20, a blade 32 may include a row 48 of radially-spaced cutters 40 having the following pattern: 40X, 40X, 40Y, 40Y, 40X, 40X. In this example, the following blade 31 would then be provided with a corresponding row 48 having the following cutter pattern: 40Y, 40Y, 40X, 40X, 40Y, 40Y. As will be appreciated by those skilled in the art, a number of other similar patterns can also be employed.

Another alternative embodiment of the invention is shown in Figure 7. As shown, bit 10 includes a number of radially spaced cutter element sets 50J-L. Cutter elements 40 within the same set 50 have generally the same radial

position with respect to bit axis 11 and have their element axes 41 aligned and normal to bit face 20. Elements 40 of sets 50 are mounted at different heights on bit face 20 so as to create varying exposures for the elements 40 with respect to the formation that is being drilled. The cutter elements 40 having the greatest exposure are identified by reference character 40X. The cutter elements having the least exposure are shown as elements 40Z. Elements of intermediate exposure are identified by the reference character 40Y. The exposure variance between element 40Z and 40Y is represented by reference numeral 56. The exposure variance between element 40Y and 40Z is shown by reference numeral 57. Although such variances may vary, variances 56 and 57 may be, for example, approximately 0.75mm and 0.75mm (0.030 and 0.030 inches) respectively for sets 50 located in the central portion 24 of the bit face 20. Once again, these variances 56 and 57 will decrease upon moving away from bit axis 11 toward gauge surface 28.

It is preferred that elements 40X, Y and Z have cutting faces 44 of different diameters. Ideally, elements 40X should have the smallest diameter while elements 40Z, which are positioned closest to the bit face 20 and have the smallest initial exposure to the formation have the largest diameter. As an example of acceptable cutter sizes, cutter elements 40X may have cutting faces having diameters of 3/4 inch (approximately 19mm), with the cutting faces of cutter elements 40Y and 40Z having diameters of 5/8 inch (approximately 16mm) and 1/2 inch (approximately 13mm), respectively. Additionally, cutter elements 40Z in adjacent radially spaced sets 50 will be positioned such that their cutting face profiles overlap, so as to form a region 58 of double cutter density.

The elements 40X, Y and Z in each set 50 are divided among a number of blades 31-36 on bit face 20. Obviously, for a three element set 50 as shown in Figure 7, bit 10 will require at least three blades. Because the cutting profiles of cutter elements 40Z overlap radially and could

therefore not be mounted in the same row 48 on the same blade, and so as to provide for more equal loading on all the blades, elements 40 are divided among the blades. For example, a first blade 31 may include a row 48 having
5 radially spaced elements 40Z of cutter set 50J, 40Y of set 50K, and 40X of set 50L. The next blade 32 may include element 40X of set 50J, element 40Z of set 50K and element 40Y of set 50L. The third blade 33 would then include element 40Y of set 50J, element 40X of set 50K and element
10 40Z of set 50L.

The cutter element arrangement thus described and shown in rotated profile in Figure 7 will create relatively high ridges between the cutter sets 50 in the regions designated by reference numeral 60. These ridges will tend
15 to be higher than those created by the cutting element arrangement previously described herein. The arrangement of elements 40 shown in Figure 7 will tend to be highly resistant to lateral movement of the bit 10 due to the increased side loading from the ridges. The bit 10 will
20 thus tend to remain stable and resist bit vibration. Additionally, the bit 10 of Figure 7 exhibits increased penetration rates in varying formation hardnesses, the bit initially having the characteristics of a light set and later taking on those characteristics of a heavy set bit as
25 the more exposed elements 40X, and later, 40Y wear.

Although sets 50J-L are depicted in Figure 7 as consisting of three elements 40 per set, the invention is in no way limited to any specific number of cutter elements 40 in a set 50. That is, a set 50 may include two, three
30 or more elements 40 in the same set 50. Also, although each set 50 is shown in Figure 7 to include an equal number of cutter elements 40, the number of cutter elements 40 in the sets may vary on the same bit. For example, it may be desirable to have a greater number of cutter elements 40 in
35 a set 50 that is located at a particular radial position on the bit face 20 that is subjected to greater loading than a radial position that is not as highly loaded. Also, sets

50 may include any desired number of redundant cutters in the positions shown by cutters 40X, 40Y and 40Z in Figure 7, as previously described with respect to Figure 5.

5 Still another alternative embodiment of the present invention is shown in Figure 8. In this embodiment, radially adjacent cutter sets 50J-L themselves have varying degrees of exposure. More specifically, cutter elements 40X, Y and Z of sets 50J and 50L are mounted so as to protrude further from the bit face 20 than the
10 corresponding cutter elements of set 50K. This bit 10 produces even higher ridges of formation material in region 62 than the arrangement described with reference to Figure 7. The ridges in region 62 between cutter sets 50 again produce increased side loading relative to conventional
15 bits, thereby increasing the stability of the bit and resisting bit vibration.

As mentioned previously, elements 40 may be mounted such that their cutting faces 44 engage the formation material with varying degrees of "backrake". Referring
20 momentarily to Figure 10, three cutters 40 having cutting faces 44 are shown mounted on a bit with different backrake angles. Backrake may generally be defined as the angle α formed between the cutting face of the cutter element 40 and a line that is normal to the formation material being
25 cut. As shown, with a cutter element having zero backrake, the cutting face 44 is substantially perpendicular or normal to the formation material. A cutter having a negative backrake angle α has a cutting face that engages the formation material at an angle that is less than 90° as
30 measured from the formation material. Similarly, a cutter element 40 having a positive backrake angle α has a cutting face which engages the formation material at an angle that is greater than 90° when measured from the formation material as depicted in Figure 10.

35 Referring now to Figure 11, cutter element sets 50A-C, previously shown in Figure 5, are depicted with each set having a cutter element 40x and 40y mounted with differing

degrees of backrake. More specifically, in the embodiment shown in Figure 11, cutter elements 40x mounted on the face of blade 31 have a negative backrake angle of substantially 10°. Cutter elements 40y shown mounted on the face of angularly-spaced blade 32 have a negative backrake angle of substantially 30°.

As depicted in Figure 11, the cutting profile of elements 40x are substantially circular given their very slight degree of backrake. By contrast, the cutting profile of elements of 40y, which have a greater degree of negative backrake, appear more elliptical. In this arrangement, cutter elements 40x on leading blade 31 are said to have a more aggressive backrake angle as compared with the cutter elements 40y on lagging blade 32. Although not shown in Figure 11, it will be understood that additional sets 50 of cutters 40 will be positioned on bit face 20 at radial positions between sets 50A and 50B and between sets 50B and 50C so as to cut the formation material in the regions generally identified by reference numeral 59. These additional cutter sets, which would be mounted on blades 33-36 in this example, are not shown in Figure 11 for the sake of clarity.

Furthermore, although sets 50A-C are shown in Figure 11 as including only two cutter elements 40, the invention preferably includes a greater number of elements in sets 50. For example, a cutting structure 14 on bit face 20 may include a cutter set 50A having three cutter elements 40 mounted with 10° of backrake such that, in rotated profile, all three such elements 40 would have the same cutting profile as the element designated as 40x. These three elements having the cutting profile of 40x shown in Figure 11 may be separately mounted on blades 31, 33 and 35 (Figure 2). This same set 50A may simultaneously include three cutter elements 40 mounted with the same 30° backrake such that, in rotated profile, they will have the same cutting profile as that element shown as 40y. The cutters

having the profile of 40y could be individually mounted on blades 32, 34 and 36.

5 An arrangement as thus described having a cutting structure 14 with sets 50 having three redundant aggressive cutters 40x and three redundant cutters 40y mounted at a less aggressive backrake angle has particular benefits and advantages over prior art bits. The cutting structure will permit the bit to drill effectively in a variety of formation hardnesses at high ROPs, both when the bit is new and as wear occurs. Further, providing a plurality of cutter elements 40 in sets 50 at substantially the same radial position and positioning these sets across the bit face 20 will provide a stabilizing effect to the bit without the need for additional WOB.

15 Although cutter elements 40x and 40y in Figure 6 have been described as being segregated by blade, another alternative embodiment of the invention provides that various of the elements 40x and 40y will be mounted on the same blade in a variety of patterns. This arrangement allows equalizing the loading on the blades. Additionally, although the cutter elements shown in Figure 11 are all mounted at generally the same exposure height, the mounting height of elements 40x and 40y in a set 50A-C may be varied to allow the bit to initially drill as a light set bit, and later as a heavy set bit. In short, the cutter elements 40x and 40y in cutter sets 50 in any of the embodiments previously described with respect to Figures 5-9 may be mounted so as to have varying degrees of backrake. For example, referring to Figure 5, elements 40y may be mounted so as to have a negative backrake angle of substantially 30° while cutter elements 40x may have a more aggressive backrake angle, such as a negative backrake angle of substantially 10°. In this embodiment, due to their respective backrake angles, the cutting profile of cutter elements of 40x would be substantially circular, while the cutting profiles of 40y would be more elliptical. Cutter elements 40x, at least until some degree of significant

wear had occurred, would cut deeper swaths or kerfs in a formation material than less exposed elements 40y of the set. The exposure variance 52, in this embodiment, would preferably decrease with each radially spaced set 50 upon moving from axis 11 toward gauge portion 28 of bit face 20. Providing elements 40x, 40y with differing degrees of backrake within the same set 50, along with the fact that the sets 50, after some wear has occurred, include some relatively sharp cutters 40y and some relatively dull cutters 40x, synergistically combined to reduce vibration and increase bit stability. This arrangement of cutter elements 40 of generally the same radial position having varying degrees of backrake and exposure height is believed to be particularly advantageous for use in drilling intervals of differing formations that have varying degrees of formation hardness and strength.

Referring again to Figure 6, each blade 31-36 may include elements 40x and 40y having differing degrees to backrake mounted in alternating fashion along the blade's radial length. For example, a first blade, for example blade 31 shown in Figure 2, may include a row 48 of radially spaced cutter elements 40 mounted so as to have the cutting profiles shown in Figure 6 by the cutting faces 44 depicted with solid lines. A second blade, such as blade 32 will follow behind blade 31 and will have a row of cutter elements spaced so as to have the cutter profile shown by the cutting faces 44 represented by the dash lines. Elements 40x and 40y may be mounted such that elements 40x have a negative backrake angle of approximately 10° , while elements 40y have a negative backrake angle of substantially 30° . The exposure variance 52 between the cutting faces 44 of elements 40x and 40y decreases upon moving from axis 11 towards gauge portion 28. Initially, this bit would have a characteristics of a light set bit given that one-half of the total number of cutter elements (elements 40y) are partially hidden by the more exposed cutters 40x until the formation wears the more

exposed and more aggressive (less backrake angle) elements 40x. The alternating pattern of elements 40x and 40y mounted in rows 48 on blades 31-36 enable each blade 31-36 to share the load equally throughout the drilling process. Thus, varying the backrake angles of the cutters 40 in the embodiment shown in Figure 6 has the additional advantage over that of Figure 5 in that blades 31-36 are all substantially evenly loaded, such that one blade is not required to endure most of the loading until the time that cutter elements 40x wear, as would be the case with a cutting structure such as that shown in Figure 5.

Substantially the same equal loading on blades 31-36 can be achieved through other alternating patterns of elements 40x (highly exposed, less backrake) and 40y (less exposed, more backrake). For example, beginning at a particular radial position and moving outwardly toward the gauge portion 28 of the bit face 20, a blade 31 may include a row 48 of radially-spaced cutters 40 having the following pattern: 40x, 40x, 40y, 40y, 40x, 40x. In this example, the following blade 32 would then be provided with a corresponding row 48 having cutter elements positioned at substantially the same radial position as the cutters just described for blade 31 and in the following cutter pattern: 40y, 40y, 40x, 40x, 40y, 40y. As will be appreciated by those skilled in the art, a number of other similar patterns can also be employed. Also, it should be understood that in certain formations, it may be more desirable to mount the cutter elements that are more exposed with less backrake than the lesser exposed elements.

Referring again to the embodiments shown in Figure 7 and 8, the cutter elements 40 within each set 50 may again have varying degrees to backrake. In these embodiments, it is preferred that the smaller and more exposed elements 40x have a negative backrake of substantially 10° and the larger and less exposed elements 40z have a negative

backrake angle of substantially 30°. Elements 40y are mounted as so to have approximately 20° negative backrake.

5 Finally, although the preferred embodiments described herein have been depicted and described with reference to cutters 40 having circular cutting faces, it should be understood that the invention is not limited to cutters 40 having any particular shape of cutting profile. For example, referring to Figure 12, a bit 10 structured in accordance with the present invention is shown with cutter sets 50P and 50Q in rotated profile. Each set includes a more highly exposed cutter element 40x, and a lesser exposed element 40y. Elements 40x are scribe cutters having cutting points or tips 45 and are mounted with backrake angles of substantially 10°. By contrast, 10 elements 40y are round-faced cutters that are mounted at a less aggressive backrake angle of approximately 30°. Various other combinations of mounting height, cutter shape and backrake angles can be employed to enjoy the substantial benefits that are offered by the present 15 invention.

20 While the preferred embodiments of the invention have been shown and described, modifications thereof can be made by one skilled in the art. The embodiments described herein are exemplary only, and are not limiting. Many 25 variations and modifications of the invention and the principles disclosed herein are possible and are within the scope of the invention. Accordingly, the scope of protection is not limited by the description set out above, but is only limited by the claims which follow, that scope 30 including all equivalents of the subject matter of the claims.

 The present application is divided from British patent application no. 9516253.3.

CLAIMS

1. A cutting structure of a drill bit for cutting kerfs in formation material when the bit is rotated about its axis, said cutting structure comprising:
 - 5 a plurality of blades;
 - a set of spaced cutter elements mounted on the bit at substantially the same radial position relative to the bit axis such that each of said cutter elements in said set cuts in substantially the same kerf as the other cutter elements in said set when the bit is rotated about its axis; and,
 - 10 wherein each of said cutter elements of said set is mounted at the leading edge of a different one of said blades and at least one of said cutter elements in said set is mounted with a backrake angle that differs from the backrake angle of other elements in said set.

2. A cutting structure according to claim 16, wherein a first cutter element in said set is mounted such that its cutting profile is more exposed to the formation material than the cutting profile of a second of said elements in said set.

- 25 3. A cutting structure according to claim 2, wherein said first cutter elements are mounted with a more aggressive backrake angle than said second cutter elements.

4. A cutting structure according to claim 2, wherein said first cutter elements are mounted with a less aggressive backrake angle than said second cutter elements.

- 30 5. A cutting structure according to any of claims 1 to 4, wherein said set includes a first plurality of cutter elements mounted at a first backrake angle and a second plurality of cutter elements mounted at a second backrake angle that differs from said first backrake angle; and
- 35

wherein said cutter elements having said first backrake angle and said cutter elements having said second backrake angle are angularly spaced apart on the bit in alternating fashion.

5

6. A cutting structure according to any of claims 1 to 5, wherein said cutter elements in said set have cutting profiles that differ in shape.

10

7. A cutting structure according to claim 1, wherein a first cutter element has a more aggressive backrake angle than the backrake angle of a second cutter element in said set, and wherein the cutting profile of said first cutter element is pointed.

15

8. A cutting structure according to claim 1, wherein said cutter element set comprises a first cutter element mounted at a first backrake angle, a second cutter element mounted at a second backrake angle that differs from said first backrake angle, and a third cutter element mounted at a third backrake angle that differs from said first and second backrake angles.

20

9. A cutting structure according to claim 8, wherein said third cutter element is mounted at an exposure height that differs from the exposure height of said first and second cutter elements in said set.

25

10. A cutting structure according to claim 1, wherein said set of cutter elements comprises at least three cutter elements mounted at the leading edge of different blades at generally common radial positions relative to the bit axis and having cutting faces of unequal diameters, and wherein said cutter elements are mounted so that in rotated profile, said cutter element having the smallest cutting face is the most exposed to the formation material and said

30

35

cutter element having the largest cutting face is the least exposed to the formation material.

11. A fixed cutter drill bit for drilling through
5 formation material when said bit is rotated about its axis, said drill bit comprising:

10 a bit body including a bit face having at least one pair of radially disposed blades, each blade pair including a first blade and a second blade angularly spaced from said first blade, said blades having leading edges for cutting formation material when the bit is rotated;

15 cutter elements disposed in rows on said blades, each of said rows including cutter elements radially spaced from each other relative to the bit axis, said cutter elements in said rows having cutting faces for cutting formation material and an element axis that is normal to said bit face;

20 wherein said cutter elements in said rows are arranged in sets, each of said sets comprising a first cutter element on said first blade and a second cutter element on said second blade having element axes at generally common radial positions relative to the bit axis, said first and second cutter elements being mounted on the leading edge of their respective blades; and,

25 wherein said first cutter element is mounted at a first backrake angle and said second cutter element is mounted at a second backrake angle that is different from said first backrake angle.

30 12. A drill bit according to claim 11, wherein said first cutter elements are mounted so as to be more exposed to the formation material than said second cutter elements.

35 13. A drill bit according to claim 12, wherein said first cutter elements are mounted with a more aggressive backrake angle than said second cutter elements.

14. A drill bit according to claim 11, wherein said cutter elements in a set include cutting faces of relatively smaller and larger diameters, and wherein said cutter elements having said cutting faces of smaller diameter are
5 mounted so as to be more exposed to the formation material than said cutter elements having said cutting faces of larger diameter.

15. A drill bit according to claim 1, further comprising a
10 third blade on said bit body and a third row of cutter elements mounted on said third blade; wherein said third row of cutter elements includes a third cutter element having an axis at a generally common radial position as said first and second cutter elements; and wherein said
15 third cutter element is mounted on the leading edge of said third blade at a third backrake angle that is different from said first and second backrake angles.

16. A drill bit according to claim 1, wherein a given one
20 of said rows comprises a first plurality of said first cutter elements and a second plurality of said second cutter elements, and wherein said cutter elements are mounted in said given row in a repetitive pattern of first and second cutter elements.



Application No: GB 9721963.8
Claims searched: 1-16

Examiner: Jason Clee
Date of search: 7 January 1998

**Patents Act 1977
Search Report under Section 17**

Databases searched:

UK Patent Office collections, including GB, EP, WO & US patent specifications, in:

UK Cl (Ed.O): E1F: FFP, FGA, FGC

Int Cl (Ed.6): E21B

Other: Online: WPI

Documents considered to be relevant:

Category	Identity of document and relevant passage	Relevant to claims
A	US 5,531,281 A (Camco Drilling Group Ltd)	-
A	US 5,244,039 A (Camco Drilling Group Ltd)	-

X	Document indicating lack of novelty or inventive step	A	Document indicating technological background and/or state of the art.
Y	Document indicating lack of inventive step if combined with one or more other documents of same category.	P	Document published on or after the declared priority date but before the filing date of this invention.
&	Member of the same patent family	E	Patent document published on or after, but with priority date earlier than, the filing date of this application.