



US00D793948S

(12) **United States Design Patent**
Nunez et al.

(10) **Patent No.:** **US D793,948 S**

(45) **Date of Patent:** **** Aug. 8, 2017**

(54) **VEHICLE ORGANIZER**

(71) Applicants: **Moises E. Nunez**, Bronx, NY (US);
Isabel Sanchez De Nunez, Bronx, NY (US)

(72) Inventors: **Moises E. Nunez**, Bronx, NY (US);
Isabel Sanchez De Nunez, Bronx, NY (US)

(**) Term: **15 Years**

(21) Appl. No.: **29/565,012**

(22) Filed: **May 17, 2016**

(51) **LOC (10) Cl.** **12-16**

(52) **U.S. Cl.**
USPC **D12/415**

(58) **Field of Classification Search**
USPC D12/400, 414, 415, 416, 417, 418, 419,
D12/420, 421, 422, 424, 425, 426, 190,
D12/192, 195, 191, 106, 345, 96, 99;
D19/77, 78, 90, 92, 75, 91
CPC B60K 35/00; B60R 7/04; B60R 7/08
See application file for complete search history.

(56) **References Cited**

U.S. PATENT DOCUMENTS

D249,671 S *	9/1978	VanderWaal	D12/416
D255,310 S *	6/1980	Spencer	D7/553.5
D299,186 S *	1/1989	Sills	D12/425
D299,287 S *	1/1989	Gertler	D12/419
D338,780 S *	8/1993	Rance	D12/416

D346,402 S *	4/1994	Hassel	D19/75
D355,217 S *	2/1995	Luna	D19/78
D362,685 S *	9/1995	Perkitny	D19/75
D382,534 S *	8/1997	Green	D12/406
D430,090 S *	8/2000	Walterscheid	D12/195
D434,720 S *	12/2000	Haack	D12/419
D525,308 S *	7/2006	Lara	D19/92
D548,156 S *	8/2007	Elwell	D12/195

* cited by examiner

Primary Examiner — Karen S Acker

Assistant Examiner — Jerry Hsu

(74) *Attorney, Agent, or Firm* — Dunlap Bennett & Ludwig PLLC

(57) **CLAIM**

The ornamental design for a vehicle organizer, as shown and described.

DESCRIPTION

FIG. 1 is a front perspective view vehicle organizer; FIG. 2 is a left side elevation view thereof; FIG. 3 is a right side elevation view thereof; FIG. 4 is a front elevation view vehicle organizer, the rear elevation view being a mirror image thereof; FIG. 5 is a top plan view thereof; FIG. 6 is a bottom plan view thereof; FIG. 7 is a cross-sectional view taken on line 7-7 of FIG. 5; and, FIG. 8 is a cross-sectional view taken on line 8-8 of FIG. 5. The broken lines shown in the drawings illustrate portions of the vehicle organizer that form no part of the claimed design.

1 Claim, 3 Drawing Sheets

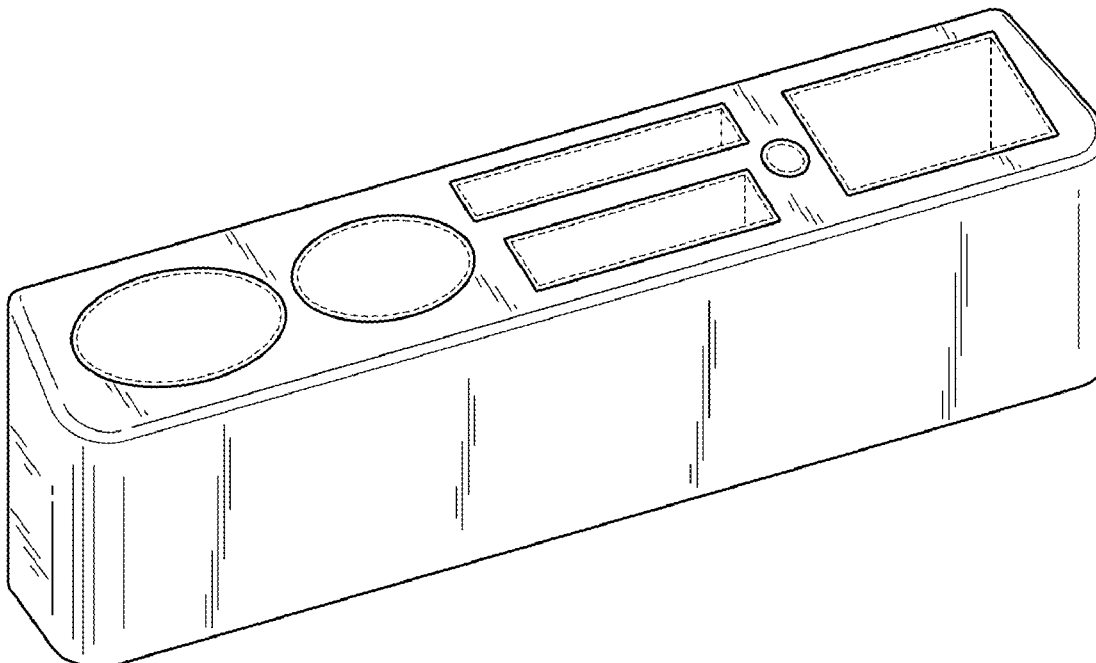

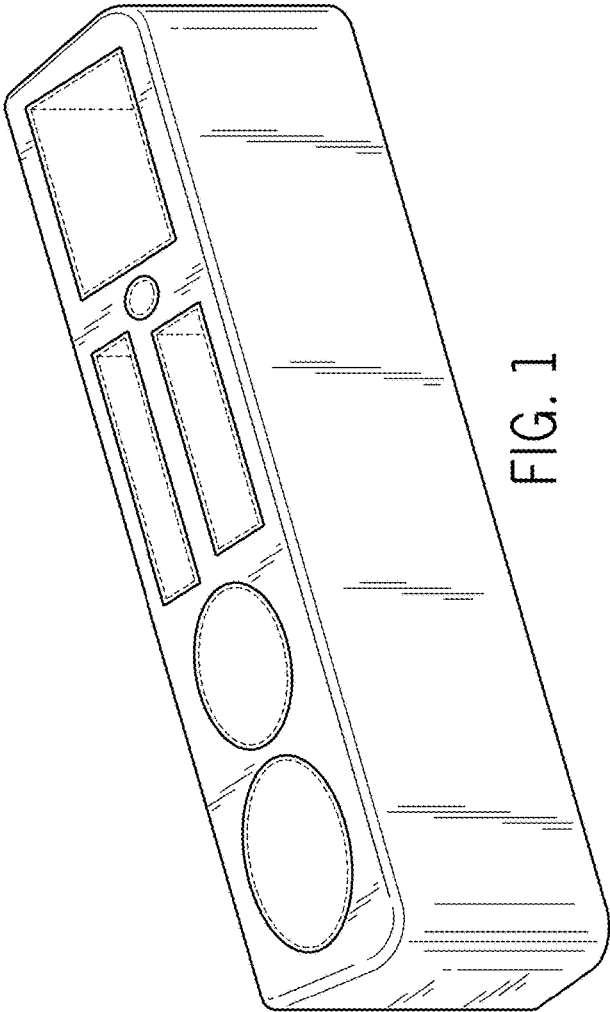

FIG. 1

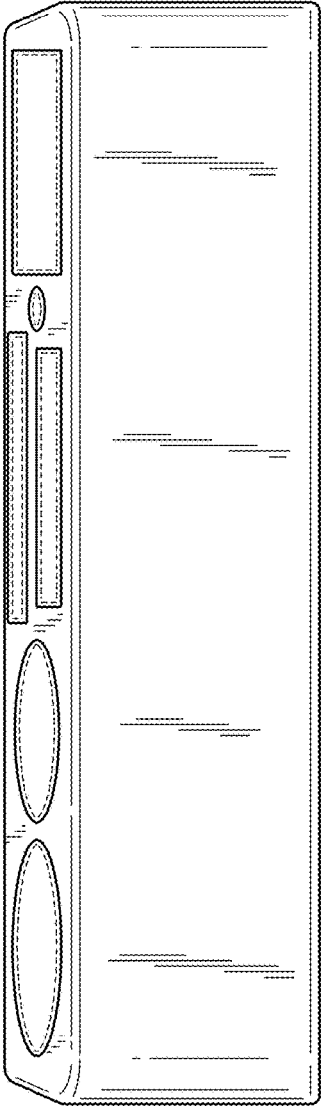

FIG. 2

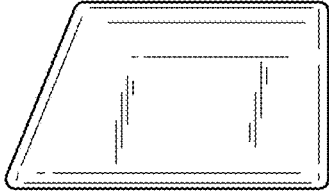

FIG. 4

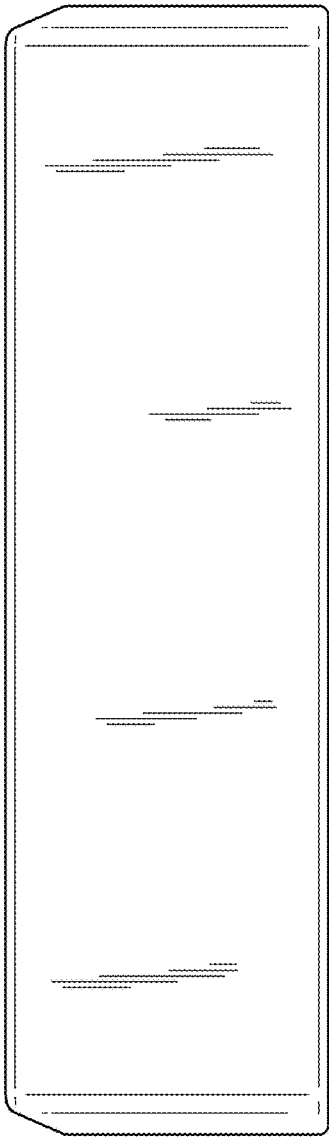

FIG. 3

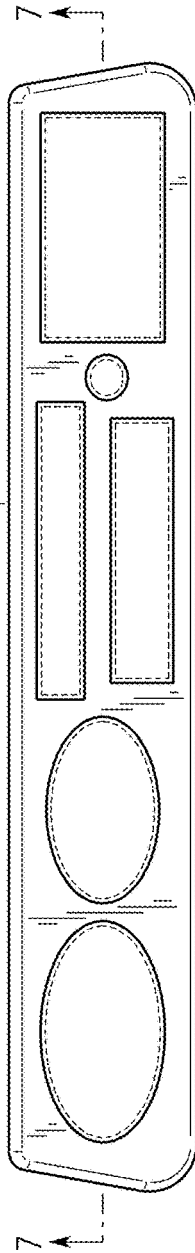

FIG. 5

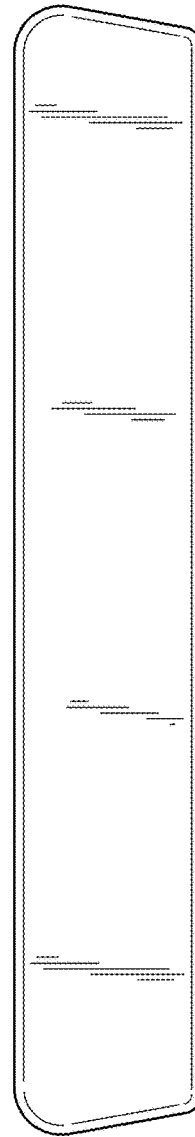

FIG. 6

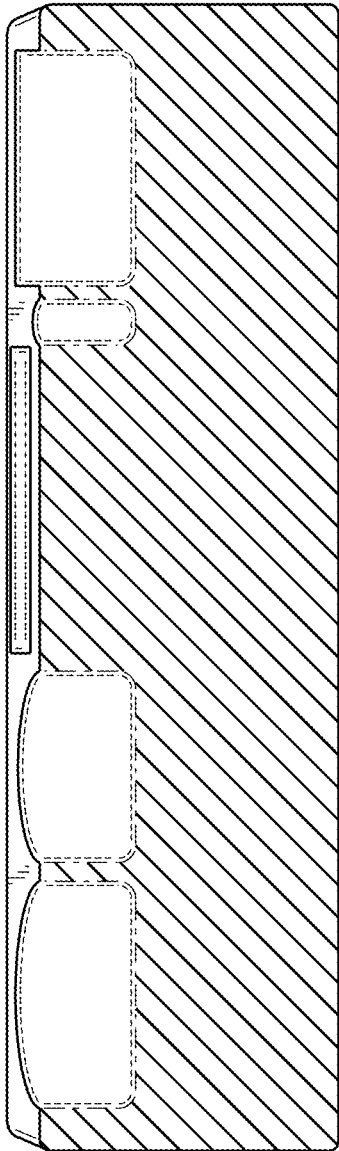

FIG. 7

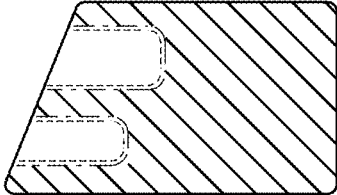

FIG. 8