

(12) **UK Patent Application** (19) **GB** (11) **2569258** (13) **A**

(43) Date of Reproduction by UK Office **12.06.2019**

(21) Application No: **1904729.9**
 (22) Date of Filing: **27.09.2017**
 Date Lodged: **04.04.2019**
 (30) Priority Data:
 (31) **2016192720** (32) **30.09.2016** (33) **JP**
 (86) International Application Data:
PCT/JP2017/036049 Ja 27.09.2017
 (87) International Publication Data:
WO2018/062570 Ja 05.04.2018

(51) INT CL:
G03G 15/08 (2006.01) G03G 21/16 (2006.01)
 (56) Documents Cited:
EP 2645177 A1 EP 1533664 A1
EP 0736819 A1 WO 2006/093361 A1
CA 002173294 A CN 101080677 A
CN 001619431 A JP 2009175759 A
JP 2005173568 A JP 2005107392 A
JP 2001005272 A US 5548384 A
US 20090129813 A1 US 20080013988 A1
US 20050135841 A1
KR 1020050048530
KR 1020070106749
 (58) Field of Search:
 INT CL **G03G**

(71) Applicant(s):
Canon Kabushiki Kaisha
30-2 Shimomaruko 3-Chome, Ohta-ku,
146-8501 Tokyo, Japan
 (72) Inventor(s):
Takashi Kimura
Hisayoshi Kojima
Yosuke Kashiide
 (74) Agent and/or Address for Service:
Canon Europe Limited
European Intellectual Property Group, 3 The Square,
Stockley Park, Uxbridge, Middlesex, UB11 1ET,
United Kingdom

(54) Title of the Invention: **Toner cartridge and toner supply mechanism**
 Abstract Title: **Toner cartridge and toner supply mechanism**

(57) The purpose of the present invention is to develop the conventional configuration of a toner cartridge. A toner cartridge comprises a container and an opening and closing member. The container comprises a housing part for housing toner, and a discharge port. The opening and closing member comprises a closing part for closing the discharge port, and a blocking force receiving part. The opening and closing member is configured to move with respect to the container between a closing position at which the closing part is caused to close the discharge port and an opening position at which the closing part is caused to open the discharge port. The opening and closing member has a front end on the downstream side of the opening and closing member and a back end on the upstream side thereof in a closing direction in which the opening and closing member moves when closing the discharge port, and is disposed in a range exceeding 180 degrees around the container between the front end and the back end when the toner cartridge is viewed along the longitudinal direction of the container. When the toner cartridge is detached from a receiving device, the blocking force receiving part receives, from a blocking force giving part of the receiving device, force for moving the opening and closing member from the opening position to the closing position.

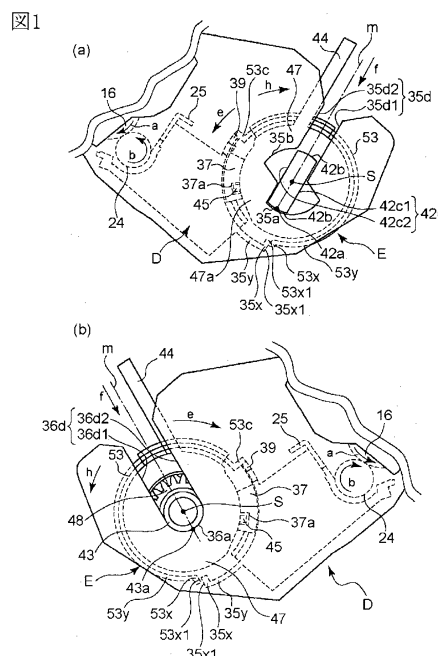

GB 2569258 A

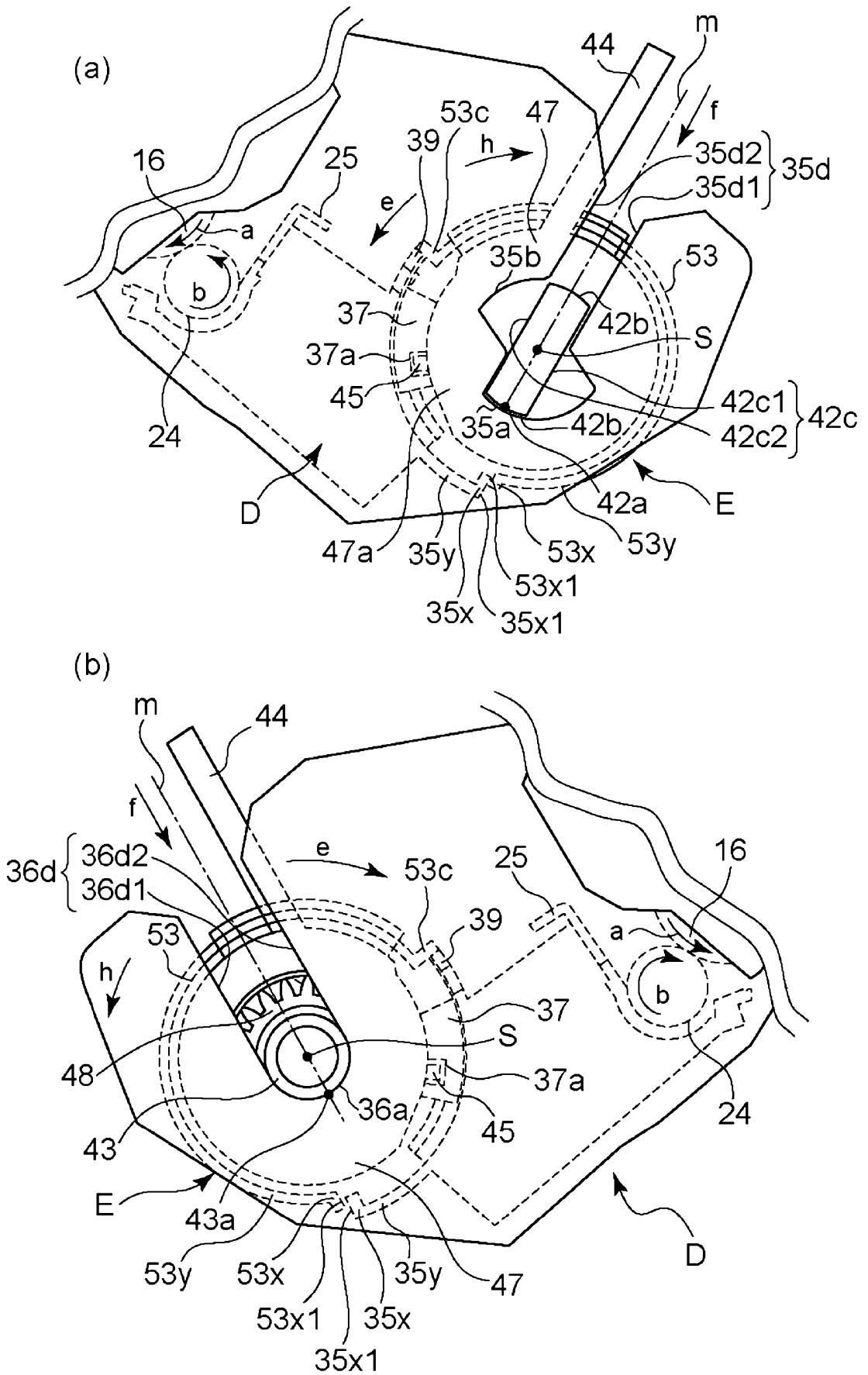

Fig. 1

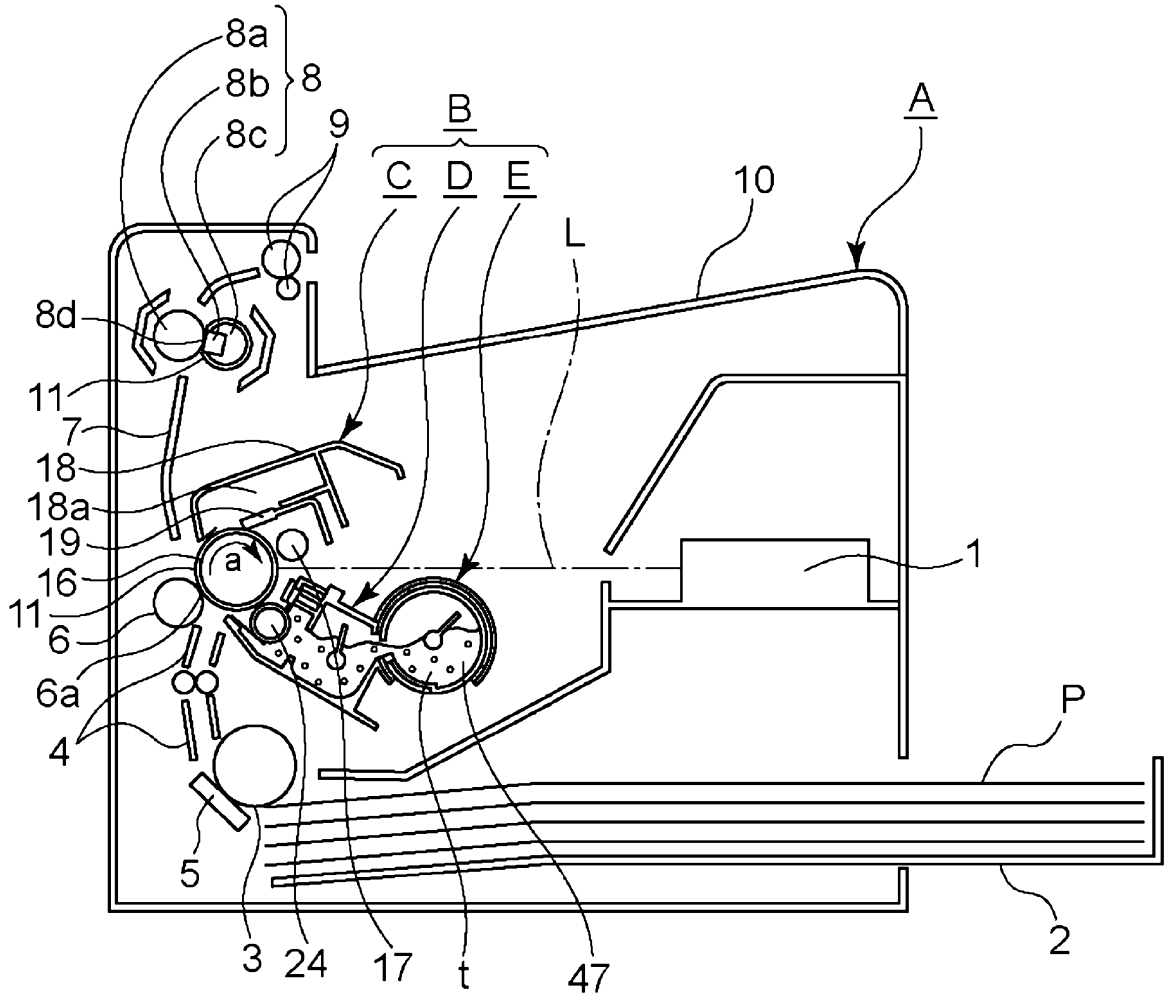

Fig. 2

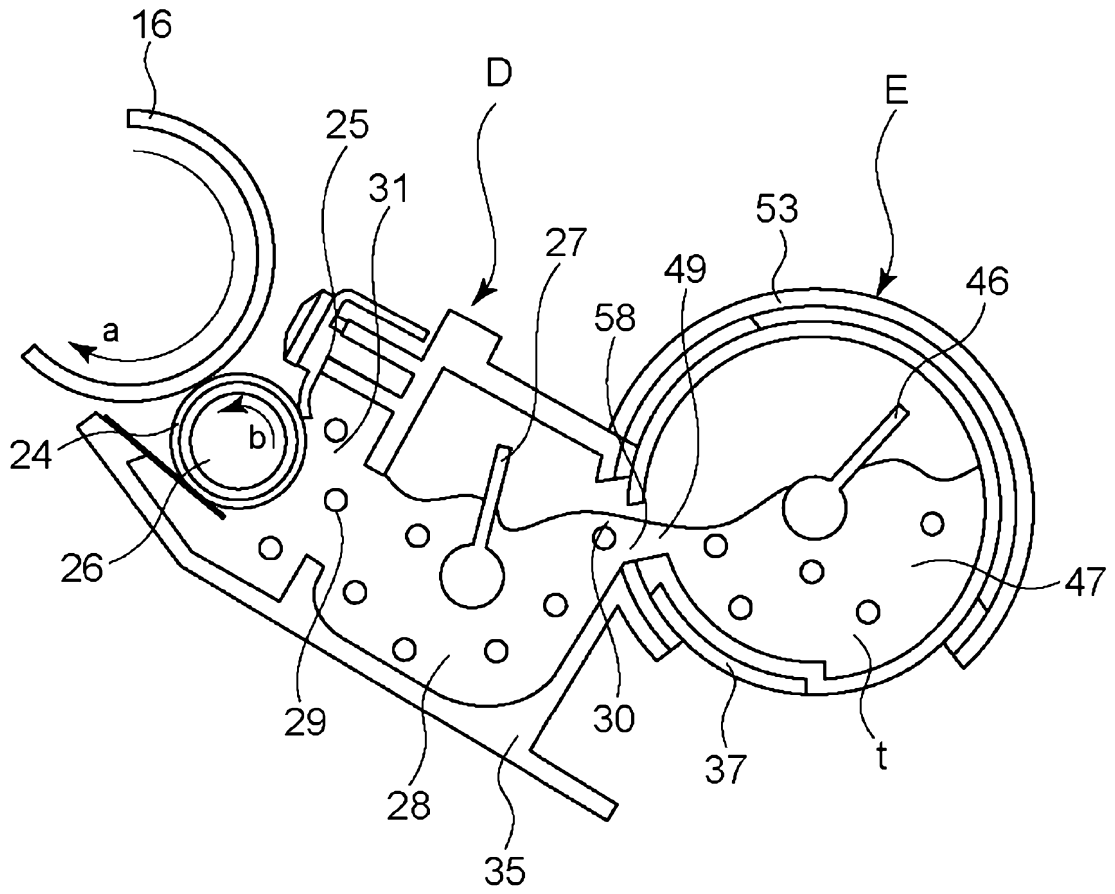
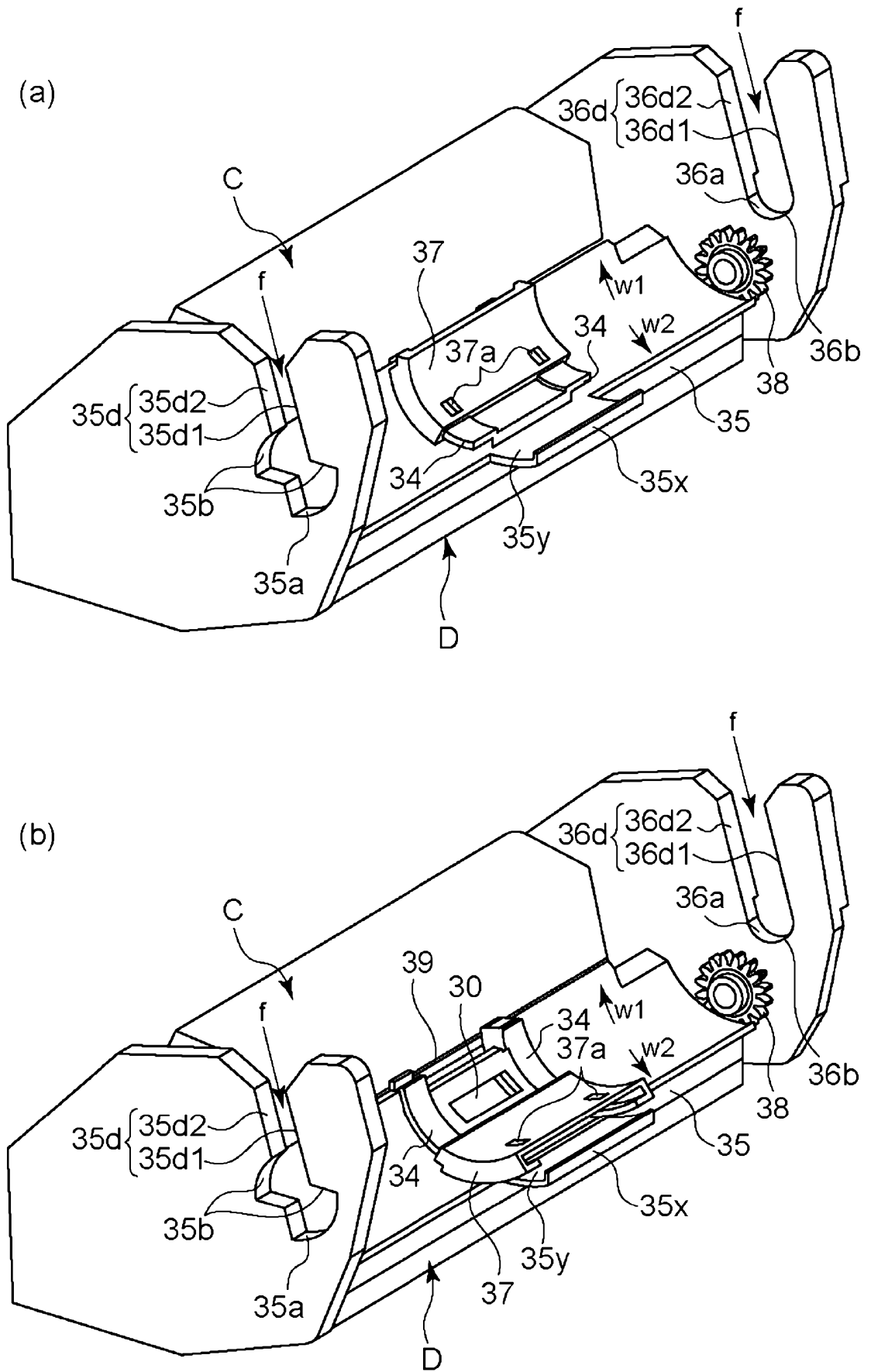

Fig. 3



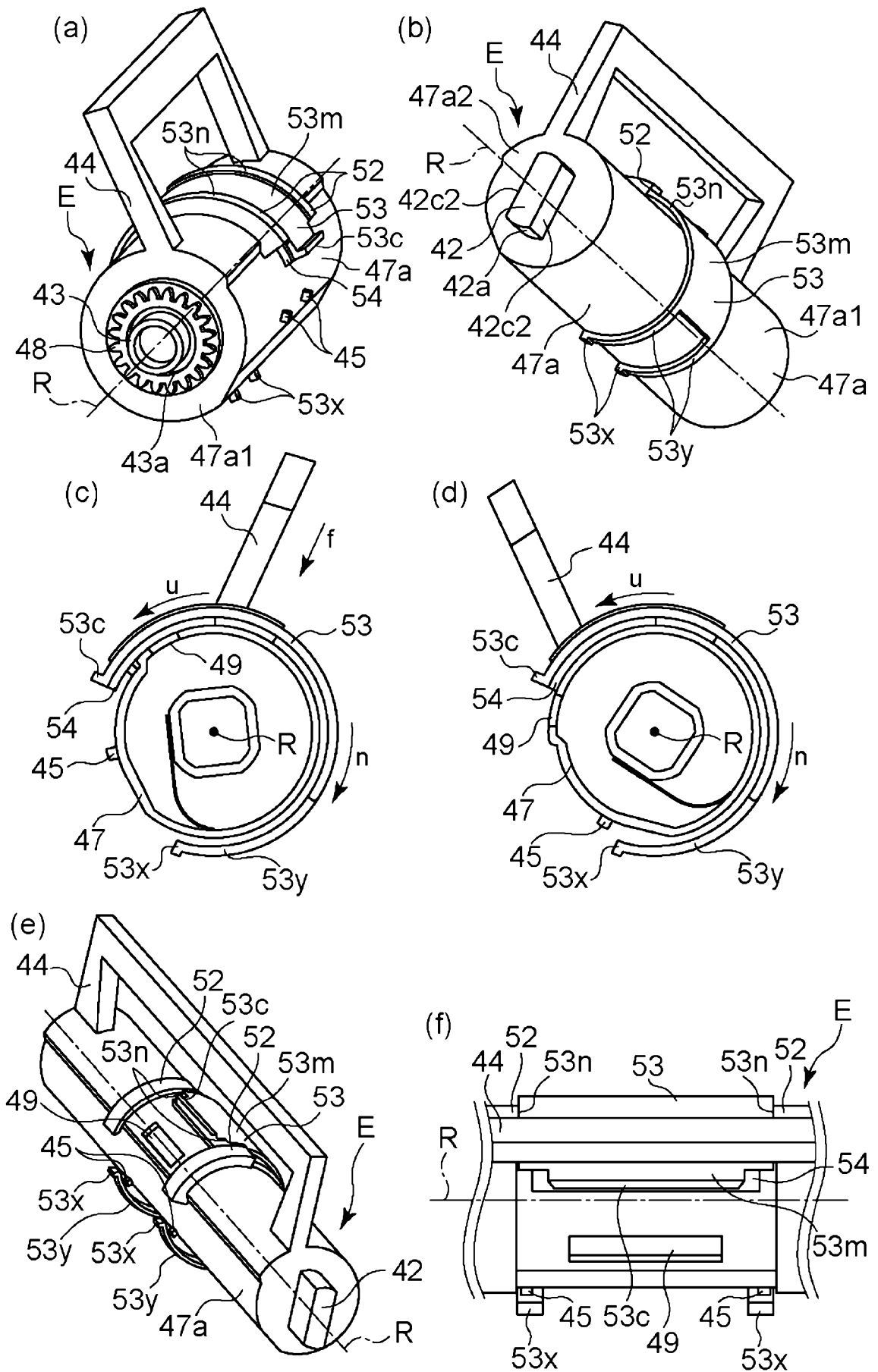

Fig. 5

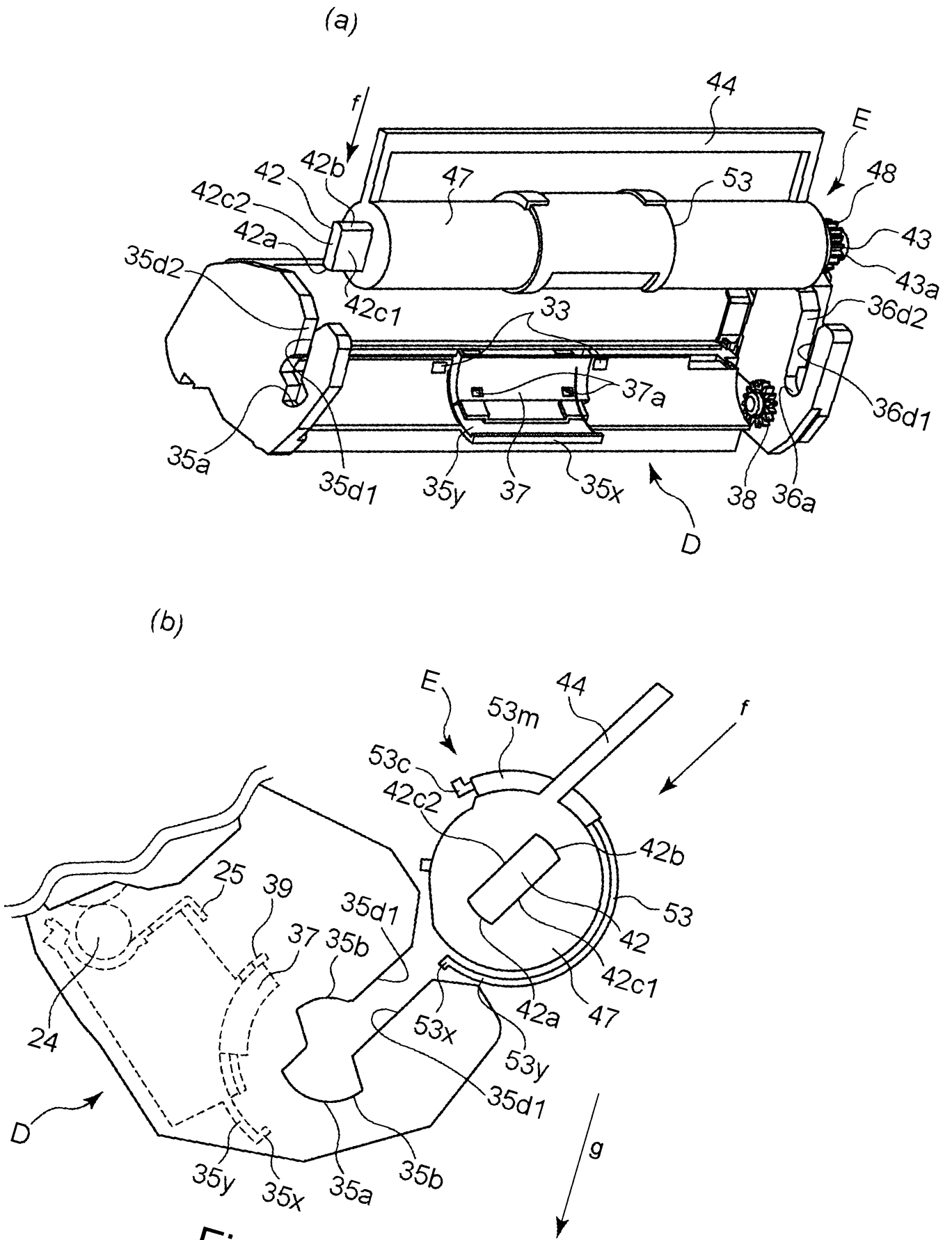

Fig. 6

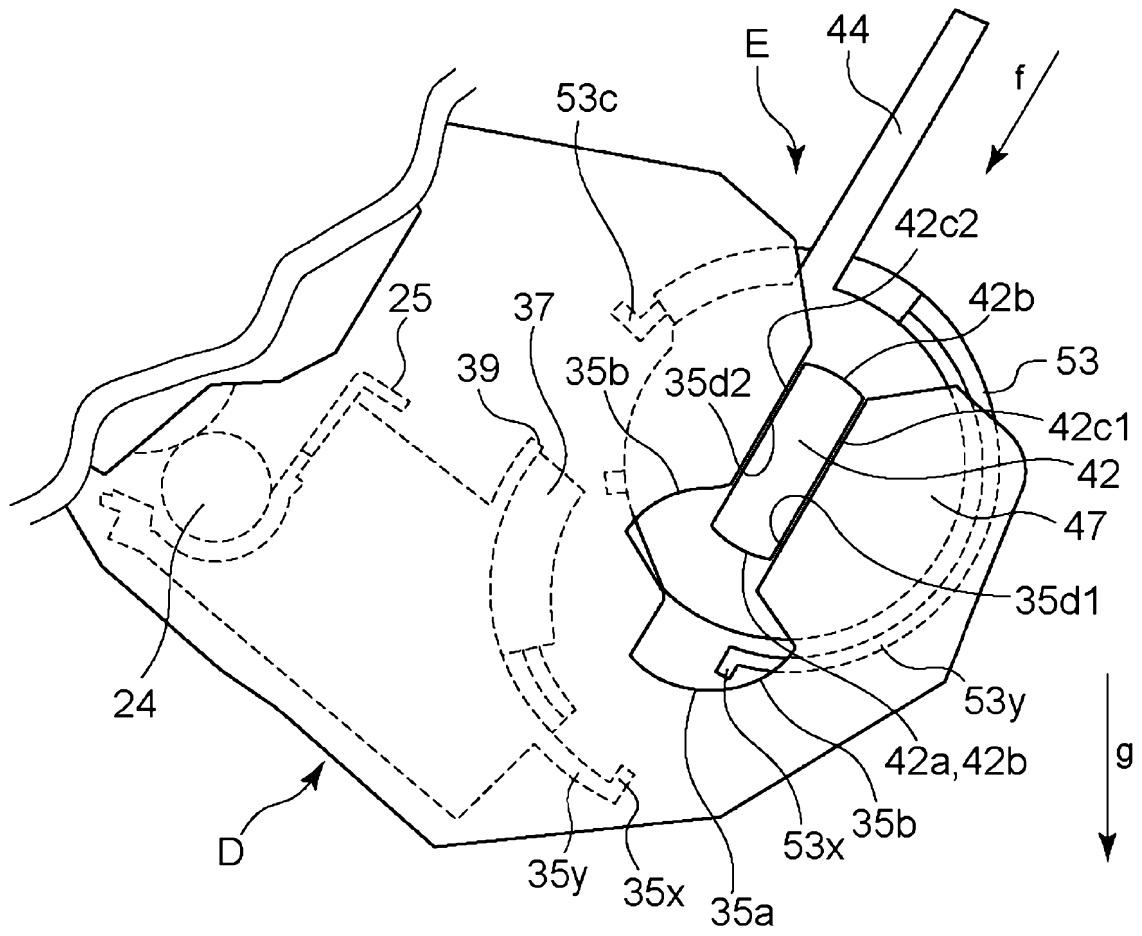
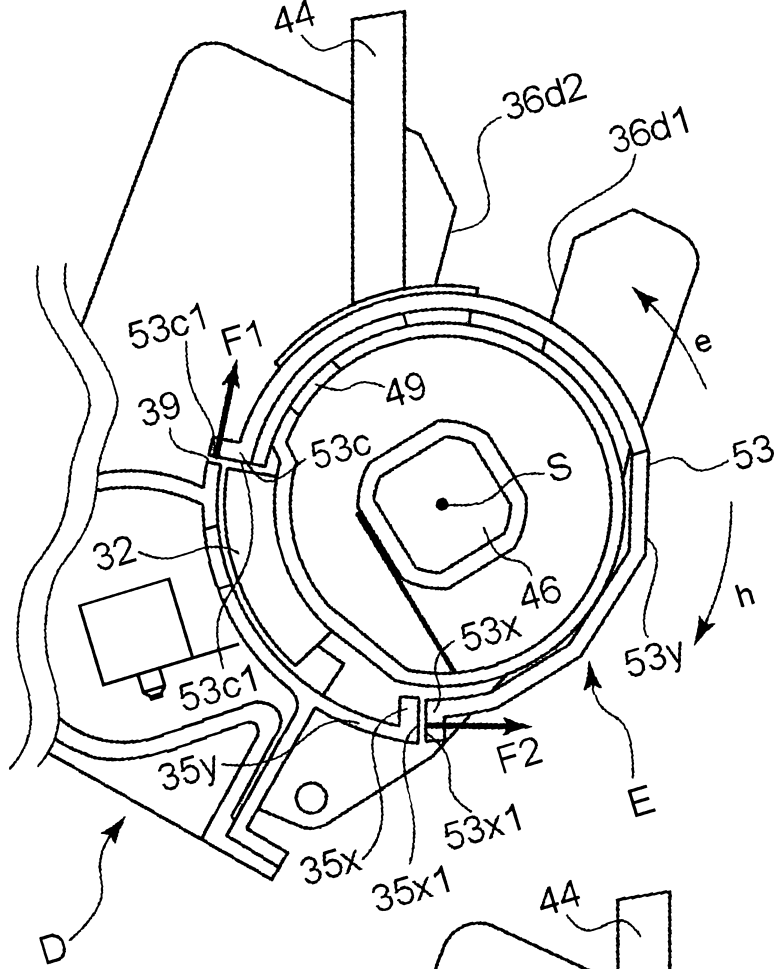

Fig. 7

(a)



(b)

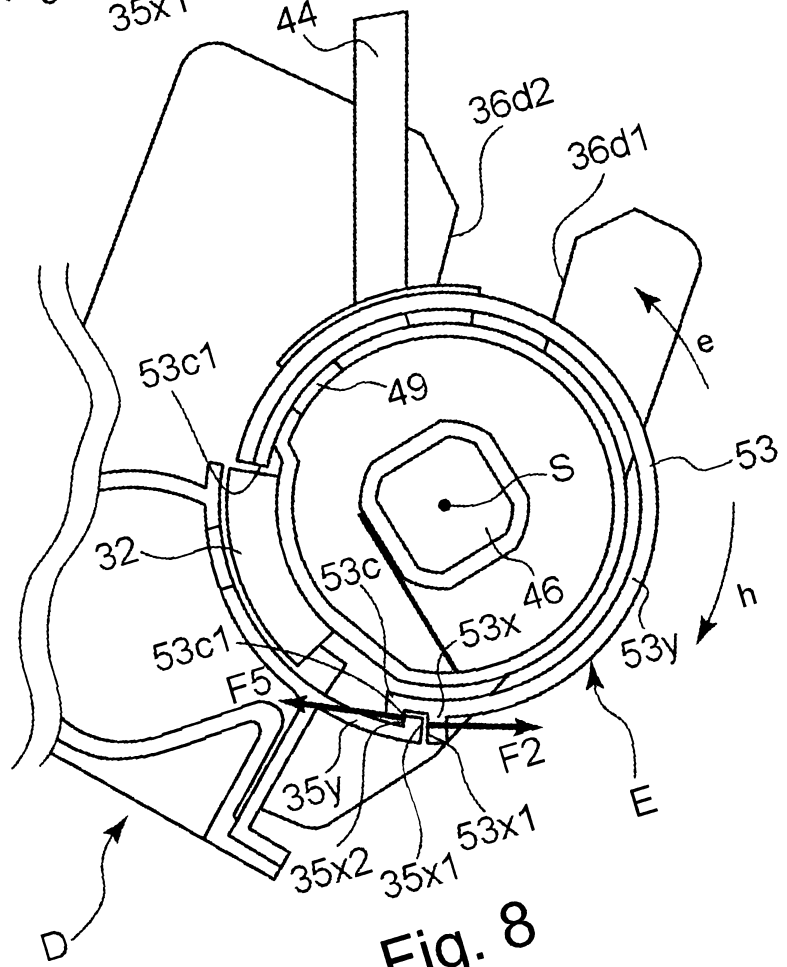

Fig. 8

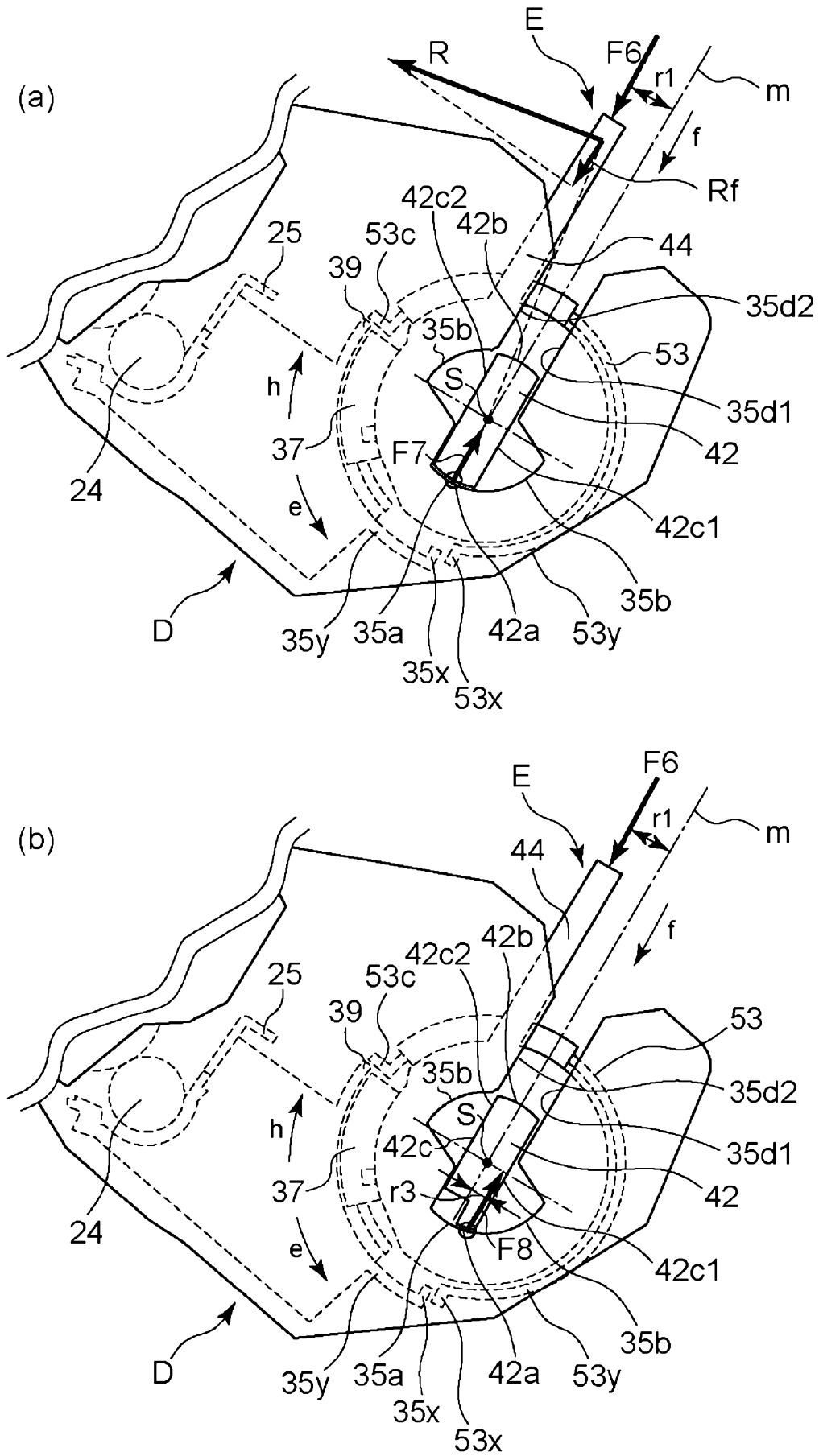

Fig. 9

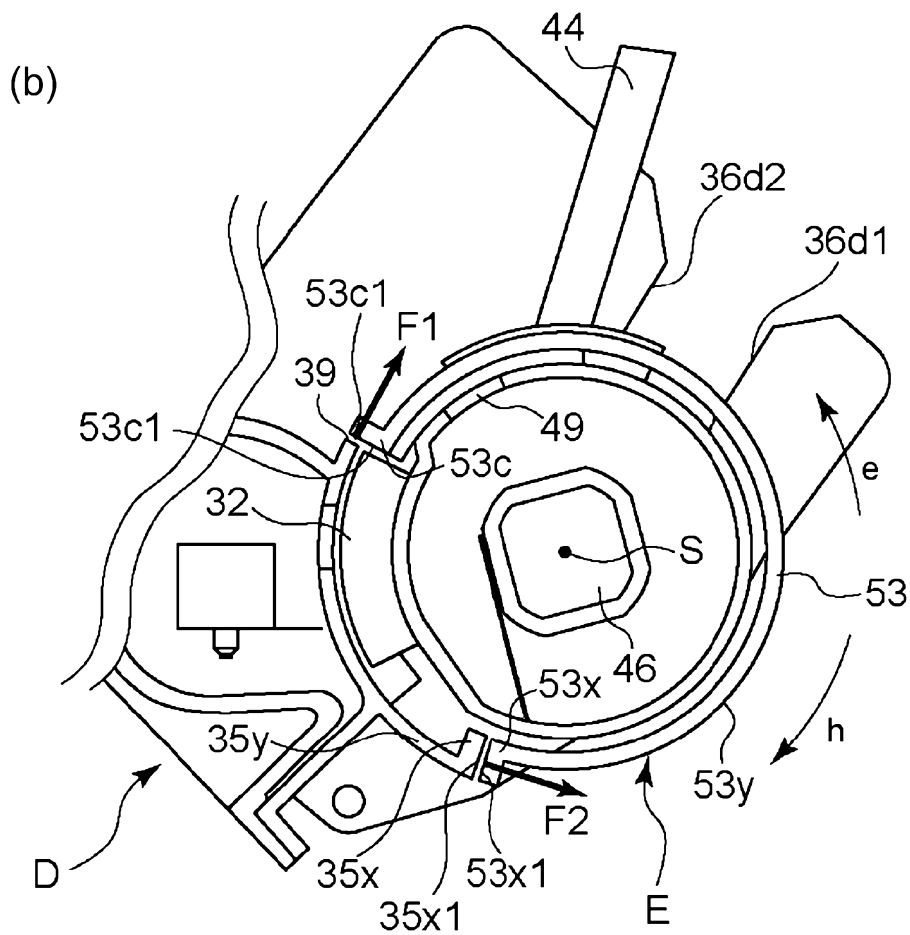
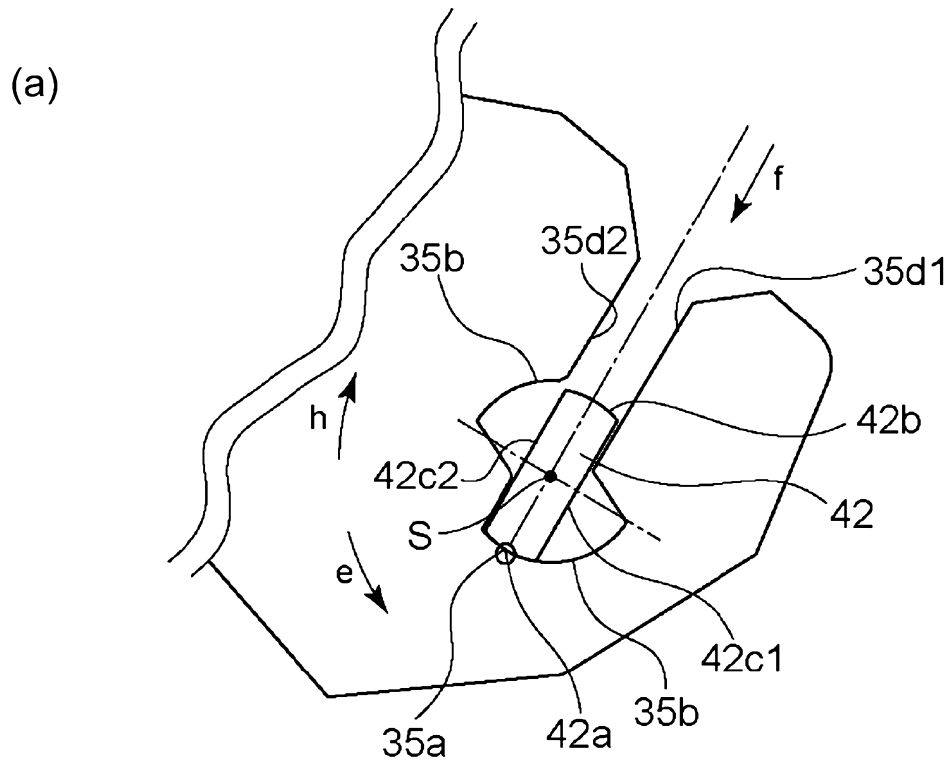

Fig. 10

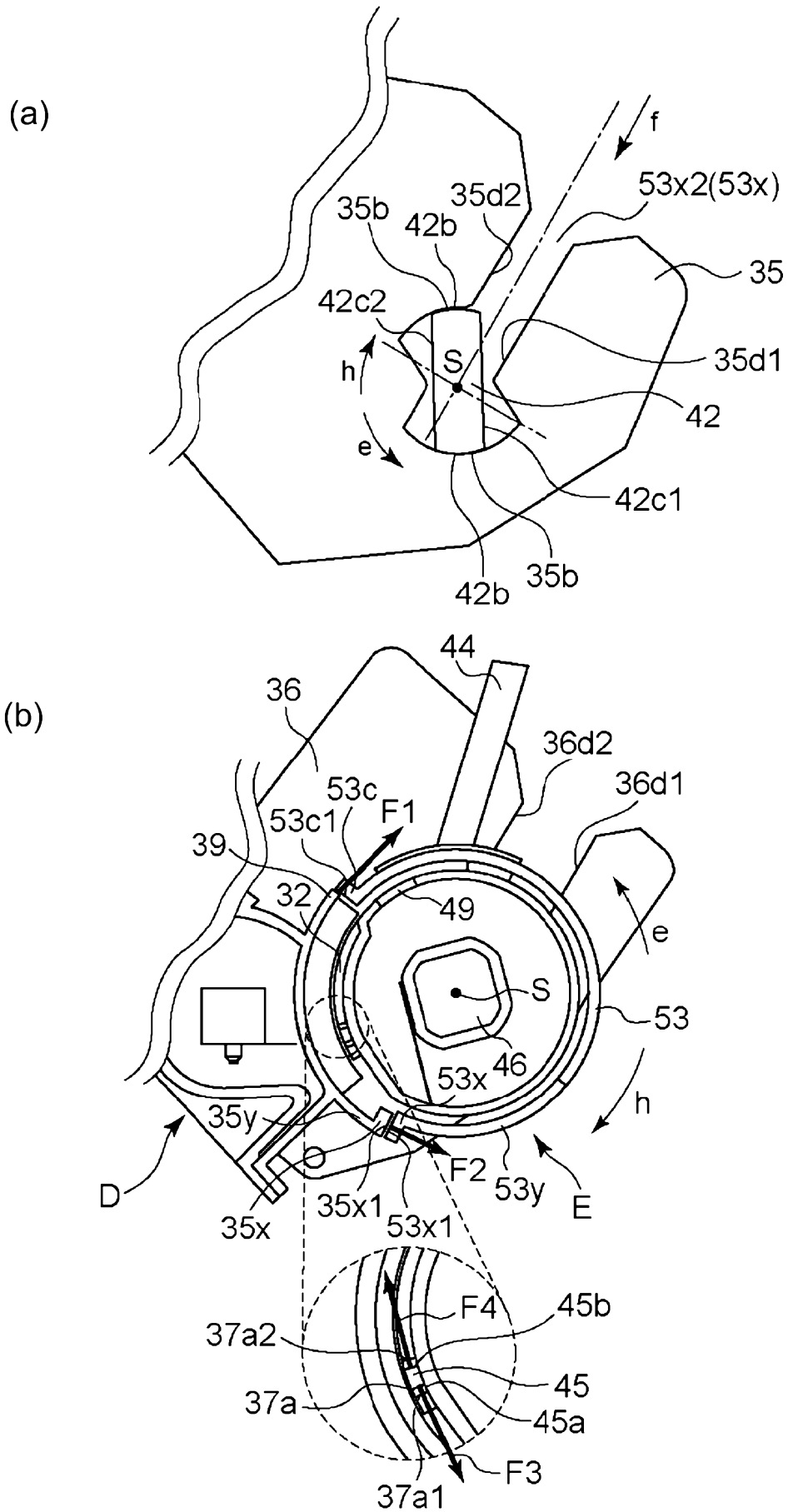

Fig. 11

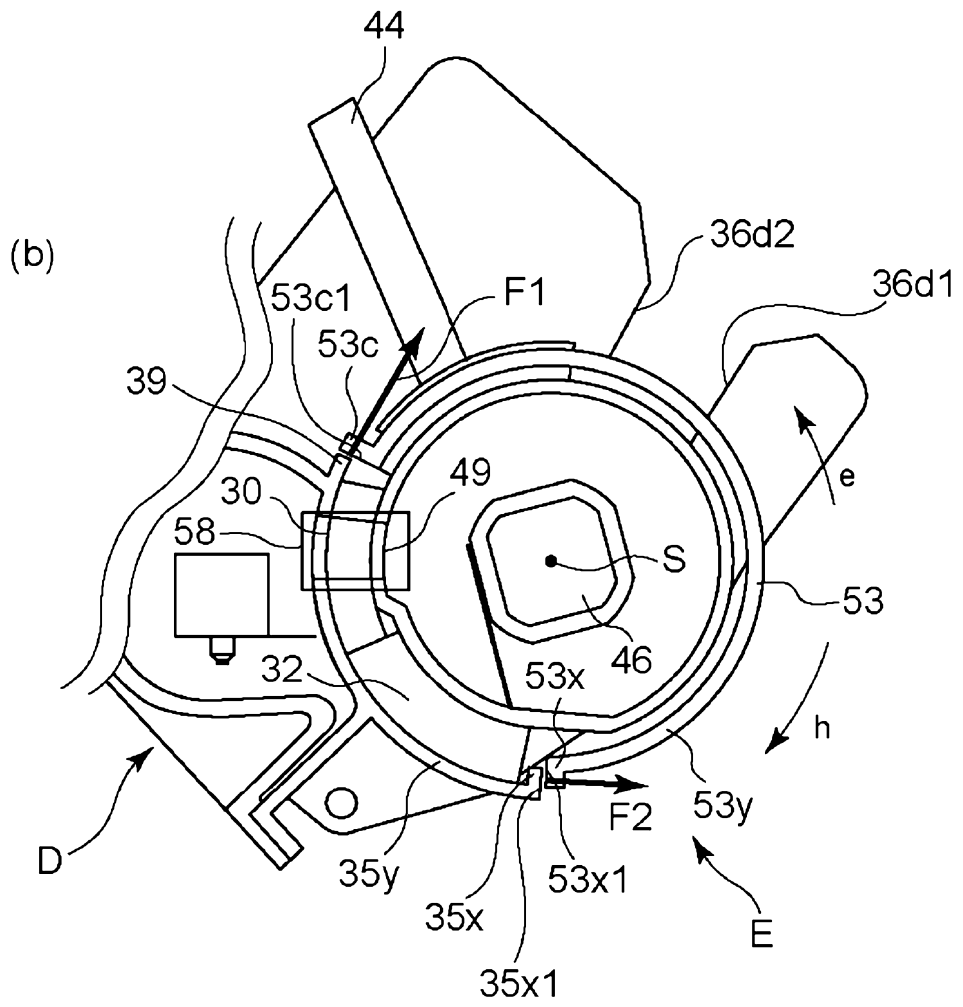
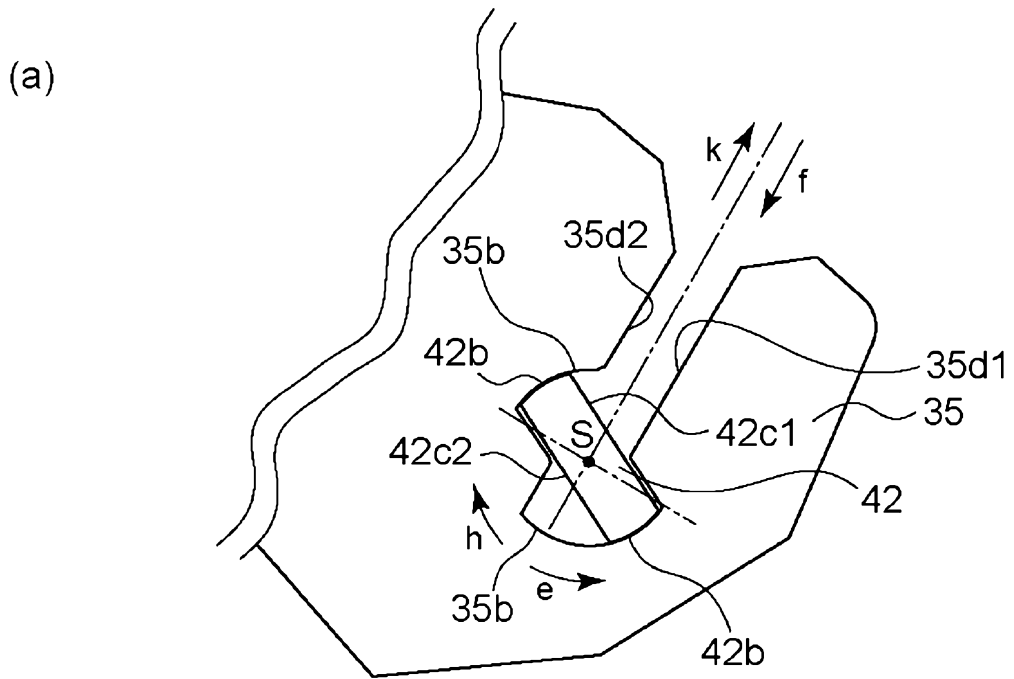

Fig. 12

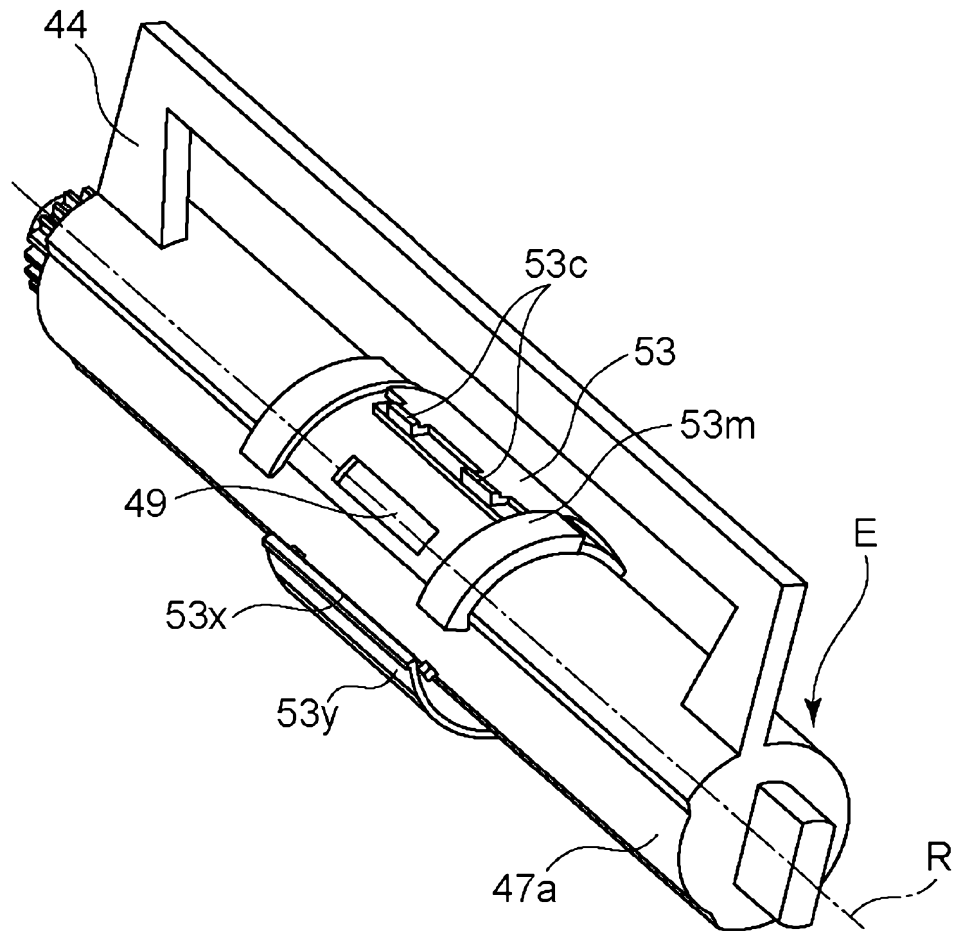
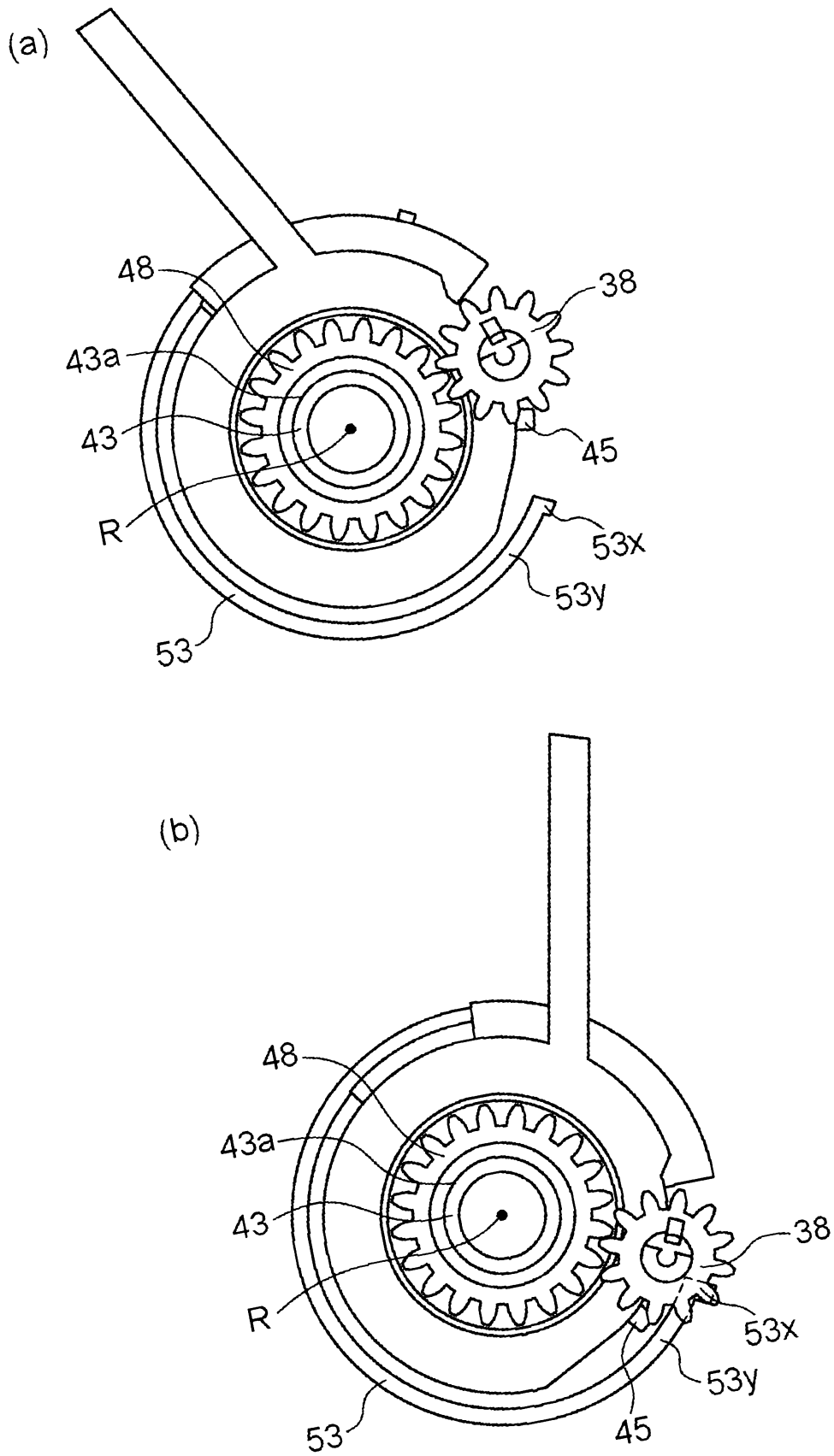

Fig. 13



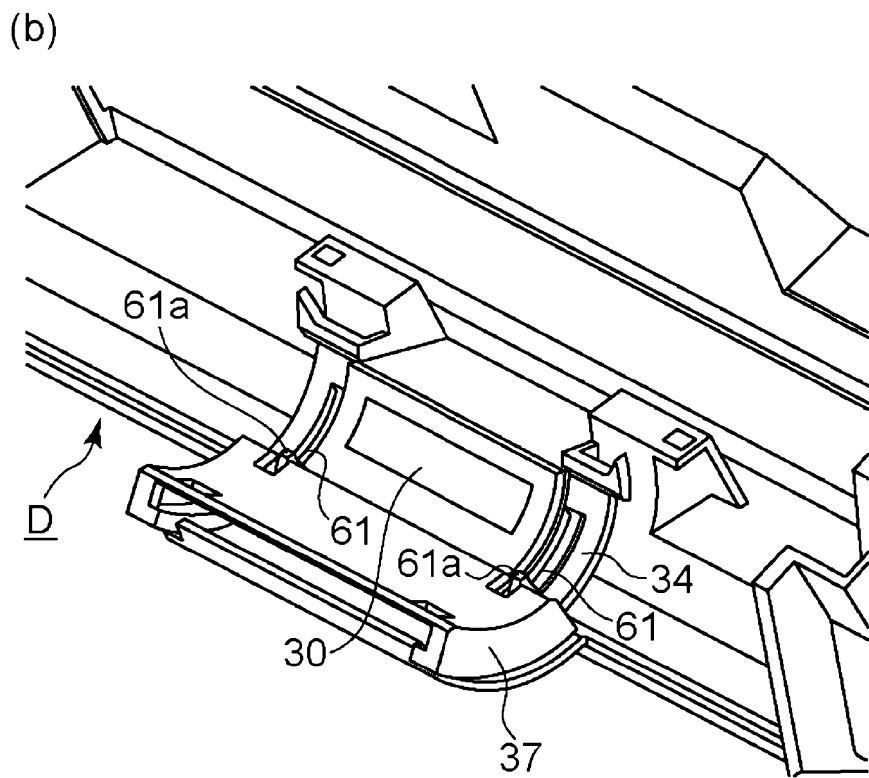
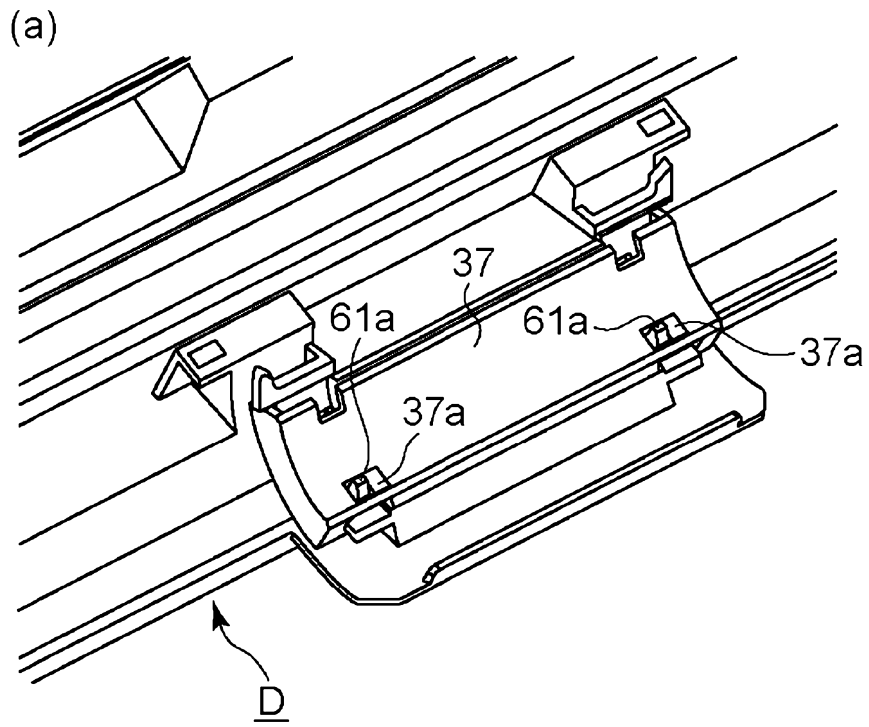

Fig. 15

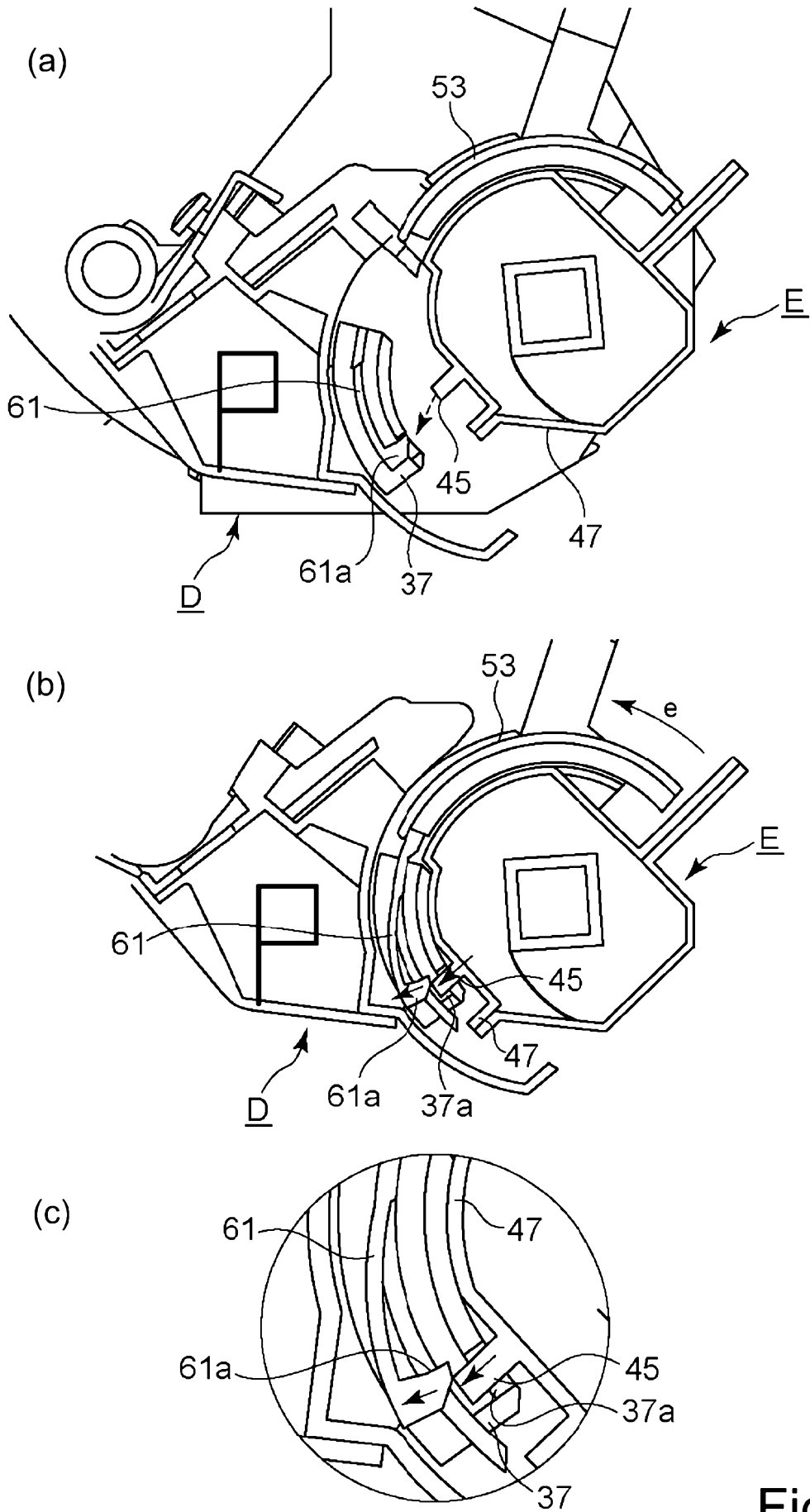

Fig. 16

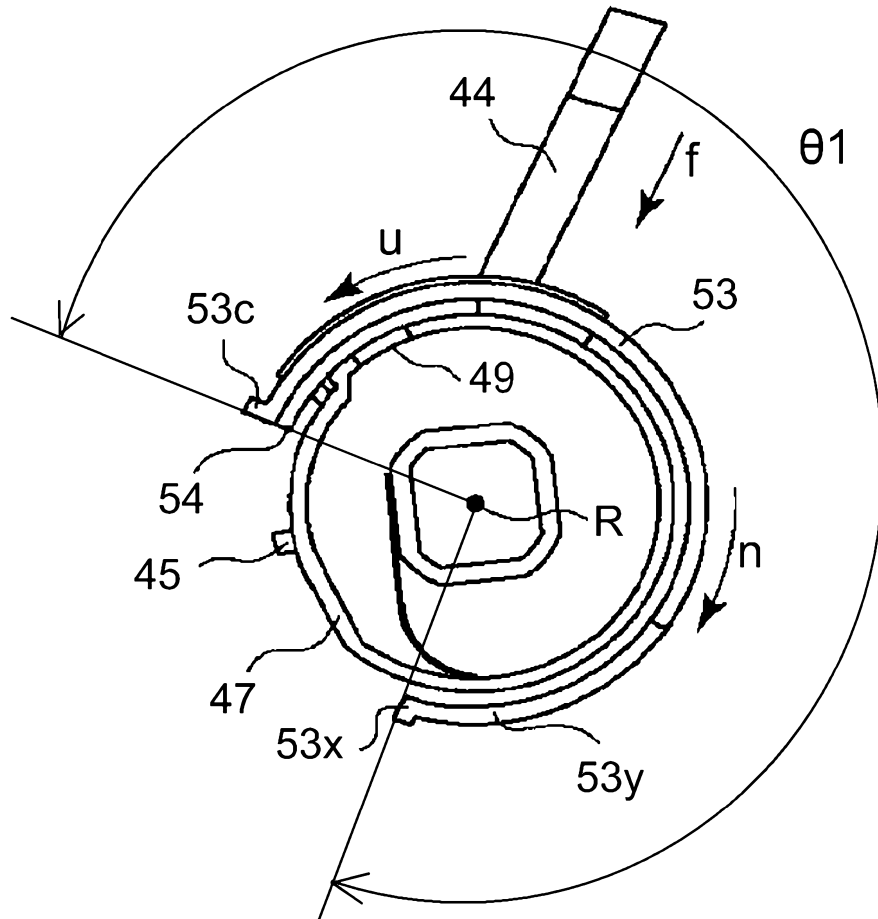

Fig. 17

DESCRIPTION

[TITLE OF INVENTION] TONER CARTRIDGE AND TONER
SUPPLYING MECHANISM

5

[TECHNICAL FIELD]

[0001] The present invention relates to a toner cartridge and a toner supplying mechanism for forming an electrophotographic image.

10

[BACKGROUND ART]

[0002] In an electrophotographic image forming apparatus, there has been known a structure in which elements such as a photosensitive drum and a developing roller as rotatable members contributable to image formation are integrated into a cartridge which is dismountable from a main assembly of an image forming apparatus main assembly (hereinafter, apparatus main assembly).

15

[0003] As one of the structures in which a cartridge is dismountably provided in such an image forming apparatus, there is also known a structure in which a toner cartridge containing toner (developer) to be consumed with image forming operation can be exchanged separately from the photosensitive drum and developing roller.

20

[0004] With such a structure, toner (developer) contained in the toner cartridge is supplied to a developing device including a developing roller and the like through a discharge port. In addition, in order to prevent the toner from leaking to the outside through the discharge port, an opening/closing member such as a shutter for opening and closing the discharge opening is provided.

25

[0005] For example, Japanese Laid-open Patent Application No. 7 - 199623 discloses a structure in which when a cylindrical toner cartridge (developer

supply container) is mounted in the image forming apparatus main assembly, the shutter is opened by rotating the toner cartridge.

[SUMMARY OF THE INVENTION]

5 [Problems to be Solved by Invention]

[0006] The object of the present invention is to develop the aforementioned prior art.

[Means for Solving the Problem]

[0007] A representative structure according to the present application is a
10 toner cartridge detachably mountable to a receiving apparatus, said receiving apparatus including a toner receiving opening, a closing force applying portion, said toner cartridge comprising (1) a container including (1 - 1) an accommodating portion for accommodating toner, and (1 - 2) a discharge opening for discharging the toner from said accommodating portion; (2) an open/close
15 member including (2 - 1) for closing said discharge opening, and (2 - 2) a closing force receiving portion, said open/close member and being movable relative to said container between a closing position for causing said closing portion to close said discharge opening and an opening position for causing said closing portion to open said discharge opening, wherein said open/close member including a
20 leading end portion and a trailing end portion which are on downstream and upstream sides of said open/close member with respect to a closing direction in which said open/close member moves to close said discharge opening, respectively, and wherein said open/close member extends from the leading end portion to the trailing end portion in a range exceeding 180 degrees of a
25 circumference of said container, as said toner cartridge is seen in the longitudinal direction of said container, wherein said closing force receiving portion is configured to receive a force for moving said open/close member from the

opening position to the closing position when said toner cartridge is dismounted from said receiving apparatus.

[Effect of the invention]

[0008] The above-mentioned conventional technique can be developed.

5

[BRIEF DESCRIPTION OF THE DRAWINGS]

[0009] Figure 1 is a side view of a toner cartridge according to an embodiment.

[0010] Figure 2 is a schematic sectional view illustrating a schematic structure of the image forming apparatus according to the embodiment.

10 **[0011]** Figure 3 is a schematic side sectional view of a state in which the toner cartridge is mounted on the developing unit.

[0012] Figure 4 is a schematic perspective view of the developing unit according to the embodiment.

15 **[0013]** Figure 5 is a schematic view of the toner cartridge according to the embodiment.

[0014] Figure 6 is a schematic illustration of a developing unit and a toner cartridge before mounting (insertion).

[0015] Figure 7 is a schematic illustration of the developing unit and the toner cartridge during mounting (insertion).

20 **[0016]** Figure 8 is a side sectional view illustrating a modified example of the structure of the extending portion and the abutting portion of the toner cartridge.

[0017] Figure 9 is a schematic side view illustrating a force relationship acting on the toner cartridge.

25 **[0018]** Figure 10 is a schematic illustration showing a state in which an abutting portion abuts to an abutted portion.

[0019] Figure 11 is a schematic illustration when a container frame is rotated and the toner cartridge is positioned.

[0020] Figure 12 is a schematic illustration when each shutter moves to the open position and each toner storing portion is communicated.

[0021] Figure 13 is a perspective view illustrating a modified example of the structure of the abutting portion of the toner cartridge.

5 **[0022]** Figure 14 is a side view of a structure in which a toner cartridge is provided with a drive transmission portion engaged with a second drive transmission portion.

[0023] Figure 15 is a view illustrating a modified example of the developing unit.

10 **[0024]** Figure 16 is a view illustrating a modified example of the developing unit.

[0025] Figure 17 is an illustration of an arrangement relationship of the second shutters.

15 **[DESCRIPTION OF THE EMBODIMENTS]**

[0026] An image forming apparatus for forming an electrophotographic image, a toner image forming portion and a toner cartridge will be described in conjunction with the accompanying drawings. Here, an image forming apparatus forms an image on a recording material by using, for example, an
20 electrophotographic image forming process. For example, it includes an electrophotographic copying machine, an electrophotographic printer (e.g. an LED printer, a laser beam printer and so on), an electrophotographic facsimile machine, and so on).

[0027] Here, in the following embodiments, a monochromatic image forming
25 apparatus provided with one toner image forming portion is exemplified.

However, the number of toner image forming portions provided in the image forming apparatus is not limited to one. For example, the image forming

apparatus may include a plurality of toner image forming portions to form a color image.

[0028] Similarly, in each structure disclosed in the embodiment, materials, arrangements, dimensions, other numerical values, and so on are not limited to
5 examples of disclosure, unless limited specifically. In addition, unless otherwise specified, "above" means upward in the direction of gravity when the image forming apparatus is installed.

<Embodiment 1>

10 **[0029]** In this embodiment, a structure that contributes to improvement of usability will be described in detail. More specifically, this embodiment relates to improvement of operation feeling when the user mounts the toner cartridge to the developing unit.

15 **[0030]** First, the structure of the entire image forming apparatus will be described, and then the developing unit and the toner cartridge will be described in detail. Here, the operation of mounting the toner cartridge to the developing unit is referred to as mounting operation, and the operation of removing the toner cartridge from the developing unit is called a dismounting operation.

20 **[0031]** In addition, the position at which a projection, a hole, and so on are engaged with each other is referred to as the engagement position, and the position at which the engagement is released is referred to as the non-engagement position (disengagement position).

[Electrophotographic Image Forming Apparatus]

25 **[0032]** Figure 2 is a side sectional view illustrating the structure of the image forming apparatus A according to this embodiment. The image forming apparatus A shown in Figure 2 receives image information from an external

device such as a personal computer which is communicatably connected therewith. And, in accordance with the received image information, the image forming apparatus A forms an image (toner image) by a developer (toner) on a recording material P (for example, recording sheet, OHP sheet, cloth, and so on) by an electrophotographic image forming process.

[0033] In the image forming apparatus A, the toner image forming portion (toner image forming unit) B is mountable to the apparatus main assembly. The toner image forming portion (toner image forming unit) B of this embodiment includes a drum unit C, a developing unit (developing device) D, and a toner cartridge E. The toner cartridge E can be mounted to and dismounted from the developing unit D. That is, the developing unit D includes a mounting portion for mounting the toner cartridge E, and is a receiving device (receiving device) for receiving the toner cartridge E.

[0034] Here, the toner image forming portion (toner image forming unit) B can be regarded as a unit including the photosensitive drum and elements acting on the photosensitive drum.

[0035] The drum unit C and the developing unit D are integrated into one cartridge, which can be dismountably mounted to the main assembly of the image forming apparatus. A cartridge in which the drum unit C and the developing unit D are integrated is sometimes called a process cartridge in particular. That is, the toner cartridge E is mounted to and dismounted from the developing unit D of the process cartridge. In this case, the entire process cartridge can also be regarded as is receiving apparatus.

[0036] In addition, with the toner cartridge E mounted on the developing unit D, the process cartridge is mountable to and dismountable from the apparatus main assembly. That is, the drum unit C, the developing unit D, and the toner cartridge E are mountable to and dismountable from the apparatus main assembly

in an integrated state. Therefore, a toner image forming unit (toner image forming unit) B including all of the drum unit C, the developing unit D, and the toner cartridge E may be referred to as a process cartridge.

[0037] Here, the drum unit C, the developing unit D, and the toner cartridge E
5 may be in the early formed into cartridges in some cases. In this case, the drum unit C may be referred to as a drum cartridge, and the developing unit D may be referred to as a developer cartridge. In addition, in some cases, the photosensitive drum (or the drum unit including the photosensitive drum) is fixed to the main assembly of the apparatus, and only the developing unit (developing
10 cartridge) D and the toner cartridge E are mountable and dismountable.

[0038] In addition, the photosensitive drum and/or the developing unit may be fixed to the apparatus main assembly and only the toner cartridge E may be dismountably mounted to the apparatus main assembly. In this case, the image forming apparatus itself can be regarded as a receiving apparatus for the toner
15 cartridge E.

[0039] In addition, the components including the receiving apparatus (developing unit D) and the toner cartridge E may be referred to as a toner supply mechanism (toner supply unit, toner supply device) or the like. In the toner supply mechanism, the toner is supplied (replenished) from the toner cartridge E
20 to the receiving apparatus.

[0040] Here, in this example, a photosensitive drum as an image bearing member has a structure in which a flange or the like is integrally mounted to a cylinder including a photosensitive layer.

[0041] Mounting and dismounting of each cartridge is carried out by the user
25 (operator, user). In addition, the main assembly of the apparatus (main assembly of the image forming apparatus) refers to the structure portion excluding each cartridge (drum unit C, developing unit D, and toner cartridge E)

from the image forming apparatus A.

[0042] The drum unit C is a unit in which a photosensitive drum (image bearing member) 16, a charging roller 17, a cleaning blade 19 and the like are integrally unitized, and in this embodiment, it is a cartridge (drum cartridge) mountable to and dismountable from the apparatus main assembly. In addition, the developing unit D is a unit in which a developing roller (developer carrying member) 24 and the like are integrated as a unit, and in this embodiment, it is a portion of a cartridge mountable to a dismountable from the main assembly of the apparatus. The toner cartridge E is a cartridge in which a toner container (developer container, container) 47 and the like for containing the toner t as a developer are integrally formed as a cartridge.

[0043] The photosensitive drum 16 rotates in the direction of the arrow a shown in Figure 2. The surface of the rotating photosensitive drum 16 is uniformly charged by charging roller 17 as charging means. The laser beam L corresponding to image information is irradiated from the laser scanner (exposure means) 1 onto the photosensitive drum 16, so that an electrostatic latent image corresponding to the image information is formed on the photosensitive drum 16. And, the toner t carried on the developing roller 24 develops the electrostatic latent image. By this, a toner image is formed on the photosensitive drum 16.

[0044] Here, referring to Figure 3, a development process in the toner image forming portion B will be explained. A frame 35 of the developing unit D as the receiving apparatus rotatably supports the developing roller 24. The developing roller 24 receives a driving force from a power source such as a motor (not shown) provided in the main assembly of the apparatus and is rotationally driven in the forward direction (the direction of an arrow b in the Figure) with respect to the photosensitive drum 16.

[0045] The toner t in the developing chamber 31 is carried on the peripheral

surface of the developing roller 24 with its layer thickness regulated by the developing blade 25. When layer thickness is regulated, electric charge is applied to the toner by triboelectrical charging. And, the charged toner develops the electrostatic latent image on the photosensitive drum 16.

5 **[0046]** In the developing unit D, the developing chamber 31 communicates with the first toner containing portion (developer accommodating portion) 28 through the first opening portion 29. A first toner feeding means 27 which is rotationally driven by a driving source (not shown) supplies the toner t from a first toner containing portion 28 to the developing chamber 31.

10 **[0047]** In addition, a communicating portion 58 is formed by a second opening portion (containing body opening, receiving port, receiving opening) 30 and a third opening portion (container opening, discharge port, discharge opening) 49. Through this communication portion 58, the first toner containing portion (containing member accommodating chamber) 28 communicates with a second
15 toner containing portion (container accommodating chamber) 47t of the toner cartridge E.

[0048] A second toner container 47t contains toner, and therefore, it is a space provided inside the container 47. The second toner storing portion 47t is a storing portion (toner storing portion, developer storing portion) formed by the
20 frame (container frame 47a) of the container 47.

[0049] A third opening portion 49 is formed in the container frame 47a and is a discharge opening for discharging the toner from the second toner containing portion 47t to the outside of the toner container 47 (that is, the developing unit D). The toner discharged from the third opening portion 49 is received in the second
25 opening (receiving port) 30 of the developing unit D.

[0050] In the first toner containing portion 28, the toner t is supplied from the second toner containing portion 47t by a second toner feeding member 46 which

is rotated by the driving force inputted from the main assembly of the apparatus by way of the developing unit D.

[0051] Referring back to Figure 2, the description will be further made. The recording material P set in the feeding cassette 2 is separated and fed one by one
5 by the pickup roller 3 and the pressure contact member 5 pressed against the pickup roller 3. And, in synchronization with the toner image formed on the photosensitive drum, the recording material P is fed along the feeding guide 4 to the transfer roller 6 as a transfer means.

[0052] Next, the recording material P passes through the transfer nip portion
10 11 formed by the photosensitive drum 16 and the transfer roller 6 which is supplied with a constant voltage is applied. At this time, the toner image formed on the photosensitive drum 16 is transferred onto the recording material P. The recording material P on which the toner image is transferred is fed to the fixing means 8 by a feeding guide 7.

[0053] The fixing means 8 includes a driving roller 8a and a fixing roller 8c
15 incorporating a heater 8b. The recording material P is subjected to heat and pressure when passing through the nip portion 8d formed between the fixing roller 8c and the driving roller 8a. By this, the toner image transferred onto the recording material P is fixed on the recording material P. Thereafter, the
20 recording material P on which the toner image has been fixed is fed by the pair of discharge rollers 9 and is discharged to a discharge tray 10.

[0054] The cleaning blade 19 is elastically contacted to the outer peripheral
surface of the photosensitive drum 16. By this, the toner t (untransferred residual toner) remaining on the photosensitive drum 16 that has not been
25 transferred onto the recording material P is scraped off by the cleaning blade 19. The scraped toner t is stored in the removed toner containing portion (waste toner containing portion) 18a of the frame 18 to which the cleaning blade 19 is fixed.

[0055] As described in the foregoing, in the image forming apparatus of this embodiment, an image is formed on a recording material (recording material) with the developer (toner) through an electrophotographic image forming method. Naturally, it is satisfactorily to form an image on the recording material as an
5 image forming apparatus and therefore, an electrophotographic copying machine, an electrophotographic printer (a laser beam printer, a LED printer, and so on), an electrophotographic facsimile machine, an electrophotographic word processor, and the like are usable, and the form thereof is not limited.

[0056] As described in the foregoing, the toner image forming portion B
10 includes an electrophotographic photosensitive member (photosensitive member) which is an image bearing member and a process means actable on the photosensitive member. In this embodiment, the toner image forming portion can be dismountably mounted to the main assembly of the image forming apparatus as one or more cartridges.

15 **[0057]** The process means includes charging means (charging member, charging device), developing means (developing device, developing unit), cleaning means (cleaning device, cleaning member), and the like.

[0058] A developing device is a device used for developing the electrostatic latent image formed on a photosensitive member. In this embodiment, the
20 developing device (developing unit) is formed into a cartridge and can be dismounted from the image forming apparatus as a unit. On the other hand, the developing device may constitute a portion of the process cartridge.

[0059] In addition, a toner cartridge (a developer cartridge, a toner bottle, a developer bottle, a toner container, a developer container) is a cartridge
25 containing a developer (toner) used for developing the electrostatic latent image formed on the photosensitive member.

[Structure of each cartridge (each unit)]

[0060] A detailed structure of each cartridge (each unit) dismountably provided in the image forming apparatus will be described.

(Details of Neighborhood of Toner Cartridge Receiving Portion of Developing
5 Unit)

[0061] Referring to Figure 4, a detailed structure of the neighborhood of the receiving portion of the toner cartridge E of the developing unit D according to this embodiment will be described. Figure 4 is a perspective view of the neighborhood of the receiving portion (mounting portion) of the toner cartridge E
10 of the developing unit D. Part (a) of Figure 4 shows a state in which the second opening portion 30 is closed (the first shutter 37 is in the closing position). In addition, part (b) of Figure 4 illustrates a state in which the second opening portion 30 is open (the first shutter 37 is in the open position). In this example, the longitudinal direction of the developing unit D is a direction parallel to the
15 rotational axis direction of the developing roller 24 of the developing unit D. Here, in a state in which the toner cartridge E is mounted to the developing unit, the longitudinal direction of the toner cartridge E is substantially parallel to the longitudinal direction of the developing unit D.

[0062] In the developing unit D, and the toner cartridge E can be mounted (or
20 dismounted) to the frame (developing frame) 35. In the neighborhood of the receiving portion, the developing unit D has the second opening (containing body opening, receiving port) 30 and the first shutter (containing body shutter, receiving apparatus side shutter, receiving apparatus side opening/closing member) 37. In this embodiment, the second opening portion 30 is provided in
25 the central portion in the longitudinal direction of the developing unit D. However, the position of the second opening portion 30 is not limited to the central portion in the longitudinal direction as long as it faces the third opening

(container opening) 49 which will be described hereinafter.

[0063] As shown in part (a) of Figure 4, the second opening portion 30 is sealed by a first shutter 37 including a shape having a curvature along the outer peripheral surface of the toner cartridge E.

5 **[0064]** The first shutter 37 has a hole portion 37a which is engaged with a projection (a container side engaging portion, an opening/closing member moving portion, a container side projection) 45 provided in the toner cartridge E as a developer container. Two such projections 45 and two such hole portions 37 are provided. This hole portion 37a is provided outside the sealed area where
10 the first shutter 37 seals the second opening portion 30.

[0065] In addition, the end portions, in the longitudinal direction, of the first shutter 37 are engaged with a first shutter guide portions 34 provided on the respective sides, in the longitudinal direction, of the second opening portion 30 in the frame 35 of the developing unit D. By this, the first shutter is constituted to
15 be slidable (movable) along the first shutter guide portion 34 (the directions of arrows W1 and W2).

[0066] By doing so, the first shutter 37 is movable between the closing position for closing the second opening portion 30 (the receiving opening closing position, part (a) of Figure 4) and the open position (the receiving port opening
20 position, part (b) of Figure 4) for opening the second opening portion 30.

[0067] In addition, the developing unit D is provided with a toner receiving portion (closing force applying portion) 35x and a toner receiving portion 35y below the gravity direction g of the second opening portion 30 (part (b) of Figure 4) in order not to let the toner t leaking through the second opening portion 30 fall
25 from the developing unit D. The toner receiving portion 35y is a surface covered with the first shutter 37 taking the open position (part (a) of Figure 4). The toner receiving portion 35x is a projection provided at the end portion of the

toner receiving portion 35y and extends in the longitudinal direction.

In this example, the arrangement of the toner receiving portions 35x and 35y in the longitudinal direction is such that they are outward of the second opening portion 30 in the longitudinal direction and outward of the hole portion 37a in the longitudinal direction (not shown). However, the arrangement of the toner receiving portions 35x and 35y in the longitudinal direction is not limited to this example. However, from the standpoint not to let the toner t leaking through the second opening portion 30 fall from the cartridge. It is preferable to extends it to a region outside the second opening portion 30 with respect to the longitudinal direction.

[0068] Even if toner leaks from the second opening portion 30 when the first shutter 37 moves, the toner can be kept on the toner receiving portion 35y and the toner receiving portion 35x. This suppresses toner from entering the main assembly of the apparatus from the cartridge.

[0069] In addition, as shown in part (b) of Figure 4, a first sealing seal 32 for sealing the gap between the first shutter 37 and the second opening portion 30 is mounted to the frame 35 of the developing unit D so as to surround the second opening portion 30.

[0070] The developing unit D is provided at opposite longitudinal ends with insertion guide portions (receiving apparatus side guides) 35d, 36d for guiding the toner cartridge E while maintaining the attitude (mounting attitude) of the toner cartridge when mounting (inserting) the toner cartridge E into the frame 35.

[0071] In addition, the developing unit D is provided with an abutted portions 35a, 36a against which the abutting portions 42a, 43a of the toner cartridge E abut when the toner cartridge E is inserted, as will be described hereinafter.

[0072] Furthermore, the developing unit D has rotation guide portions 35b, 36b for guiding the rotation of the toner cartridge E at opposite longitudinal ends

of the frame 35 when opening and closing the first shutter 37 and the second shutter (container shutter) 53.

[0073] The insertion guide portions 35d, 36d linearly extend parallel to each other along the inserting direction f (part (a) of Figure 4) of the toner cartridge E.

5 Here, a direction opposite to the inserting direction of the toner cartridge E is sometimes referred to as a removal direction (a direction to removing the toner cartridge E from the development unit D) in some cases. In this case, the downstream side in the inserting direction can be regarded as the upstream side in the removal direction, and the insertion upstream side can be regarded as the
10 downstream side in the removal direction.

[0074] In the developing unit D, the abutted portion 35a and the rotation guide portion 35b are provided on the downstream side, in the inserting direction f, of the insertion guide portion 35d on the non-driving side at the drive side, and the abutted portion 36a and the rotation guide 36b are provided on the downstream
15 side, in the inserting direction f, of the insertion guide portion 36d.

[0075] Here, regarding the opposite end sides in the longitudinal direction of the developing portion D, the side on which a drive portion such as a gear (e.g. The first drive transmission portion 38) is disposed is hereinafter referred to as the drive side. The non-driving side of the developing unit is opposite to the
20 driving side in the longitudinal direction.

[0076] Furthermore, the first drive transmission portion 38 for transmitting the drive to the second toner feeding means 46 of the toner cartridge E which will be described hereinafter is provided at one end, in the longitudinal direction, of the frame 35 of the developing unit D.

25 **[0077]** The first drive transmission portion 38 is a gear and is connected to the drive mechanism of the image forming apparatus main assembly inside the development unit D. The first drive transmission portion 38 is a torque

transmission portion (drive force transmission portion) for transmitting the rotational force for driving the second toner feeding member 46 from the outside of the toner cartridge E.

(Detailed Description of Toner Cartridge)

5 **[0078]** Referring to Figure 5, a detailed structure of the toner cartridge E according to this embodiment will be described.

[0079] Part (a) of Figure 5 is a perspective view of the toner cartridge E as viewed from the second drive transmission portion 48 side (drive side). In addition, part (b) of Figure 5 is a perspective view in a state where the second
10 shutter 53 closes the third opening portion 49 as the toner cartridge E is viewed from the side opposite to the second drive transmission portion 48 side (non-drive side). Part (c) of Figure 5 is a sectional view of the toner cartridge E in the closed state of the third opening portion 49 as viewed from the side opposite to the side of the second drive transmission portion 48. In addition, part (d) of
15 Figure 5 is a sectional view of the toner cartridge E in the state where the third opening portion 49 is opened as viewed from the side opposite to the side of the second drive transmission portion 48. And, part (e) of Figure 5 is a perspective view of the second shutter 53 of the toner cartridge E when it is in the open position (state in which the third opening portion 49 is open). Part (f) of Figure
20 5 is an enlarged view of the neighborhood of the third opening with the third opening portion 49 in the opened state. Here, in Figure 5, the toner t is not shown.

[0080] The toner cartridge E is provided with the container 47, the second shutter (developer container shutter) 53 movable relative to the container 47, the
25 second toner feeding member 46 provided inside the container 47, the second drive transmission portion (gear) 48 mounted to the second toner feeding member 46, and the like.

[0081] The container 47 has a substantially cylindrical shape. That is, the frame (container frame) 47a constituting the body portion (main portion) of the container 47 has a substantially cylindrical shape. Here, the longitudinal direction of the toner cartridge E is the longitudinal direction of the cylindrical shape.

[0082] An insertion guided portion (guided portion, toner cartridge side guide portion) 42 projecting outward, in the longitudinal direction, of the side wall 47a2 of the container frame 47a is provided at the end portion. In the longitudinal direction, of the container 47. Similarly, at the other longitudinal end portion of the container 47, an insertion guided portion (guided portion, toner cartridge side guide portion) 43 projecting outward, in the longitudinal direction, of the side wall 47a1 of the container frame 47a is provided.

[0083] In addition, the container 47 has an operating portion 44 to be operated by a user. The operating portion 44 is a U-shaped projection integrally formed with the frame 47a. Here, the shape of the operating portion 44 is not limited to the U shape. In addition, the operating portion 44 may be formed integrally with the container frame 47a, or may be made of a member different from the frame 47a and mounted to the frame 47a. The operating portion 44 is a holding portion (grip, gripping section) for the user to grip when inserting or removing the toner cartridge E.

[0084] As shown in part (c) of Figure 5, the container frame (cylindrical portion) 47a is hollow and forms a second toner containing portion 47t in which the toner t is accommodated. A second toner feeding member 46 for feeding the toner is rotatably provided inside the second toner containing portion 47t of the container frame 47a. A second drive transmission portion 48 for receiving the power (rotational force, driving force) for rotationally driving the second toner feeding member 46 is provided at one end portion, in the longitudinal direction

(rotational axis direction), of the second toner feeding member 46 (part (a) of Figure 5). The second drive transmission portion 48 is a gear (drive input gear) which receives the driving force (rotational force) from the outside (that is, from the developing unit D as the receiving device) of the toner cartridge E.

5 **[0085]** Here, in this embodiment, the driving force is directly transmitted from the second drive transmission portion 48, which is the drive input gear, to the second toner feeding member 46. However, the driving force may be transmitted from the driving input gear to the second toner feeding member 46 via another driving transmission member (for example, one or a plurality of
10 gears). Referring to Figure 14, such a structure like this will be described hereinafter.

[0086] The container frame 47a is provided with two projections 45 provided so as to be engageable with the hole portion 37a of the first shutter 37, on the outer circumference of its cylindrical shape. The two projections 45 project in
15 substantially the same direction. In the direction of inserting the toner cartridge E into the developing unit D, the projection 45 projects toward the downstream side.

[0087] In addition, the line connecting the two projections 45 is substantially parallel to the longitudinal direction of the toner cartridge E. As shown in part
20 (f) of Figure 5, in the longitudinal direction of the container 47, the two projections 45 are arranged outside the third opening portion 49. To describe it in more detail, when the two projections 45 and the third opening portion 49 are projected onto an imaginary line parallel to the center axis R of the container frame 47a, the entire projection area of the third opening portion 49 is positioned
25 within the range sandwiched between the projection areas of the two projections (not shown).

[0088] When the second shutter 53 moves from the open position to the closed

position, the leading end portion of the second shutter 53 approaches to the two projections 45.

[0089] In addition, as shown in part (e) of Figure 5, a third opening portion 49 for discharging the toner t of the second toner containing portion 47t is provided on the peripheral surface of the container frame 47a. In this embodiment, the third opening portion 49 is provided on the outer peripheral surface of the container frame 47a at the center portion of the toner cartridge E in the longitudinal direction. However, the position of the third opening portion 49 is not limited to a specific position as long as it is a position facing the second opening portion 30.

[0090] As shown in part (c) of Figure 5, a cross-section of the second shutter 53 (a portion perpendicular to the center axis R of the container frame 47a) has a curved shape (substantially circular arc shape) extending along the outer circumference of the container frame 47a.

[0091] The surface of the container frame 47a has a curved surface shape (substantially cylindrical shape, substantially circular arc shape) at least around the third opening portion 49. The second shutter 53 can rotate (revolve) around the container frame 47a along this curved surface portion (circular arc portion) around the third opening portion 49. By this, the second shutter 53 can open and close the third opening portion 49.

[0092] More specifically, in the state in which the third opening portion 49 is opened (part (d) of Figure 5), the second shutter 53 moves relative to the container frame 47a in the direction of arrow u. Then, the third opening portion 49 changes from the open state to the closed state (part (c) in Figure 5).

[0093] In addition, the second shutter 53 includes a shutter body portion 53m (body portion, closing portion) for closing the third opening portion 49. Here, the longitudinal direction of the shutter body 53m is substantially parallel with

the longitudinal direction of the toner cartridge E.

[0094] Here, the leading end side of the second shutter 53 is on the downstream side in the direction (arrow u direction) in which the second shutter 53 moves relative to the container frame 47a when the second shutter 53 closes the third opening portion 49. The leading end of the second shutter 53 is an end portion (first abutting portion) 53c on the downstream side in the arrow u direction in a short side direction of the second shutter 53 (direction perpendicular to the longitudinal direction of the second shutter 53).

[0095] In addition, the trailing end side of the second shutter 53 is on the upstream side in the direction (arrow u direction) in which the second shutter 53 moves relative to the container frame 47a when the second shutter 53 closes the third opening portion 49. The trailing end of the second shutter 53 is the end portion (second abutting portion) 53x on the upstream side, in the arrow u direction in the short side direction, of the second shutter 53 (the direction perpendicular to the longitudinal direction of the second shutter 53).

[0096] A first abutting portion (opening force receiving portion, engaging portion) 53c projecting in the outer circumferential direction of the container frame 47a is provided at the leading end portion of the second shutter 53. In this embodiment, the first abutting portion 53c is provided at one position in the longitudinal direction center of the shutter body 53m of the second shutter 53 (part (f) of Figure 5), but it is not limited to this structure, and it may be provided at each of two places, as shown in Figure 13. In addition, the first abutting portion 53c is formed integrally with the second shutter 53, but they may be formed as separate members.

[0097] An extending portion 53y is provided on the trailing end side of the second shutter 53. And, a second abutting portion 53x (closing force receiving portion, engaging portion) projecting in the outer peripheral direction of the

container frame 47a is provided in the neighborhood of the trailing end of the second shutter 53 of the extending portion 53y. Here, in the second shutter 53, the angle from the first abutting portion 53c to the second abutting portion 53x is 180 ° or more. That is, the second shutter 53 extends from the leading end (first abutting portion 53c) to the trailing end (second abutting portion 53x) thereof and is placed in a range exceeding 180 ° around the container frame 47a.

[0098] That is, as viewing the toner cartridge E along the longitudinal direction thereof, the second shutter 53 covers half or more of the periphery of the container frame 47a. With such a structure, the second shutter 53 is difficult to be removed from the container frame 47a. It is possible to prevent the second shutter 53 from being dismounted from the container frame 47a due to erroneous operation by the user.

[0099] Referring to Figure 17, the arrangement relationship of the second shutter 53 will be described in more detail. The second shutter 53 has been described as being disposed in a range exceeding 180 ° around the container 47. Angle $\theta 1$ shown in Figure 17 is a angle around the center R of the container frame 47a from the front end 53c of the second shutter 53 to the trailing end 53x thereof. This angle $\theta 1$ is larger than 180 °. In particular, as the toner cartridge E of this embodiment is viewed along its longitudinal direction, the second shutter 53 is placed in a range of 230 ° or more around the container frame 47a. On the other hand, the area where the second shutter 53 is arranged is set at 270 ° or less. That is, the angle $\theta 1$ is not less than 230 ° and not more than 270 °. At this time, the area range in which the second shutter 53 does not exist is at least 90 ° around the container frame 47a.

[0100] Here, the center R of the container 47 as a reference of the angle $\theta 1$ is the rotation axis of the container 47. That is, the center R at which the container 47 rotates when opening and closing the second shutter 53 is the reference of the

angle $\theta 1$. In addition, the frame of the container 47 has a substantially cylindrical shape. The center R of this cylindrical shape is the reference of the angle $\theta 1$.

[0101] As shown in part (f) of Figure 5, in the longitudinal direction, a part of the second abutting portion 53x is provided more inside than the two projections 45 in the longitudinal direction. To describe it in more detail, as projecting two projections 45 and the second abutting portion 53x on an arbitrary imaginary plane parallel to the central axis R of the container frame 47a (not shown), a part of the region sandwiched by the second abutting portions 53x is located within the range of the region sandwiched by the two projection portions.

[0102] Here, the position of the second abutting portion 53x is not limited to this structure, and it suffices if there is a region disposed inside of the two projections 45 in the longitudinal direction. In addition, the second abutting portion 53x is provided at each of two positions on the shutter body portion 53m of the second shutter 53, but, the present invention is not limited to this structure, and one may be provide as shown in Figure 14.

[0103] In addition, in this embodiment, the extending portion 53y is formed integrally with the second shutter 53, but they may be formed separately. In addition, the second abutting portion 53x is formed integrally with the extending portion 53y, but they may be formed as separate members.

[0104] As shown in part (c) of Figure 5, the toner cartridge E is seen along the longitudinal direction. The state in which the second shutter 53 is opened from the state (part (c) in Figure 5) in which the third opening portion 49 is closed (part (d) in Figure 5) is obtained. At this time, the two projections 45 are arranged on the side approaching the second abutting portion 53x of the second shutter 53.

[0105] As shown in part (a) of Figure 5, the opposite end portions 53n, in the longitudinal direction, of the second shutter 53 (shutter body portion 53m) are

engaged with second shutter guide portions (opening/closing guides) 52 provided on opposite sides, in the longitudinal direction, of the third opening portion 49 of the container frame 47a. And, the structure is such that the shutter body portion 53m of the second shutter 53 is slidable in the circumferential direction on the outer peripheral surface of the container frame 47a along the second shutter guide portion 52. By this, the second shutter 53 is movable between the opening portion (part (d) of Figure 5) in which the third opening portion 49 is opened, and a second position in which the third opening portion 49 is closed (container closed position, part (c) in Figure 5) along the outer peripheral surface of the toner cartridge E.

[0106] Here, when the second shutter 53 is in the open position, it is preferable that the third opening portion 49 is entirely opened from the shutter body portion 53m (closed portion), as shown in part (d) of Figure 5. However, if the toner t can be discharged by the required amount from the third opening portion 49 when the second shutter 53 is in the open position, it is also possible to employ a structure in which a portion of the third opening portion 49 is covered with the shutter body portion 53m (closing portion). That is, any structure may be used as long as when the second shutter 53 is in the open position, the shutter body 53m at least partially opens the third opening portion 49, so that the toner t can be supplied from the toner cartridge E to the developing unit D.

[0107] In addition, it is preferable that when the second shutter 53 is in the closed position, as shown in part (c) of Figure 5, the entirety of the third opening portion 49 are covered by the shutter body 53m. However, the third opening portion 49 may be slightly opened provided that the third opening portion 49 is substantially closed by the shutter body portion 53m and the toner is sufficiently suppressed from leaking out through the third opening portion 49. That is, it will suffice if the shutter body 53m substantially closes the third opening portion

49 when the second shutter 53 is in the closing position.

[Mounting of toner cartridge to developing unit]

[0108] Next, the process of mounting the toner cartridge E to the developing unit D will be described. More specifically, by rotating the toner cartridge E with the toner cartridge E inserted into the developing unit D, the second opening portion 30 and the third opening portion 49 are opened and closed.

(Inserting Operation of Toner Cartridge into Developing Unit)

[0109] Referring to Figure 1, Figure 6 and Figure 7, the operation of inserting the toner cartridge E into the developing unit D will be described. Here, for the sake of convenience in explanation, in Figure 1, part (b) of Figure 6, and Figure, the insertion guided portions 35d and 36d are seen through.

[0110] Part (a) of Figure 1 is a side view as viewed from the side opposite to the second drive transmission portion 48 along the longitudinal direction when the toner cartridge E is inserted into the developing unit D. Part (b) of Figure 1 is a side view of the toner cartridge E and the developing unit D as viewed from the driving side, and shows a positional relationship of the operating portion 44 and the abutting portion 43a in the mounting direction of the toner cartridge E. Figure 6 is a schematic illustration of the toner cartridge E and the developing unit D in a state before the toner cartridge E is mounted (inserted), wherein part (a) of Figure 6 is a perspective view thereof, and part (b) of Figure 6 is a side view thereof.

[0111] Figure 7 is a side view of the toner cartridge E and the developing unit D in the state of mounting (inserting) the toner cartridge E.

[0112] As shown in part (a) of Figure 1, and the toner cartridge E includes a rotation guided portion (to be guided for rotation) 42b. This rotation guided portion 42b is a rotation guide (toner cartridge side rotation guide) for guiding the

container frame 47a when the toner cartridge E is rotated to open and close the first shutter 37 and the second shutter 53. The rotation guided portion 42b has a curved surface shape (substantially circular arc shape) extending around the rotation axis S of the toner cartridge E (details will be described later).

5 **[0113]** In this embodiment, on the non-driving side, the abutting portion 42a, the rotation guided portion 42b, the restricting portion 42c1, and the restricting portion 42c2 are formed integrally with a insertion guided portion (to be guided for insertion) 42b. However, they may be provided as separate members as long as they satisfy the respective functions.

10 **[0114]** As shown in part (b) of Figure 1, the insertion guided portion 43 has an abutting portion 43a abutting to the abutted portion 36a of the developing unit D when inserting the toner cartridge E. The insertion guided portion 43 also serves as a rotation guided portion (toner cartridge side rotation guided portion) for guiding the container frame 47a when the abutting portion 43a opens and
15 closes the first shutter 37 and the second shutter 53.

[0115] In this embodiment, on the driving side, the insertion guided portion 43b and the abutting portion 43a may be constituted by separate members. In addition, the rotated guide portion may be a member different from the abutting portion 43a. As described above, the portions (non-functional portions, non-
20 contact portions) where the toner cartridge E and the developing unit D do not abut each other may be appropriately omitted, taking the strength and the like into consideration.

[0116] In addition, in this embodiment, the insertion guided portion 43 is provided at the end portion of the second drive transmission portion 48 of the end
25 portion in the longitudinal direction of the second toner feeding portion 46. However, the insertion guided portion 43 may be provided on the container frame 47a.

[0117] Here, referring to part (a) of Figure 1, the position of the operating portion 44 in the container frame 47a will be described. Part (a) of Figure 1 is a side view of the side opposite to the second driving force transmitting portion 48 as the toner cartridge E is viewed in the longitudinal direction of the second toner feeding portion 46. In this Figure, the positional relationship between the operating portion 44 and the abutting portion 42a with respect to the inserting direction f is shown.

[0118] Here, the inserting direction f will be described. The direction along the surface of the restricting portion 42c is the f direction. More specifically, among the directions along the surface of the regulating portion 42c, the direction in which the abutting portion 42a is on the downstream side with respect to the insertion guided portion 42 can be said to be the f direction. That is, the direction in which the toner cartridge E is inserted into the developing unit D is the f direction.

[0119] The plane (an imaginary plane passing through the rotation center S of the container frame 47a) which is parallel to the inserting direction f of the restricting portion 42c1 and the toner cartridge E regulated by the restricting portion 42c1 and which passes through the abutting portion 42a and the abutting portion 43a is a plane m.

[0120] The operating portion 44 is placed on the downstream side of the plane m (direction e in part (a) of Figure 1) in the opening direction of the third opening portion 49 (part (d) of Figure 5). Here, the opening direction (direction of arrow e) of the third opening portion 49 is a direction (setting direction) in which the toner cartridge E is rotated to set the toner cartridge E to the developing unit D.

[0121] Next, the operation of inserting the toner cartridge into the developing unit will be described.

[0122] As shown in part (a) of Figure 6, before the toner cartridge E is

mounted on the developing unit D, the first shutter 37 is in the closing position for closing the second opening portion 30 (not shown), and the second shutter 53 is in the closing position for closing the third opening portion 49 (not shown). That is, the second opening portion 30 (part (b) of Figure 4) of the developing unit D and the third opening portion 49 (part (e) of Figure 5) of the toner cartridge E are closed by the first shutter 37 and the second shutter 53, respectively.

[0123] The insertion guided portion 42 of the toner cartridge E is provided with a restricted portion 42c1 and 42c2 (a restricted surface, an attitude restricting portion, an inserting direction restricting portion) for regulating the insertion attitude and dismounting attitude (inserting direction, removal direction) of the cartridge E in the mounting.

[0124] The user grips the operating portion 44 and moves the toner cartridge E relative to the developing unit D in the inserting direction f. The user moves the toner cartridge E such that the insertion guided portion 42 of the toner cartridge E and the insertion guide portion 35d of the developing unit D are engaged with each other, and the insertion guided portion 43 and the insertion guide portion 36d are engaged with each other. As the insertion guided portions 42, 43 are guided by the insertion guide portions 35d, 36d of the developing unit D, the attitude of the toner cartridge E when the toner cartridge E is mounted is stabilized.

[0125] Here, as shown in part (b) of Figure 6, in this embodiment, the insertion guided portions 42, 43 and the insertion guide portions 35d, 36d are constituted so that the inserting direction f is inclined relative to the gravity direction g.

[0126] In other words, the toner cartridge E is inserted, while the restricted portion 42c1 on the lower side, in the direction of gravity g, of the insertion

guided portion 42 and the surface 35d1 on the lower side, in the direction of gravity g, of the insertion guide portion 35d are in contact with each other (part (a) of Figure 1). Similarly, the toner cartridge E is inserted, while the restricting portion 42c2 on the lower side, in the direction of gravity g, of the insertion guided portion 42 and the surface 35d2 on the lower side, in the direction of gravity g, of the insertion guide portion 35d are in contact with each other (part (b) of Figure 1).

[0127] And, as shown in Figure 7, the restricting portion 42c1 on the lower side, in the direction of gravity g, of the insertion guided portion 42 rides on the surface 35d1 of the insertion guide portion 35d, by which the positions of the insertion guided portion 42 relative to the insertion guide portion 35d and the rotation guide portion 35b is determined in the direction other than the f direction. By this, the attitude of the toner cartridge E with respect to the developing unit D is determined.

[0128] As shown in part (a) of Figure 1, the insertion guided portion 42 provided in the toner cartridge E is provided with an abutting portion 42a. As the user moves the toner cartridge E further in the f direction while maintaining its attitude, the abutting portion 42a abuts to the abutted portion 35a provided in the developing unit D. Similarly, as shown in part (b) of Figure 1, the abutting portion 43a provided on the toner cartridge E abuts against the abutted portion 36a provided in the developing unit D. By this, the insertion of the toner cartridge E is completed.

(Positioning of toner cartridge relative to developing unit)

[0129] Referring to part (a) of Figure 10, part (b) of Figure 10, part (a) of Figure 11, part (b) of Figure 11, the positioning of the toner cartridge E relative to the developing unit D will be described.

[0130] Part (a) of Figure 10 is a side view of the insertion guided portion 42 of

the toner cartridge E and the frame 35 of the developing unit D in a state that the abutting portion 42a and the abutted portion 35a are abutted to each other. Part (b) of Figure 10 is a sectional view of the toner cartridge E and the developing unit D in a state in which the abutting portion 42a and the abutted portion 35a
5 abut to each other.

[0131] Part (a) of Figure 11 is a side view of the insertion guided portion 42 of the toner cartridge E and the frame 35 of the developing unit D in a state that the toner cartridge E is positioned relative to the developing unit D. Part (b) of Figure 11 is a sectional view illustrating the engaging relationship between the
10 toner cartridge E and the developing unit D which are positioned. More specifically, part (b) of Figure 11 is a cross-sectional view of the toner cartridge E and the developing unit D, taken along a plane passing through the position of the second shutter 53.

[0132] Part (a) of Figure 10 shows a state after completion of insertion of the
15 toner cartridge E into the developing unit D. In order to open and close the first shutter 37 and the second shutter 53, the container 47 is rotated in the direction of the arrow e around the rotation axis S of the toner cartridge E. Then, as shown in part (a) of Figure 11, the abutting portion 42a and the rotation guided portion 42b are engaged with the rotation guide portion 35b. By this, the toner cartridge
20 E is positioned relative to the developing unit D. At this time, the rotation guided portion 42b is guided by the rotation guide portion 35b provided in the developing unit D. By this, the container 47 can rotate smoothly.

[Opening and Closing Operation of Shutter]

25 **[0133]** In the following, the opening and closing operations of the first shutter 37 provided in the developing unit D and the second shutter 53 provided in the toner cartridge E will be described in detail.

[0134] In this embodiment, in the course of mounting the toner cartridge E to the developing unit D, the first shutter 37 of the developing unit D and the second shutter 53 of the toner cartridge E open the second opening portion 30 and the third opening portion 49 (move to the open positions), respectively. On the
5 contrary, in the process in which the toner cartridge E is removed from the developing unit D, the first shutter 37 and the second shutter 53 close the second opening portion 30 and the third opening portion 49, respectively (move to the closed positions).

[0135] The toner cartridge E is mounted to the developing unit D at least by a
10 mounting operation including a rotating operation. More specifically, after the toner cartridge E is linearly inserted into the developing unit D, it is mounted with rotation relative to the developing unit D. In interrelation with the rotating operation in the mounting of the toner cartridge E, the first shutter 37 and the second shutter 53 move from the closed position to the open position,
15 respectively.

[0136] Similarly, the toner cartridge E is dismounted from the developing unit D by a dismounting operation including at least a rotating operation. More specifically, after rotating relative to the developing unit D, the toner cartridge E is dismounted from the developing unit D substantially linearly.

20 **[0137]** The first shutter 37 and the second shutter 53 move to the open position as the toner cartridge E is rotated at the time of removal.

(Opening Operation of Shutter)

[0138] Refer to part (a) of Figure 1, part (b) of Figure 10, part (a) of Figure 11, part (b) of Figure 11, part (a) of Figure 12 and part (b) of Figure 12, the opening
25 operation of the first shutter 37 of the developing unit D and the second shutter 53 of the toner cartridge E will be described. Part (a) of Figure 12 is a side view of the insertion guided portion 42 of the toner cartridge E and the frame 35 of the

developing unit D in the state in which the second opening portion 30 and the third opening portion 49 are opened. Part (b) of Figure 12 is a sectional view of the toner cartridge E and the developing unit D in the state in which the second opening portion 30 and the third opening portion 49 are opened.

5 **[0139]** In this embodiment, the relative positions of the second opening portion 30 and the third opening portion 49 can be different from each other in a state where the toner cartridge E is positioned relative to the developing unit D (mounted state). In other words, the structure is such that by rotating the toner cartridge E, it is possible to take at least two positions (two states) in the state that
10 the toner cartridge E is mounted to the developing unit D.

[0140] The first position of the toner cartridge E is a non-communicating position (part (b) of Figure 10) in which the second opening portion 30 and the third opening portion 49 do not overlap so that the first toner containing portion 28 and the second toner containing portion 47t are not in communication with
15 each other. In this state, the first shutter 37 is in the closed position closing the second opening portion 30.

[0141] The second position of the toner cartridge E is a communication position (part (b) of Figure 12) in which the second opening portion 30 and the third opening portion 49 overlap so that the first toner containing portion 28 and
20 the second toner containing portion 47t are in communication with each other. In this state, the first shutter 37 is in the open position where the second opening portion 30 is opened.

[0142] As shown in part (a) of Figure 1, when the toner cartridge E is inserted into a predetermined position of the developing unit D, the projection 45 of the
25 container frame 47a and the hole portion 37a of the first shutter 37 are engaged with each other.

That is, the insertion guided portion 42 is guided by the insertion

guide portion 35d, by which the insertion attitude of the toner cartridge E is restricted so that the projection 45 can be inserted into the hole portion 37a.

[0143] In addition, when the toner cartridge E is inserted into a predetermined position of the developing unit D, the first abutting portion 53c of the second shutter 53 and the collision surface (opening force applying portion) 39 of the developing unit D face each other. That is, the insertion guided portion 42 is guided by the insertion guide portion 35d, by which the insertion attitude of the toner cartridge E is restricted so that the first abutting portion 53c faces the collision surface 39.

[0144] In addition, the second abutting portion 53x of the second shutter 53 and the toner receiving portion 35x of the developing unit D face each other. That is, the insertion guided portion 42 is guided by the insertion guide portion 35d, by which the insertion attitude of the toner cartridge E is restricted so that the second abutting portion 53x of the second shutter 53 and the toner receiving portion 35x of the developing unit D face each other.

[0145] By the operation of the operating unit 44 of the toner cartridge E by the user, the container frame 47a is rotated in the direction of arrow e from the mounting position shown in part (a) of Figure 1. By this, the state of engagement between the insertion guided portion 42 and the frame 35 is changed from the state shown in part (a) of Figure 11 to the state in which the second opening portion 30 and the third opening portion 49 shown in part (a) of Figure 12 overlap each other (not shown). At this time, the rotation axis S of the toner cartridge E (container frame 47a) is substantially parallel to the longitudinal direction of the toner cartridge E.

[0146] When container frame 47a starts to rotate in the direction of arrow e, as shown in part (b) of Figure 10, the surface 53c1 on the downstream side, in the direction of the arrow e, of the first abutting portion 53c abuts against the

collision surface 39 provided on the developing unit D. By this, the surface 53c1 receives the force F1 from the collision surface 39 of the developing unit D. And, as shown in part (b) of Figure 11, during rotation of the container frame 47a in the direction of arrow e, the surface 53c1 continues to receive the force F1
5 from the collision surface 39. Therefore, the second shutter 53 does not rotate in the direction of arrow e simultaneously together with the container frame 47a.

[0147] That is, the collision surface 39 restricts the rotation of the second shutter 53 simultaneously together with the container frame 47a in the direction of the arrow e. The force F1 received by the first abutting portion 53c is a force
10 for moving the second shutter 53 from the closed position to the open position.

[0148] From this state, the container frame 47a is further rotated in a direction (direction of arrow e) in which the toner cartridge E is mounted to the developing unit D. Then, the container frame 47a moves in a direction (opening direction) in which the third opening portion 49 for supplying the toner to the developing
15 unit is opened.

[0149] In other words, the second shutter moves relative to the container frame 47a in the direction of opening the third opening portion 49.

[0150] In addition, as shown in part (b) of Figure 11, when the container frame 47a rotates in the direction of the arrow e, the surface 45a of the projection 45 and the surface 37a1 of the hole portion 37a come into contact with each other,
20 so that a force F3 is applied from the surface 45a to the surface 37a1. By this, the first shutter 37 is pushed in the rotational direction (the direction of the arrow e) of the container frame 47a. As a result, the first shutter 37 moves in interrelation with the rotation of the container frame 47a, so that the second
25 opening portion 30 is opened. The projection (projection, projection) 45 provided on the container frame 47a is a release force applying portion (open position moving portion, opening/closing member moving portion) for applying a

force to the first shutter 37 to move the first shutter 37 to the open position.

[0151] Thereafter, as shown in part (a) of Figure 12 and part (b) of Figure 12, the first toner containing portion 28 and the second toner containing portion 47 are in a state of communication through the third opening portion 49 and the second opening portion 30. By this, the opening operation of the second opening portion 30 and the third opening portion 49 is completed.

[0152] At this time, the abutting portion 42a and the rotation guided portion 42b are engaged with the rotation guide portion 35b. By this, the relative movement of the toner cartridge E in the direction of the arrow e relative to the developing unit D is restricted in a state that the second opening portion 30 and the third opening portion 49 are opened.

[0153] In this state, the second drive transmission portion 48 of the toner cartridge E is connected (not shown) to the drive transmission portion 38 (part (a) of Figure 4) of the development unit D. By this, the driving force for rotating the second toner feeding member 46 is in a state of ready for transmission from the developing unit D.

[0154] From the foregoing, transportation (supply) of the toner t from the second toner containing portion 47t of the toner cartridge E to the first toner containing portion 28 of the developing unit D is enabled. Here, in this embodiment, the drive transmission portion 38 for transmitting the drive to the second drive transmission portion 48 of the toner cartridge E is provided on the developing unit D side.

[0155] However, as shown in Figure 14, a drive transmission portion 38 which meshes with the second drive transmission portion 48 may be provided on the toner cartridge E side. Here, Figure 14 is a side view of the toner cartridge E as viewed from the drive side in the case where a drive transmission portion 38 meshing with the second drive transmission portion 48 is provided. In part (a)

of Figure 14, the third opening portion 49 (not shown) is closed by the second shutter 52. In addition, part (b) of Figure 14 shows a state in which the third opening portion 49 (not shown) is opened.

[0156] In the modification shown in Figure 14, two gears are provided on the toner cartridge E. The drive transmission gear 38 is a drive input gear for receiving a driving force from the developing unit D. And, the second drive transmission portion 48 transmits the driving force received by the drive input gear (drive transmission portion 38) as the second gear (transmission gear) to the second toner feeding member 46 (part (b) of Figure 12). The second drive transmission portion 48 and the second toner feed member 46 are coaxially arranged.

[0157] Here, the engagement between the gears is called a meshing, and even when a belt or the like provided with the projection engages, it is considered as meshing.

(Switching from toner cartridge inserting operation to shutter opening operation)

[0158] Next, referring to parts (a) of Figures 1, 9, and part (b) of Figure 9, the switching operation from the inserting operation of the toner cartridge E to the shutter opening operation which is a feature of this embodiment will be described. Part (a) of Figure 9 is a side view illustrating the force relationship on the toner cartridge E when the insertion into the developing unit D is completed. In addition, part (b) of Figure 9 is a side view illustrating a force relationship on the toner cartridge E in another structure example of the abutting portion 42a.

[0159] Here, for the sake of convenience of explanation, the insertion guided portion 35d is seen through.

[0160] As shown in part (a) of Figure 9, the toner cartridge E is inserted into the developing unit D by a user operation, and the abutting portion 42a and the abutted portion 35a abut each other. At this time, a force F6 and a force F7 act

on the toner cartridge E. More specifically, the force F6 applied when the toner cartridge E is inserted by the user acts on the operating portion 44, and the equivalent reaction force F7 acts to the abutting portion 42a of the insertion guided portion 42.

5 **[0161]** Here, a plane (imaginary plane) m that is parallel to the mounting direction of the toner cartridge E passing through the rotation axis S of the toner cartridge E (rotation center of the second shutter member 53) is taken. The length of the arm from the imaginary surface m to the operating portion 44 is r1, and the length of the arm from the rotational axis (rotation center) S to the
10 abutting portion 42a is r2. At this time, the moment M acting on the rotational axis S of the third opening portion 49 (part (d) of Figure 5) of the toner cartridge E can be expressed by the following equation.

$$M = F6 \times r1 + F7 \times r2$$

[0162] In addition, as shown in part (a) of Figure 9, when the second opening
15 portion 30 and the third opening portion 49 are opened, the rotational direction of the toner cartridge E (the container frame 47a) is the counterclockwise arrow e direction as the toner cartridge E is viewed along the axial direction of rotation of the container frame 47a. Here, in this embodiment, the abutting portion 42a is positioned on a plane (imaginary plane) m passing through the rotation center S
20 of the container frame 47a and parallel to the inserting direction (guide direction) f, and therefore, r2 = 0. Also, the operating portion 44 is provided on the downstream side of the plane m in the rotational direction e when the opening direction (the direction of the arrow e) of the second opening portion 30 and the third opening portion 49 is forward.

25 **[0163]** Therefore, $F6 \times r1 > 0$, and therefore, $M > 0$.

[0164] Since $F6 \times r1 > 0$ and $M > 0$, a force F6 applied by the user when the toner cartridge E is inserted into the developing unit D is converted into a force to

rotate the second opening portion 30 and the third opening portion 49 in the opening direction e. Therefore, the whole toner cartridge E is rotated by the force F6 in the direction of inserting the toner cartridge E in the direction f.

[0165] Here, the larger the value of the moment M is, the more easily the toner cartridge E is rotated. In other words, the larger the value of the moment M, the easier and smoother it is to operate the opening operation of the second opening portion 30 and the third opening portion 49.

[0166] Here, as a structure for increasing the moment M, as shown in part (b) of Figure 9, it is conceivable to change the position where the abutting portion 42a is provided, for example. More specifically, it is conceivable that the abutting portion 42a is placed at a position passing through the rotation center S of the container frame 47a and apart from the imaginary surface m parallel to the mounting direction f on the side opposite to the operating portion 44.

[0167] Assuming that the force acting on the abutting portion 42a is F8 and the distance from the imaginary plane m to the abutting portion 42a is r3, the moment M acting on the rotation center S can be expressed by the following equation as with the structure in part (a) of Figure 9.

$$M = F6 \times r1 + F8 \times r3$$

[0168] At this time, F8 x r3 is a moment in the opening direction e of the second opening portion 30 and the third opening portion 49. Therefore, the moment M becomes large, and therefore the container frame 47a is easy to rotate in the opening direction e. Here, the above-described positional relationship between the abutting portion 42a and the operating portion 44 can be applied to the relationship between the abutting portion 43a and the operating portion 44 to provide the same effects.

(Closing Operation of Shutter)

[0169] Referring to part (a) of Figure 10, part (b) of Figure 10, part (b) of

Figure 11, part (b) of Figure 12, the closing operation of the first shutter 37 of the developing unit D and the second shutter 53 of the toner cartridge E will be described. The closing operation of the first shutter 37 and the second shutter 53 is performed in the opposite operation to the opening operation described above. Here, the closing direction of the first shutter 37 and the second shutter 53 is the direction in which the container frame 47a rotates in the clockwise direction (the direction of the arrow h in part (b) of Figure 12) as viewed in the axial direction from the side opposite to the side of the second drive transmission portion 48 provided.

10 **[0170]** First, in the state of part (b) of Figure 12, the user operates the operating portion 44 to rotate the container frame 47a in the closing direction (the direction of arrow h, the closing direction). Then, as shown in part (b) of Figure 11, the surface 45b of the projection 45 of the container frame 47a abuts to the surface 37a2 of the hole portion 37a of the first shutter 37 so that a force F4 is applied from the surface 45b to the surface 37a2. By this, the surface 37a2 of the first shutter 37 receives a force in the direction of the arrow h from the surface 45b to rotate in interrelation with the rotating operation of the container 47. And, the first shutter 37 moves to the closed position where the first shutter 37 closes the second opening portion 30. The surface 45b of the projection 45 is a closing force applying portion which moves the first shutter 37 to the closed position by applying a force to the first shutter 37.

20 **[0171]** In addition, in the state of Figure 12, the user operates the operating portion 44 to rotate the container frame 47a in the closing direction (the direction of arrow h, the closing direction). When container frame 47a starts to rotate in the direction of arrow h, as shown in part (b) of Figure 12, the surface 53x1 of the second abutting portion 53x provided on the second shutter 53 on the downstream side in the direction of the arrow h abuts to the surface 35x1 on the upstream side,

in the direction of arrow h, of the toner receiving portion 35x. By this, the surface 53x1 receives the force F2 from the surface 35x1. For this reason, even when the container frame 47a rotates in the direction of the arrow h, the surface 53x1 continues to receive the force F2 from the surface 35x1. Therefore, the extending portion 53y provided with the second abutting portion 53x does not rotate together with the container frame 47a in the direction of the arrow h.

[0172] That is, the toner receiving portion 35y regulates rotation of the second abutting portion 53x together with the container frame 47a in the direction of arrow h. The force F2 received by the second abutting portion 53x is a force for moving the second shutter 53 from the open position to the closing position.

[0173] And, when the container frame 47a is further rotated in the closing direction (direction of arrow h), as shown in part (a) of Figure 10 and part (b) of Figure 10, the toner cartridge E can be removed from the developing unit D. At this time, the second opening portion 30 and the third opening portion 49 are closed by the first shutter 37 and the second shutter 53, respectively.

[0174] In the state that the toner cartridge E has been inserted in the mounting position of the developing unit D, the operating portion 44 is positioned on the downstream side, in the rotational direction, of the container frame 47a, relative to an imaginary line passing through the center of rotation and extending in the inserting direction f, as seen in the direction of the axis of rotation of the container frame 47a. The structure is such that in this position, the operating unit 44 receives a force to rotate the container frame 47a by the user's operation. This position is a position where a moment acting to rotate the container frame 47a relative to the developing unit D occurs when the operating portion 44 receives a force acting in the inserting direction f.

[0175] In other words, in the case of the structure of the toner cartridge E according to this embodiment, the force (arrow R in Figure 9) acting on the

operating portion 44 when rotating the container frame 47a at this position is a component force in the inserting direction f (Figure 9, arrow Rf). As the user applies force in the inserting direction f to the operating portion 44 at the time of insertion, a force in the inserting direction f acts on the operating portion 44 at the time when the toner cartridge E reaches the mounting position. That is, at the time when the toner cartridge E reaches the mounting position, a portion of the force required to rotate the container frame 47a has already been applied to the operating unit 44. Therefore, by the operation of the user pushing the operating unit 44 in the inserting direction f , the force in the inserting direction f continues to be applied to the operating portion 44 also when the container frame 47a rotates following insertion of the toner cartridge E into the mounting position.

[0176] By this, in the series of mounting operation in which the user grips the operating portion (grip portion) 44, inserts the toner cartridge E to the mounting position of the developing unit D and then rotates the container frame 47a, the force is smoothly converted from the inserting operation to the rotating operation. Therefore, the user can intuitively operate the insertion of the toner cartridge E into the developing unit D and the opening operation of the first shutter 37 and the second shutter 53, thereby significantly improving operability.

[0177] In addition, in this embodiment. The structure is such that as viewed in the direction of the rotation axis of the container frame 47a, the operating portion (gripping portion) 44 receives a force at a position more remote from the rotation center than the abutting portion 42a, when the toner cartridge E is at the mounting position. By this, the container frame 47a can be rotated with a small force against the sliding resistance between the abutting portion 42a and the abutted portion 35a and the rotation guide portion 35b when the container frame 47a rotates, by the principle of leverage. The same applies to the sliding resistance between the abutting portion 43a and the abutted portion 36a and the

rotating guide 36b.

(Modifications of Extending Portion and Abutting Portion)

[0178] Referring to Figure 8, modified examples of the extending portion and the abutting portion provided on the second shutter 53 will be described. Part (a) of Figure 8 is a side sectional view illustrating a modified example of the extending portion 53y, when the toner cartridge E is inserted into a predetermined position of the developing unit D. Part (b) of Figure 8 is a side sectional view illustrating a modified example of the first abutting portion 53 c, when the toner cartridge E is inserted into a predetermined position of the developing unit D.

[0179] As shown in Figure 1, in this embodiment, as seen along the longitudinal direction, the cross-sectional shape of the extending portion 53y is an arcuate shape on the extended line of the second shutter 53. However, the shape of the extending portion 53y is not limited to the arcuate shape. As shown in part (a) of Figure 8, as seen along the longitudinal direction, the cross-sectional shape of the extending portion 53y may be a polygonal. Even in this case, when the toner cartridge E is inserted into a predetermined position of the developing unit D, the surface 53x1 of the second abutting portion 53x on the downstream side in the direction of arrow h faces the surface 35x1 on the upstream side, in the direction of arrow h, of the toner receiving portion 35x1.

[0180] As described in the foregoing, as seen along the longitudinal direction, the extending portion 53y is not limited to be provided in an arc shape on the extended line of the second shutter 53.

[0181] In this example, the first abutting portion (opening force receiving portion) 53c is provided at the leading end of the second shutter 53, and the second abutting portion (closing force receiving portion) 53x is provided at the extending portion 53y of the second shutter 53. However, as shown in Figure 8, / both the first abutting portion (opening force receiving portion) 53c and the

second abutting portion (closing force receiving portion) 53x may be provided on the extending portion 53y.

[0182] Here, Figure 8 is a side sectional view of the toner cartridge E as seen from the opposite side in the longitudinal direction with respect to the driving side, when the toner cartridge E is inserted into a predetermined position of the developing unit D.

[0183] In Figure 8, the first abutting portion (opening force receiving portion) 53c and the second abutting portion (closing force receiving portion) 53x are disposed adjacent to each other, at the end of the extending portion 53y (that is, the trailing end of the second shutter 53).

[0184] At this time, the insertion attitude of the toner cartridge E is restricted so that the surface 53x1, on the downstream side, in the direction of arrow h, of the second abutting portion 53x provided on the extending portion 53y faces the surface 35x1 on the upstream side, in the direction of arrow h, of the toner receiving portion 35x. The user operates the operating portion 44 to rotate the container frame 47a in the closing direction (direction of arrow h). At this time, as with the previously described structure, the surface 53x1 abuts to the surface 35x1. By this, the surface 53x1 receives the force F2 from the surface 35x1. For this reason, even when the container frame 47a rotates in the direction of the arrow h, the surface 53x1 continues to receive the force F2 from the surface 35x1. Therefore, the second shutter 53 provided with the second abutting portion 53x does not rotate together with the container frame 47a in the direction of the arrow h. Thus, the second shutter 53 moves relative to the container frame 47a to the closed position where the third opening portion 49 is closed.

[0185] In addition, the insertion attitude of the toner cartridge E is restricted such that the surface 53c1 on the upstream side, in the direction of arrow h, of the first abutting portion 53c provided on the extending portion 53y faces the surface

35x2 on the downstream side, in the direction of arrow h, of the toner receiving portion 35x. The user operates the operating unit 44 to rotate the container frame 47a in the opening direction (direction of the arrow e). At this time, the surface 53c1 abuts to the surface 35x2. By this, the surface 53c1 receives the force F5 from the surface 35x2. For this reason, even when the rotation of the container frame 47a in the direction of arrow h proceeds, the surface 53c1 continues to receive the force F5 from the surface 35x2. Therefore, the second shutter 53 provided with the first abutting portion 53c does not rotate together with the container frame 47a in the direction of arrow h.

10 Therefore, the second shutter 53 moves relative to the container frame 47a to a closed position where it closes the third opening portion 49.

[0186] As described above, the first abutting portion 53c may be provided on the extending portion 53y.

(Modified example of developing unit D)

15 **[0187]** Next, referring to Figure 15 and Figure 16, a modified example of the developing unit D will be described. Figure 15 is a perspective view illustrating a periphery of the first shutter 37 of the developing unit D, wherein part (a) shows a state where the first shutter 37 is opened, and part (b) shows a closed state.

Figure 16 is a sectional view of the toner cartridge E and the developing unit D.

20 Part (a) of Figure 16 shows a process of inserting the toner cartridge E into the developing unit D, and part (b) shows a state where the insertion of the toner cartridge E is completed. In addition, part (c) of Figure 16 is an enlarged view of portion of part (b) of Figure 16.

[0188] In this modified example, a lock arm (receiving apparatus side lock member) 61 is provided in the developing unit D, in order to prevent the first shutter 37 from unintentionally opening. As shown in Figure 15, two lock arms 61 are provided on the developing unit D, and each of the lock arms 61 has a

claw portion (engaging portion, projecting portion, locking portion) 61a at the leading end thereof. In addition, the lock arm 61 can be elastically deformed.

[0189] The claw portion 61a of the lock arm 61 is located at the same position as the hole portion 37a of the first shutter 37 in the longitudinal direction of the developing unit D.

[0190] And, in a state in which the first shutter 37 closes the second opening portion 30, the claw portion 61a enters the hole portion 37a and engages with the hole portion 37a. By this, the claw portion 61a locks the movement of the first shutter 37 and suppresses unintended opening of the first shutter 37.

[0191] Here, in the course of inserting the toner cartridge E into the developing unit D, the two projections 45 provided on the toner cartridge E come into contact with the corresponding claw portions 61a as shown in part (b) of Figure 16. When the projection 45 comes into contact to the claw portion 61a, the lock arm 61 is elastically deformed, by which the claw portion 61a is retracted from the hole portion 37a, and the lock of the first shutter 37 is released. That is, the first shutter 37 becomes movable.

[0192] In the state shown in part (b) of Figure 16, when the toner cartridge E is rotated relative to the developing unit D, as mentioned above, the claw portion 45 is engaged with the hole portion 37a so that the first shutter 37 can move to the open position.

[0193] In addition, when the toner cartridge E is removed from the developing unit D, the claw portion 61a advances into the hole portion 37a in interrelation with the operation of retracting the projection portion 45 from the hole portion 37a to lock the first shutter 37 (part (a) of Figure 16).

[0194] In the present modified example described above, the projection 45 of the toner cartridge E serves as a releasing projection for releasing the lock by the lock arm 61.

(Summary)

[0195] In this embodiment, the second shutter 53 is constituted to be rotatable around the container 47 (container frame 47a). By this, the second shutter 53
5 can be opened and closed by an operation (rotating operation) in which the toner cartridge E rotates relative to the developing unit D (receiving device). By opening and closing the second shutter 53 with rotating operation of the toner cartridge E, there is provided an advantage that the space (space) necessary for opening and closing the second shutter 53 can be reduced as compared with the
10 case where the second shutter 53 is opened and closed by linear movement of the toner cartridge E.

[0196] That is, when the toner cartridge E rotates relative to the developing unit D, the toner cartridge E changes only the attitude thereof, and the center (rotation axis S) of the toner cartridge E hardly moves relative to the developing
15 unit D. That is, in the opening and closing operation of the second shutter 53, the area occupied by the toner cartridge E in the developing unit D hardly changes. As a result, it is unnecessary to provide a large space for the developing unit D in order to open and close the second shutter 53. That is, by employing the toner cartridge E as in this embodiment, the receiving apparatus
20 (developing unit D) for receiving the toner cartridge E and the image forming apparatus provided with the receiving apparatus are downsized.

[INDUSTRIAL APPLICABILITY]

[0197] According to the present invention, a toner cartridge for forming an
25 electrophotographic image and a toner supply mechanism are provided.

[Symbols]

- 16: Photosensitive drum (image bearing member)
- 17: Charging roller
- 19: Cleaning blade
- 24: Developing roller (developer carrying member)
- 5 25: Developing blade
- 27: First toner feeding means
- 28: First toner containing portion (developer accommodating portion)
- 29: First opening
- 30: Second opening (containing body opening, receiving port, receiving opening)
- 10 31: Developing chamber
- 32: First sealed seal
- 34: First shutter guide portion
- 35: Frame
- 35a: Abutted portion
- 15 35d: Insertion guide portion
- 36a: abutted portion
- 36d: Insertion guide portion
- 37: First shutter
- 37a: Hole
- 20 38: First drive transmission portion
- 42: Insertion guided portion (guided portion, toner cartridge side guide portion)
- 42a: Abutting portion
- 43: Insertion guided portion (guided portion, toner cartridge side guide portion)
- 43a: Abutting portion
- 25 44: Operating porrtion
- 45: Projection (container side engaging portion, opening/closing member moving portion, container side projection)

- 46: Second toner feeding member
- 47: Container
- 47a: Container frame
- 47a1: Side wall
- 5 47a2: Side wall
- 47t: Second toner container
- 48: Second drive transmission portion
- 49: Third opening (container opening, discharge opening, discharge opening)
- 53: Second shutter
- 10 53c: First abutting portion
- 53m: Shutter body
- 53x: Second abutting portion
- 53y: Extension part
- 54: Second sealed seal
- 15 58: Communication part
- A: Image forming apparatus
- C: Drum unit
- D: Developing unit
- E: Toner cartridge
- 20 F: Inserting direction
- T: Toner

WHAT IS CLAIMED IS

1. A toner cartridge detachably mountable to a receiving apparatus, said receiving apparatus including a toner receiving opening, a closing force applying portion, said toner cartridge comprising:

5 (1) a container including (1 - 1) an accommodating portion for accommodating toner, and (1 - 2) a discharge opening for discharging the toner from said accommodating portion;

(2) an open/close member including (2 - 1) for closing said discharge opening, and (2 - 2) a closing force receiving portion, said open/close member and being
10 movable relative to said container between a closing position for causing said closing portion to close said discharge opening and an opening position for causing said closing portion to open said discharge opening,

wherein said open/close member including a leading end portion and a trailing end portion which are on downstream and upstream sides of said
15 open/close member with respect to a closing direction in which said open/close member moves to close said discharge opening, respectively, and wherein said open/close member extends from the leading end portion to the trailing end portion in a range exceeding 180° of a circumference of said container, as said toner cartridge is seen in the longitudinal direction of said container,

20 wherein said closing force receiving portion is configured to receive a force for moving said open/close member from the opening position to the closing position when said toner cartridge is dismounted from said receiving apparatus.

25 2. A toner cartridge according to Claim 1, wherein said toner cartridge is dismountable from said receiving apparatus at least with rotating operation of said toner cartridge, and said closing force receiving portion receives the force

from said closing force applying portion with the rotating operation.

3. A toner cartridge according to Claim 1 or 2, wherein said closing force receiving portion is disposed adjacent to the trailing end of said open/close member.

4. A toner cartridge according to any one of Claims 1 - 3, wherein said open/close member is provided with an extended portion extending from said closing portion toward an upstream in the closing direction, and the trailing end of said open/close member is disposed on said extended portion.

5. A toner cartridge according to Claim 4, wherein said closing force receiving portion is provided on said extended portion.

6. A toner cartridge according to Claim 4 or 5, wherein said open/close member is provided with a plurality of such said extended portions, and said closing force receiving portion is provided on each of said extended portions.

7. A toner cartridge according to any one of Claims 1 - 6, wherein said closing force receiving portion is provided with a projection projecting in a direction away from said container.

8. A toner cartridge according to any one of Claims 1 - 7, further comprising an opening force receiving portion, wherein said opening force receiving portion is configured to receive, from an opening force applying portion provided in the receiving apparatus, a force for moving said open/close member from the closing position to the opening position.

9. A toner cartridge according to Claim 8, wherein said opening force receiving portion is disposed adjacent to the leading end portion of said open/close member.

5

10. A toner cartridge according to Claim 8, wherein said opening force receiving portion and said closing force receiving portion are disposed adjacent the trailing end of said open/close member.

10 11. A toner cartridge according to any one of Claims 8 - 10, wherein said opening force receiving portion is disposed adjacent to said closing force receiving portion.

15 12. A toner cartridge according to any one of Claims 8 - 11, wherein said opening force receiving portion is provided with a projection projecting in a direction away from said container.

20 13. A toner cartridge according to any one of Claims 1 - 12, wherein said closing force receiving portion is disposed adjacent to the trailing end of said open/close member.

25 14. A toner cartridge according to any one of Claims 1 - 13, wherein said container is provided with two projections at positions along a longitudinal direction of said container, said projections projecting toward an upstream side in a removing direction in which said toner cartridge is removed from the receiving apparatus.

15. A toner cartridge according to Claim 14, wherein when said open/close member moves from the opening position to the closing position, said leading end portion approaching to said two projections.

5 16. A toner cartridge according to Claim 14 or 15, wherein said receiving apparatus includes a receiving apparatus side openable member for opening and closing said receiving opening, and a locking portion for locking the receiving apparatus side openable member at a position covering said receiving opening, and wherein said two projections are capable of unlocking said locking portion.

10

17. A toner cartridge according to any one of Claims 14 - 16, wherein as said two projections and said discharge opening are projected onto an imaginary line extending in a longitudinal direction of said container, at least a part of a projection area of said discharge opening is sandwiched between projection areas
15 of said two projections.

15

18. A toner cartridge according to any one of Claims 14 - 16, wherein as said two projections and said discharge opening are projected onto an imaginary line extending in a longitudinal direction of said container, an entirety of a
20 projection area of said discharge opening is sandwiched between projection areas of said two projections.

20

19. A toner cartridge according to any one of Claims 1 - 18, further comprising a drive input gear for receiving a driving force from the receiving
25 apparatus.

25

20. A toner cartridge according to any one of Claims 1 - 19, wherein said

closing force receiving portion approaches to an axis of said drive input gear by movement of said open/close member from the closing position to the opening position.

5 21. A toner cartridge according to Claim 20, further comprising a feeding member for feeding the toner toward said discharge opening by the driving force received by said drive input gear.

10 22. A toner cartridge according to Claim 21, further comprising a transmission gear for transmitting the driving force from said drive input gear toward said feeding member.

15 23. A toner cartridge according to any one of Claims 1 - 22, wherein said open/close member extends from the leading end portion to the trailing end portion in a range of not less than 230° and not more than 270° of a circumference of said container, as said toner cartridge is seen in the longitudinal direction of said container.

20 24. A toner supply mechanism comprising said receiving apparatus and the toner cartridge according to any one of Claims 1 - 23.

25 25. A toner cartridge detachably mountable to a receiving apparatus, said receiving apparatus including a toner receiving opening, an opening force applying portion, said toner cartridge comprising:
a container including,
an accommodating portion for accommodating toner, and a discharge opening for discharging the toner from said accommodating portion;

an open/close member including,
a closing portion for closing said discharge opening, and an opening
force receiving portion,

wherein said open/close member is movable relative to said container
5 between a closing position for causing said closing portion to close said discharge
opening and an opening position for causing said closing portion to open said
discharge opening,

wherein said open/close member including a leading end portion and a
trailing end portion which are on downstream and upstream sides of said
10 open/close member with respect to a closing direction in which said open/close
member moves to close said discharge opening, respectively, and wherein said
open/close member extends from the leading end portion to the trailing end
portion in a range exceeding 180° of a circumference of said container, as said
toner cartridge is seen in the longitudinal direction of said container,

15 wherein said closing force receiving portion is configured to receive a
force for moving said open/close member from the closing position to the
opening position when said toner cartridge is mounted to said receiving apparatus.

26. A toner cartridge according to Claim 25, wherein said toner cartridge
20 is mountable to said receiving apparatus at least with rotating operation of said
toner cartridge, and said opening force receiving portion receives the force from
said opening force applying portion with the rotating operation.

27. A toner cartridge according to Claim 25 or 26, wherein said opening
25 force receiving portion is disposed adjacent to the leading end portion of said
open/close member.

28. A toner cartridge according to any one of Claims 25 - 27, wherein said open/close member is provided with an extended portion standing from said closing portion toward an upstream in the closing direction.

5 29. A toner cartridge according to any one of Claims 25 - 28, wherein said opening force receiving portion is provided with a projection projecting in a direction away from said container.

10 30. A toner cartridge according to any one of Claims 25 - 29, wherein said container is provided with two projections at positions along a longitudinal direction of said container, said projections projecting toward a downstream side in an inserting direction in which said toner cartridge is inserted into the receiving apparatus.

15 31. A toner cartridge according to Claim 30, wherein when said open/close member moves from the opening position to the closing position, said leading end portion approaching to said two projections.

20 32. A toner cartridge according to Claim 30 or 31, wherein said receiving apparatus includes a receiving apparatus side openable member for opening and closing said receiving opening, and a locking portion for locking the receiving apparatus side openable member at a position covering said receiving opening, and wherein said two projections are capable of unlocking said locking portion.

25 33. A toner cartridge according to any one of Claims 30 - 32, wherein as said two projections and said discharge opening are projected onto an imaginary line extending in a longitudinal direction of said container, at least a part of a

projection area of said discharge opening is sandwiched between projection areas of said two projections.

34. A toner cartridge according to any one of Claims 30 - 32, wherein as
5 said two projections and said discharge opening are projected onto an imaginary line extending in a longitudinal direction of said container, an entirety of a projection area of said discharge opening is sandwiched between projection areas of said two projections.

10 35. A toner cartridge according to any one of Claims 25 - 34, further comprising a drive input gear for receiving a driving force from the receiving apparatus.

36. A toner cartridge according to Claim 35, wherein the trailing end of
15 said open/close member approaches to said drive input gear by movement of said open/close member from the closing position to the opening position.

37. A toner cartridge according to Claim 35 or 36, further comprising a
20 feeding member for feeding the toner toward the discharge opening by the driving force received by said drive input gear.

38. A toner cartridge according to Claim 37, further comprising a
transmission gear for transmitting the driving force from said drive input gear toward said feeding member.

25

39. A toner cartridge according to any one of Claims 25 - 38, wherein said open/close member extends from the leading end portion to the trailing end

portion in a range of not less than 230° and not more than 270 ° of a circumference of said container, as said toner cartridge is seen in the longitudinal direction of said container.

5 40. A toner supply mechanism comprising said receiving apparatus and the toner cartridge according to any one of Claims 25 - 39.

 41. A toner cartridge comprising:

 (1) a container including (1 - 1) an accommodating portion for accommodating
10 toner, and (1 - 2) a discharge opening for discharging the toner from said
accommodating portion;
 (2) an open/close member movable relative to said container between a closing
position for causing said closing portion to close said discharge opening and an
opening position for causing said closing portion to open said discharge opening,
15 wherein said open/close member including a leading end portion and a trailing
end portion which are on downstream and upstream sides of said open/close
member with respect to a closing direction in which said open/close member
moves to close said discharge opening, respectively, and wherein said open/close
member extends from the leading end portion to the trailing end portion in a
20 range exceeding 180° of a circumference of said container, as said toner cartridge
is seen in the longitudinal direction of said container,

 wherein said open/close member is provided with an engaging portion
adjacent to the trailing end.

25

 42. A toner cartridge according to Claim 41, wherein said open/close
member is movable between the closing position and the opening position by

rotating around a circumference of said container.

43. A toner cartridge according to Claim 41 or 42, wherein said container has a substantially cylindrical shape.

5

44. A toner cartridge according to any one of Claims 41 - 43, wherein said open/close member is provided with an extended portion extending from said closing portion toward an upstream in the closing direction, and wherein said engaging portion is provided on said open/close member.

10

45. A toner cartridge according to Claim 44, wherein said open/close member is provided with a plurality of such said extended portions each of which is provided with said engaging portion.

15

46. A toner cartridge according to any one of Claims 41 - 45, wherein said engaging portion is provided with a projection projecting in a direction away from said container.

20

47. A toner cartridge according to any one of Claims 41 - 46, wherein said open/close member is provided with a second engaging portion adjacent to the leading end portion.

25

48. A toner cartridge according to Claim 47, wherein said second engaging portion includes a projection projecting in a direction away from said container.

49. A toner cartridge according to any one of Claims 41 - 48, wherein said container is provided with two projections arranged along a longitudinal direction

of said container, and wherein when said open/close member moves from the opening position to the closing position, the leading end portion approaches to said two projections.

50. A toner cartridge according to any one of Claims 41 - 49, wherein as
5 said two projections and said discharge opening onto an imaginary line extending in the longitudinal direction of said container, at least a part of a projection area of said discharge opening is between projection areas of said two projections.

51. A toner cartridge according to any one of Claims 41 - 50, wherein as
10 said two projections and said discharge opening onto an imaginary line extending in the longitudinal direction of said container, an entirety of a projection area of said discharge opening is between projection areas of said two projections.

52. A toner cartridge according to any one of Claims 41 - 51, further
15 comprising a drive input gear for receiving a driving force.

53. A toner cartridge according to Claim 52, wherein said engaging
portion approaches to an axis of said drive input gear by movement of said
open/close member from the closing position to the opening position.

20

54. A toner cartridge according to Claim 52 or 53, further comprising a
feeding member for feeding the toner toward the discharge opening by the
driving force received by said drive input gear.

25 55. A toner cartridge according to any one of Claims 52 - 54, further
comprising a transmission gear for transmitting the driving force from said drive
input gear toward said feeding member.

56. A toner cartridge according to any one of Claims 41 - 55, wherein said open/close member extends from the leading end portion to the trailing end portion in a range of not less than 230° and not more than 270° of a
- 5 circumference of said container, as said toner cartridge is seen in the longitudinal direction of said container.

INTERNATIONAL SEARCH REPORT

International application No.

PCT/JP2017/036049

A. CLASSIFICATION OF SUBJECT MATTER

Int.Cl. G03G15/08 (2006.01) i, G03G21/16 (2006.01) i

According to International Patent Classification (IPC) or to both national classification and IPC

B. FIELDS SEARCHED

Minimum documentation searched (classification system followed by classification symbols)

Int.Cl. G03G15/08, G03G21/16

Documentation searched other than minimum documentation to the extent that such documents are included in the fields searched

Published examined utility model applications of Japan 1922-1996

Published unexamined utility model applications of Japan 1971-2017

Registered utility model specifications of Japan 1996-2017

Published registered utility model applications of Japan 1994-2017

Electronic data base consulted during the international search (name of data base and, where practicable, search terms used)

C. DOCUMENTS CONSIDERED TO BE RELEVANT

Category*	Citation of document, with indication, where appropriate, of the relevant passages	Relevant to claim No.
Y A	JP 2001-005272 A (CANON INC.) 12 January 2001, paragraphs [0020]-[0065], fig. 15 (Family: none)	1-6, 8-9, 13-15, 17-22, 24-28, 30-31, 33-38, 40-45, 47, 49-55 7, 10-12, 16, 23, 29, 32, 39, 46, 48, 56

Further documents are listed in the continuation of Box C.

See patent family annex.

- | | |
|---|--|
| * Special categories of cited documents: | "T" later document published after the international filing date or priority date and not in conflict with the application but cited to understand the principle or theory underlying the invention |
| "A" document defining the general state of the art which is not considered to be of particular relevance | "X" document of particular relevance; the claimed invention cannot be considered novel or cannot be considered to involve an inventive step when the document is taken alone |
| "E" earlier application or patent but published on or after the international filing date | "Y" document of particular relevance; the claimed invention cannot be considered to involve an inventive step when the document is combined with one or more other such documents, such combination being obvious to a person skilled in the art |
| "L" document which may throw doubts on priority claim(s) or which is cited to establish the publication date of another citation or other special reason (as specified) | "&" document member of the same patent family |
| "O" document referring to an oral disclosure, use, exhibition or other means | |
| "P" document published prior to the international filing date but later than the priority date claimed | |

Date of the actual completion of the international search
28 November 2017

Date of mailing of the international search report
12 December 2017

Name and mailing address of the ISA/
Japan Patent Office
3-4-3, Kasumigaseki, Chiyoda-ku,
Tokyo 100-8915, Japan

Authorized officer

Telephone No.

INTERNATIONAL SEARCH REPORT

International application No.

PCT/JP2017/036049

C (Continuation). DOCUMENTS CONSIDERED TO BE RELEVANT

Category*	Citation of document, with indication, where appropriate, of the relevant passages	Relevant to claim No.
Y A	JP 2005-107392 A (SHARP CORPORATION) 21 April 2005, paragraphs [0025]-[0036], fig. 3 (Family: none)	1-6, 8-9, 13-15, 17-22, 24-28, 30-31, 33-38, 40-45, 47, 49-55 7, 10-12, 16, 23, 29, 32, 39, 46, 48, 56
Y A	JP 2005-173568 A (CANON INC.) 30 June 2005, paragraphs [0032]-[0086], fig. 2-8 & US 2005/0135841 A1, paragraphs [0039]-[0093], fig. 2-8 & US 2008/0013988 A1 & EP 1533664 A1 & KR 10-2005-0048530 A & CN 1619431 A	1-6, 8-9, 13-15, 17-22, 24-28, 30-31, 33-38, 40-45, 47, 49-55 7, 10-12, 16, 23, 29, 32, 39, 46, 48, 56
Y A	JP 2009-175759 A (CANON INC.) 06 August 2009, paragraphs [0060]-[0068], fig. 3 & US 2009/0129813 A1, paragraphs [0092]-[0100], fig. 3 & WO 2006/093361 A1 & EP 2645177 A1 & KR 10-2007-0106749 A & CN 101080677 A	20-22, 36-38, 53-55 1-19, 23-35, 39-52, 56
A	US 5548384 A (INTERNATIONAL COMMUNICATIONS MATERIALS, INC.) 20 August 1996, entire text & EP 736819 A1 & CA 2173294 A	1-56