

(19)
(12)

(KR)
(A)

(51) 。 Int. Cl.7
G02B 27/18

(11)
(43)

10-2004-0082917
2004 09 30

(21) 10-2003-0029753
(22) 2003 05 12

(30) 60/455,854 2003 03 20 (US)

(71) 416

(72) 103 106

973-3 824 706

152-42

605 1105

(74)

:

(54)

, .
, ; 1
; 2
;
;
) (

1

2

3a 3b

3c

3d

4

5a 4

5b 4

6

7

8a

8b

8c

< >

70... , 71,74...

72,73... , 72a,73a...

75... , 77...

80,130... , 85...

109,112,122,139... , 113,134,143...

114,135,142... , 127...

L₁,L₂,L₃ ...

on-off
 3
 R,G,B
 3
 가 1/3
 R,G,B
 3 1/3
 가 R,G,B
 R,G,B 가 가
 1 (100) 1 2
 G,B (102)(104) (105) 1 4 (109) (109)(112)(139)(141) R,
 1 (L₁) (R) (G) (B) 2 (L₂) (R) (G) 1 (L₁)
 2) (R) (G) 1 2 (L₁) (112) (G) 3 (L₃) (11
 1 3 (L₁)(L₂)(L₃) 가 (114)(135)(142)
 (100) (R), (G), (B) 가 1
 3 (114)(135)(142) R,G,B 가 3
 (141) R,G,B 3 (139) (127) (130) 4
 (130)
 (105) (107)가 1 3 (L₁)(L₂)(L₃)
 (110)(117)(131)(137)(145) , 1 (112) 4
 (141) 3 (139) 4 (141) (120)(140)가
 , 4 (141) (127) (124) (125)가
 , 1 (L1) 3 (L3)
 , (118)(133)가
 , 1 3 (114)(135)(142) R,G,B 가 2
 (130) 가 (114)(135)(142) R,G,B 가
 (130) ()
 , 1, 2 3 (114)(135)(142) 1, 2 3 (113)(134)(143)
 1 3 (113)(134)(143) 3a 가 (P)
 (K)가 3b 가
 3c (130) (130) 가 가 1 2 (102
)(104) 가 (100) 가 (square)
 1 3 (L₁)(L₂)(L₃) ,

3)(134)(143) 1 3 (113)(134)(143) . 1 3 (11
가

1 3 (113)(134)(143) (113)(134)(143)
(D) 3d , 1 3 (113)(134)(143)
(D) , (113)(134)(143)

1
2

1 ;
2 ;

2

1 ; 1

2
2

1 2

1 2

1 ;

2 1

2 ;
2 ;

1 ;
1 ;

1
2

3 1
2

가

가

1

가

가 ;

가
1

2

;

2

1

;

;

2

1

2

1

;

72a) 1 2 (72), 1 2 (70), (72) (73) (73c) (72)(73) (72a)(73a)

74)가 (70) 1 2 (72) 2 4 (74) (72) 1 2 (73) 2 (71)가 (73) 2 (73)가 (75)

4 (x-z) (x-y)

5a) (70) 1 (71) x-z (72) 2 (73) (74) (72a) (73a) z (z)

5b) (70) 1 (71) 1 (72) (73) 2 (74) 2 (75) (73) 2 (74)

71)(74) 1 2 (x) (72)(73) (z) (72a)(73a) 1 2 (72a)(73a)

(80) 가 5a z

(70) 2 (74) (75) (70) (77) 6 (77) (77) (73) (77) 2 P 1/2 S

(77)

(80) LC

D LCOS

7

(85), (85)

(80)

(85) (70), (70) 1 2
(72)(73) (75) (70) 1 (72)

(73) 1 2 (71)가 1 (72) 2 (74)가
(73) 2 (75) (73) 2 (74)

(77)가

(85)

(85)

(85)

(85)

9) 1 2, 3 1 2 (109), 1 (112) (10)

) (L₂), 3 1 3 (L₃) 1 (L₁), 2 (L₁)(L₂)(L₃)
가 1 (114), 2 (135) 3 (142) 3

1 2 (109)(112) (80) (109)(112)
(80) 1 2 (80)

가 1 3

(L₂) 2 1 (L₁) 1 1 (118), 2
2 2 3 (L₃) (133) 3 3 2 (L₂) (13
9) 1 3 4 (141)가

1 3 (L₁)(L₂)(L₃) (110)(117)(131)(137)(145)
, 1 1 (118) 4 (141) 3 (139) 4 (141) (

141) 1 1 (120) 2 (140)가 , 4 (141)
(127)가 3 (127) 4 (141) 3 (124)
) (125)가 (127)

, 1 (114) 1 (113), 2 (135) 2 (134), 3 (142) 3
(143) 1 3 (113)(134)(143) 1 3

, 1 2 (109)(112)

(85)

8a (113)(134)(143) 1 3 (113)(134)(143)
E

8b (G) (H) (113)(134)(143) (G)
() (H) (H)

1 3 (113)(134)(143) (w) (80)

1 3 (113)(134)(143) (80)

(80)
(80)

가 8c
)

가
(113)(134)(143)

(80)

(70)

(70)

(70)

가

(70)

1

(71)

1
2

(72)
(73)

(72a)

(74)

5a

1 2
(72a)(73a)
(72a)(73a)

(72)(73)

(72a)(73a)

(z)
(y)

, z
, 2 (74)
(72a)(73a)

(75)
(y)

1

(72)

2

(73)

2

(73)

2

(74)가

1

(72)

(113)(134)(143)

1 3 (114)(134)(143)

(80)

(80)

()

()

(57)

1.

;

1 ;

1 2 ;

2 ;

2.

1 ,

1 ;

1 2 2 ;

3.

1 2 ,

1 2 1 2

4.

1 2 ,

1 가

5.

;

1 ;

1 2 ;

2 ;

6.

5 ,

1 ;

1 2 2 ;

7.

5 6 , ,

1 , 1 ;

1 2 3 2 ;

8.

5 6 , ,
가 가 ,

9.

5 6 ,

10.

5 6 ,

1 2

11.

5 6 ,

12.

5 6 ,

1 가

13.

,
,
,
가 ;
;

14.

13 , 가 ,
, 1
;

1 2 ;

2 ;

15.

14 ,

1 1 ;

2 2 ;

16.

13 15 , ,

1 , 1 ;

1 2 3 2 ;

17.

13 15 ,

, 1 3 가 가 1 3

18.

13 15 ,

19.

13 15 ,

1 2

20.

13 15 ,

1 가

1

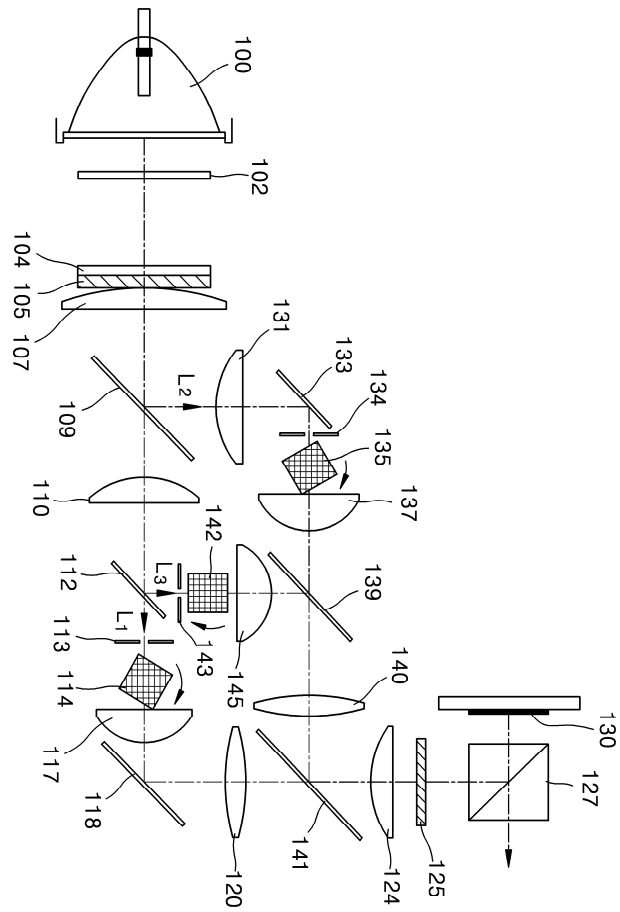

2

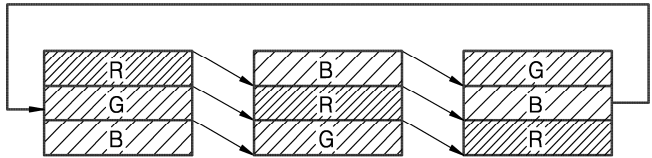

3a

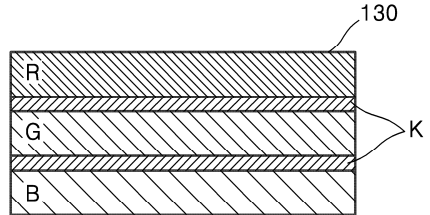

3b

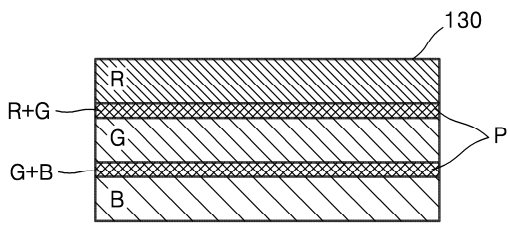

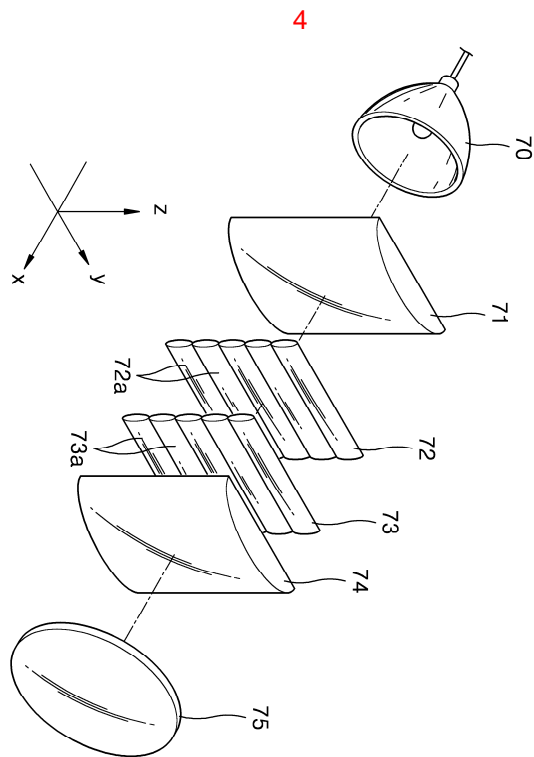
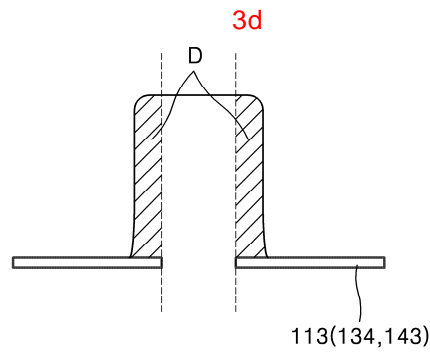
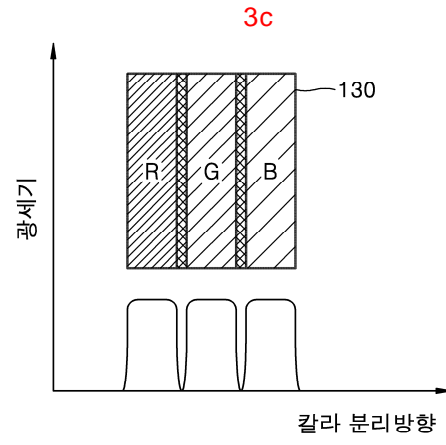

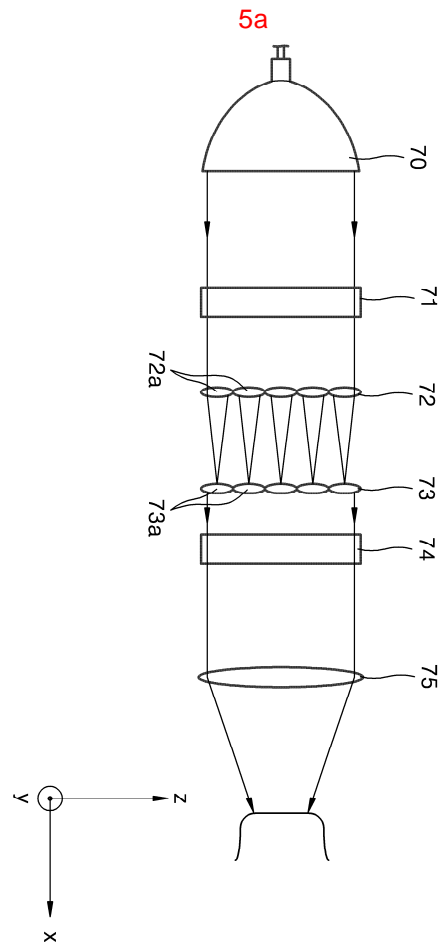

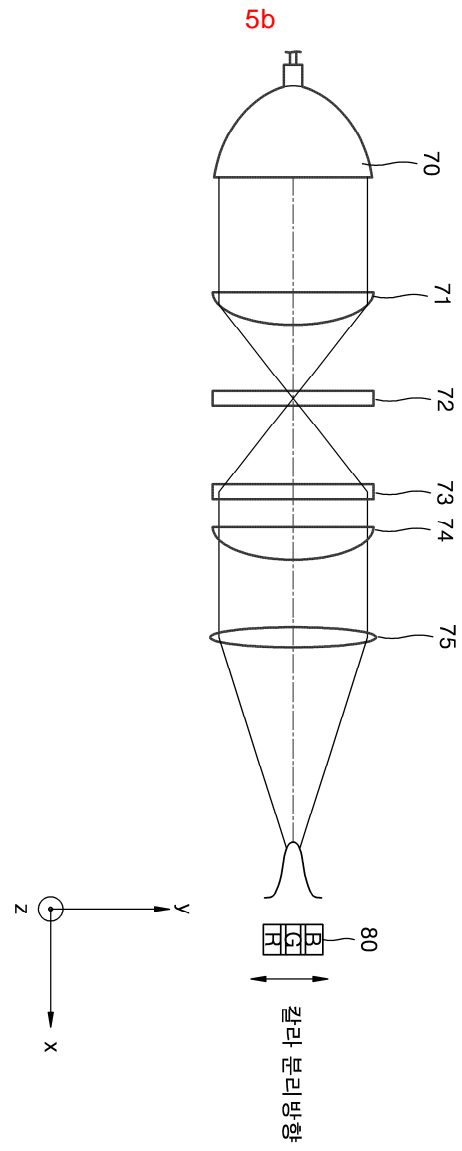

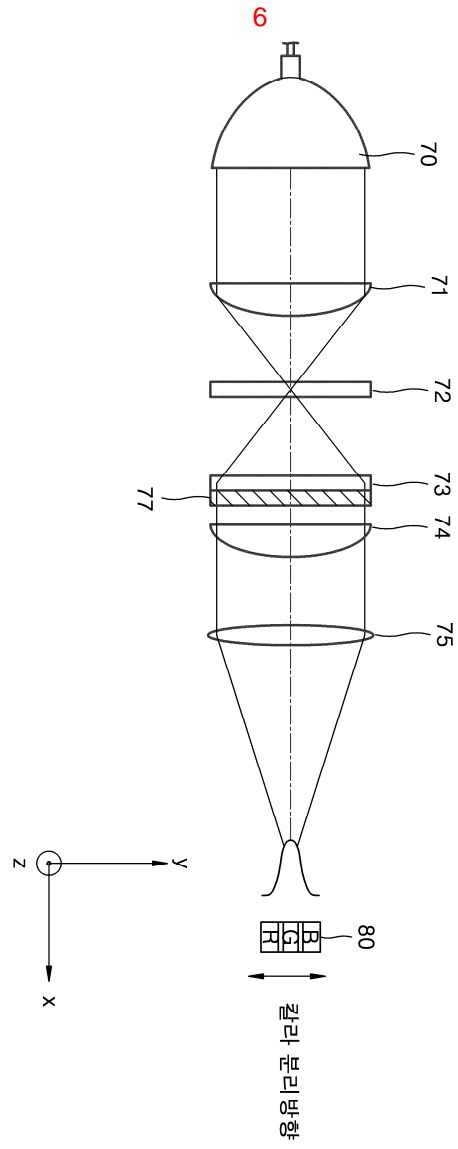

7

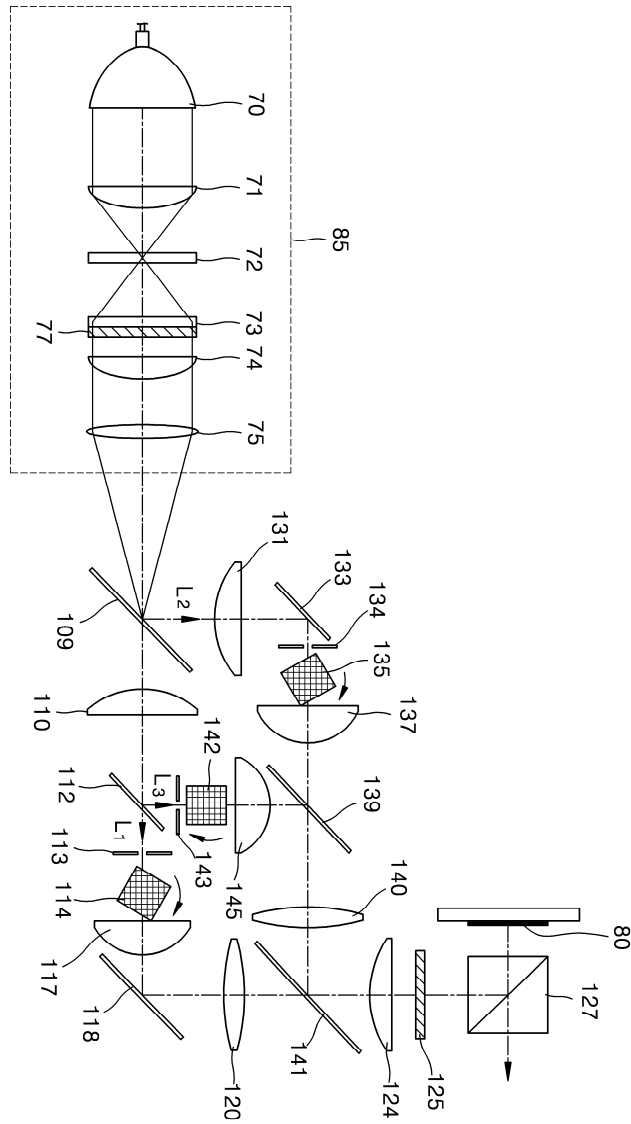

8a

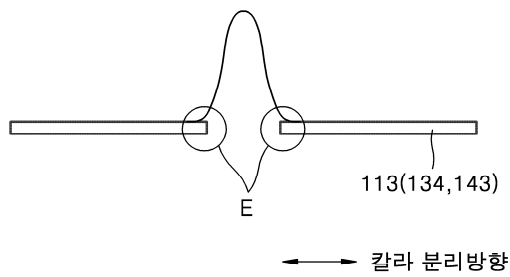

8b

