

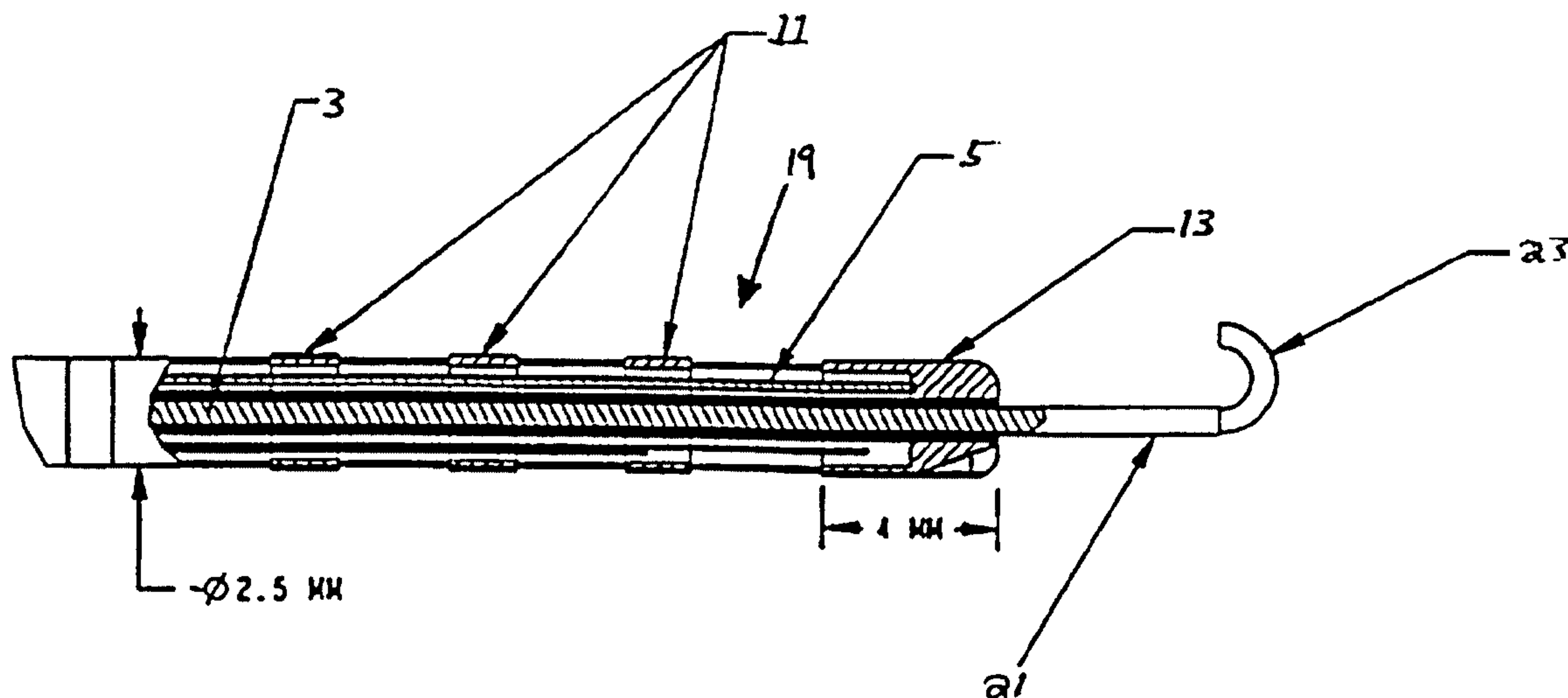

(86) Date de dépôt PCT/PCT Filing Date: 1999/11/04
 (87) Date publication PCT/PCT Publication Date: 2000/05/11
 (85) Entrée phase nationale/National Entry: 2001/05/02
 (86) N° demande PCT/PCT Application No.: US 99/25858
 (87) N° publication PCT/PCT Publication No.: WO 00/25672
 (30) Priorités/Priorities: 1998/11/04 (60/106,965) US;
 1999/10/29 (09/428,990) US

(51) Cl.Int.⁷/Int.Cl.⁷ A61B 5/055
 (71) Demandeur/Applicant:
 THE JOHNS HOPKINS UNIVERSITY, US
 (72) Inventeurs/Inventors:
 LIMA, JOAO, US;
 CALKINS, HUGH, US;
 HALPERIN, HENRY R., US;
 LARDO, ALBERT, US;
 MCVEIGH, ELLIOT R., US;
 ATALAR, ERGIN, US;
 BERGER, RONALD D., US
 (74) Agent: SMART & BIGGAR

(54) Titre : SYSTEME ET TECHNIQUE PERMETTANT D'EXECUTER DES PROCEDURES D'ABLATION ET D'ELECTROPHYSIOLOGIE GUIDÉES PAR RESONANCE MAGNETIQUE
 (54) Title: SYSTEM AND METHOD FOR MAGNETIC-RESONANCE-GUIDED ELECTROPHYSIOLOGIC AND ABLATION PROCEDURES



(57) Abrégé/Abstract:
 A system, and method for using magnetic resonance imaging to increase the accuracy of electro-physiologic procedures is disclosed. The system in its preferred embodiment provides an invasive combined electro-physiologic, an imaging antenna catheter (1) which includes an RF antenna (3) for receiving MR signals, and diagnostic electrodes (11) for receiving electrical potentials. The combined electrophysiology, and imaging antenna catheter (1) is used in combination with an MR imaging scanner to guide, to provide visualization during electro-physiologic diagnostic or therapeutic procedures.

PCTWORLD INTELLECTUAL PROPERTY ORGANIZATION
International Bureau

INTERNATIONAL APPLICATION PUBLISHED UNDER THE PATENT COOPERATION TREATY (PCT)

(51) International Patent Classification ⁷ : A61B 5/055	A1	(11) International Publication Number: WO 00/25672
		(43) International Publication Date: 11 May 2000 (11.05.00)

(21) International Application Number: PCT/US99/25858

(22) International Filing Date: 4 November 1999 (04.11.99)

(30) Priority Data:
 60/106,965 4 November 1998 (04.11.98) US
 Not furnished 29 October 1999 (29.10.99) US

(71) Applicant: THE JOHNS HOPKINS UNIVERSITY [US/US];
Suite 906, 111 Market Place, Baltimore, MD 21202 (US).

(72) Inventors: HALPERIN, Henry, R.; Baltimore, MD (US).
 BERGER, Ronald, D.; Baltimore, MD (US). ATALAR,
 Ergin; Baltimore, MD (US). MCVEIGH, Elliot, R.;
 Baltimore, MD (US). LARDO, Albert; Baltimore, MD
 (US). CALKINS, Hugh; Baltimore, MD (US). LIMA, Joao;
 Baltimore, MD (US).

(74) Agent: KURTZ, Richard, E.; Greenberg Traurig, 12th floor,
1750 Tysons Boulevard, McLean, VA 22102 (US).

(81) Designated States: AL, AM, AT, AU, AZ, BA, BB, BG, BR,
 BY, CA, CH, CN, CU, CZ, DE, DK, EE, ES, FI, GB, GD,
 GE, GH, GM, HR, HU, ID, IL, IN, IS, JP, KE, KG, KP,
 KR, KZ, LC, LK, LR, LS, LT, LU, LV, MD, MG, MK,
 MN, MW, MX, NO, NZ, PL, PT, RO, RU, SD, SE, SG,
 SI, SK, SL, TJ, TM, TR, TT, UA, UG, UZ, VN, YU, ZW,
 ARIPO patent (GH, GM, KE, LS, MW, SD, SL, SZ, TZ,
 UG, ZW), Eurasian patent (AM, AZ, BY, KG, KZ, MD,
 RU, TJ, TM), European patent (AT, BE, CH, CY, DE, DK,
 ES, FI, FR, GB, GR, IE, IT, LU, MC, NL, PT, SE), OAPI
 patent (BF, BJ, CF, CG, CI, CM, GA, GN, GW, ML, MR,
 NE, SN, TD, TG).

Published

*With international search report.
 Before the expiration of the time limit for amending the
 claims and to be republished in the event of the receipt of
 amendments.*

(54) Title: SYSTEM AND METHOD FOR MAGNETIC-RESONANCE-GUIDED ELECTROPHYSIOLOGIC AND ABLATION PROCEDURES

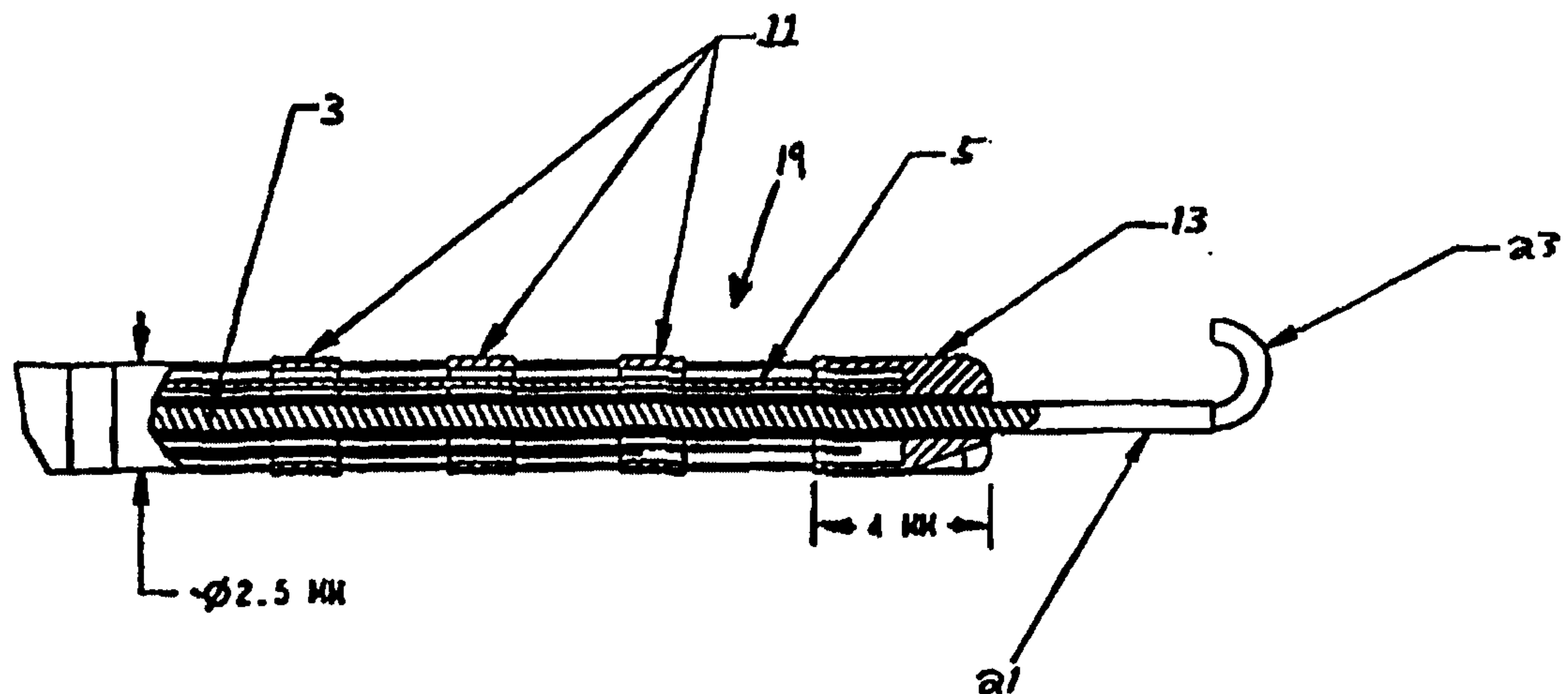
**(57) Abstract**

A system, and method for using magnetic resonance imaging to increase the accuracy of electro-physiologic procedures is disclosed. The system in its preferred embodiment provides an invasive combined electro-physiologic, an imaging antenna catheter (1) which includes an RF antenna (3) for receiving MR signals, and diagnostic electrodes (11) for receiving electrical potentials. The combined electrophysiology, and imaging antenna catheter (1) is used in combination with an MR imaging scanner to guide, to provide visualization during electro-physiologic diagnostic or therapeutic procedures.

SYSTEM AND METHOD FOR MAGNETIC-RESONANCE-GUIDED ELECTROPHYSIOLOGIC AND ABLATION PROCEDURES

5 This application claims the benefit of U.S. Provisional Patent Application No. 60/106,965 filed November 4, 1998, the entire disclosure of which is incorporated herein by reference.

BACKGROUND OF THE INVENTION

10

1. Field of the Invention

 The invention relates in general to ablation and electrophysiologic diagnostic and therapeutic procedures, and in particular to systems and methods for guiding and providing visualization during such procedures.

15

2. Related Art

 Atrial fibrillation and ventricular tachyarrhythmias occurring in patients with structurally abnormal hearts are of great concern in contemporary cardiology. They represent the most frequently encountered tachycardias, account for the most morbidity and mortality, and, despite much progress, remain therapeutic challenges.

20

 Atrial fibrillation affects a larger population than ventricular tachyarrhythmias, with a prevalence of approximately 0.5% in patients 50-59 years old, incrementing to 8.8% in patents in their 80's. Framingham data indicate that the age-adjusted prevalence has increased substantially over the last 30 years, with over-2 million people in the United States affected. Atrial fibrillation usually accompanies disorders such as coronary heart disease, cardiomyopathies, and the postoperative state, but occurs in the

25

WO 00/25672

PCT/US99/25858

absence of any recognized abnormality in 10% of cases. Although it may not carry the inherent lethality of a ventricular tachyarrhythmia, it does have a mortality twice that of control subjects. Symptoms which occur during atrial fibrillation result from the often rapid irregular heart rate and the loss of atrio-ventricular (AV) synchrony. These symptoms, side effects of drugs, and most importantly, thromboembolic complications in the brain (leading to approximately 75,000 strokes per year), make atrial fibrillation a formidable challenge.

Two strategies have been used for medically managing patients with atrial fibrillations. The first involves rate control and anticoagulation, and the second involves attempts to restore and maintain sinus rhythm. The optimal approach is uncertain. In the majority of patients, attempts are made to restore sinus rhythm with electrical or pharmacologic cardioversion. Current data suggest anticoagulation is needed for 3 to 4 weeks prior to and 2 to 4 weeks following cardioversion to prevent embolization associated with the cardioversion. It remains controversial whether chronic antiarrhythmic therapy should be used once sinus rhythm is restored. Overall, pharmacologic therapy is successful in maintaining sinus rhythm in 30 to 50% of patients over one to two years of follow-up. A major disadvantage of antiarrhythmic therapy is the induction of sustained, and sometimes lethal, arrhythmias (proarrhythmia) in up to 10% of patients.

If sinus rhythm cannot be maintained, several approaches are used to control the ventricular response to atrial fibrillation. Pharmacologic agents which slow conduction through the AV node are first tried. When pharmacologic approaches to rate control fail, or result in significant side effects, ablation of the AV node, and placement of a permanent pacemaker is sometimes considered. The substantial incidence of thromboembolic strokes makes chronic anticoagulation important, but bleeding complications are not unusual, and anticoagulation cannot be used in all patients. Medical management of atrial fibrillation, therefore, is inadequate.

In addition to medical management approaches, surgical therapy of atrial fibrillation has also been performed. The surgical-maze procedure, developed by Cox, is an approach for suppressing atrial fibrillation while maintaining atrial functions.

5 This procedure involves creating multiple linear incisions in the left and right atria. These surgical incisions create lines of conduction block which compartmentalize the atrium into distinct segments that remain in communication with the sinus node. By reducing the mass of atrial tissue in each segment, a sufficient mass of atrial tissue no longer exists to sustain the multiple reentrant rotors, which are the basis for atrial

10 fibrillation. Surgical approaches to the treatment of atrial fibrillation result in an efficacy of > 95% and a low incidence of complications. Despite these encouraging results, this procedure has not gained widespread acceptance because of the long duration of recovery and risks associated with cardiac surgery.

15 Invasive studies of the electrical activities of the heart (electrophysiologic studies) have also been used in the diagnosis and therapy of arrhythmias, and many arrhythmias can be cured by selective destruction of critical electrical pathways with radio-frequency (RF) catheter ablation. Recently, electrophysiologists have attempted to replicate the maze procedure using radio-frequency catheter ablation, where healing

20 destroys myocardium. The procedure is arduous, requiring general anesthesia and procedure durations often greater than 12 hours, with exposure to x-rays for over 2 hours. Some patients have sustained cerebrovascular accidents.

One of the main limitations of the procedure is the difficulty associated with

25 creating and confirming the presence of continuous linear lesions in the atrium. If the linear lesions have gaps, then activation can pass through the gap and complete a reentrant circuit, thereby sustaining atrial fibrillation or flutter. This difficulty contributes significantly to the long procedure durations discussed above.

Creating and confirming continuous linear lesions could be facilitated by improved techniques for imaging lesions created in the atria. Such an imaging technique may allow the procedure to be based purely on anatomic findings.

5 The major technology for guiding placement of a catheter is x-ray fluoroscopy. For electrophysiologic studies and ablation, frame rates of 7-15 / sec are generally used which allows an operator to see x-ray-derived shadows of the catheters inside the body. Since x-rays traverse the body from one side to the other, all of the structures that are traversed by the x-ray beam contribute to the image. The image, therefore is a superposition of
10 shadows from the entire thickness of the body. Using one projection, therefore, it is only possible to know the position of the catheter perpendicular to the direction of the beam. In order to gain information about the position of the catheter parallel to the beam, it is necessary to use a second beam that is offset at some angle from the original beam, or to move the original beam to another angular position. Since x-ray shadows are the
15 superposition of contributions from many structures, and since the discrimination of different soft tissues is not great, it is often very difficult to determine exactly where the catheter is within the heart. In addition, the borders of the heart are generally not accurately defined, so it is generally not possible to know if the catheter has penetrated the wall of the heart.

20

Intracardiac ultrasound has been used to overcome deficiencies in identifying soft tissue structures. With ultrasound it is possible to determine exactly where the walls of the heart are with respect to a catheter and the ultrasound probe, but the ultrasound probe is mobile, so there can be doubt where the absolute position of the probe is with respect to
25 the heart. Neither x-ray fluoroscopy nor intracardiac ultrasound have the ability to accurately and reproducibly identify areas of the heart that have been ablated.

A system known as "non-fluoroscopic electroanatomic mapping (Ben-haim; US Patent #5391199), was developed to allow more accurate positioning of catheters within

the heart. That system uses weak magnetic fields and a calibrated magnetic field detector to track the location of a catheter in 3-space. The system can mark the position of a catheter, but the system relies on having the heart not moving with respect to a marker on the body. The system does not obviate the need for initial placement using x-ray
5 fluoroscopy, and cannot directly image ablated tissue.

MR is a known imaging technique which uses high-strength magnetic and electric fields to image the body. A strong static magnetic field (between the magnet poles in this example) orients the magnetic moments of the hydrogen nuclei. RF time-varying
10 magnetic field pulses change the spatial orientation of the magnetic moments of the nuclei. To exert a significant torque on the moment, the frequency of the magnetic field must be equal to the frequency of precession of the magnetic moment of the nuclei about the direction of the static magnetic field. This frequency of precession is a natural, or resonance, frequency of the system (hence Magnetic Resonance Imaging).
15 The time-varying gradient magnetic field is used for spatial encoding of the signals from the issue. The magnitude of the gradient field is a linear function of the space coordinates in the magnet. As a result of the addition of the static and gradient magnetic fields, the total local magnetic field and, thus, the local resonance frequency, becomes a linear function of position. Thus, imaging tissues in any plane can be
20 accomplished because the location of each volume element is known in three-dimensional space.

MRI is generally considered a safe technique, since no x-rays are used and the electromagnetic fields do not, by themselves, cause tissue damage.
25

While MRI may provide the visual guidance necessary for creating and confirming linear lesions, it has been assumed that electrical wires implanted in a patient can act as antennas to pick up radio-frequency energy in an MR system and conduct that energy to the patient, thereby causing tissue injury.

Magnetic resonance imaging has been used to guide procedures in which RF energy is applied to non-contractile organs such as the brain, liver and kidneys to ablate tumors. However, these systems are not suitable for use in the heart.

5

U.S. Patent No. 5,323,778 to Kandarpa et al. discloses a method and apparatus for magnetic resonance imaging and tissue heating. There is no provision in the disclosed probe for measuring electrical signals; and, it is unclear how much resolution the probe provides.

10

OBJECTS AND SUMMARY OF THE INVENTION

It is therefore an object of the invention to provide an improved system and method for guiding and/or providing visualization during electrophysiologic procedures.

It is a further object of the invention to provide a system and method for guiding or visualizing ablation procedures which is suitable for use in the heart and other structures.

20

It is a further object of the invention to provide a system and method for imaging ablation lesions with increased resolution and reliability.

25

The invention provides a system and method for using magnetic resonance imaging to increase the safety and accuracy of electrophysiologic procedures. The system in its preferred embodiment provides an invasive combined electrophysiology and imaging antenna catheter which includes an RF antenna for receiving magnetic resonance signals and diagnostic electrodes for receiving electrical potentials. The

combined electrophysiology and imaging antenna catheter is used in combination with a magnetic resonance imaging scanner to guide and provide visualization during electrophysiologic diagnostic or therapeutic procedures. The invention is particularly applicable to catheter ablation of atrial and ventricular arrhythmias. In embodiments
5 which are useful for catheter ablation, the combined electrophysiology and imaging antenna catheter may further include an ablation tip, and such embodiment may be used as an intracardiac device to both deliver energy to selected areas of tissue and visualize the resulting ablation lesions, thereby greatly simplifying production of continuous linear lesions. Additionally, the ablation electrode can be used as an active tracking
10 device that receives signal from the body coil excitation. Gradient echoes are then generated along three orthogonal axes to frequency encode the location of the coil and thus provide the three-dimensional space coordinates of the electrode tip. These numeric coordinates can then be used to control the imaging plane of the scanner, thereby allowing accurate imaging slices to be automatically prescribed though the anatomic target for RF
15 therapy. The invention further includes embodiments useful for guiding electrophysiologic diagnostic and therapeutic procedures other than ablation. Imaging of ablation lesions may be further enhanced by use of MR contrast agents. The antenna utilized in the combined electrophysiology and imaging catheter for receiving MR signals is preferably of the coaxial or "loopless" type that utilizes a helical whip.
20 High-resolution images from the antenna may be combined with low-resolution images from surface coils of the MR scanner to produce a composite image. The invention further provides a system for eliminating the pickup of RF energy in which intracardiac wires are detuned, by for example low-pass filters, so that they become very inefficient antennas. An RF filtering system is provided for suppressing the MR imaging signal
25 while not attenuating the RF ablative current. Steering means may be provided for steering the invasive catheter under MR guidance. Lastly, the invention provides a method and system for acquisition of high-density electroanatomic data using a specially designed multi-electrode catheter and the MRI scanner. This will be achieved by

using an active tracking system that allows the location of each electrode to be determined.

5

BRIEF DESCRIPTION OF THE DRAWINGS

The foregoing and other objects, features, and advantages of the invention will be apparent from the following more particular description of preferred embodiments as illustrated in the accompanying drawings, in which reference characters refer to the same parts throughout the various views. The drawings are not necessarily to scale, emphasis instead being placed upon illustrating principles of the invention.

FIG. 1 shows a schematic view of a combined electrophysiology and imaging antenna catheter in accordance with a preferred embodiment of the invention.

FIG. 2 shows a cross-sectional detail view of a tip portion of combined electrophysiology and imaging antenna catheter in accordance with a preferred embodiment of the invention.

20

FIG. 3 shows a block diagram illustrating the operation of an MRI scanner system which may be used in connection with the system and method of the invention.

FIG. 4 illustrates a schematic block diagram showing an example of radio-frequency filters which may be used in accordance with the invention.

25

FIG. 5 shows a graphic representation of electrical signals measured from a catheter in accordance with the invention during MR imaging.

FIG. 6 shows a high-level block diagram illustrating an ablation system incorporating radio-frequency filters in accordance with a preferred embodiment of the invention.

5 FIG. 7 shows three-dimensional reconstructions of MR images from planar sections.

10

DETAILED DESCRIPTION

The invention in its preferred embodiment uses MR imaging to allow catheters to be placed without radiation, and provides very accurate localization of catheter tips in 3-dimensional space. With current MRI scanners, resolution is limited by the distance the RF coil is from the volume of tissue being imaged. RF from any particular imaging volume is picked up by the surface coil. The gradients select a volume inside the body for imaging, but the coil outside the body picks up the signal from the volume. The farther the surface coil is from the imaging volume, the more noise will be present.

20

In accordance with a preferred embodiment of the invention, an intracardiac receiving coil/antenna is used so that the receiving coil/antenna is closer to the imaging volume (lesions), thereby reducing noise, increasing signal, and improving resolution where it is needed most.

25

In a first embodiment of the invention, MRI is used to facilitate catheter ablation of atrial fibrillation by guiding creation of continuous linear ablation lesions and confirming that a complete linear lesion has been created (line of block). The visualization of areas of ablation may allow a reduction in the number of lesions

needed, and may also reduce the number of recurrences, by more accurately ablating the arrhythmias.

FIGS. 1 and 2 show schematic and detail views, respectively, of a combined
5 electrophysiology and imaging antenna catheter in accordance with a preferred
embodiment of the invention. The device of the invention is used in combination with
an MRI scanner such that RF energy can be delivered to selected areas of tissue, the
tissue imaged with an invasive (e.g., intracardiac) antenna, and RF lesions or other
targets can be visualized in both high and low resolution modes. MRI allows
10 visualization of lesions in the ventricle with the use of surface coils, and in the atria
with surface coils and/or the intracardiac catheter-antenna. With these catheter
antennae, the image can be aligned perpendicular to the catheter, such that the best
resolution will be at site of the lesion. This lesion visualization can be used for (1)
precise titration of therapy, (2) the ability to test the length and depth of lesions from
15 new ablation-energy sources, and (3) accurate assessment of the success of making lines
of ablation.

In addition to catheter-antenna, high-resolution imaging can also be done with
receivers that contain loops that are placed inside the body. These loops may be fixed
20 in size or may be expandable once placed in the body to increase their surface area.

MRI can also be used in accordance with the invention to guide other procedures.
In cardiology, accurate anatomic information, combined with electrical measurements,
allows improved study of the pathophysiology of arrhythmias, stunning, remodeling,
25 and tachycardia-induced myopathy. Outside of cardiology, it has already been
demonstrated that biopsies of liver, kidney, adrenal gland, neck masses, and lymph
nodes could all be done safely and accurately with MR-guidance. With extensions of
the biopsy technique, MRI-guided ablation of tumors such as metastatic liver disease,

brain tumors, and prostate cancer, may allow treatment with less morbidity and less cost than conventional open surgery.

FIG. 1 shows a schematic diagram of the device 1 of the invention and FIG. 2 shows a detail view of a tip portion 15 of the device. The system of the invention preferably comprises a combined electrophysiology and imaging antenna catheter 1 which is used in conjunction with an MRI scanner such that visualization can be performed simultaneously with delivery of RF energy to selected areas of tissue for ablation. In embodiments designed for cardiac ablation applications, the length of the invasive portion of the device is preferably at least 1200 millimeters long so that the tip can be placed into the heart from the femoral artery or vein. The diameter of the device is approximately 2.5 mm.

The device preferably includes between one and three diagnostic electrodes 11 for receiving electrical potentials, e.g., intracardiac potentials, in connection with electrophysiological procedures and testing. In embodiments useful for ablation applications, the device further includes an ablation tip 13. The electrodes 11 are preferably fabricated from platinum or gold. The tip portion 15 of the device is deflectable by a steering wire 5, preferably of titanium construction, that is inside a low-friction sheath, preferably of Teflon construction. The steering wire 5 connects to a steering knob 7 and moves toward or away from the tip when the steering knob 7 is rotated, deflecting the tip in the appropriate direction. A connector 9 is used to interconnect the antenna 3 with receiver or scanner circuitry, which is discussed in further detail below, and is also used to connect the electrodes 11 to external electronic devices.

The device of the invention includes an antenna portion 19, which may be of various suitable designs. In the preferred embodiment, a flexible, helical whip coaxial loopless antenna is used. Such an antenna can be made by removing a section of the

shield from an antenna coaxial cable, so as to form a 'whip' with the center conductor. To avoid direct biofluid contact with conductive components of the catheter it will be covered with a non-conductive dielectric material. Addition of insulation to the antenna, however, increases the whip length required for optimal image quality to a length that prohibitively large for in vivo use. Incorporating a helical whip in the loopless antenna design overcomes this limitation by allowing up to 10 times the electrical length to be achieved in the same physical length as a straight conductor whip. In addition to these electromagnetic advantages, the helical antenna whip also improves the mechanical properties of the device and thereby greatly improve intravascular and intracardiac navigation of the catheter without kinking, folding or mechanical failure of the whip. The flexible helical whip has guidewire properties and thus reduces the risks of vascular or cardiac perforation. The length of helical whip can be varied to help in tuning the antenna to the optimal impedance and in optimizing the signal-to-noise ratio. Further details regarding the structure and design of suitable loopless antennas can be found in U.S. Patent No. 5,928,145, issued July 27, 1999, the entire disclosure of which is incorporated herein by reference.

Since loops can receive more signal in a given imaging volume, an antenna incorporating a loop may provide an improved signal-to-noise ratio, resulting in clearer images. A loop can be formed, where the antenna whip 21 is connected to the antenna body 19 via a miniature capacitor. A balloon can be incorporated into the catheter, and the loop can be attached to the surface of the balloon. When the balloon is inflated, the loop will expand.

In embodiments of the invention wherein a coaxial loopless antenna is utilized, a helical whip portion 21 of the flexible antenna protrudes from the distal tip to complete the dipole antenna. The whip portion 21 is coated with an insulating layer and its tip 23 can be exposed and formed into a "J" to help prevent the whip from perforating

internal physiological structures. The antenna whip portion 21 should be insulated from the ablation tip.

When the device of the invention is used for intracardiac ablation procedures, tissue is imaged with the antenna and RF lesions can be visualized in both high and low resolution modes. As is discussed in detail below, the images may be enhanced with MRI contrast, such as gadolinium. Software can be provided for optimally visualizing the lesions, and for allowing the operator to change viewing perspective in near-real time.

10

As is set forth above, embodiments of the invention which are useful for ablation procedures preferably include an ablation tip 13. As an alternative to the preferred embodiment wherein the active element of the antenna runs within the catheter in a coaxial fashion, the RF ablation element in the ablation tip may be designed to serve both as an RF ablation transmitter and as a receiver coil for MR imaging. In such embodiments, a switching device can be used to switch the catheter between imaging and ablation modes. When not in ablation mode, the ablation electrode, and the other electrodes on the catheter, can be used to measure electrical signals.

20

Another embodiment of the combined antenna and RF probe device is the use of untuned RF electrodes as tracking devices. Single or multiple RF electrodes may serve as small RF coils that receive signal from the body coil excitation and then are frequency encoded in three orthogonal planes. These three space numeric coordinates can then be used to automatically control the imaging plane of the scanner, allowing optimal imaging of the target region for RF therapy. Additionally, as the electrodes can also acquire bioelectric signals, electrode location data allows the generation of true electroanatomic data.

25

For most applications, the impedance of the imaging antenna must match the impedance of the input amplifier. With an ordinary 64 MHz input amplifier, this impedance is 50 Ohms. A number of matching networks are possible, the simplest being a series capacitor of an appropriate value. A network analyzer can be used to allow optimal matching of different antenna designs. o customize matching to an individual patient, the network analyzer can be automated and incorporated into the matching network to automatically tune the matching network after the antenna has been placed into the patient.

The catheter antenna device of the invention in accordance with its preferred embodiment is constructed so as to be fully MRI-compatible. Specifically, it's design and materials are selected such that (1) the image is not significantly distorted by the device; (2) the MRI electromagnetic fields do not alter the normal functioning of the device; (3) cardiac arrhythmias are not produced by the device, and (4) no damage to the tissue is produced by radio-frequency energy received from the MRI scanner. The presence of even small amounts of magnetic material in the imaging fields can produce substantial amounts of image distortion. This distortion is caused by perturbation of the imaging magnetic field. The most distortion is caused by ferromagnetic materials (iron, nickel, cobalt). Little if any distortion is produced by materials that do not become significantly magnetized (low magnetic susceptibility) by the MRI magnetic field. Metals which do not produce significant magnetization include copper, gold, platinum and aluminum. Many plastics and synthetic fibers are entirely non-magnetic and do not distort the images.

FIG. 3 shows a block diagram illustrating the operation of an MRI scanner system which may be used in connection with the system and method of the invention. A magnet is provided for creating the magnetic field necessary for inducing magnetic resonance. Within the magnet are gradient coils for producing a gradient in the static magnetic field in three orthogonal directions. Within the gradient coils is an RF coil.

The RF coil produces the magnetic field necessary to rotate the spins of the protons by 90° or 180°. The RF coil also detects the signal from the spins within the body. A computer is provided for controlling all components in the imager. The RF components under control of the computer are the RF frequency source and pulse programmer. The source produces a sine wave of the desired frequency. The pulse programmer shapes the RF pulses, and the RF amplifier increases the pulse power up to the kilo-watt range. The computer also controls the gradient pulse programmer which sets the shape and amplitude of each of the three gradient fields. The gradient amplifier increases the power of the gradient pulses to a level sufficient to drive the gradient coils.

The invention in accordance with a preferred embodiment further includes filter means and shielding for protecting electronic equipment (e.g., the MR scanner) from RF produced by the ablation system, for protecting the ablation and measuring system from RF produced by the MR scanner, and for allowing measurement of the relevant electrical signals. Without adequate radio-frequency filters, the electronics attached to the catheter may malfunction during imaging. FIG. 4 illustrates a schematic block diagram showing an example of radio-frequency filters which may be used in accordance with the invention. Low-pass filters using 1- μ henry inductors made without magnetic materials, and 220 picofarad capacitors, have optimal attenuation of the 64 Mhz radio-frequency energy present in the 1.5 Tesla MR scanner. A number of filter topologies were tested, and the two stage filter shown in FIG. 4 had the best results. A separate two-stage filter (L₁, L₃, C₁, C₃; and L₂, L₄, C₂, C₄), is preferably placed in each wire to the catheter. These filters can reduce the 15 - 32 volts of radio-frequency pickup down to a few millivolts and cause no problems with the electronics.

The output of the RF filters can be applied to a series of active filters. The active filters may comprise, e.g., a sixth order, Chebyshev (1 dB ripple), low-pass filter (50-300 Hz corner); then a second order, Chebyshev (1 dB ripple), high-pass filter (3-50

Hz corner); and then a 60 Hz notch filter. These filters limit the signal bandwidth, and substantially reduce gradient-field-induced noise-- see FIG. 5(c), discussed below. The gradient field noise was not rejected by the RF filters. This filter arrangement is used in the catheter-intracardiac electrogram measuring circuit. The circuit for ablation does not incorporate the active filters, since while the RF filtering system is designed to suppress the 64MHz imaging signal. It does not attenuate the RF ablative current, since the radio frequency of the ablation system is 200-800 kHz, and the corner for the low-pass RF filters is 1-10 MHz. The ablation circuit does not need the lower-frequency filters, since that circuit is not being used to measure electrograms.

FIG. 5 shows a graphic representation of electrical signals measured from a catheter in accordance with the invention during MR imaging. FIG. 5(a) shows the signals measured from a catheter without the use of RF filters; it can be seen that the ECG is obscured by noise (32 volts peak-to-peak). FIG. 5(b) shows such signals wherein RF filters are used; it can be seen that nearly all radio-frequency interference is removed and an ECG signal is now apparent. The pairs of vertical lines are artifacts from the gradient fields. FIG. 5(c) shows such signals wherein active RF filters are used; it can be seen that most of the gradient artifact is also suppressed.

FIG. 6 shows a high-level block diagram illustrating an ablation system incorporating the filters described above. The RF Generator may comprise, e.g., a standard clinically approved ablation unit, such as those commercially available from Medtronic, having an RF output frequency of $482.6 \pm 5\text{kHz}$ and an output of 50W into a 50-250 Ω load. The output frequency from the RF generator is directed to the ablation catheter through two filter assemblies (low pass, 2Mhz corner). Both filter assemblies are fully shielded and are connected by fully shielded cable. The ECG amplifiers incorporate the active filters as described above. The dispersive ground electrode consists of a large conductive-adhesive pad that is attached to the skin of the animal to complete the circuit. The defibrillator (identified as "defib" in FIG. 8) may comprise a standard defibrillator used in ablation procedures.

It is important that the location of the tip of the catheter can be accurately determined. A number of modes of localization can be used. Because the catheter is a receiver it can be used to directly image the tissue around it. This image can be viewed
5 on its own at high resolution, or, it can be viewed at low resolution as an overlay on a large field-of-view "scout" image obtained with an auxiliary coil outside the body. The location of the catheter in the body can be tracked by the bright line of signal moving in the scout image. The scout image can be updated at an interval set by the user to compensate for patient motion. An interactive control will allow the physician to
10 "zoom in" towards the bright catheter, finally resulting in a high resolution image around the catheter tip. The "zoom" function can be achieved with interactive control of the imaging gradients.

A composite "medium resolution" resolution image can be used to construct a
15 three-dimensional map of the areas in the heart that have undergone ablation. These areas will be marked by elevated T2 values, or decreased T1 values during Gd infusion. A composite three-dimensional rendering of the heart can be updated after each ablation and displayed with an appropriate rendering technique.

20 The guidance of the catheter tip to the next site of ablation, or to fill in a previous ablation line can be assisted using the MR images. This assistance can be entirely passive, in that the physician uses the images to manipulate the catheter, or automatic tracking and feedback could assist that physician to steer the catheter.

25 The lesions may be visualized using standard imaging techniques. It may be necessary to MR contrast to enhance the lesions to allow adequate visualization to occur. One such enhancement method uses gadolinium-DTPA, but other suitable contrast agent could be used. The rationale underlying the utilization of gadolinium-DTPA based contrast agents to enhance signal intensity in atrial or ventricular

myocardium injured by RF during therapeutic ablation is based on the following observations: 1) Gadolinium-DTPA exerts its signal enhancing effect by interacting with water protons and inducing a shorter relaxation time in response to any given radio-frequency stimulus. This effect creates the image contrast necessary to allow
5 distinction in relation to regions unaffected by contrast. 2) Gadolinium-DTPA is a large molecule which cannot penetrate the uninjured cell membrane and is therefore restricted to the extracellular space in uninjured myocardium. After the RF burn, the injured membrane allows penetration of the contrast agent thus increasing significantly the volume of distribution for the contrast agent and resulting in a 'brighter' voxel of
10 tissue on T1 weighted images. 3) This difference in voxel content of water protons potentially exposed to the gadolinium-DTPA molecule creates the possibility of distinguishing injured from non-injured tissue with greater spatial resolution than in non-enhanced images.

15 Gadolinium-DTPA can be injected prior to the RF ablation protocol to enhance injured myocardium as the lesions are produced. The agent takes 5-10 minutes to equilibrate between extracellular and intracellular spaces and a few hours to be eliminated through the kidneys. The agent is routinely used in brain MRI studies to highlight areas of inflammation and in cardiac MR studies to delineate myocardial
20 regions injured by prolonged ischemia. Gadolinium-DTPA has an appropriate safety profile and except for occasional nausea, does not cause side effects leading to discomfort or complications in patients.

Imaging of ablated lesions may be further enhanced by use of thermal imaging
25 techniques. Thermal imaging can be accomplished by using phase differences in MR signals.

Three-dimensional image reconstruction can be performed using the system and method of the invention. FIG. 7 shows three-dimensional reconstructions of MR

images from planar sections. In particular, FIG. 7 shows three-dimensional reconstructions of images during activation of the left ventricle from a right ventricular pacing site. In FIG. 7, the white areas show the spread of mechanical activation as the wave of electrical activation spreads across the left ventricle from the right ventricular
5 pacing site. Similar image processing techniques can be used for visualizing ablated areas.

The advantages of the system and method for MR-guided electrophysiology in accordance with the invention will now be discussed in further detail.

10

Recent advances in MRI technology enable frame rates higher than 10/sec. This exceeds the frame rate often used in current pulsed x-ray fluoroscopy systems. When the depth dimension of the MRI slice is set as large as the body depth, the resulting 2-dimensional image sequence can serve as an effective substitute for x-ray fluoroscopy.
15 The system can thus facilitate catheter placement for EP study with real-time imaging, without the need for ionizing radiation. Catheters used in this system must be composed entirely of non-ferromagnetic materials, so as not to perturb the electromagnetic gradient field required for distortion-free MR imaging.

20

MRI allows for precise localization of object elements in three-dimensional space. Catheter tip position within the heart can thus be determined accurately and precisely, and can then be displayed superimposed on anatomically accurate reconstructions of cardiac architecture. This functionality is not possible with x-ray
fluoroscopy.

25

Electrical activation timing information obtained via an EP mapping catheter, when combined with catheter localization information, enables accurate color-coded activation maps. This capability is most useful in determining the site of origin of an atrial or ventricular tachycardia.

Activation maps can be superimposed on anatomically accurate reconstructions of cardiac structure. Spatially accurate voltage data, however, requires knowledge of the location of each electrode in contact with the myocardium. This can be achieved by using
5 high-density basket catheter electrodes in conjunction with active tracking RF coils. Each untuned electrode is capable of receiving signal, which in turn, provides the 3-space coordinates of each electrode. Electrical data originating from each known electrode position allows generation of activation and voltage maps on true anatomic structures. This provides significant advantages beyond the capabilities of the non-fluoroscopic
10 electroanatomic mapping system noted above, since that system does not provide accurate anatomic information, again without additional hardware.

An imaging antenna can be incorporated into a steerable mapping/ablation catheter, enabling high-resolution imaging in the region near the catheter tip. The
15 image obtained with this antenna has a similar radius of view as that with intracardiac ultrasound, but with far greater resolution. Furthermore, this high-resolution image is obtained without the need for placement of an additional catheter, as is required with intracardiac ultrasound.

20 High-resolution images derived from the internal antenna can be combined with lower-resolution wide-field images obtained with the external coil into a single image. This composite image will display the entire cardiac cross section with enhanced resolution in the area of greatest interest

25 When the ablation/imaging catheter is used for the delivery of ablative radio-frequency energy, the high-resolution image obtained via this catheter enables visualization of the lesion and of lesion growth. It may also be possible to visualize lesions with surface coils alone, if the tissue is thick enough.

Directional orientation, as well as location, of the catheter tip can be determined in three-dimensional space. The high-resolution image data obtained via the internal antenna can be displayed in any plane, and in particular, in the plane orthogonal to the catheter. Since the image is obtained with the same catheter that is delivering the ablative energy, the orthogonal-plane image is guaranteed to display the lesion at its maximal radius, without the need to manipulate a second (imaging) catheter into alignment with the ablation catheter. Lesion size will thus not be underestimated as often occurs with intracardiac ultrasound. In the latter case, the imaging catheter differs from the ablation catheter. It is therefore not necessarily imaging at the same level as the ablation catheter tip, and is not necessarily parallel to the ablation catheter so the image plane is oblique to the lesion equator.

MR is an imaging modality that can be tuned to characterize tissue physiology as well as structure. This enables imaging of lesions by virtue of changes in structure and cell function that occur with fulguration. Injection of gadolinium further enhances the MR image contrast between healthy and ablated myocardium. Intracardiac ultrasound, on the other hand, enables visualization of lesions only to the extent that tissue echogenicity is altered.

Because the MRI-guided EP system of the invention combines two-dimensional real-time image sequences, accurate three-dimensional catheter tip localization for activation mapping, and the ability to "see" myocardial tissue and lesion growth, it offers the best features of x-ray fluoroscopy, the non-fluoroscopic electroanatomic mapping system, and intracardiac ultrasound all at once without ionizing radiation, extra venipunctures, or excessively expensive catheters.

High-resolution visualization of ablative lesions by the internal MR antenna allows for documentation of whether or not RF application resulted in successful lesion

development and of where lesions have and have not yet been made. This facilitates efficient catheter placement so that RF is applied only to tissue not previously ablated.

5 The high-resolution images obtained with the internal MR antenna enables visualization of the relatively thin atrial wall. This structure may not be well visualized by the external MR coil due to lack of adequate resolution. If the atrial wall or other anatomical structures to be visualized have thick enough walls, which does occur, adequate visualization may be obtained with surface coils alone.

10

The combination of the high-resolution visualization and images discussed above makes high-resolution MRI guidance ideal for visualization and verification of ablative lesion lines, particularly in atrial tissue. This is useful for ablation of the reentrant circuit in typical atrial flutter and is crucial for successful ablation of atrial fibrillation.

15 Investigators have shown that atrial fibrillation can be eliminated with multiple lines of ablative lesions placed in the right and left atria to emulate the surgical maze procedure. Failures of the 'percutaneous maze' procedure have resulted primarily from incomplete lesion lines. MRI guidance should allow rapid confirmation of lesion line continuity and avoidance of unnecessary repetition of RF application where tissue has
20 already been successfully ablated.

The MRI-guided catheter ablation system offers advantages in ablation of ischemic and idiopathic ventricular tachycardias, ectopic atrial tachycardias, atrial flutter, and atrial fibrillation. Unlike AV node reentry and accessory pathway mediated
25 tachycardia, these other arrhythmias have lower ablation success rates and longer ablation procedure durations, primarily due to difficulties in accurate activation mapping or confirmation of lesion development with conventional equipment. Procedure durations and risk of complications should thus be reduced substantially with the MRI-guided catheter ablation system.

WO 00/25672**PCT/US99/25858**

While the invention has been particularly shown and described with reference to a preferred embodiment thereof, it will be understood by those skilled in the art that various changes in form and details may be made therein without departing from the
5 spirit and scope of the invention.

The embodiments of the invention in which an exclusive property or privilege is claimed are defined as follows:

- 1 1. A method for performing an electrophysiological procedure, comprising the steps
2 of:
3 placing a subject in a main magnetic field;
4 introducing an MR-compatible electrode catheter;
5 acquiring a magnetic resonance signal;
6 using magnetic resonance imaging to determine the location of said MR-
7 compatible electrode catheter; and,
8 using said MR-compatible electrode catheter to acquire electrical signals
9 indicative of an electrophysiological state.
10
11
- 1 2. The method according to claim 1, wherein said electrical signals indicative of an
2 electrophysiological state comprise intracardiac electrograms.
3
4
- 1 3. The method according to claim 1, wherein said MR-compatible electrode
2 catheter includes a tip comprising gold.
3
4
- 1 4. The method according to claim 1, wherein said MR-compatible electrode
2 catheter comprises an MR-visible material.
3
4
- 1 5. The method according to claim 3, wherein said MR-visible material comprises a
2 metal.
3

4

1 6. The method according to claim 1, further comprising using a magnetic
2 resonance contrast agent to enhance images acquired in said step of using magnetic
3 resonance imaging to determine the location of said MR-compatible electrode catheter.

4

5

1 7. The method according to claim 1, wherein said step of acquiring a magnetic
2 resonance signal comprises the step of using a magnetic resonance imaging antenna
3 which is integral with said MR-compatible electrode catheter.

4

5

1 8. A method for treating cardiac arrhythmias, comprising the steps of:
2 placing a subject in a main magnetic field;
3 introducing an ablation catheter; and,
4 using magnetic resonance imaging to visualize ablation lesions created using
5 said ablation catheter.

6

7

1 9. The method according to claim 8, wherein said step of using magnetic
2 resonance imaging comprises the step of using a catheter antenna to receive magnetic
3 resonance signals.

4

5

1 10. The method according to claim 9, wherein said catheter antenna comprises a
2 loopless antenna.

3

4

1 11. The method according to claim 9, wherein said catheter antenna comprises a
2 loop antenna.

3

4

1 12. The method according to claim 8, further comprising the step of using a
2 magnetic resonance contrast agent to enhance the visibility of said ablation lesions in
3 MR images.

4

5

1 13. The method according to claim 12, wherein said step of using a magnetic
2 resonance contrast agent comprises the step of using gadolinium-DTPA.

3

4

1 14. A system for performing ablation therapy, comprising:
2 ablation tip means for applying ablative energy to create ablation lesions;
3 catheter means for inserting said diagnostic electrodes into a region to be
4 treated;

5 magnetic resonance antenna means, integral with said catheter means, for
6 receiving magnetic resonance signals; and,

7 means for analyzing said received magnetic resonance signals and for displaying
8 an image of said region to be treated, whereby said means for inserting can be guided
9 to said region to be treated.

10

11

1 15. The system for performing ablation therapy according to claim 14, further
2 comprising:

3 a plurality of diagnostic electrodes.

4

5

1 16. The system for performing ablation therapy according to claim 14, wherein said
2 magnetic resonance antenna means comprises a loopless antenna.

WO 00/25672

PCT/US99/25858

3

4

1

17. A system for magnetic resonance imaging-guided catheter ablation, comprising:

2

means for generating RF ablation current;

3

means for generating an RF magnetic resonance imaging signal in a first frequency range;

4

5

filter means for filtering said first frequency range from said RF ablation current.

6

7

8

1

18. The system according to claim 17, further comprising magnetic resonance antenna means for receiving induced magnetic resonance signals.

2

3

4

1

19. The system according to claim 18, wherein said magnetic resonance antenna means comprises an invasive catheter antenna.

2

3

4

1

20. The system according to claim 19, wherein said invasive catheter antenna comprises a loopless antenna.

2

3

4

1

21. The system according to claim 17, wherein said means for generating a RF magnetic resonance imaging signal comprises means for generating a 64MHz RF magnetic resonance signal and wherein said filter means comprises means for filtering said resonance signal from said ablation signal.

4

5

6

7

1 22. The system according to claim 17, wherein said filter means comprises a low-
2 pass filter.

3

4

1 23. The system according to claim 17, wherein said filter means comprises a multi-
2 stage filter.

3

4

1 24. The system according to claim 17, wherein said filter means comprises means
2 for filtering gradient-induced noise.

3

4

1 25. The system according to claim 24, wherein said means for filtering gradient-
2 induced noise comprises a series of active filters which filter a different frequency
3 range than the RF filters.

4

5

1 26. A method for performing an electrophysiological procedure, comprising the
2 steps of:

3 placing a subject in a main magnetic field;

4 introducing an invasive imaging antenna or coil;

5 acquiring a first magnetic resonance image from said invasive imaging antenna
6 or coil;

7 acquiring a second magnetic resonance image from a surface coil;

8 combining said first and second magnetic resonance images to produce a
9 composite image; and,

10 using said composite image to guide said electrophysiological procedure.

11

12

1 27. The method according to claim 26, wherein said step of using said composite
2 image to guide said electrophysiological procedure comprises the step of using said
3 composite image to guide an ablation procedure.

4

5

1 28. The method according to claim 26, further comprising the step of using said
2 composite image to construct a three-dimensional map of areas in the heart that have
3 undergone ablation.

4

5

1 29. The method according to claim 26, further comprising the step of using said
2 composite image to construct a three-dimensional rendering of the heart.

3

4

1 30. The method according to claim 29, further comprising the step of storing said
2 three-dimensional rendering into a texture map of an imaging volume.

3

4

1 31. A system for magnetic resonance imaging-guided catheter ablation, comprising:
2 electrode means for receiving electrical signals indicative of an
3 electrophysiological state, said electrical signals being within a first frequency range;
4 means for generating an RF magnetic-resonance-inducing signal;
5 magnetic resonance antenna means for receiving magnetic resonance signals
6 from a region to be treated;
7 filter means for filtering said first frequency range from said RF magnetic-
8 resonance-inducing signal.

9

10

1 32. A combined electrophysiology and imaging catheter, comprising:

WO 00/25672

PCT/US99/25858

2 at least one diagnostic electrode;
3 catheter for inserting said diagnostic electrode into a region to be studied; and,
4 an invasive magnetic resonance antenna, integral with said catheter, for
5 receiving magnetic resonance signals.
6
7

1 33. The combined electrophysiology and imaging catheter according to claim 32,
2 further comprising:

3 steering device for deflecting said catheter, whereby said catheter can be steered
4 to said region to be studied.
5
6

1 34. The combined electrophysiology and imaging catheter according to claim 33,
2 wherein said steering device comprises a steering wire.
3
4

1 35. The combined electrophysiology and imaging catheter according to claim 34,
2 wherein said steering wire is of a titanium construction.
3
4

1 36. The combined electrophysiology and imaging catheter according to claim 35,
2 wherein said steering wire is housed in a sheath.
3
4

1 37. The combined electrophysiology and imaging catheter according to claim 33,
2 wherein said steering device comprises a steering knob.
3
4

1 38. The combined electrophysiology and imaging catheter according to claim 37,

2 wherein said steering knob is operable to move a steering wire toward or away from a
3 distal tip of said catheter.

4

5

1 39. The combined electrophysiology and imaging catheter according to claim 32,
2 further comprising:

3 an ablation tip for applying ablative energy to a region to be treated.

4

5

1 40. The combined electrophysiology and imaging catheter according to claim 32,
2 further comprising:

3 a flexible antenna whip at a distal portion of said catheter.

4

5

1 41. The combined electrophysiology and imaging catheter according to claim 40,
2 wherein said flexible antenna whip is coated with an insulating layer.

3

4

1 42. The combined electrophysiology and imaging catheter according to claim 40,
2 wherein said flexible antenna whip comprises a tip which is formed into a J-shape to
3 prevent perforation.

4

5

1 43. The combined electrophysiology and imaging catheter according to claim 32,
2 wherein said catheter and all components housed therein are fabricated of materials
3 having low-magnetic susceptibility.

4

5

1 44. The combined electrophysiology and imaging catheter according to claim 32,

2 further comprising a tip which is at least 4 millimeters in length and suitable for use in
3 RF ablation procedures.

4

5

1 45. The combined electrophysiology and imaging catheter according to claim 44,
2 wherein said tip is fabricated from platinum.

3

4

1 46. The system for performing ablation therapy according to claim 14, wherein said
2 magnetic resonance antenna means comprises a loop antenna.

3

4

1 47. The system according to claim 24, wherein said means for filtering gradient-
2 induced noise comprises a series of passive filters which filter a different frequency
3 range than the RF filters.

4

5

1 48. The combined electrophysiology and imaging catheter according to claim 34,
2 wherein said steering wire is of a non-magnetic construction.

3

4

1 49. The combined electrophysiology and imaging catheter according to claim 44,
2 wherein said tip is fabricated from gold.

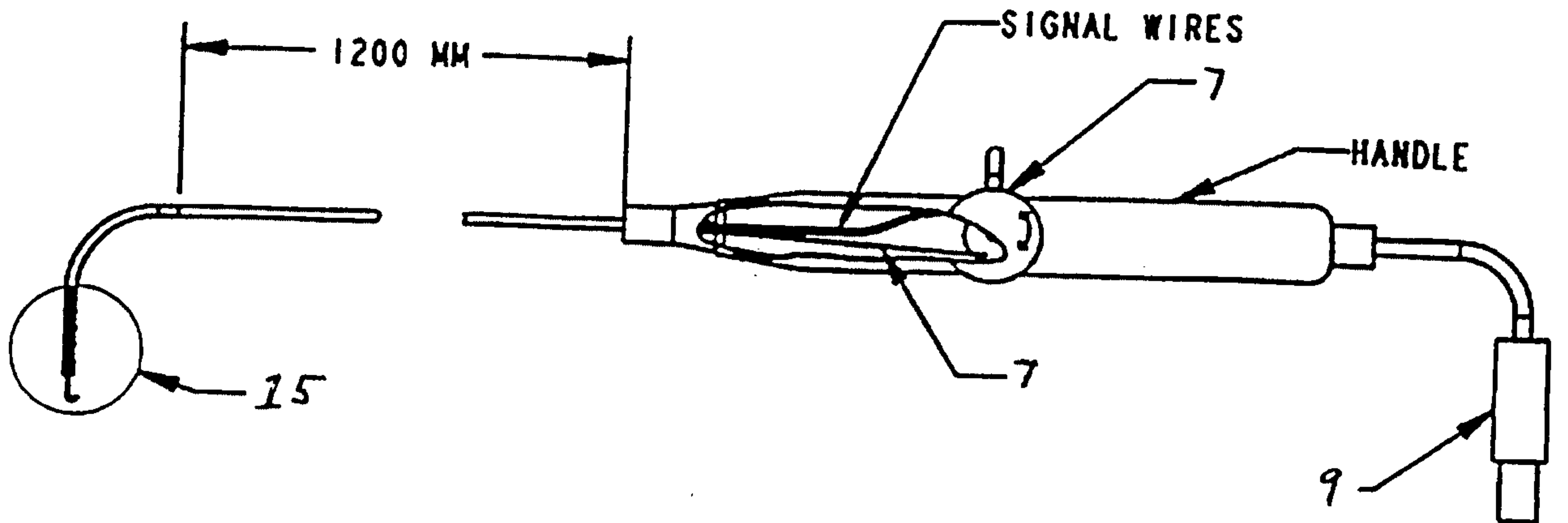

Figure 1

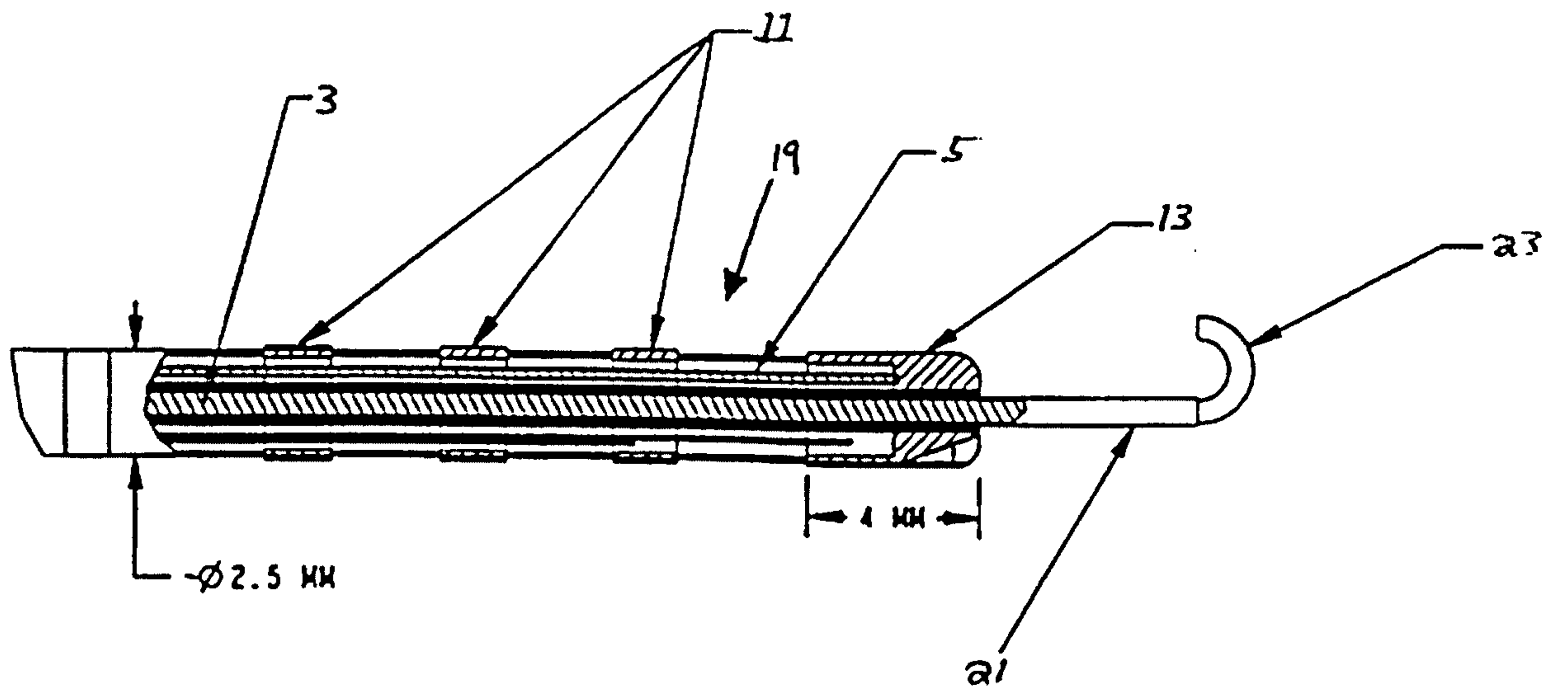

Figure 2

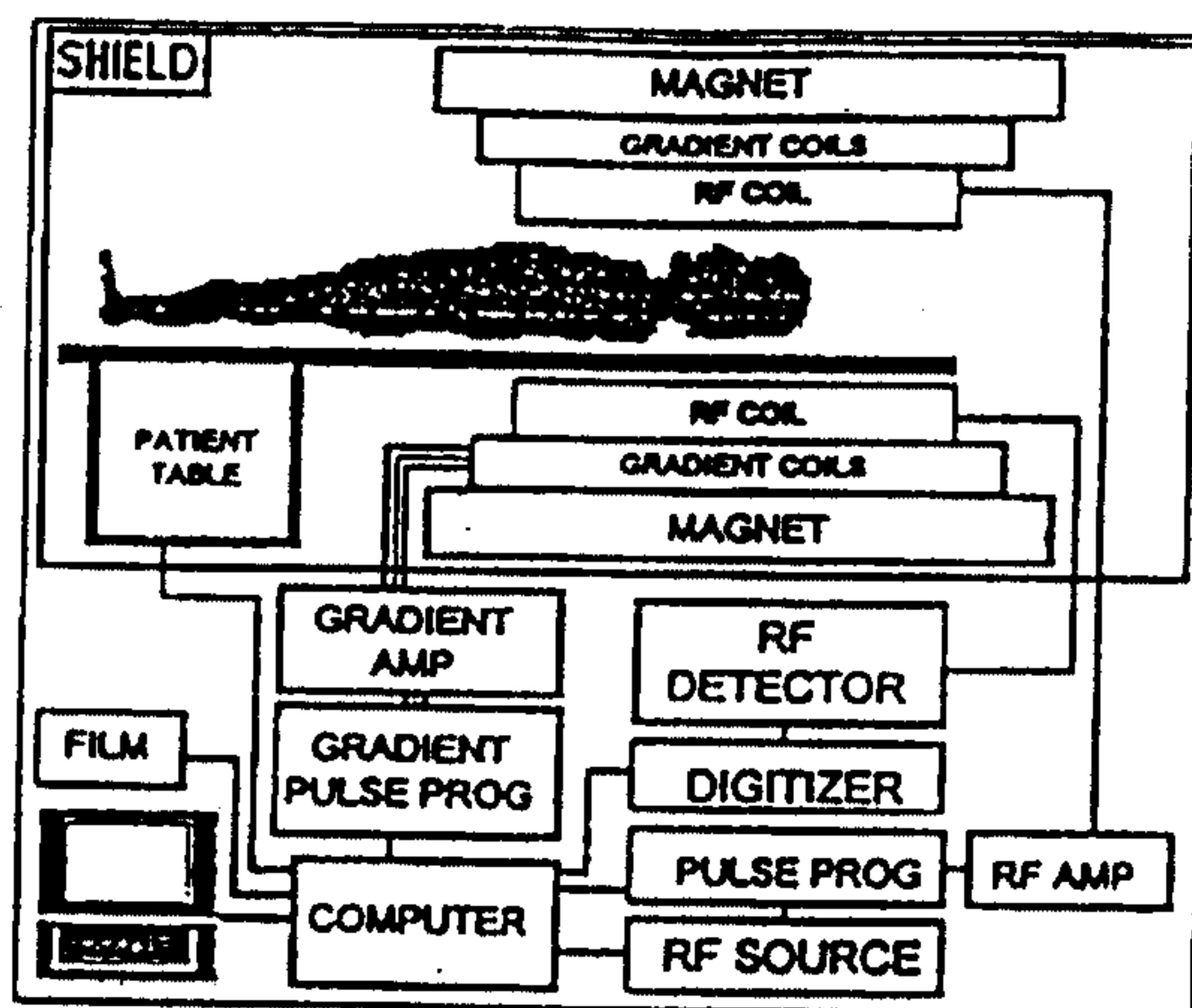

Figure 3

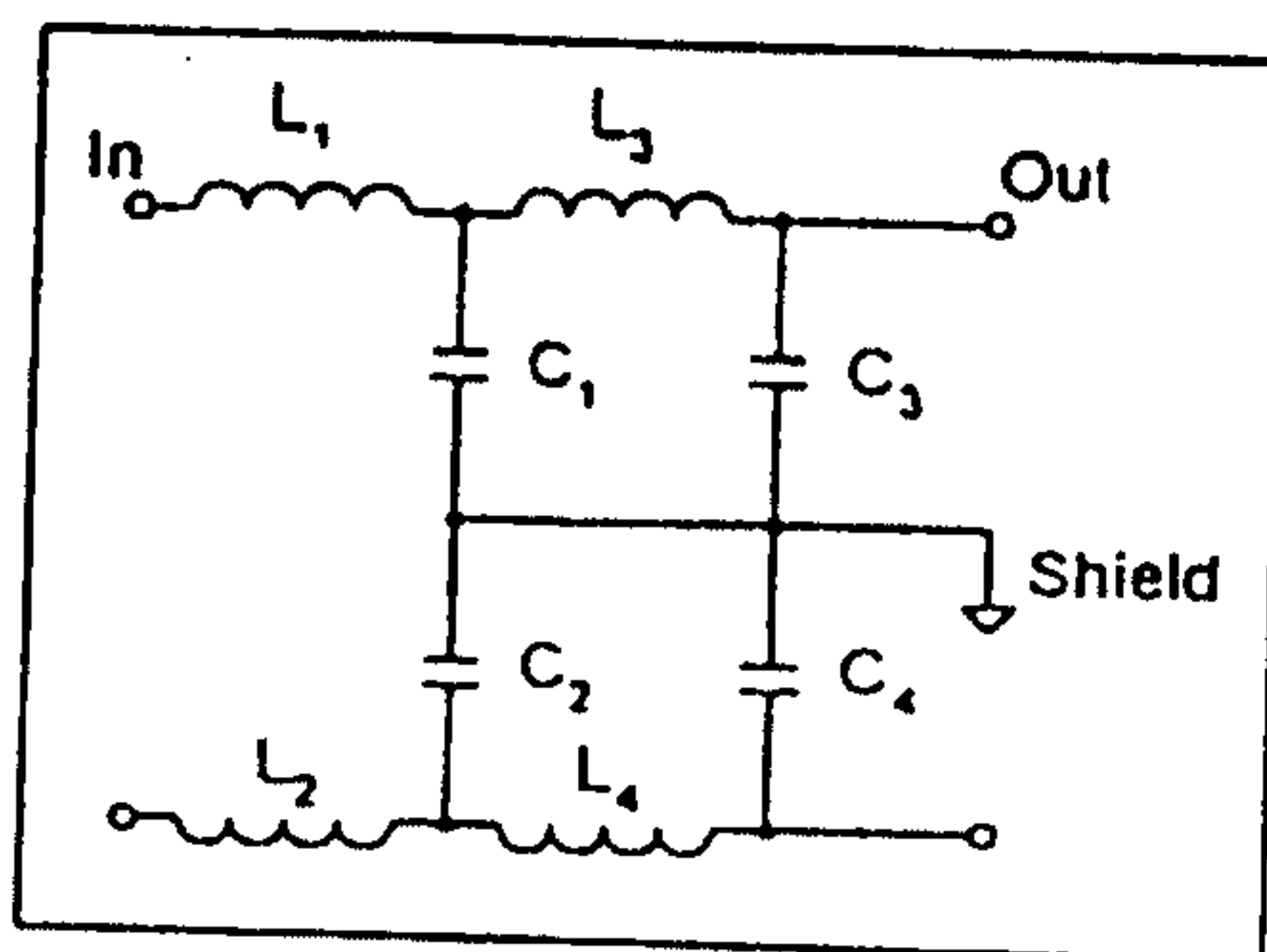

Figure 4

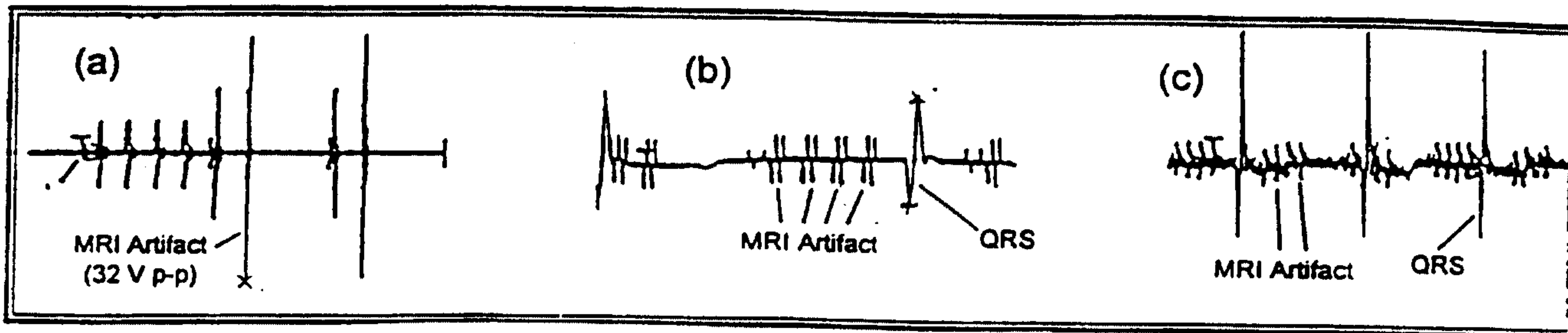

Figure 5

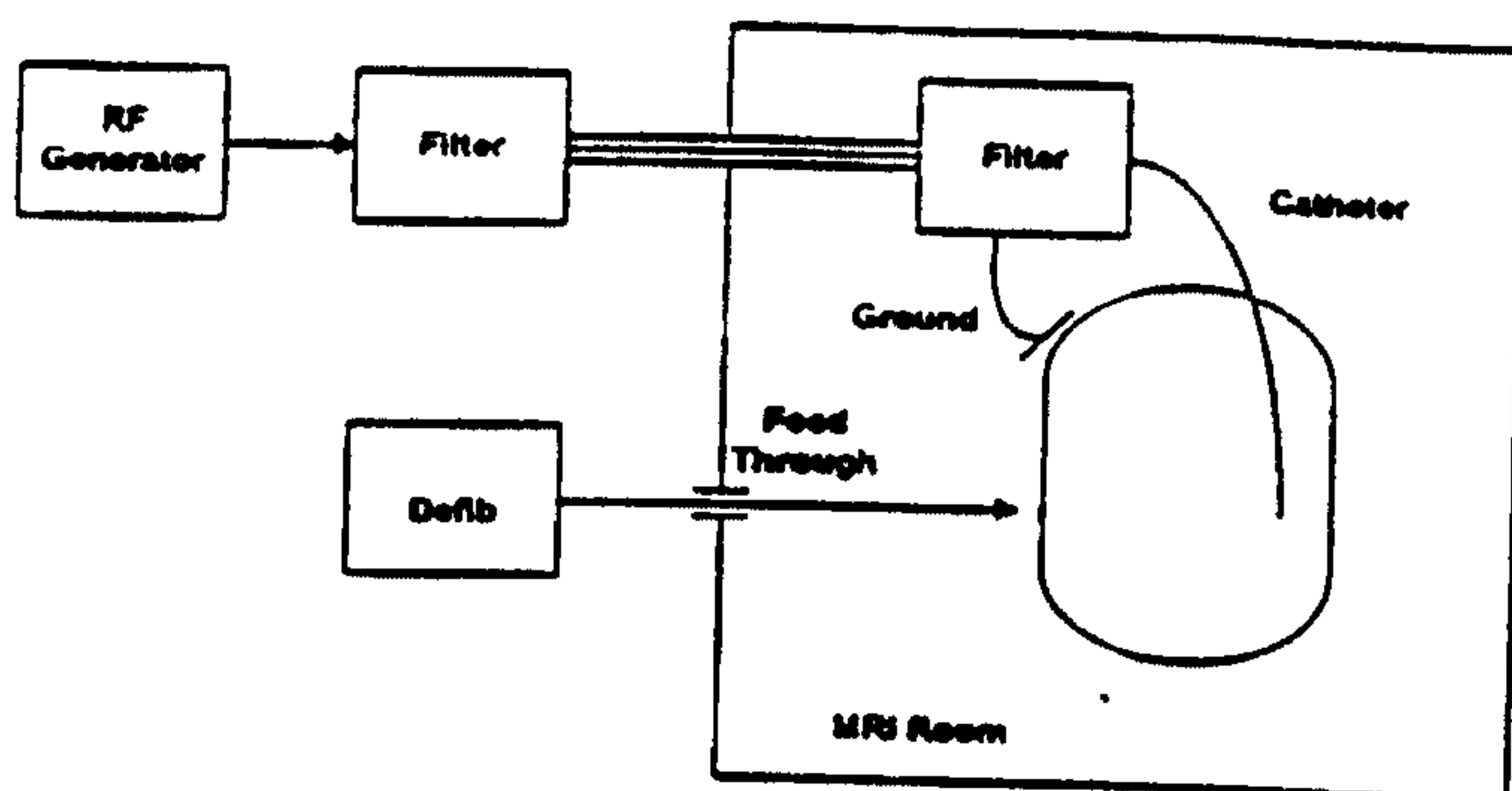

Figure 6

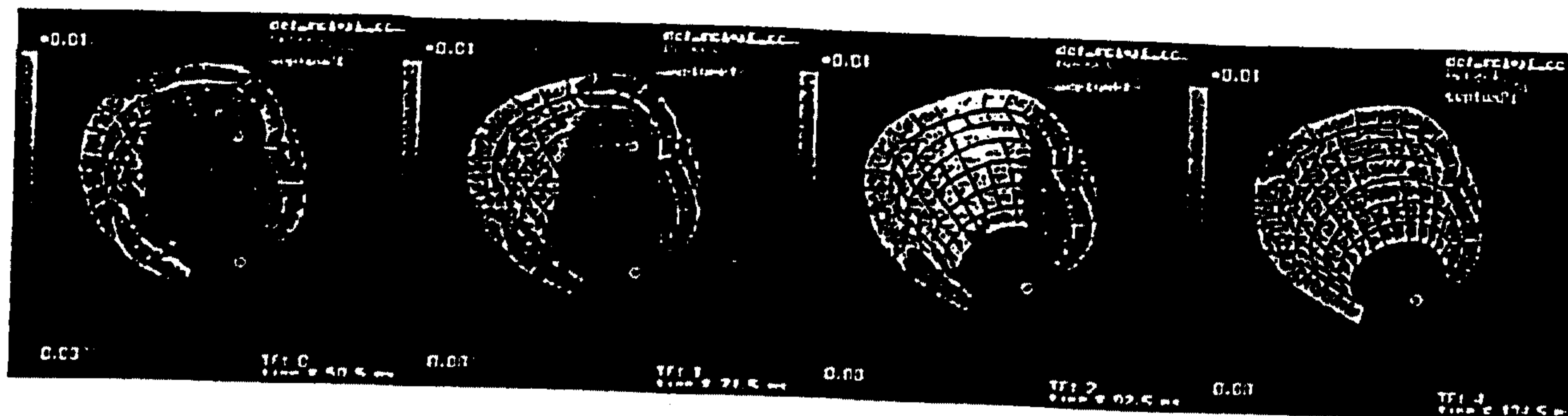

FIGURE 7

