

**(12) PATENT**  
**(19) AUSTRALIAN PATENT OFFICE**

**(11) Application No. AU 199724549 B2**  
**(10) Patent No. 721001**

(54) Title  
**Method of sterilization in diffusion-restricted environments**

(51)<sup>7</sup> International Patent Classification(s)  
**A61L 002/14                      A61L 002/20**

(21) Application No: **199724549**

(22) Application Date: **1997.04.04**

(87) WIPO No: **WO97/37692**

(30) Priority Data

(31) Number	(32) Date	(33) Country
<b>08/628965</b>	<b>1996.04.04</b>	<b>US</b>

(43) Publication Date : **1997.10.29**

(43) Publication Journal Date : **1998.01.08**

(44) Accepted Journal Date : **2000.06.22**

(71) Applicant(s)  
**Ethicon, Inc.**

(72) Inventor(s)  
**Paul Taylor Jacobs; John Morrell Jacobs; Szu-Min Lin; Tralance O. Addy**

(74) Agent/Attorney  
**FREEHILLS CARTER SMITH and BEADLE, Level 47, 101 Collins Street, MELBOURNE  
VIC 3000**

(56) Related Art  
**EP 456135**  
**EP 302419**

OPI DATE 29/10/97 APPLN. ID 24549/97  
AOJP DATE 08/01/98 PCT NUMBER PCT/US97/06017



INTE

AU9724549

(51) International Patent Classification 6 :  
A61L 2/14, 2/20

A1

(11) International Publication Number: **WO 97/37692**

(43) International Publication Date: 16 October 1997 (16.10.97)

(21) International Application Number: PCT/US97/06017

(22) International Filing Date: 4 April 1997 (04.04.97)

(30) Priority Data:  
08/628,965 4 April 1996 (04.04.96) US

*ETHICON, INC.*  
(71) Applicant: ~~JOHNSON & JOHNSON MEDICAL, INC.~~  
[US/US]; One Johnson & Johnson Plaza, New Brunswick,  
NJ 08933-7033 (US).

(72) Inventors: JACOBS, Paul, Taylor; 8 Rainier, Trabuco Canyon,  
CA 92679 (US). JACOBS, John, Morrell; 8 Rainier,  
Trabuco Canyon, CA 92679 (US). LIN, Szu-Min; 25632  
Rain Tree Road, Laguna Hills, CA 92653 (US). ADDY,  
Tralance, O.; 8 Palomino, Coto de Caza, CA 92679 (US).

(74) Agent: ALTMAN, Daniel, E.; Knobbe, Martens, Olson & Bear,  
16th floor, 620 Newport Center Drive, Newport Beach, CA  
92660 (US).

(81) Designated States: AL, AM, AT, AU, AZ, BA, BB, BG, BR,  
BY, CA, CH, CN, CU, CZ, DE, DK, EE, ES, FI, GB, GE,  
HU, IL, IS, JP, KE, KG, KP, KR, KZ, LC, LK, LR, LS,  
LT, LU, LV, MD, MG, MK, MN, MW, MX, NO, NZ, PL,  
PT, RO, RU, SD, SE, SG, SI, SK, TJ, TM, TR, TT, UA,  
UG, UZ, VN, ARIPO patent (GH, KE, LS, MW, SD, SZ,  
UG), Eurasian patent (AM, AZ, BY, KG, KZ, MD, RU, TJ,  
TM), European patent (AT, BE, CH, DE, DK, ES, FI, FR,  
GB, GR, IE, IT, LU, MC, NL, PT, SE), OAPI patent (BF,  
BJ, CF, CG, CI, CM, GA, GN, ML, MR, NE, SN, TD, TG).

Published *with international search report.*



(54) Title: METHOD OF STERILIZATION IN DIFFUSION-RESTRICTED ENVIRONMENTS

(57) Abstract

Methods for peroxide vapor sterilization of medical devices and similar instruments having long narrow lumens or diffusion restricted areas includes the step of contacting the article to be sterilized or a diffusion-restricted environment containing said article with a source of peroxide prior to exposure to a vacuum or a vacuum followed by plasma. The methods are such that, upon vaporization of the source of peroxide caused by the vacuum, the peroxide remains in contact with the article for a time sufficient to achieve sterilization.

**METHOD OF STERILIZATION IN DIFFUSION-RESTRICTED ENVIRONMENTS****Background of the Invention****Field of the Invention**

This invention relates to a process for using a source of peroxide and negative pressure to sterilize articles such as  
5 medical instruments, and more particularly, to methods which include the step of contacting the articles or the diffusion-  
restricted environment containing the articles with a source of peroxide prior to exposure to negative pressure or negative  
pressure combined with plasma.

**Description of the Related Art**

Medical instruments have traditionally been sterilized using either heat, such as is provided by steam, or a  
10 chemical, such as formaldehyde or ethylene oxide in the gas or vapor state. Each of these methods has drawbacks.  
Many medical devices, such as fiberoptic devices, endoscopes, power tools, etc. are sensitive to heat, moisture, or both.  
Formaldehyde and ethylene oxide are both toxic gases that pose a potential hazard to healthcare workers. Problems with  
ethylene oxide are particularly severe, because its use requires long aeration times to remove the gas from articles that  
have been sterilized. This makes the sterilization cycle time undesirably long.

15 Sterilization using liquid hydrogen peroxide solution has been found to require high concentration of sterilant,  
extended exposure time and/or elevated temperatures. However, sterilization using hydrogen peroxide vapor has been  
shown to have some advantages over other chemical sterilization processes (see, e.g., U.S. Pat. Nos. 4,169,123 and  
4,169,124). The combination of hydrogen peroxide with a plasma provides certain additional advantages, as disclosed  
in U.S. Pat. 4,643,876, issued February 17, 1987 to Jacobs et al.. U.S. Pat. 4,756,882, issued July 12, 1988 also to  
20 Jacobs et al. discloses the use of hydrogen peroxide vapor, generated from an aqueous solution of hydrogen peroxide,  
as a precursor of the reactive species generated by a plasma generator. The combination of hydrogen peroxide vapor  
diffusing into close proximity with the article to be sterilized and plasma acts to sterilize the articles, even within closed  
packages. Further, these methods of combining hydrogen peroxide vapor with a plasma, while useful in "open" systems,  
have been found to be inadequate to effect sterilization in articles having diffusion-restricted areas, since the methods  
25 are dependent upon diffusion of the sterilant vapor into close proximity with the article before sterilization can be  
achieved. Thus, these methods have been found to require high concentration of sterilant, extended exposure time and/or  
elevated temperatures when used on long, narrow lumens. For example, lumens longer than 27 cm and/or having an  
internal diameter of less than 0.3 cm have been particularly difficult to sterilize. Thus, no simple, safe, effective method  
of sterilizing smaller lumens exists in the prior art.

30 The sterilization of articles containing diffusion-restricted areas, such as long narrow lumens, therefore presents  
a special challenge. Methods that use hydrogen peroxide vapor that has been generated from an aqueous solution of  
hydrogen peroxide have certain disadvantages, because:

1. Water has a higher vapor pressure than hydrogen peroxide and will vaporize faster than hydrogen  
peroxide from an aqueous solution.
- 35 2. Water has a lower molecular weight than hydrogen peroxide and will diffuse faster than hydrogen  
peroxide in the vapor state.

Because of this, when an aqueous solution of hydrogen peroxide is vaporized in the area surrounding the items to be sterilized, the water reaches the items first and in higher concentration. The water vapor therefore becomes a barrier to the penetration of hydrogen peroxide vapor into diffusion restricted areas, such as small crevices and long narrow lumens. One cannot solve the problem by removing water from the aqueous solution and using more concentrated hydrogen peroxide, since, among other reasons, concentrated solutions of hydrogen peroxide greater than 65% by weight can be hazardous due to the oxidizing nature thereof.

U.S. Pat. 4,952,370 to Cummings et al. discloses a sterilization process wherein aqueous hydrogen peroxide vapor is first condensed on the article to be sterilized, and then a source of vacuum is applied to the sterilization chamber to evaporate the water and hydrogen peroxide from the article. This method is suitable to sterilize surfaces, however, it is ineffective at rapidly sterilizing diffusion-restricted areas, such as those found in lumened devices, since it too depends on the diffusion of the hydrogen peroxide vapor into the lumen to effect sterilization.

U.S. Pat. 4,943,414, entitled "Method for Vapor Sterilization of Articles Having Lumens," and issued to Jacobs et al., discloses a process in which a vessel containing a small amount of a vaporizable liquid sterilant solution is attached to a lumen, and the sterilant vaporizes and flows directly into the lumen of the article as the pressure is reduced during the sterilization cycle. This system has the advantage that the water and hydrogen peroxide vapor are pulled through the lumen by the pressure differential that exists, increasing the sterilization rate for lumens, but it has the disadvantage that the vessel needs to be attached to each lumen to be sterilized. In addition, water is vaporized faster and precedes the hydrogen peroxide vapor into the lumen.

In U.S. Patent No. 5,492,672, there is disclosed a process for sterilizing narrow lumens. This process uses a multicomponent sterilant vapor and requires successive alternating periods of flow of sterilant vapor and discontinuance of such flow. A complex apparatus is used to accomplish the method. Because flow through of vapor is used, closed end lumens are not readily sterilized in the process.

Thus, there remains a need for a simple and effective method of vapor sterilization of articles having areas where diffusion of these vapors is restricted, such as long, narrow lumens.

25

#### Summary of the Invention

One aspect of the present invention relates to a method for sterilizing an interior of an article with a diffusion restricted area, such as an article having a lumen. The method includes the steps of contacting the interior of the article with a source of peroxide, and exposing the article to negative pressure for a time period sufficient to effect complete sterilization. In one embodiment, the source of peroxide comprises a liquid or condensed vapor. In another embodiment, the source of peroxide comprising a liquid comprises hydrogen peroxide or peracetic acid. In another embodiment, the source of peroxide comprising a condensed vapor comprises hydrogen peroxide or peracetic acid vapor. If the exposing step is conducted for 1 hour at 40°C and 10 torr, and the source of peroxide comprises 1 mg/L hydrogen peroxide, the diffusion restricted area preferably retains 0.17 mg/L or more hydrogen peroxide, or retains 17% or more of the hydrogen peroxide placed therein after the exposing step. In certain preferred embodiments, the diffusion-restricted area has the same or more diffusion restriction than provided by a lumen 27 cm in length and an internal diameter of 3 mm, or has the same or more diffusion restriction than provided by a lumen having a ratio of length to internal diameter greater

than 50. The source of peroxide is preferably at a concentration of less than 25% by weight. The contacting step can be performed by delivery via a method such as injection, static soak, liquid flow-through, aerosol spray, condensation or physical placement. In a preferred embodiment, the diffusion-restricted area is a lumen at least 27 cm in length and having an internal diameter of no more than 3 mm, more preferably having an internal diameter of no more than 1 mm.

5 The exposing step is preferably performed for 60 minutes or less, and is preferably performed at a pressure less than the vapor pressure of hydrogen peroxide. Thus, the preferred pressure range under conditions of the present invention is between 0 and 100 torr. In one particularly preferred embodiment, the pressure is approximately 10 torr and the exposing step is conducted at a temperature of approximately 23°C to approximately 28°C. The exposing step can include the step of heating the article, such as by heating the chamber in which the exposing step occurs. The chamber

10 can be heated to about 40°C to about 45°C. Alternatively, the source of peroxide can be heated, such as to a temperature of about 40°C to about 45°C. Optionally, the step of exposing the device to a plasma can be conducted during the step of exposing the device to negative pressure. In one embodiment employing exposure to plasma, the method is performed within a first chamber and the plasma is generated in a second, separate chamber. This embodiment further comprises the step of flowing the plasma into the first chamber. Advantageously, the contacting

15 and/or exposing steps of the method can be repeated one or more times.

Another aspect of the present invention relates to a method for sterilizing an interior and an exterior of an article. This method includes the following steps: contacting the article with a source of peroxide; and placing the article in a diffusion-restricted environment. The contacting and placing steps can be performed in either order. These steps are followed by exposing the diffusion-restricted environment to negative pressure for a time period sufficient to

20 effect complete sterilization. The contacting step can be performed both before and after the placing step. If the exposing step is conducted at 40°C and 10 torr, and a source of peroxide comprising 1 mg/L of hydrogen peroxide is introduced, the diffusion restricted environment preferably retains 0.17 mg/L or more hydrogen peroxide after the exposing step, or retains 17% or more of the hydrogen peroxide placed therein after the exposing step. The exposing step can include the step of heating the article, such as by heating the chamber in which the exposing step occurs or by heating

25 the source of peroxide. In certain preferred embodiments, the diffusion-restricted environment has the same or more diffusion restriction than provided by a single entry/exit port of 9 mm or less in internal diameter and 1 cm or greater in length, or is sufficiently diffusion restricted to completely sterilize a stainless steel blade within a 2.2 cm by 60 cm glass tube having a rubber stopper with a 1 mm by 50 cm stainless steel exit tube therein at a vacuum of 10 torr for one hour at 40°C. In one embodiment, the source of peroxide comprises a liquid or condensed vapor. In another

30 embodiment, the source of peroxide comprising a liquid comprises hydrogen peroxide or peracetic acid. In another embodiment, the source of peroxide comprising a condensed vapor comprises hydrogen peroxide or peracetic acid vapor. The contacting step can be by delivery via a method such as injection, static soak, liquid flow-through, aerosol spray, condensation or physical placement. Plasma can also be used during the step of exposing the lumen to negative pressure. If plasma is used, the method can be performed within a sealed chamber and the plasma generated within the container.

35 Thus, the method can be performed within a first chamber and the plasma generated in a second, separate chamber and the plasma flowed into the first chamber. The diffusion-restricted container can have at least one exit tube, such as

one that is at least 1.0 cm in length and has an internal diameter of 9 mm or less. The exit tube can also include a filter. In a preferred embodiment, the filter is sufficient to prevent entry of bacteria from the environment into the container. The source of peroxide can be used at a concentration of less than 25% by weight. The exposing step is preferably performed for 60 minutes or less. The method can be conducted along with the step of heating the article  
5 during the exposing step. Thus, the exposing step can be conducted within a chamber, and the chamber heated during the exposing step. The exposing step can be conducted at a negative pressure between 0 and 100 Torr. Advantageously, the various steps of this method can also be repeated one or more times.

Still one more aspect of the invention relates to a method for making a sterilized article within a diffusion-restricted container. This method includes contacting the article with a source of peroxide, and placing the article in  
10 the diffusion-restricted container in either order. If the initial contacting step precedes the placing step, the contacting step can be repeated after the placing step. These steps are followed by exposing the diffusion-restricted container to negative pressure for a time period sufficient to effect complete sterilization of the article. The container used in this aspect of the invention has at least one exit tube. The exit tube preferably has a filter therein which is preferably sufficient to prevent entry of bacteria into the container. The exit tube is at least 1.0 cm in length and/or has an internal  
15 diameter of 9 mm or less. Advantageously, the exposing step, the contacting step, or the entire method can be repeated one or more times. In a preferred embodiment, the contacting step comprises delivery via injection, static soak, liquid flow-through, aerosol spray, condensation or physical placement. The container can be exposed to a plasma during the step of exposing the container to negative pressure. In one embodiment, the method is performed within a sealed chamber and the plasma is generated within the chamber. The exposing step is preferably performed for 60 minutes  
20 or less and/or at a pressure between 0 and 100 Torr. The container can be heated during the exposing step, or the source of peroxide heated prior to the contacting step. The invention also includes the sterilized article within a diffusion-restricted container produced by the method of this aspect. In one embodiment, the source of peroxide comprises a liquid or condensed vapor. In another embodiment, the source of peroxide comprising a liquid comprises hydrogen peroxide or peracetic acid. In another embodiment, the source of peroxide comprising a condensed vapor comprises hydrogen peroxide  
25 or acetic acid vapor.

Still one more aspect of the invention relates to a method for making a sterilized article within a diffusion-restricted container. This method includes placing the article in the diffusion-restricted container and contacting the container with a source of peroxide, in either order. These steps are followed by exposing the diffusion-restricted container to negative pressure for a time period sufficient to effect complete sterilization of the article. The container  
30 used in this aspect of the invention has at least one communication port comprising an exit tube or air and vapor permeable window. The exit tube preferably has a filter therein which is preferably sufficient to prevent entry of bacteria into the container. The exit tube is at least 1.0 cm in length and/or has an internal diameter of 9 mm or less. The communication port is preferably connected through a connector to the article to be sterilized, so that sterilant vapor may flow through the article and out of the container. The connector is preferably tubing or an adaptor which can be  
35 attached to a lumen of said article, or an enclosure which contains a portion of the article with the lumen. In one embodiment, the exit tube is additionally connected to a valve outside the container and the valve is connected with a

vacuum source. In one embodiment, the communication port comprising a window is impermeable to microorganisms. Advantageously, the exposing step, the contacting step, or the entire method can be repeated one or more times. In a preferred embodiment, the contacting step comprises delivery via injection, static soak, liquid flow-through, aerosol spray, condensation or physical placement. The container can be exposed to a plasma during the step of exposing the  
5 container to negative pressure. In one embodiment, the method is performed within a sealed chamber and the plasma is generated within the chamber. The exposing step is preferably performed for 60 minutes or less and/or at a pressure between 0 and 100 Torr. The container can be heated during the exposing step, or the source of peroxide heated prior to the contacting step. The invention also includes the sterilized article within a diffusion-restricted container produced by the method of this aspect. In one embodiment, the source of peroxide comprises a liquid, a solid or condensed vapor.  
10 In another embodiment, the source of peroxide comprising a liquid comprises hydrogen peroxide or peracetic acid. In another embodiment, the source of peroxide comprising a solid comprises a urea peroxide complex or sodium pyrophosphate peroxide complex or like complex. In another embodiment, the source of peroxide comprising a condensed vapor comprises hydrogen peroxide or acetic acid vapor.

#### Brief Description of the Drawings

15 FIGURE 1 is a cross-sectional illustration of a lumen containing an inoculated stainless steel blade placed within a glass tube having only a narrow opening to create a diffusion-restricted environment for testing the sterilization method of the present invention.

FIGURE 2 is a cross-sectional illustration of an inoculated stainless steel blade placed directly within a glass tube having only a narrow opening to create an alternate diffusion-restricted environment for testing the sterilization  
20 method of the present invention.

FIGURE 3 is a cross-sectional illustration of an inoculated stainless steel blade placed directly within a glass tube having a filter placed at its narrow opening to create an alternate diffusion-restricted environment for testing the sterilization method of the present invention.

FIGURE 4 is a cross-sectional illustration of one embodiment of a diffusion restricted environment represented  
25 by a container having a limited diffusion port (communication port consisting of tubing).

FIGURE 5A is a cross-sectional illustration of one embodiment of a diffusion restricted environment represented by a container having a limited diffusion port (communication port consisting of tubing or the lumen device) and a tubing connector to connect a lumen device to the communication port of the container.

FIGURE 5B is a cross-sectional illustration of one embodiment of a diffusion restricted environment represented  
30 by a container having a limited diffusion port (communication port consisting of tubing or the lumen device) and an enclosure connector to connect a lumen device to the communication port of the container.

FIGURE 6 is a cross-sectional illustration of one embodiment of a diffusion restricted environment represented by a container having a limited diffusion port and an enclosure connector to connect a lumen device to the window.

#### Detailed Description of the Preferred Embodiment

35 Sterilizing the inside of lumened devices has always posed a challenge to sterilization systems. Achieving rapid sterilization of lumened devices or other diffusion restricted articles at low temperatures and low concentrations of

sterilant represents an even greater challenge. In the present invention, the shortcomings of the prior art sterilization systems are overcome by pre-treating or contacting articles to be sterilized with a source of peroxide prior to exposure to a vacuum, or optionally, plasma. Alternatively, a diffusion-restricted environment containing articles to be sterilized can be contacted with a source of peroxide prior to exposure to a vacuum. The source of peroxide comprises a liquid or condensed vapor in the case wherein an article is contacted. In the case wherein a diffusion-restricted environment is contacted, the source of peroxide additionally comprises a solid. The liquid comprises aqueous solutions of hydrogen peroxide or peracetic acid. The solid comprises a urea peroxide complex, or sodium pyrophosphate peroxide complex or like peroxide complex. The vapor comprises hydrogen peroxide or peracetic acid vapor. The preferred method of the present invention utilizes aqueous hydrogen peroxide as the source of peroxide to contact an article to be sterilized. The methods of the present invention provide for the rapid sterilization of lumened and non-lumened articles under conditions that will not damage the articles nor leave toxic residues on the sterile articles.

In the method of the present invention, the source of the peroxide is delivered into direct contact with the article to be sterilized or with the diffusion-restricted environment containing the article to be sterilized. In the case of a lumened device, the source of peroxide may be delivered directly into the lumen. In the case of an article having an area where diffusion of vapor is restricted, the source of peroxide may be delivered to the interior of the diffusion restricted area. For articles which are not diffusion-restricted, the source of peroxide can be introduced anywhere into the diffusion-restricted environment. The source of peroxide is delivered into the lumen or into contact with the article to be sterilized or into contact with the diffusion-restricted environment containing the article to be sterilized through means such as direct delivery or physical placement, a static soaking process, a liquid flow-through process, by aerosol spray or by condensation of a vapor. Physical placement also includes placement of a reservoir containing the source of peroxide. In the preferred method of the present invention, the aqueous solutions of hydrogen peroxide can be relatively dilute, e.g., as low as 1-6% or lower by weight, since sterilization is not achieved through contact with the hydrogen peroxide solution, but rather, is achieved at low temperatures and in short periods of time upon exposure to hydrogen peroxide vapor under vacuum or vacuum combined with plasma. The method of the present invention is particularly effective with articles having inaccessible or hard-to-reach places. Such articles include long, narrow lumens, hinges, and other articles having spaces where diffusion of vapors is restricted.

The general operation of one embodiment of a preferred method of the present invention, which is useful for sterilizing the inside of long, narrow lumens, is as follows:

1. The lumen to be sterilized is contacted with a source of peroxide. The source of peroxide can be physically delivered as a small amount directly into the lumen, or by static soaking, liquid flow-through, aerosol spray or condensation of a vapor.
2. The lumen to be sterilized is placed within a chamber, and the chamber is sealed and evacuated. (The source of peroxide can also be delivered to the inside of the article after placing the article in the chamber.)
3. The lumen is exposed to the vacuum for a period of time and at a temperature sufficient to effect sterilization.
4. The sterile lumen is removed from chamber.



In an alternative embodiment of the method of the present invention, a similar method is used to sterilize both the inside and outside of an article. In this alternative embodiment, the article to be sterilized is placed in a diffusion-restricted environment. The diffusion-restricted environment can be a rigid container or flexible pouch having at least one exit tube. In this embodiment, the exit tube is preferably diffusion-restricted. Alternatively, it is not necessary that the exit tube be diffusion-restricted so long as diffusion of sterilant vapor is limited by the article to be sterilized, such as the case wherein sterilant vapor must flow through a limited diffusion area or lumen of an article to be sterilized. This depends upon the configuration of the container. The exit tube may be constructed from a variety of materials, such as glass, metals and plastics and may include a filter. The filter may be sufficient to prevent entry of bacteria from the environment into the container. The source of peroxide is introduced to the inside of the article. The source of peroxide can be introduced either before or after placing the article in the diffusion-restricted environment. The diffusion-restricted environment containing the article to be sterilized is then placed in the chamber, exposed to vacuum and removed as in steps 2 through 4 above.

The general operation of an alternative embodiment of the method of the present invention, which is also useful for sterilizing the inside of long, narrow diffusion-restricted lumens, is as follows:

1. The article to be sterilized is placed in a diffusion-restricted environment such as a container, said container comprising at least one communication port comprising an exit tube or air and vapor permeable window; and
2. The diffusion-restricted environment is contacted with a source of peroxide, steps 1. and 2. being performed in either order; followed by
3. The diffusion-restricted environment is exposed to negative pressure for a time period sufficient to effect complete sterilization of said article.

The communication port is preferably connected through a connector to the article, so that sterilant vapor may flow through the article and out of the container. In this embodiment, the communication port comprising an exit tube or air and vapor permeable window is also preferably diffusion-restricted. Alternatively, it is not necessary that the communication port, in particular an air and vapor permeable window, be a limited diffusion port so long as diffusion of sterilant vapor is limited by the article to be sterilized, such as the case wherein sterilant vapor must flow through a limited diffusion area or lumen of an article to be sterilized. This depends upon the configuration of the container. The exit tube may be constructed from a variety of materials, such as glass, metals and plastics and may include a filter. The filter may be sufficient to prevent entry of bacteria from the environment into the container. The air and vapor permeable window may be constructed from permeable materials such as Tyvek.

In yet another alternative embodiment of the present invention which pertains to all of the above methods, the article to be sterilized is exposed to a vacuum followed by low temperature plasma for a time sufficient to effect sterilization. When used in the present specification and claims, the term "plasma" is intended to include any portion of the gas or vapor that contains electrons, ions, free radicals, dissociated and/or excited atoms or molecules produced as a result of an applied electric field, including any accompanying radiation that might be produced. The applied field may cover a broad frequency range; however, a radio frequency or microwaves are commonly used.

The sterilization methods of the present invention can also be used with plasmas generated by the method disclosed in the previously mentioned U.S. Pat. 4,643,876. Alternatively, the methods of the present invention may be used with plasmas described in U.S. Patent 5,115,166 or 5,087,418, in which the article to be sterilized is located in a chamber that is separated from the plasma source.

5 The present invention provides several advantages over earlier vapor sterilization systems, such as, (1) the rapid sterilization of lumened devices and diffusion restricted articles can be rapidly achieved at low temperatures; (2) the use of concentrated, potentially hazardous, solutions of anti-microbials is avoided; (3) the need to attach a special vessel to deliver sterilant vapors into long, narrow lumens is eliminated; (4) no toxic residues remain; (5) since the product is dry at the end of the process, sterile storage of these articles can be achieved; (6) closed end lumens can be sterilized; 10 and (7) the process can be repeated as desired without undue effects. The method of the present invention therefore provides for a highly efficient, nonhazardous, and relatively inexpensive method of sterilization.

To determine the efficacy of the preferred sterilization method of the present invention, preliminary tests were first performed to evaluate the effect of dilute hydrogen peroxide solutions on contaminated surfaces in an open, non-diffusion restricted environment. These tests are described below in Example 1.

15

#### Example 1

To evaluate the sterilization efficacy of dilute hydrogen peroxide solution alone, a biological challenge consisting of  $2.5 \times 10^6$  *Bacillus stearothermophilus* spores on a stainless steel scalpel blade was used. Inoculated blades were submerged in 40 ml of hydrogen peroxide solution in a 100 ml beaker. Four different concentrations of hydrogen peroxide solution were used: 3%, 6%, 9% and 12% by weight. The blades were allowed to soak in the peroxide 20 solutions for various time periods. The blades were then removed from the solution and tested for sterility. The results of this testing are listed in Table 1 as a ratio of the number of inoculated blades which remain contaminated after treatment over the number of inoculated blades tested.

#### Table 1

Effect of H<sub>2</sub>O<sub>2</sub> Concentration and Soak Times on  
Sporicidal Activity of H<sub>2</sub>O<sub>2</sub> Solution

25

Soak Time	Concentration of H <sub>2</sub> O <sub>2</sub> Solution			
	3%	6%	9%	12%
1 min	4/4	4/4	4/4	4/4
5 min	4/4	4/4	4/4	4/4
30 min	4/4	4/4	4/4	4/4
60 min	4/4	4/4	4/4	4/4
90 min	N/D*	4/4	2/4	0/4
120 min	N/D	4/4	N/D	N/D

35 \* N/D - not determined

Complete sterilization was not effected until after the blades had been soaked in 12% hydrogen peroxide solution for at least 90 minutes. Moreover, none of the blades tested were sterilized after 2 hours in 6% hydrogen peroxide solution. It is clear from these data that contact with dilute hydrogen peroxide solution alone is ineffective at providing sterilization, unless extended soak times and concentrated solutions are used.

5 Testing was next performed to evaluate the effect on the sterilization of long, narrow lumens of a pretreatment step in which the lumens to be sterilized are exposed to hydrogen peroxide solution prior to exposure to a vacuum. The testing evaluated the efficacy of hydrogen peroxide vapor sterilization inside the lumens. The testing is detailed below in Example 2.

#### Example 2

10 A biological challenge consisting of  $1.9 \times 10^6$  *B. stearothermophilus* spores on a stainless steel scalpel blade was used. Some inoculated blades were pre-treated with a solution of aqueous hydrogen peroxide. Other inoculated blades, designated control blades, did not receive pretreatment with hydrogen peroxide. The pretreatment consisted of 5 minutes of static soaking in peroxide solution. The pre-treated blades were blotted dry, and each blade was then placed inside a stainless steel lumen, 3 mm internal diameter (ID) x 50 cm length. The lumen had a center piece of 1.3  
15 cm ID and 5 cm length. The pre-treated blade was placed inside this center piece, and additional hydrogen peroxide solution was added into the center piece in various amounts. Control blades were handled identically, except that they did not receive pretreatment with hydrogen peroxide solution. The lumens were placed in a vacuum chamber, and the chamber was evacuated to 1 Torr and held there for 15 minutes, during which time the temperature increased from approximately 23°C to approximately 28°C. Following exposure to the vacuum, the chamber was vented and the blades  
20 were removed from the chamber and tested for sterility. The results were as follows:

Table 2

Effect of Pretreatment and Hydrogen Peroxide Concentration  
on Sterilization of the Interior of Lumens

5

(A) With 1% hydrogen peroxide solution and vacuum

	Additional peroxide added into the center piece	Blades not pre-treated with peroxide	Blades pre-treated in peroxide solution
10	10 $\mu$ L	+	+
	20 $\mu$ L	+	+
	30 $\mu$ L	+	+
	40 $\mu$ L	+	+
	50 $\mu$ L	+	+
15	100 $\mu$ L	+	.
	150 $\mu$ L	+	.
	200 $\mu$ L	.	.
	250 $\mu$ L	.	.

20

(B) With 3% hydrogen peroxide solution and vacuum

	Additional peroxide added into the center piece	Blades not pretreated with peroxide	Blades pretreated in peroxide solution
25	10 $\mu$ L	.	.
	20 $\mu$ L	.	.
	30 $\mu$ L	.	.
	40 $\mu$ L	.	.
	50 $\mu$ L	.	.
30	100 $\mu$ L	.	.
	150 $\mu$ L	.	.
	200 $\mu$ L	.	.
	250 $\mu$ L	.	.

35

(C) With 6% hydrogen peroxide solution and vacuum

	Additional peroxide added into the center piece	Blades not pretreated with peroxide	Blades pretreated in peroxide solution
5	10µL	.	.
	20µL	.	.
	30µL	.	.
	40µL	.	.
10	50µL	.	.

As seen from these results, sterilization can be effected using relatively dilute solutions of peroxide and exposure to negative pressure. When the vacuum was applied, the peroxide added to the center piece of the lumen was vaporized and contacted the blade, which was sufficient to effect sterilization. It can be seen from these data that the pre-treatment increases effectiveness, but that pre-treatment is unnecessary as long as the peroxide diffuses from the inside to the outside.

Sterilization inside various lumen sizes after pretreatment with peroxide was compared with sterilization inside the lumens without the pretreatment step. This testing is detailed in Example 3.

**Example 3**

A biological challenge consisting of  $1.9 \times 10^8$  *B. stearotherophilus* spores on a stainless steel scalpel blade was used. Test A in Table 3 below consisted of the inoculated blades being pretreated with a solution of 3% aqueous hydrogen peroxide. The pretreatment consisted of 5 minutes of static soaking in the peroxide solution. The pretreated blades were blotted dry, then placed into the center piece of a stainless steel lumen which varied in size, together with 10 µl of 3% hydrogen peroxide solution. The center piece was 1.3 cm ID and 5 cm length. Test B in Table 3 below consisted of identically inoculated control blades which did not receive pretreatment with hydrogen peroxide. Each inoculated control blade was placed directly into the center piece of a stainless steel lumen together with 10 µl of 3% hydrogen peroxide solution. The center piece had dimensions identical to those in Test A. Lumens of various dimensions were used to evaluate the effect on sterilization of lumen internal diameter and length. The lumens were placed in a vacuum chamber, and the chamber was evacuated to 1 Torr for 15 minutes. During this 15 minutes of the sterilization cycle, the temperature increased from approximately 23°C to approximately 28°C. Following exposure to the vacuum, the chamber was vented and the blades were removed from the chamber and tested for sterility. The results are reported in Table 3, where "L/D Ratio" indicates the ratio of length to internal diameter.

Table 3

Effect of Pretreatment With Dilute Hydrogen Peroxide in Various Sized Lumens

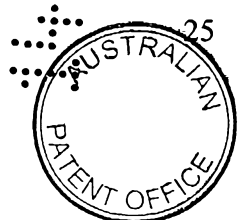
5

SS lumen size	L/D Ratio	Test A	Test B
1mm x 50 cm	500	-	-
1mm x 40 cm	400	-	-
1mm x 27 cm	270	-	-
1mm x 15 cm	150	-	-
3mm x 50 cm	166 <sup>2</sup> /3	-	-
3mm x 40 cm	133 <sup>1</sup> /3	-	-
3mm x 27 cm	90	-	+
3mm x 15 cm	50	+	+
6mm x 50 cm	83 <sup>1</sup> /3	-	-
6mm x 40 cm	66 <sup>2</sup> /3	-	-
6mm x 27 cm	45	+	+
6mm x 15 cm	25	+	+

10 All lumens having a L/D ratio greater than 50 which were tested under the conditions of Test A of Example 3 were sufficiently diffusion-restricted to be sterilized in this system. Thus, it is believed that other lumens having an L/D ratio greater than 50 should also provide a sufficient level of diffusion-restriction for sterilization in accordance with the present invention. This testing shows that, in direct contrast to prior art methods, sterility through diffusion of hydrogen peroxide vapor from inside the article to outside the article is easier to achieve in longer, narrower lumens than in shorter, wider lumens. This is believed to be due to the larger lumens allowing too much of the hydrogen peroxide vapor to diffuse out of the inside of the lumen during the sterilization process. Thus, the vapor does not contact the internal surfaces for a period of time sufficient or at a concentration sufficient to effect sterilization.

15 As discussed above, prior art methods of hydrogen peroxide vapor sterilization of lumens are generally limited to use on relatively short and wide lumens. In contrast to these prior art methods, the method of the present invention is effective on the interior of long, narrow lumens, including those longer than 27 cm in length and/or having an internal diameter of less than 3 mm.

20 To determine whether the ability of the sterilant vapor to diffuse within the system is a critical factor in achieving sterility, additional testing was performed to compare diffusion restricted and open, non-diffusion restricted systems. A non-diffusion restricted system is one in which the diffusion of vapors in and around the article is not restricted by narrow openings, long, narrow lumens, or the like. As used herein, "diffusion-restricted" is defined as referring to any one or more of the following properties: (1) the ability of an article placed within the sterilization system of the present



invention to retain 0.17 mg/L or more hydrogen peroxide solution after one hour at 40°C and 10 torr; (2) having the same or more diffusion restriction than provided by a single entry/exit port of 9 mm or less in internal diameter and 1 cm or greater in length; (3) having the same or more diffusion restriction than provided by a lumen 27 cm in length and having an internal diameter of 3 mm; (4) having the same or more diffusion restriction than provided by a lumen having a ratio of length to internal diameter greater than 50; (5) the ability of an article placed within the sterilization system of the present invention to retain 17% or more of the hydrogen peroxide solution placed therein after one hour at 40°C and 10 torr; or (6) being sufficiently diffusion-restricted to completely sterilize a stainless steel blade within a 2.2 cm by 60 cm glass tube having a rubber stopper with a 1 mm by 50 cm stainless steel exit tube therein at a vacuum of 10 torr for one hour at 40°C in accordance with the present invention. It is acknowledged that characteristics (1) and (5) will vary depending on the initial concentration of hydrogen peroxide placed into the article; however, this can be readily determined by one having ordinary skill in the art.

As discussed in the Background of the Invention, articles having diffusion restricted areas are difficult to sterilize using known methods of hydrogen peroxide vapor sterilization, since these methods are dependent upon the diffusion of peroxide vapors from outside the article to the interior of the article. Testing performed to evaluate the importance of sterilant vapor diffusion is described in Example 4.

#### Example 4

Hydrogen peroxide vapor sterilization was tested in both open and diffusion restricted systems. The open system consisted of stainless steel lumens having internal diameters of 1, 3, and 6 mm, and lengths of 15, 27, 40 and 50 cm. Stainless steel scalpel blades were inoculated with  $1.9 \times 10^8$  *B. stearothermophilus* spores, and the blades placed in the center piece of the lumen together with 10  $\mu$ l of 3% hydrogen peroxide solution. The dimensions of the center piece were 1.3 cm ID, 5 cm length and 6.6 cc volume.

The diffusion restricted system is illustrated in FIGURE 1. Identically inoculated scalpel blades were placed within the center pieces of lumens having dimensions identical to those described above. Ten  $\mu$ l of 3% hydrogen peroxide solution was also added to the center piece of the lumen. The lumen was then placed within a 2.2 cm x 60 cm glass tube. The tube was closed at one end, and the open end was plugged with a rubber stopper having a 1 mm x 10 cm stainless steel tube inserted through the stopper. Thus, gases entering or exiting the glass tube could pass only through this 1 mm x 10 cm opening.

The open lumen system and the diffusion restricted system were placed inside a vacuum chamber. The chamber was evacuated to 1 Torr pressure and held there for 15 minutes, during which time the temperature increased from approximately 23°C to approximately 28°C. The chamber was then vented, and the blades removed from the lumens and tested for sterility. The results are as follows:

Table 4

**Hydrogen Peroxide Vapor Sterilization  
in Open and Diffusion Restricted Systems**

5

System	Peroxide amount	Length	1mm ID	3mm ID	6mm ID
10 Open	10 $\mu$ L of 3%	50 cm	-	-	-
		40 cm	-	-	-
		27 cm	-	+	+
		15 cm	-	+	+
15 Diffusion Restricted Environment	10 $\mu$ L of 3%	50 cm	-	-	-
		40 cm	-	-	-
		27 cm	-	-	-
		15 cm	-	-	-

Under the test conditions of Example 4, sterilization was not achieved in the shorter, wider lumens in the open system without pre-treatment with hydrogen peroxide. Pre-treatment, and other test conditions, such as higher peroxide concentration or longer treatment time, would likely allow sterilization of the 27 cm  $\times$  3 mm lumen, which has an L/D ratio greater than 50. In the diffusion restricted system, the blades were sterilized in all sizes of lumens, using a 3% hydrogen peroxide solution.

These results indicate that providing a source of hydrogen peroxide within a diffusion restricted environment allows for complete sterilization within the system. It is the restriction of vapor diffusion in the system, not the length or internal diameter of the lumen *per se* that determines the efficacy of the hydrogen peroxide vapor sterilization. Again, however, these data show that, unlike the prior art methods of hydrogen peroxide vapor sterilization of lumens, the method of the present invention is effective even on non-diffusion-restricted articles when placed into a diffusion-restricted environment.

To further test the idea that restriction of the diffusion of vapor in a system affects the ability to sterilize the system, the following experiment was performed.

30

Example 5

A stainless steel scalpel blade 5 was placed within a 2.2 cm x 60 cm glass tube 20 which was closed at one end, as illustrated in FIGURE 2. Each blade 5 had been inoculated with  $1.9 \times 10^6$  *B. stearothermophilus* spores. For some of the testing, the glass tube 20 was left open at one end, providing an open system. To create a diffusion restricted environment, the open end of the glass tube 20 was sealed with a rubber stopper 25 having a 1 mm x 10 cm stainless steel tube 30 through its center. In both the open and diffusion restricted systems, hydrogen peroxide solution at a concentration of either 3% or 6% was added to the glass tube 20 in amounts of 50, 100, 150 or 200  $\mu$ l, together with the inoculated blade 5. The tube 20 was placed in a vacuum chamber, and the chamber evacuated



to 1 Torr for 15 minutes, during which time the temperature increased from approximately 23°C to approximately 28°C. The diffusion restricted system only was also tested at 1 Torr for 30 minutes, during which time the temperature increased from approximately 23°C to approximately 33°C. The vacuum chamber was then vented, and the blades 5 removed from the tube 20 and tested for sterility. The results are listed in Table 5 below.

5

Table 5

Hydrogen Peroxide Vapor Sterilization in  
Open and Diffusion Restricted Systems

10 Open System, 15 minutes vacuum at 1 Torr:

	50 $\mu$ L	100 $\mu$ L	150 $\mu$ L	200 $\mu$ L
3% peroxide	+	+	+	+
6% peroxide	+	+	+	+

15 Diffusion Restricted System, 15 minutes vacuum at 1 Torr:

	50 $\mu$ L	100 $\mu$ L	150 $\mu$ L	200 $\mu$ L
3% peroxide	+	.	.	.
6% peroxide	.	.	.	.

20 Diffusion Restricted System, 30 minutes vacuum at 1 Torr:

	50 $\mu$ L	100 $\mu$ L	150 $\mu$ L	200 $\mu$ L
3% peroxide	.	.	.	.

These results show that the addition of hydrogen peroxide solution, followed by exposure to vacuum, is  
25 ineffective for achieving rapid sterilization in an open system. Identical treatment in a diffusion restricted system, by comparison, results in complete sterilization, except at the very weakest concentration of hydrogen peroxide solution in an amount of only 50  $\mu$ L. Sterilization can be effected, however, by increasing the exposure to the vacuum.

Thus, the method of the present invention, wherein small amounts of hydrogen peroxide solution are delivered to the article to be sterilized prior to exposure to a vacuum, is an effective method of sterilization. The method does  
30 not depend on the diffusion of sterilant vapor into the article being sterilized. Rather, the hydrogen peroxide vapor is created by the vacuum within the system. This vapor is prevented from leaving the system too quickly, because the diffusion of the sterilant vapor from the inside of the article to the outside of the article is slowed. In a diffusion restricted environment, the vapor therefore contacts the article to be sterilized for a period of time sufficient to effect complete sterilization. In addition, unlike the prior art methods where the water in the peroxide solution is vaporized first  
35 and becomes a barrier to the penetration of the peroxide vapor, the method of the present invention removes any water from the system first, thereby concentrating the hydrogen peroxide vapor remaining in the system. More importantly, in the preferred method of the present invention, the diffusion of vapor is from the inside to outside rather than outside to inside as in the prior art. As a result, diffusion-restriction in the present invention serves to increase the effectiveness of sterilization rather than to decrease the effectiveness, as in the prior art.

To determine the effect of various pressures on a diffusion restricted sterilization system, the following experiment was performed.

Example 6

A stainless steel scalpel blade 5 was placed within a 2.2 cm x 60 cm glass tube 20 which was closed at one end, as shown in FIGURE 2. Each blade 5 had been inoculated with  $1.9 \times 10^6$  *B. stearothermophilus* spores. To create a diffusion restricted environment, the open end of the glass tube 20 was sealed with a rubber stopper 25 having a 1 mm x 10 cm stainless steel tube 30 through its center. Hydrogen peroxide solution at a concentration of 3% was added to the glass tube 20 in amounts of 50, 100, 150 or 200  $\mu$ L, together with the inoculated blade 5. The tube 20 was placed in a vacuum chamber, and subjected to various pressures for 15 minutes, during which time the temperature increased from approximately 23°C to approximately 28°C. In a further experiment to determine the effect of increased temperature on the system, the tube 20 was first heated to 45°C, then subjected to 50 Torr pressure for 15 minutes. The results were as follows.

Table 6

15 Effect of Temperature and Pressure on a Diffusion Restricted System

15 minutes vacuum with 3% hydrogen peroxide solution:

	50 $\mu$ L	100 $\mu$ L	150 $\mu$ L	200 $\mu$ L
20 1 torr pressure	+	.	.	.
5 torr pressure	.	.	.	.
10 torr pressure	.	.	.	.
15 torr pressure	.	.	.	.
20 torr pressure	.	.	.	.
25 torr pressure	.	.	.	.
25 30 torr pressure	+	+	+	+
35 torr pressure	+	+	+	+
40 torr pressure	+	+	+	+
45 torr pressure	+	+	+	+
30 50 torr pressure	+	+	+	+

15 minutes vacuum with 3% hydrogen peroxide at 45°C:

	50 $\mu$ L	100 $\mu$ L	150 $\mu$ L	200 $\mu$ L
35 50 torr pressure	.	.	.	.

These data show that sterilization can be achieved in diffusion restricted environments at pressures up to about 25 Torr at 28°C. At pressures of 30 Torr and higher, sterilization was not achieved; this is believed to be due to the

fact that the vapor pressure of hydrogen peroxide at 28°C is approximately 28 Torr. Thus, at higher pressures, the liquid hydrogen peroxide inside the glass tube was not vaporizing. This was confirmed by the testing done at 50 Torr pressure at 45°C, wherein sterilization was achieved. The vapor pressure of hydrogen peroxide is increased at 45°C, thus, the hydrogen peroxide was vaporized at 50 Torr, effectively sterilizing the blade placed inside the tube.

5 Accordingly, in order to achieve sterilization using the method of the present invention employing an aqueous solution of hydrogen peroxide, the temperature and pressure within the vacuum chamber should be such that vaporization of the aqueous hydrogen peroxide solution is achieved, i.e. the system should preferably be operated below the vapor pressure of the hydrogen peroxide. The pressure needs to be below the vapor pressure of hydrogen peroxide, such that the hydrogen peroxide solution present in the system is vaporized and diffuses from the interior of the diffusion restricted  
 10 environment to the outside. Alternatively, the hydrogen peroxide can be vaporized locally where the system remains above the vapor pressure by introducing energy to the site of the peroxide, such as through microwaves, radio waves, or other energy sources.

To further determine the effect of varying the pressure and the temperature in the diffusion restricted system described in Example 6, the following experiments were performed.

15 Example 7

A stainless steel scalpel blade 5 was placed within a 2.2 cm x 60 cm glass tube 20 which was closed at one end, as illustrated in FIGURE 2. Each blade 5 had been inoculated with  $1.9 \times 10^6$  *B. stearothermophilus* spores. To create a diffusion restricted environment, the open end of the glass tube 20 was sealed with a rubber stopper 25 having a 1 mm x 10 cm stainless steel tube 30 through its center. Hydrogen peroxide solution at a concentration of 3% was  
 20 added to the glass tube 20 in amounts of 50, 100, 150 or 200  $\mu$ l together with the inoculated blade 5. The tube 20 was placed in a vacuum chamber, and the chamber evacuated to 5 Torr. To vary the pressure within the chamber, the valve to the vacuum pump was closed, such that the pressure within the chamber rose from 5 Torr to 6.15 Torr after 15 minutes, during which time the temperature increased from approximately 23°C to approximately 28°C. In a second test, the tube 20 was placed in the chamber and the chamber was evacuated to 50 Torr. The temperature of the glass  
 25 tube 20 was increased to 45°C after the evacuation of the chamber was complete. The tube 20 was treated for 15 minutes. The results of these tests are reported below.

Table 7

Effect of Varying Temperature and Pressure on  
 Diffusion Restricted Sterilization System

Pressure increased from 5 Torr to 6.15 Torr:

35

	50 $\mu$ L	100 $\mu$ L	150 $\mu$ L	200 $\mu$ L
Efficacy Results	.	.	.	.

Temperature of the tube increased to 45°C:

	50 $\mu$ L	100 $\mu$ L	150 $\mu$ L	200 $\mu$ L
Efficacy Results	.	.	.	.

5

These results show that maintaining a constant pressure or temperature is not required in the diffusion restricted environment to effect sterilization. Under the conditions tested, the hydrogen peroxide is vaporized and kept in contact with the device to be sterilized for a time sufficient to effect complete sterilization.

The preferred method of the present invention relies on the delivery of liquid hydrogen peroxide to the article 10 to be sterilized prior to vacuum or plasma treatment. The following testing was performed to determine the effect of the location of the delivery of the hydrogen peroxide within the diffusion restricted environment.

Example 8

A stainless steel scalpel blade 5 was inoculated with  $1.9 \times 10^6$  *B. stearothermophilus* spores, and the blade 5 placed in the center piece 10 of a lumen 15 as illustrated in FIGURE 1. The dimensions of the center piece 10 were 15 1.3 cm ID, 5 cm length and 6.6 cc volume, while the lumen itself varied in size, having an ID of 1, 3 or 6 mm, and a length of 15, 27, 40 or 50 cm. The lumen 15 was placed within a 2.2 cm x 60 cm glass tube 20. The tube 20 was closed at one end, and the open end was plugged with a rubber stopper 25 having a 1 mm x 10 cm stainless steel tube 30 placed through the stopper 25. Thus, gases entering or exiting the glass tube 20 could pass only through this 1 mm x 10 cm opening. 10  $\mu$ l of 3% hydrogen peroxide solution was placed inside the lumen 15, or 100  $\mu$ l of 3% hydrogen 20 peroxide solution was placed inside the glass tube 20, but outside the stainless steel lumen 15. The glass tube 20 was then placed in a vacuum chamber, which was sealed and evacuated to 1 Torr for 15 minutes, during which time the temperature increased from approximately 23°C to approximately 28°C. Results of this testing are as follows.

Table 8

25

Effect of Hydrogen Peroxide Solution  
Placed Outside Inner Lumen

30

35

Peroxide amount	Length	1mm ID	3mm ID	6mm ID
10 $\mu$ L of 3% in lumen	50 cm	.	.	.
	40 cm	.	.	.
	27 cm	.	.	.
	15 cm	.	.	.
100 $\mu$ L of 3% in glass tube	50 cm	+	+	+
	40 cm	+	+	+
	27 cm	+	+	+
	15 cm	+	+	.

These data show that, under the test conditions of Example 8, sterilization did not occur within the inner lumen when the hydrogen peroxide solution was placed outside the lumen in a diffusion restricted environment, but that complete sterilization was effected when the hydrogen peroxide solution was placed inside all of the lumens in a diffusion restricted environment. When the hydrogen peroxide vapor must diffuse from outside to inside, the sterilant vapor cannot  
5 enter the inner lumen in a diffusion restricted environment unless the lumen is sufficiently large. Thus, when the hydrogen peroxide solution was placed outside the lumen, only the shortest, widest lumens allowed sufficient vapor penetration to allow sterilization inside the lumen. These data confirm that prior art methods which require diffusion of sterilant vapor from outside the article to the interior article cannot achieve sterilization in diffusion restricted environments under these conditions. In contrast, under the same conditions except where the hydrogen peroxide was  
10 placed inside the article, allowing hydrogen peroxide to diffuse from inside to outside, complete sterilization occurred with much lower amounts of hydrogen peroxide.

The method of the present invention is therefore useful in environments where diffusion of the sterilant vapor is limited. To evaluate the effect of changes in the amount of diffusion restriction within a diffusion restricted environment, the following testing was performed.

15

Example 9

A stainless steel scalpel blade 5 was inoculated with  $1.9 \times 10^6$  *B. stearothermophilus* spores, and placed in a 2.2 cm x 60 cm glass tube 20 as illustrated in FIGURE 2. The tube 20 was closed at one end, and the open end was plugged with a rubber stopper 25. Stainless steel tubing 30 of various dimensions was inserted through the stopper 25. Thus, gases entering or exiting the glass tube 20 could pass only through the opening in the tubing 30, which varied  
20 from 1 mm to 6 mm in diameter. Three percent hydrogen peroxide solution in volumes ranging from 50  $\mu$ L to 200  $\mu$ L was also placed inside the glass tube 20. The glass tube 20 was then placed in a vacuum chamber, which was sealed and evacuated to 5 Torr for 15 minutes, during which time the temperature increased from approximately 23°C to approximately 28°C. In addition, three lumens were tested at 10 Torr for 15 minutes with 3% hydrogen peroxide. The results of this testing are listed below in Table 9.

25

Table 9

## Effects of Tubing Dimension and Vacuum Pressure on Sterilization

5

15 minutes vacuum at 5 Torr with 3% hydrogen peroxide

SS tubing	50 $\mu$ L	100 $\mu$ L	150 $\mu$ L	200 $\mu$ L
1mm x 10cm	.	.	.	.
1mm x 5cm	.	.	.	.
10 1mm x 2.5cm	+	.	.	.
3mm x 10cm	.	.	.	.
3mm x 5cm	.	.	.	.
3mm x 2.5cm	+	.	.	.
6mm x 10cm	.	.	.	.
15 6mm x 5cm	+	.	.	.
6mm x 2.5cm	+	.	.	.

15 minutes vacuum at 10 Torr with 3% hydrogen peroxide

SS tubing	50 $\mu$ L
20 1mm x 2.5cm	.
3mm x 2.5cm	.
6mm x 2.5cm	.

Complete sterilization was achieved in the majority of the environments tested. Sterilization could not be achieved at 5 torr using the shortest length of stainless steel tubing and only 50  $\mu$ l hydrogen peroxide solution. Greater volumes of hydrogen peroxide must be used in these systems.

These data also confirm that the vacuum pressure affects sterilization efficacy, since the container with the shortest and widest exit tube could provide sterilization at 10 Torr, but not at 5 Torr. At too low pressures (such as pressures below 5 Torr in the conditions tested) however, it appears that the hydrogen peroxide vapor is pulled from the interior of the article being sterilized too quickly, resulting in an insufficient amount of hydrogen peroxide vapor being allowed to contact the interior of the device to effect sterilization. It would appear that although a pressure of 5 torr produces acceptable results, a pressure of approximately 10 Torr is better under the conditions tested.

The method of the present invention has been shown to be effective in diffusion restricted environments of metal and glass. To evaluate whether the method is effective in diffusion restricted environments formed of other materials, the experiments described in Examples 10 and 11 were performed.

Example 10

For this testing, a diffusion restricted system was tested.  $1.2 \times 10^6$  *B. stearothermophilus* spores were inoculated onto non-woven polypropylene pieces. As illustrated in FIGURE 1, the inoculated pieces 5 were placed inside the center piece 10 of a plastic lumen 15, together with 10  $\mu$ l of 3% hydrogen peroxide solution. The center piece 10 was made of Teflon™ and had dimensions of 1.3 cm x 5 cm. The lumen 15 varied from 1 mm to 6 mm ID, and 15 cm to 50 cm in length. Teflon™ was used for the 1 mm lumen, polyethylene was used for the 3 mm and 6 mm lumen. The lumen 15 was then placed within a 2.2 cm x 60 cm glass tube 20. The glass tube 20 was closed on one end, and the open end was sealed with a rubber stopper 25 having a 1 mm x 10 cm piece of PTFE tubing 30 through it. The glass tube 20 was placed in the vacuum chamber and treated for 15 minutes at 1 Torr, during which time the temperature increased from approximately 23°C to approximately 28°C. The results of this testing are set forth below.

Table 10A

Sterilization in Diffusion Restricted Systems  
Using Plastic Lumens

15

20

System	Pressure	Length	1mm ID	3mm ID	6mm ID
Diffusion Restricted System	1 torr	50 cm	.	.	.
		40 cm	.	.	.
		27 cm	.	.	.
		15 cm	.	.	.

Sterilization in diffusion restricted environments can be effected in both short, wide lumens and long, narrow lumens, regardless of whether metal or plastic is used to form the lumens. Thus, the method of the present invention is an effective sterilization method for diffusion restricted articles, and can be used on a wide variety of such articles, regardless of their composition.

To further confirm this,  $2.1 \times 10^6$  *B. stearothermophilus* spores were inoculated on stainless steel blades, and  $1.2 \times 10^6$  *B. stearothermophilus* spores were inoculated onto non-woven polypropylene pieces. As shown in FIGURE 2, the blades 5 or non-woven polypropylene pieces 5 were placed inside a 2.2 cm x 60 cm glass tube 20 together with 50  $\mu$ l of 3% hydrogen peroxide solution. One end of the tube was closed, and the open end was sealed with a rubber stopper 25 having either a 1 mm x 10 cm stainless steel tube 30 therein, or a 1 mm x 10 cm piece of Teflon™ tubing 30 therein. The glass tube 20 was placed inside a vacuum chamber and treated for 15 minutes at 5 Torr, during which time the temperature increased from approximately 23°C to approximately 28°C. The results are as follows.

Table 10B

Effect of Metal and Plastic on Sterilization  
in a Diffusion Restricted System

5

	SS tubing	Teflon tubing
Metal blade	.	.
Polypropylene	.	.

10 Thus, all four combinations of metal and plastic provide for effective hydrogen peroxide vapor sterilization in a diffusion restricted environment. This testing confirms that the method of the present invention is an effective sterilization method for diffusion restricted articles, and can be used on a wide variety of such articles, regardless of the materials used to form them.

Further testing was next performed to evaluate the effect of various temperatures and pressures on the  
15 sterilization of a diffusion restricted system. The testing is described below.

Example 11

Stainless steel blades were inoculated with  $2.1 \times 10^6$  *B. stearothermophilus* spores. The blades 5 were placed inside a 2.2 cm x 60 cm glass tube 20 as illustrated in FIGURE 2, along with various amounts of 3% hydrogen peroxide solution. The glass tube 20 was placed in a vacuum chamber and subjected to different pressures and different  
20 temperatures for various periods of time. During the sterilization cycles reported in Table 11A, the temperature increased from approximately 23°C to the temperatures indicated. In the experiments reported in Table 11B, the chamber was heated to approximately 45°C. In an alternative embodiment, rather than heating the chamber, the temperature of the peroxide solution itself can be heated. In the experiments reported in Table 11C, the temperature increased from approximately 23°C to approximately 28°C during the 15 minute period of exposure to vacuum.

25

Table 11A

Effect of Time and Volume of Peroxide on  
Sterilization in a Diffusion Restricted Environment

30 At 5 Torr pressure:

	5 min. (approx. 24°C)	10 min. (approx. 26°C)	15 min. (approx. 28°C)
50 $\mu$ L of 3% peroxide	.	.	.
100 $\mu$ L of 3% peroxide	.	.	.
150 $\mu$ L of 3% peroxide	+	.	.
35 200 $\mu$ L of 3% peroxide	+	.	.



Table 11B

Effect of Elevated Chamber Temperature and Volume of Peroxide on Sterilization in a Diffusion Restricted Environment

5

Chamber at approximately 45°C:

	5 min.
150 $\mu$ L of 3% peroxide	-
200 $\mu$ L of 3% peroxide	-

10

Table 11C

Effect of Pressure and Volume of Peroxide on Sterilization in a Diffusion Restricted Environment

15

With 15 minutes exposure time:

Approx. 28°C	1 torr	5 torr	10 torr
20 $\mu$ L of 3% peroxide	N/D	+	-
50 $\mu$ L of 3% peroxide	+	-	-
100 $\mu$ L of 3% peroxide	-	-	-

20

Under the test conditions of Example 11, large volumes of hydrogen peroxide solution were ineffective at achieving sterilization when vacuum was applied for only very short periods of time. This is believed to be at least partially because water vaporizes more quickly than hydrogen peroxide. Thus, the water present in the aqueous solution will vaporize first, and more time is needed to vaporize the hydrogen peroxide. This also explains why the larger volumes of hydrogen peroxide solution were effective at achieving sterilization at higher temperatures; the vaporization of the hydrogen peroxide occurs sooner at higher temperatures. Thus, when more water is present in the system, either higher temperatures or more time is required to achieve sterilization.

30

Again, it would appear from these data that slightly higher pressures, i.e. 10 Torr, achieve more effective sterilization under these conditions. This is believed to be because at higher pressures, more hydrogen peroxide vapor is retained inside the system. At too low a pressure, the hydrogen peroxide vapor is pulled out of the system too quickly.

In order to evaluate a putative minimum concentration of peroxide in the liquid/vacuum system in a diffusion-restricted container, Example 12 was carried out.

35

#### Example 12

Various concentrations of peroxide were used in a system substantially as described in connection with Figure 2. In this system, the exit tube 35 was a stainless steel tube having a length of 50 cm and an internal diameter of 1 mm. A stainless steel blade inoculated with  $1.9 \times 10^6$  spores of *B. stearotherophilus* was placed within the container which was a 2.2 cm  $\times$  60 cm glass tube. Various amounts of 3% hydrogen peroxide were introduced into the container. The

40

container was placed in a vacuum chamber of 173 liters, and the pressure reduced to 10 Torr for a period of one hour, during which time the temperature increased from approximately 23°C to approximately 40°C. Sporidical activity was evaluated at each concentration of peroxide. In addition, the amount of peroxide remaining in the container after the sterilization process was evaluated by standard titration techniques, whereby the peroxide was reacted with potassium iodide and titrated with sodium thiosulfate. Results are shown in Table 12 where "N/D" indicates not determined.

Table 12

Amount of Peroxide in Glass Tube	Sporicidal Activity	Remaining Peroxide
0.5 mg/L liquid	+	N/D
0.6 mg/L liquid	+	N/D
0.7 mg/L liquid	+	N/D
0.8 mg/L liquid	+	N/D
0.9 mg/L liquid	+	N/D
1.0 mg/L liquid	-	0.17 mg/L

The results reported in Table 12 indicate that 1.0 mg/L of 3% liquid peroxide were required in the system tested to effect sterilization. Further, under the conditions tested, a concentration of 0.17 mg/L of peroxide remaining in the system was sufficient to provide complete sterilization. These data also show that the glass tube used in these experiments provided a sufficient level of diffusion restriction to retain 17% of the hydrogen peroxide placed therein.

We further investigated the effects of length and internal diameter of the exit tube used in a system similar to that of Example 12. This testing is shown in Example 13.

Example 13

A system similar to that described above in connection with Example 12, with the exception that 15 minutes of vacuum rather than one hour was used. Thus, the temperature increased only to about 28°C. In this testing, the size of the exit tube was varied, as well as the volume of 3% peroxide solution. The results are reported below in Table 13.

Table 13

	50 $\mu$ l	100 $\mu$ l	150 $\mu$ l	200 $\mu$ l
Open without tubing	+	+	+	+
6 mm ID $\times$ 1 cm length	+	-	-	-
9 mm ID $\times$ 1 cm length	+	-	-	-
13 mm ID $\times$ 1 cm length	+	+	+	+

The results show that provided sufficient peroxide is present, the diffusion-restriction provided by a single entry/exit port of 9 mm or less in internal diameter, or 1 cm or greater in length is sufficient to effect sterilization.

To further evaluate the effect on sterilization efficacy of changes in the amount of restriction of vapor diffusion in the system, the following testing was performed.

5

Example 14

A stainless steel blade was inoculated with  $2.1 \times 10^6$  *B. stearothermophilus* spores. The blade 5 was placed inside a 2.2 cm x 60 cm glass tube 20 as shown in FIGURE 3, together with various amounts of 3% hydrogen peroxide solution. One end of the tube was closed, and the open end was sealed with a rubber stopper 25 having a syringe filter 35 inserted therein. The glass tube 20 was placed inside a vacuum chamber and treated for 15 minutes at 5 Torr, 10 during which time the temperature increased from approximately 23°C to approximately 28°C. As a control, identically inoculated blades were placed inside 2.2 cm x 60 cm glass tubes. The open end of the tubes was left open, no stopper or syringe filter was used. Thus, the diffusion of vapor from the interior of the tube was not restricted.

Various syringe filters having various pore sizes were tested, including MFS PTFE 25 mm syringe filters with a 0.2  $\mu\text{m}$  membrane filter and a 0.5  $\mu\text{m}$  membrane filter; a Nalgene PTFE 50 mm syringe filter with a 0.2  $\mu\text{m}$  membrane 15 filter and a 0.45  $\mu\text{m}$  membrane filter; a Whatman Anotop™ 10 Plus sterile syringe filter with a 0.02  $\mu\text{m}$  membrane filter and a 0.1  $\mu\text{m}$  membrane filter; and finally, a Gelman Acrodisc™ CR PTFE syringe filter with a 0.2  $\mu\text{m}$ , 0.45  $\mu\text{m}$ , and a 1.0  $\mu\text{m}$  membrane. The results are as follows.

Table 14

20

**Sporicidal Activity of H<sub>2</sub>O<sub>2</sub> Solution with Vacuum  
in a Container Having a Syringe Filter**

15 minutes vacuum and 3% hydrogen peroxide:

25

(a) Without syringe filter and stopper:

	50 $\mu\text{L}$	100 $\mu\text{L}$	150 $\mu\text{L}$	200 $\mu\text{L}$
5 Torr	+	+	+	+
10 Torr	+	+	+	+

30

(b) With MFS™ PTFE 25 mm syringe filter:

(1) 0.2  $\mu\text{m}$  membrane filter

35

	50 $\mu\text{L}$	100 $\mu\text{L}$	150 $\mu\text{L}$	200 $\mu\text{L}$
5 Torr	+	-	-	-
10 Torr	-	-	-	-

(2) 0.5  $\mu\text{m}$  membrane filter

	50 $\mu\text{L}$	100 $\mu\text{L}$	150 $\mu\text{L}$	200 $\mu\text{L}$
5 Torr	+	.	.	.
10 Torr	.	.	.	.

5

(3) With 2 MFS™ filters together at 5 Torr pressure

	50 $\mu\text{L}$
Two 0.2 $\mu\text{m}$ filters	.
Two 0.5 $\mu\text{m}$ filters	.

10

(c) With Nalgene™ PTFE 50 mm syringe filter:

(1) 0.2  $\mu\text{m}$  membrane filter

	50 $\mu\text{L}$	100 $\mu\text{L}$	150 $\mu\text{L}$	200 $\mu\text{L}$
5 Torr	.	.	.	.
10 Torr	.	.	.	.

15

(2) 0.45  $\mu\text{m}$  membrane filter

	50 $\mu\text{L}$	100 $\mu\text{L}$	150 $\mu\text{L}$	200 $\mu\text{L}$
5 Torr	.	.	.	.
10 Torr	.	.	.	.

20

(d) With Whatman Anotop™ 10 Plus syringe filter:

(1) 0.02  $\mu\text{m}$  membrane filter

	50 $\mu\text{L}$	100 $\mu\text{L}$
5 Torr	.	.
10 Torr	.	.

30

(2) 0.1  $\mu\text{m}$  membrane filter

	50 $\mu\text{L}$	100 $\mu\text{L}$
5 Torr	.	.
10 Torr	.	.

35

(e) With Gelman Acrodisc™ CR PTFE syringe filter:

(1) 0.2 μm membrane filter

		50 μL	100 μL
5	5 Torr	+	-
	10 Torr	-	-

(2) 0.45 μm membrane filter

		50 μL	100 μL
10	5 Torr	+	-
	10 Torr	-	-

(3) 1.0 μm membrane filter

		50 μL	100 μL
15	5 Torr	+	-
	10 Torr	-	-

As is apparent from these results, certain brands of filters do not create a sufficiently diffusion restricted environment at 5 Torr pressure when only 50 μL of hydrogen peroxide solution is placed in the system. Other brands of filters did provide sufficient diffusion restriction; these brands of filters had either longer lumens or smaller filter pore size. Using larger volumes of peroxide solution, 10 Torr pressure, or serial filters enhances the efficacy of the sterilization system. This is important, as filters, including ones made of Tyvek™, are often used in packaging of sterile articles to prevent re-contamination with bacteria. These filters generally have a pore size of 1 μm or less, or in the case of Tyvek™, create a tortuous path which bacteria cannot cross. In the present invention, filters can be used in combination with other packaging means to create a diffusion restricted environment to effect sterilization, and the sterile article can remain inside the packaging during storage prior to use; the filter will prevent re-contamination of the sterile article.

FIGURE 4 is a cross-sectional illustration of one embodiment of a diffusion restricted environment represented by a container having a limited diffusion port or communication port consisting of tubing. This communication port may have an air permeable microorganism barrier such as a filter in order to maintain a sterility of the devices and the exterior of the lumen device can be sterilized with the peroxide vapor generated from the source of peroxide within the container. In one method of efficiently sterilizing the interior of the lumen device, the peroxide vapor needs to be generated within the lumen device. Therefore, the lumen device needs to be pre-treated with liquid peroxide.

FIGURES 5-6 illustrate other embodiments of the present invention employing other packaging means to create a diffusion-restricted environment to effect sterilization. Another approach can be used to sterilize the interior of lumen device 15 without pre-treating the interior of lumen device 15 with the source of peroxide. In order to flow the peroxide

vapor generated inside container 20 through the interior of lumen device 15, a connector can be used to connect the lumen device 15 to the communication port 30 of the container 20. FIGURES 5A and 5B illustrate this approach. FIGURE 5A is a cross-sectional illustration of one embodiment of a diffusion restricted environment represented by a container 20 having a limited diffusion port or communication port 30, consisting of tubing, and a tubing connector 45 to connect a lumen device 15 to the communication port 30 of the container 20. FIGURE 5B is a cross-sectional illustration of one embodiment of a diffusion restricted environment represented by a container 20 having a limited diffusion port (communication port 30 consisting of tubing) and an enclosure connector 50 to connect a lumen device 15 to the communication port 30 of the container 20. The enclosure connector 50 has an interface 51 between the container 20 and the enclosure connector 50. This interface 51 can be constructed in several different ways so as to allow a portion of the lumen device 15 to be inserted into the connector enclosure 50, while maintaining an air and vapor pressure seal between parts 15 and 50. One way to achieve this is with a camera shutter approach employing an iris diaphragm, such as a precision iris diaphragm from Edmund Scientific . An optional spring can be used to insure the closure of the shutter. Another way to achieve an acceptable interface is to employ two plates, wherein the area between the two plates has a compressible material, such as a rubber material. The lumen device 15 can be placed between the two plates and the two plates moved together to form a gas and vapor impermeable seal around the lumen device 15. Optionally, a porous material like a sponge or air permeable material may be utilized for the compressible material. In this case, some vapor sterilant can diffuse between the compressible material and the lumen device. However, most of the sterilant vapor is forced to diffuse through the lumen device. Yet another way to achieve an acceptable interface is to employ a hole or horizontal opening for one or more lumen devices 15, said hole or opening being a gas or liquid inflatable port. Thus, the connector can be a tubing adapter 45 which can be attached to the lumen device 15 or an enclosure 50 which contains a portion of the lumen device 15. Since one of the openings of the lumen device 15 is connected to the communication port 30 with the connector 45 or 50, the vaporized peroxide has to be evacuated through the lumen device 15. Tubing connector 45 can be constructed of any materials such as silicone, teflon, etc. which meet the thermal, pressure, gas and vapor compatibility requirements of the system. These same considerations apply to materials utilized for other parts illustrated herein. Note that the limited diffusion port can be created by either the communication port 30 or the lumen device 15.

FIGURE 6 illustrates another possible arrangement. FIGURE 6 is a cross-sectional illustration of one embodiment of a diffusion restricted environment represented by a container 20 having a communication port 30 consisting of a window with an air permeable barrier and an enclosure connector 50 to connect a lumen device 15 to the window 30. In this embodiment, the lumen device 15 is connected to the connector 50 and is used as the device to create the diffusion restricted area in the container 20. Therefore, the communication port 30 in FIGURES 4, 5A and 5B can be replaced with an air permeable window 30 if desired. This porous window 30 allows the diffusion of air and vapor, but prevents microorganisms from outside from contaminating the sterilized instruments 15 or 40 in the container or pouch 20. Under the reduced pressure environment, the peroxide vapor is first generated in the container or pouch 20 and then diffuses through the lumen device 15 into the connector 50. The entire connector 50 can be made of air permeable material. FIGURE 6 additionally illustrates how the reduced pressure is to be achieved. This is achieved via a port 55

in the vacuum chamber 65, said port being connected to a vacuum pump 60 to produce the reduced pressure environment. In order to test whether other sterilants can also be used to effect sterilization in diffusion restricted environments, the following testing was performed.

Example 15

5 A stainless steel blade was inoculated with  $1.9 \times 10^6$  *B. stearothermophilus* spores. The blade 5 was placed inside a 2.2 cm x 60 cm glass tube 20 as shown in FIGURE 2, along with various amounts of 4.74% peracetic acid solution (Solvay Interlox Ltd., Warrington, England). The glass tube 20 was placed in a vacuum chamber and subjected to 5 Torr pressure for 15 minutes, during which time the temperature increased from approximately 23°C to approximately 28°C. The results of this testing is shown below.

10

Table 15

Sterilization With Peracetic Acid in  
a Diffusion Restricted System

	50 $\mu$ L	100 $\mu$ L	150 $\mu$ L	200 $\mu$ L
Efficacy Results	-	-	-	-

These results show that peracetic acid, in which hydrogen peroxide coexists, can also be used in the sterilization method of the present invention.

20 It was discovered that by delivering small amounts of hydrogen peroxide solution to an article to be sterilized prior to exposure to vacuum, sterilization could be effected at lower temperatures and in short periods of time. The following testing was performed to evaluate different methods of delivering hydrogen peroxide solution to the article to be sterilized. Further, the efficacy of vacuum treatment and plasma treatment following pretreatment with aqueous hydrogen peroxide were compared. The testing is described in Example 16 below.

25

Example 16

In a first series of tests, stainless steel blades were inoculated with  $2.5 \times 10^8$  *B. stearothermophilus* spores. The blades were placed in the expanded center piece of a 3 mm x 50 cm stainless steel lumen. The lumen was placed in a 1000 ml beaker containing 800 ml of hydrogen peroxide solution. The lumen was soaked for 5 minutes in 3% hydrogen peroxide solution. The number of surviving organisms following this initial soak was determined. The lumens  
30 were removed from the hydrogen peroxide solution and the outside blotted dry with paper towels. The inside of the lumens were dried by placing one end of the lumen into a flask and blowing with a three second burst of compressed air. The lumens were shaken, and the blowing and shaking repeated until no more solution was blown out. Subsequently, the lumen was placed in a sterilization chamber and exposed to either a vacuum of 0.5 Torr for 15 minutes, or plasma for 15 minutes at 0.5 Torr. After 15 minutes of vacuum, the temperature increased from  
35 approximately 23°C to approximately 28°C. The results are set forth below in Table 16A.

**Table 16A**

**Effect of H<sub>2</sub>O<sub>2</sub> Solution Soak on  
Sporicidal Activity in Stainless Steel Lumens Prior to  
Either a Plasma or a Vacuum Treatment**

5

Conc. H <sub>2</sub> O <sub>2</sub> (%) Soak Time 5 min	Number of Surviving Organisms After Soaking Alone	Sterility Test Results		
		Soak Alone	Soak + Vacuum	Soak + Plasma
3.0	8.2x10 <sup>5</sup>	4/4	0/4	0/4

10

A five minute soak in 3% hydrogen peroxide solution was an effective means for delivering the hydrogen peroxide into the lumen prior to vacuum or plasma treatment. As noted before, treatment with hydrogen peroxide solution only is ineffective to achieve sterilization using dilute solutions and short soak times. Delivery of hydrogen peroxide solution via static soaking is at least as effective a way to deliver the hydrogen peroxide as depositing small volumes directly into the lumen of the device.

Flow-through delivery of hydrogen peroxide was tested next. Here, stainless steel blades were inoculated with 2.5 × 10<sup>8</sup> *B. stearothermophilus* spores. The blades were placed in the expanded center piece of a 3 mm x 50 cm stainless steel lumen. Hydrogen peroxide solution at 3% concentration was delivered to the lumen at a flow rate of 0.1 L/min, using a peristaltic pump. The lumen was dried as described above. Following pretreatment with hydrogen peroxide solution, the lumen was then placed in a sterilization chamber and exposed to either a vacuum of 0.5 Torr for 15 minutes, or plasma for 15 minutes at 0.5 Torr. The results are set forth below in Table 16B.

20

**Table 16B**

**Effects of Flow-Through Delivery of H<sub>2</sub>O<sub>2</sub> Solution on  
Sporicidal Activity Prior to Either a Vacuum or a Plasma  
Treatment in Stainless Steel Lumens**

25

Conc. H <sub>2</sub> O <sub>2</sub> (%) 5 min flow	Number of Surviving Organisms after Flow Alone	Sterility Test Results	
		Flow + Vacuum	Flow + Plasma
3	6.2x10 <sup>5</sup>	0/4	0/4

30

Delivery of the hydrogen peroxide solution via constant flow is also an effective way to deliver hydrogen peroxide to the system.

35

Finally, the effect of delivery of hydrogen peroxide by aerosol spray was tested. Stainless steel blades were inoculated with 2.5 × 10<sup>8</sup> *B. stearothermophilus* spores. The inoculated blades were placed in the expanded center piece of a 3 mm x 50 cm stainless steel lumen. Three percent hydrogen peroxide solution was delivered to the lumen via a 3 second aerosol spray. Aerosol spray rate was determined to be 0.04 L/min. After a 5 minute wait following

40



pretreatment with hydrogen peroxide, the lumen was dried as described above and the lumen was then placed in a sterilization chamber and exposed to either a vacuum of 0.5 Torr for 15 minutes, or plasma for 15 minutes at 0.5 Torr. The results are set forth below in Table 16C.

Table 16C

5

Effects of Aerosol Delivery of H<sub>2</sub>O<sub>2</sub> Solution on Sporocidal Activity Prior to Either a Vacuum or a Plasma Treatment in Metal Lumens

10

Conc. H <sub>2</sub> O <sub>2</sub> (%)	Number of Surviving Organisms after Aerosol Alone	Sterility Test Results	
		Aerosol + Vacuum	Aerosol + Plasma
3	7.4x10 <sup>5</sup>	0/4	0/4

15

Flow-through of hydrogen peroxide as either a liquid solution or aerosol can also be achieved by introducing increased pressure at the delivery end or decreased pressure at the exit end of the device to be treated.

It is evident from the data in Tables 16A-16C that all three methods of delivering hydrogen peroxide solution to the article to be sterilized provided for effective sterilization. Thus, it appears that a number of different methods of delivery can be used, as long as the hydrogen peroxide solution is present in the system prior to exposure to vacuum or plasma.

20

Finally, the efficacy of pretreatment with hydrogen peroxide prior to a sterilization cycle which combines exposure to hydrogen peroxide vapor, vacuum, and plasma was evaluated. The testing was as follows.

Example 17

Stainless steel blades were inoculated with 2.5 × 10<sup>8</sup> *B. stearothermophilus* spores. The blades were soaked in 3% hydrogen peroxide solution for either 1 or 5 minutes. The blades were then placed in the expanded center piece of a 3 mm x 50 cm stainless steel lumen. The lumen was then placed in a sterilization chamber which was evacuated to approximately 0.5 Torr. The sterilization cycle consisted of 15 minutes of hydrogen peroxide vapor diffusion with a minimum of 6 mg/L hydrogen peroxide, followed by 15 minutes of plasma at 400 watts. Following the plasma treatment, the chamber was vented and the blades tested for sterility. The results are shown below.

30

Table 17

Effects of H<sub>2</sub>O<sub>2</sub> Solution Soak on Sporocidal Activity in Stainless Steel Lumens Prior to a Hydrogen Peroxide Vapor and Plasma Cycle

35

Conc. H <sub>2</sub> O <sub>2</sub>	Soak Time	Sterility Test Results	
		Soak Alone	Soak + Cycle
3%	1 min	4/4	0/4
	5 min	4/4	0/4

Processing the lumens in a hydrogen peroxide vapor and plasma cycle alone left an average of 30 surviving organisms per blade. Pre-treating the blades by soaking in 3% hydrogen peroxide solution for 5 minutes alone left an average of  $8.2 \times 10^5$  surviving organisms per blade. Thus, under these particular test conditions, a combination of hydrogen peroxide vapor exposure and plasma exposure, which has been found to be effective for many articles, was 5 ineffective in a diffusion restricted environment. However, by pre-treating the article to be sterilized with dilute hydrogen peroxide solution prior to exposure to hydrogen peroxide vapor and plasma, complete sterilization can be achieved.

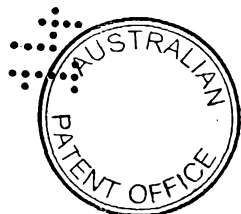
While the invention has been described in connection with preferred liquid sterilant solutions containing hydrogen peroxide, it will be appreciated by those having ordinary skill in the art that equivalent sterilization methods can be adapted for other sources of peroxide sterilants. In an alternative embodiment, a sterilant having a vapor pressure lower 10 than that of water or other solvent in which the sterilant may be provided is used. For such sterilants, it is only important that the vapor pressure be lower than that of the solvent within the temperature ranges contemplated herein. In yet other embodiments, a solid source of peroxide sterilant may be utilized. Such liquid and solid sterilants can be adapted for the techniques described herein with only minor adjustments made for the differences in vapor pressure between hydrogen peroxide and such other sterilant, as can be readily determined by those having ordinary skill in the 15 art. As long as the local vapor pressure at the site of the sterilant is below the vapor pressure of the sterilant, sterilization can be achieved substantially as described hereinabove.

#### Conclusion

Achieving rapid sterilization of lumened devices at low temperatures using low concentrations of sterilants has, until now, been exceedingly challenging. A superior method of sterilization has been discovered which overcomes the 20 problems of the known methods. By pre-treating articles to be sterilized or a diffusion-restricted environment containing the articles with a source of peroxide such as an aqueous solution of hydrogen peroxide prior to exposure to a vacuum, rapid sterilization can be achieved at low temperatures, without damage to the articles, without leaving toxic residues behind, and without the need to attach special vessels. The method of the present invention is efficient, nonhazardous, and inexpensive as well.

**The Claims defining the invention are as follows:**

1. A method for sterilizing an interior of an article with a diffusion restricted area, as hereinbefore defined, comprising:
  - 5       contacting the interior of said diffusion restricted area with a source of hydrogen peroxide or peracetic acid; and
  - exposing said device to negative pressure for a time period sufficient to effect complete sterilization of said diffusion restricted area.
2. The method of Claim 1, wherein said source of hydrogen peroxide or peracetic acid comprises a liquid or condensed vapor.
- 10   3. The method of Claim 1, wherein said contacting step comprises delivery via one or more methods selected from the group consisting of injection, static soak, liquid flow-through, aerosol spray, condensation or physical placement.
4. The method of Claim 1, wherein said area is a lumen.
5. The method of Claim 4, wherein said lumen is at least 27 cm in length and has an internal
  - 15       diameter of no more than 3 mm.
6. The method of Claim 4, wherein said lumen is at least 27 cm in length and has an internal diameter of no more than 1 mm.
7. The method of Claim 1, further comprising the step of exposing said article to a plasma during the step of exposing the article to negative pressure.
- 20   8. The method of Claim 7, wherein said method is performed within a first chamber and wherein said plasma is generated in a second, separate chamber and said method further comprises the step of flowing said plasma into said first chamber.
9. The method of Claim 7, wherein said method is performed within a sealed chamber and said plasma is generated within said chamber.
- 25   10. The method of Claim 1, wherein if the exposing step is conducted at 40°C and 10 torr for one hour and the source of peroxide comprises 1 mg/L of hydrogen peroxide, said diffusion restricted area is sufficiently diffusion restricted to retain 0.17 mg/L or more hydrogen peroxide after the exposing step.
11. The method of Claim 1, wherein said area has the same or more diffusion restriction than provided by a lumen 27 cm in length and an internal diameter of 3 mm.
- 30   12. The method of Claim 1, wherein said area has the same or more diffusion restriction than provided by a lumen having a ratio of length to internal diameter greater than 50.
13. The method of Claim 1, wherein if the exposing step is conducted at 40°C and 10 torr for one hour and the source of peroxide comprises 1 mg/L of hydrogen peroxide, said diffusion



restricted area is sufficiently diffusion restricted to retain 17% or more of the hydrogen peroxide placed therein after the exposing step.

14. The method of Claim 1, wherein the contacting step is repeated one or more times.

15. The method of claim 1, wherein the exposing step is repeated one or more times.

5 16. The method of claim 1, wherein both the contacting step and the exposing step are repeated one or more times.

17. The method of Claim 1, wherein said source of hydrogen peroxide or peracetic acid is at a concentration of less than 25% by weight.

18. The method of Claim 1, wherein said exposing step is performed for 60 minutes or less.

10 19. The method of Claim 1, further comprising the step of heating said article during said exposing step.

20. The method of Claim 1, wherein said exposing step occurs within a chamber, and wherein said method further comprises the step of heating said chamber during said exposing step.

15 21. The method of Claim 20, wherein said chamber is heated to between about 40°C and about 45°C.

22. The method of Claim 1, additionally comprising heating said source of hydrogen peroxide or peracetic acid prior to said contacting step.

23. The method of Claim 22, wherein said source of hydrogen peroxide or peracetic acid is heated to between about 40°C and about 45°C.

20 24. The method of Claim 1, wherein said exposing step comprises exposing said article to pressure less than the vapor pressure of hydrogen peroxide.

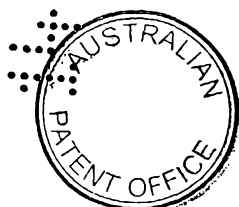
25. The method of Claim 24, wherein said pressure is between 0 and 100 torr.

26. The method of Claim 25, wherein said pressure is approximately 10 torr and the exposing step is conducted at a temperature of approximately 23°C to approximately 28°C.

25 27. A method for sterilizing an interior and an exterior of an article, comprising:  
 contacting said article with a source of hydrogen peroxide or peracetic acid; and  
 placing said article in a diffusion-restricted environment as hereinbefore defined, said contacting and placing steps being performed in either order; followed by  
 exposing said diffusion-restricted environment to negative pressure for a time period  
 30 sufficient to effect complete sterilization.

28. The method of Claim 27, wherein said source of hydrogen peroxide or peracetic acid comprises a liquid or condensed vapor.

29. The method of Claim 27, wherein the contacting step is performed before the placing step.



30. The method of Claim 29, additionally comprising contacting the article with a source of hydrogen peroxide or peracetic acid again after the placing step.

31. The method of Claim 27, additionally comprising heating said source of hydrogen peroxide or peracetic acid prior to said contacting step.

5 32. The method of Claim 27, wherein said exposing step occurs within a chamber, and wherein said method further comprises the step of heating said chamber during said exposing step.

33. The method of Claim 27, wherein if the exposing step is conducted at 40°C and 10 torr for one hour and a source of peroxide comprising 1 mg/L of hydrogen peroxide is introduced, said diffusion restricted environment is sufficiently diffusion restricted to retain 17% or more of the hydrogen peroxide placed therein after the exposing step.

34. The method of Claim 27, wherein if the exposing step is conducted at 40°C and 10 torr for one hour and a source of peroxide comprising 1 mg/L of hydrogen peroxide is introduced, said diffusion restricted environment is sufficiently diffusion restricted to retain 0.17 mg/L or more hydrogen peroxide after the exposing step.

15 35. The method of Claim 27, wherein said contacting step comprises delivery via one or more methods selected from the group consisting of injection, static soak, liquid flow-through, aerosol spray, condensation or physical placement.

36. The method of Claim 27, further comprising the step of exposing said article to a plasma during the step of exposing the article to negative pressure.

20 37. The method of Claim 36, wherein said method is performed within a first chamber and wherein said plasma is generated in a second, separate chamber and said method further comprises the step of flowing said plasma into said first chamber.

38. The method of Claim 27, wherein said diffusion-restricted environment comprises a container with at least one communication port comprising an exit tube.

25 39. The method of Claim 38, wherein said exit tube is at least 1.0 cm in length.

40. The method of Claim 38, wherein said exit tube has an internal diameter of 9 mm or less.

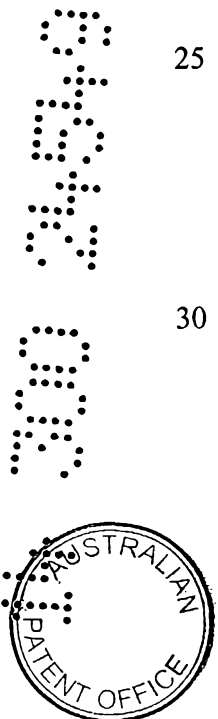
41. The method of Claim 38, wherein said exit tube includes a filter.

42. The method of Claim 40, wherein said filter is sufficient to prevent entry of bacteria from the environment into said container.

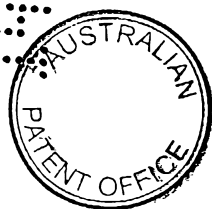
30 43. The method of Claim 27, wherein said source of hydrogen peroxide or peracetic acid is at a concentration of less than 25% by weight.

44. The method of Claim 27, wherein said exposing step is performed for 60 minutes or less.

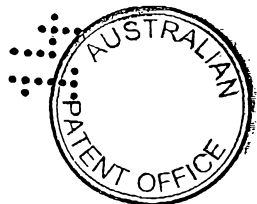
45. The method of Claim 27, further comprising the step of heating said article during said exposing step.



46. The method of Claim 27, wherein the article comprises a lumen.
47. The method of Claim 27, wherein said exposing step comprises exposing said article to negative pressure between 0 and 100 Torr.
48. The method of Claim 27, wherein the contacting step is repeated one or more times.
- 5 49. The method of Claim 27, wherein the exposing step is repeated one or more times.
50. The method of Claim 27, wherein the entire method is repeated one or more times.
51. The method of Claim 27, wherein said diffusion-restricted environment has the same or more diffusion restriction than provided by a single entry/exit port of 9 mm or less in internal diameter and 1 cm or greater in length.
- 10 52. The method of Claim 27, wherein said diffusion-restricted environment is sufficiently diffusion restricted to completely sterilize a stainless steel blade within a 2.2 cm by 60 cm glass tube having a rubber stopper with a 1 mm by 50 cm stainless steel exit tube therein at a vacuum of 10 torr for one hour at 40°C.
53. A method for making a sterilized article within a diffusion-restricted container as  
15 hereinbefore defined, said method comprising:  
    contacting said article with a source of hydrogen peroxide or peracetic acid; and  
    placing said article in said diffusion-restricted container, said container comprising at least one exit tube, said contacting and placing steps being performed in either order; followed by  
    exposing said diffusion-restricted container to negative pressure for a time period sufficient  
20 to effect complete sterilization of said article.
54. The method of Claim 53, wherein the contacting step precedes the placing step and the contacting step is repeated after the placing step.
55. The method of Claim 53, wherein said exit tube has a filter therein.
56. The method of Claim 55, wherein said filter is sufficient to prevent entry of bacteria into  
25 said container.
57. The method of Claim 53, wherein said exit tube is at least 1.0 cm in length.
58. The method of Claim 53, wherein said exit tube has an internal diameter of 9 mm or less.
59. The method of Claim 53, wherein the exposing step is repeated one or more times.
60. The method of Claim 53, wherein the entire method is repeated one or more times.
- 30 61. The method of Claim 53, wherein said contacting step comprises delivery via one or more methods selected from the group consisting of injection, static soak, liquid flow-through, aerosol spray, condensation or physical placement.
62. The method of Claim 53, further comprising the step of exposing said container to a plasma during the step of exposing the container to negative pressure.



63. The method of Claim 62, wherein said method is performed within a sealed chamber and said plasma is generated within said chamber.
64. The method of Claim 53, wherein said exposing step is performed for 60 minutes or less.
65. The method of Claim 53, further comprising the step of heating said container during said exposing step.
66. The method of Claim 53, further comprising heating said source of hydrogen peroxide or peracetic acid prior to said contacting step.
67. The method of Claim 53, wherein said exposing step comprises exposing said container to negative pressure between 0 and 100 Torr.
68. The sterilized article within a diffusion-restricted container produced by the method of Claim 53.
69. The sterilized article within a diffusion-restricted container produced by the method of Claim 56.
70. The method of Claim 53, wherein said source of hydrogen peroxide or peracetic acid comprises a liquid or condensed vapor.
71. A method for making a sterilized article within a diffusion-restricted container as hereinbefore defined, said method comprising:  
 placing said article in said diffusion-restricted container, said container comprising at least one communication port comprising an exit tube or air and vapor permeable window; and  
 contacting said diffusion-restricted container with a source of hydrogen peroxide or peracetic acid, said placing and contacting steps being performed in either order;  
 followed by exposing said diffusion-restricted container to negative pressure for a time period sufficient to effect complete sterilization of said article.
72. The method of Claim 71, wherein said exit tube has a filter therein.
73. The method of Claim 72, wherein said filter is sufficient to prevent entry of bacteria into said container.
74. The method of Claim 71, wherein said exit tube is at least 1.0 cm in length.
75. The method of Claim 71, wherein said exit tube has an internal diameter of 9 mm or less.
76. The method of Claim 71, wherein said communication port is connected through a connector to said article, so that sterilant vapor may flow through said article and out of said container.
77. The method of Claim 76, wherein said connector comprises tubing or an adaptor which can be attached to a lumen of said article, or an enclosure which contains a portion of said article with said lumen.



78. The method of Claim 71, wherein said exit tube is additionally connected to a valve outside said container, said valve in connection with a vacuum source.
79. The method of Claim 71, wherein said window is impermeable to microorganisms.
80. The method of Claim 71, wherein the exposing step is repeated one or more times.
- 5 81. The method of Claim 71, wherein the entire method is repeated one or more times.
82. The method of Claim 72, wherein said contacting step comprises delivery via one or more methods selected from the group consisting of injection, static soak, liquid flow-through, aerosol spray, condensation or physical placement.
83. The method of Claim 71, further comprising the step of exposing said container to a plasma  
10 during the step of exposing the container to negative pressure.
84. The method of Claim 83, wherein said method is performed within a sealed chamber and said plasma is generated within said chamber.
85. The method of Claim 71, wherein said exposing step is performed for 60 minutes or less.
86. The method of Claim 71, further comprising the step of heating said container during said  
15 exposing step.
87. The method of Claim 71, further comprising heating said source of hydrogen peroxide or peracetic acid prior to said contacting step.
88. The method of Claim 71, wherein said exposing step comprises exposing said container to negative pressure between 0 and 100 Torr.
- 20 89. The sterilized article within a diffusion-restricted container produced by the method of Claim 71.
90. The sterilized article within a diffusion-restricted container produced by the method of Claim 73.
91. The method of Claim 71, wherein said source of hydrogen peroxide or peracetic acid  
25 comprises a liquid, a solid or condensed vapor.
92. The method of Claim 91, wherein said solid comprises a urea peroxide complex or sodium pyrophosphate peroxide complex or like complex.

DATED: 14 March 2000

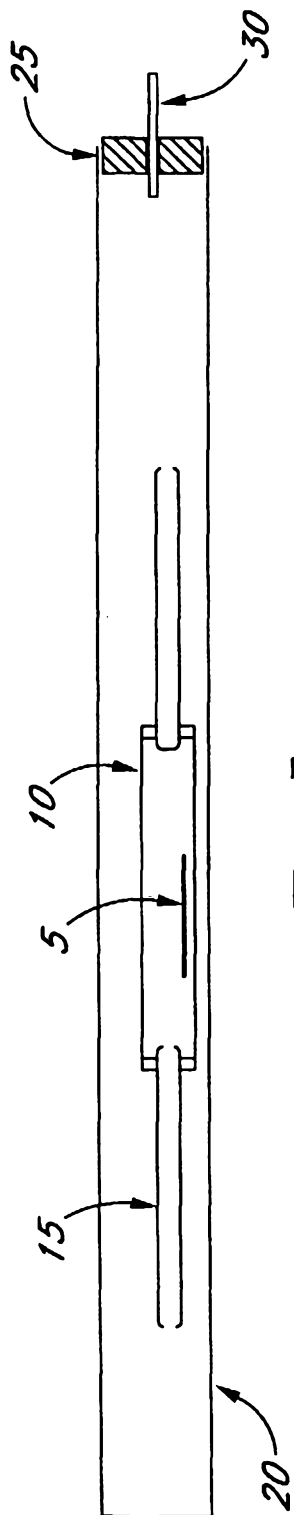
**CARTER SMITH & BEADLE**  
Patent Attorneys for the Applicant:

ETHICON, INC

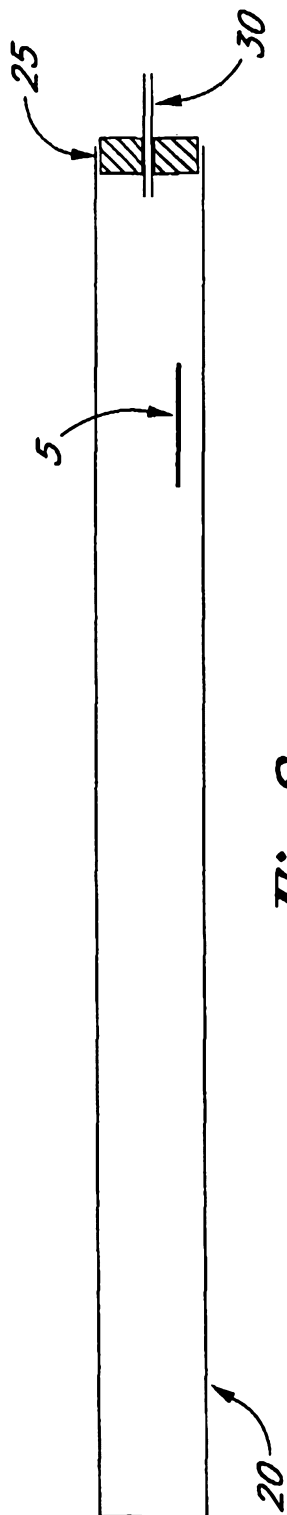
35



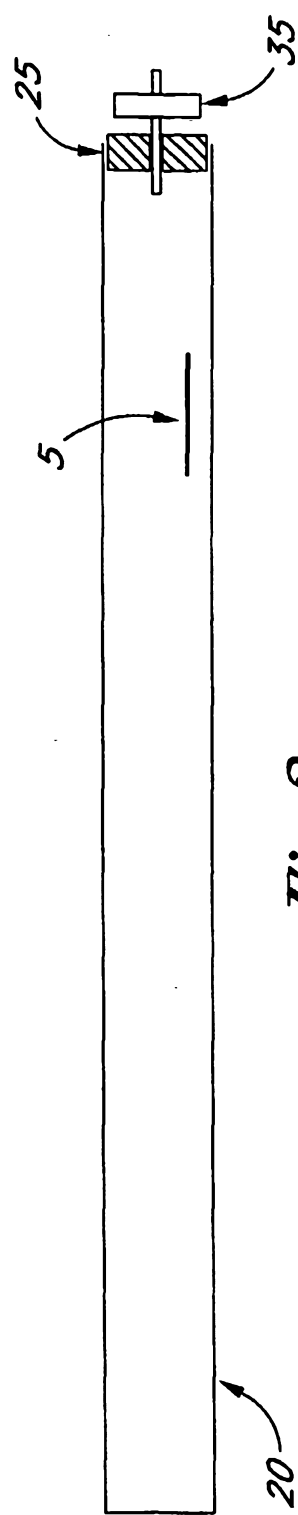




*Fig. 1*

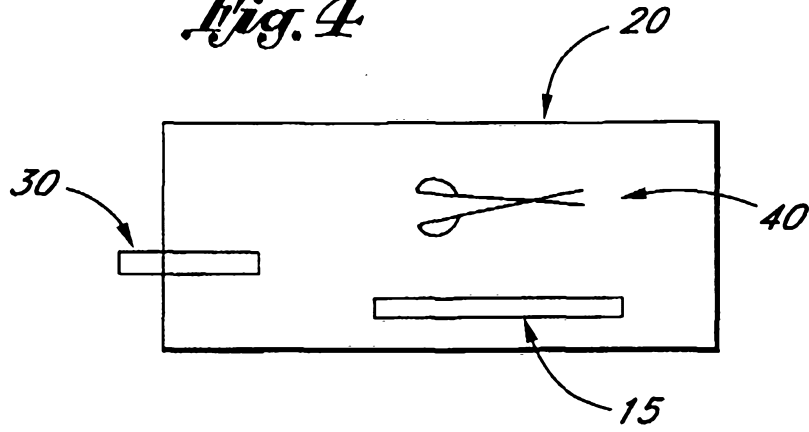


*Fig. 2*

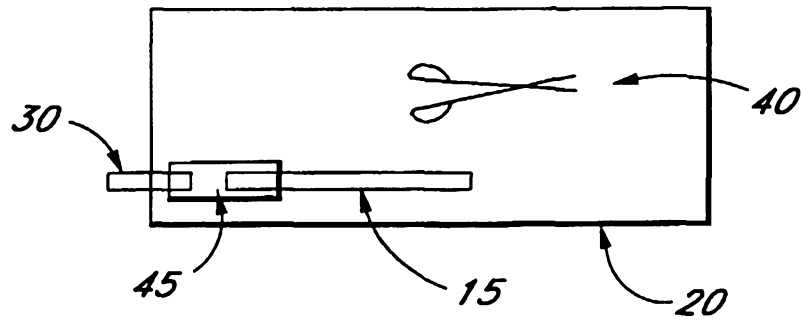


*Fig. 3*

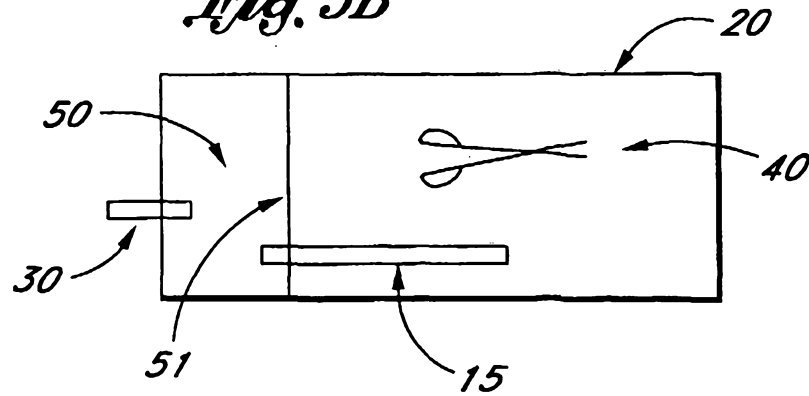
*Fig. 4*



*Fig. 5A*



*Fig. 5B*



*Fig. 6*

