

[72] Inventors **Earle B. McDowell;**
Clifford M. Jones, Waynesboro, Va.
 [21] Appl. No. **829,574**
 [22] Filed **June 2, 1969**
 [45] Patented **Apr. 13, 1971**
 [73] Assignee **General Electric Company**

3,343,036 9/1967 Steen..... 317/31
 3,407,338 10/1968 Secunde..... 317/31
 3,416,442 12/1968 Brown et al..... 101/93
 3,512,044 5/1970 Jones..... 317/31X

Primary Examiner—William B. Penn
Attorneys—Joseph B. Forman, Michael Masnik, Frank L. Neuhauser and Oscar B. Waddell

[54] **UNDERSPEED AND UNDERVOLTAGE PROTECTION FOR PRINTER**
 18 Claims, 4 Drawing Figs.

[52] U.S. Cl. **101/93,**
 317/31, 317/9, 307/130, 307/149
 [51] Int. Cl. **B41j 9/38,**
 H02h 3/28
 [50] Field of Search..... 101/93, 93
 (C), 96, 95, 111, 1, 426; 307/120, 130, 149, 9;
 317/31, 9, 36; 340/267, (Inquired), 210

[56] **References Cited**
UNITED STATES PATENTS
 2,071,984 2/1937 Minneci 307/130X
 2,140,390 12/1938 Lunge 307/120X
 2,936,704 5/1960 Hense 101/93
 3,012,499 12/1961 Amada 101/93
 3,216,348 11/1965 Oldenburg et al. 101/93
 3,313,984 4/1967 Hupp..... 317/33

ABSTRACT: An underspeed and undervoltage protection system for an electromechanical printer. The printer includes a plurality of moving characters actuated by stationary print hammers. The speed of the moving characters is continuously monitored along with the input voltage to the printer system. A synchronizing signal is provided which indicates when the characters are positioned to permit application of buss voltage which is the source of energization of the print hammers. When the speed of the characters and the input voltage reach predetermined minimum values, power is applied to a power buss for energizing the print hammers, the application of power being delayed until the synchronizing signal indicates that the print hammers are not in position to be energized. Similarly, if the speed of the characters or the input voltage subsequently falls below the predetermined minimum values, the hammer power buss is synchronously deenergized so as to prevent damage to the printer mechanism.

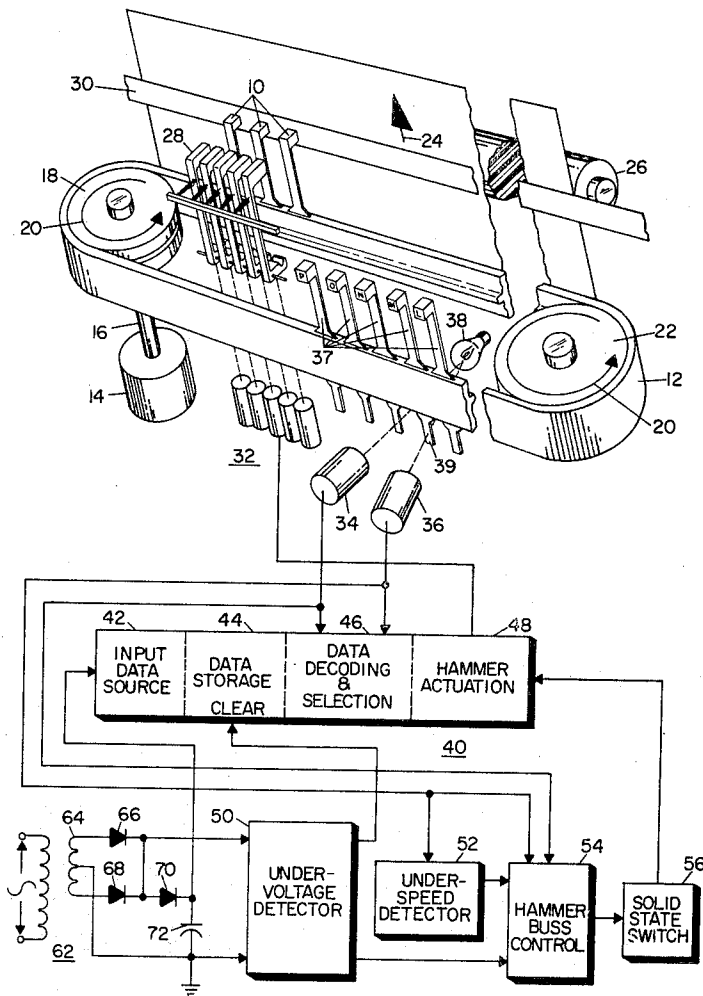

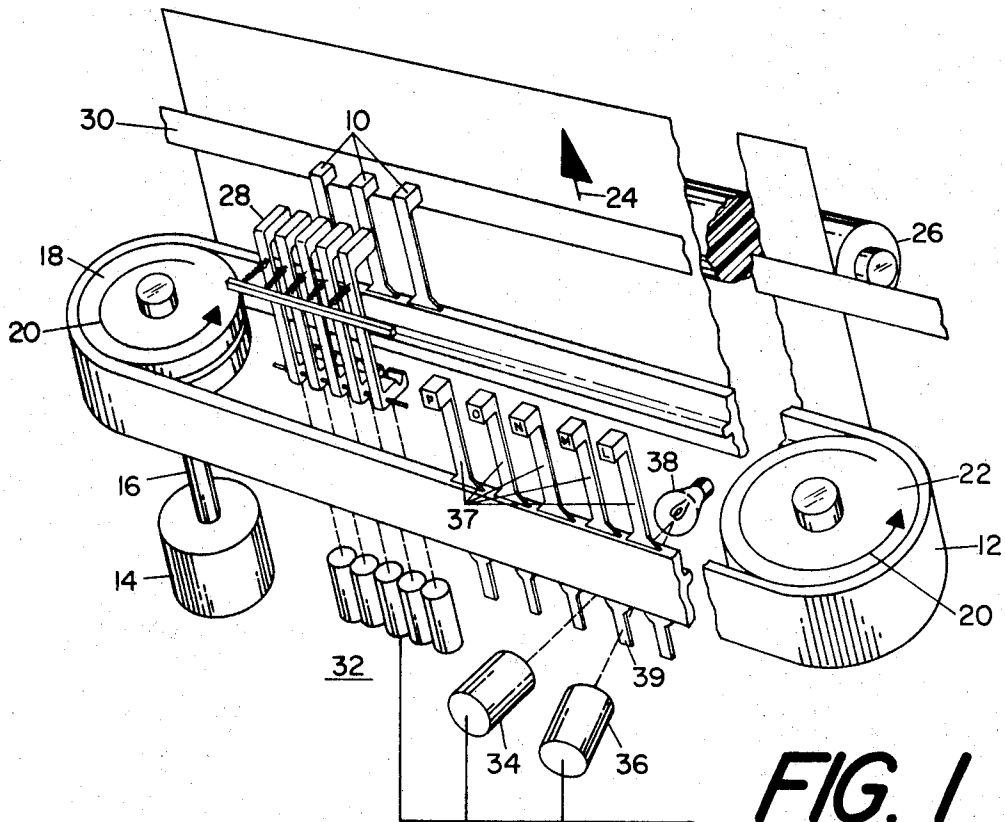
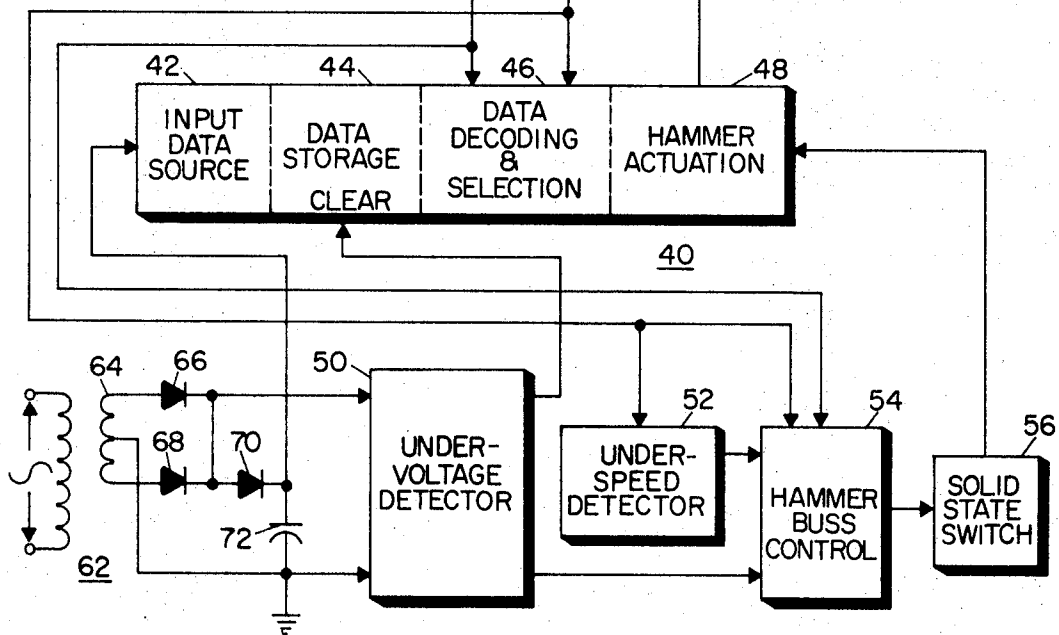

FIG. 1



INVENTOR.
EARLE B. McDOWELL
CLIFFORD M. JONES
BY *Michael Masnik*
THEIR ATTORNEY

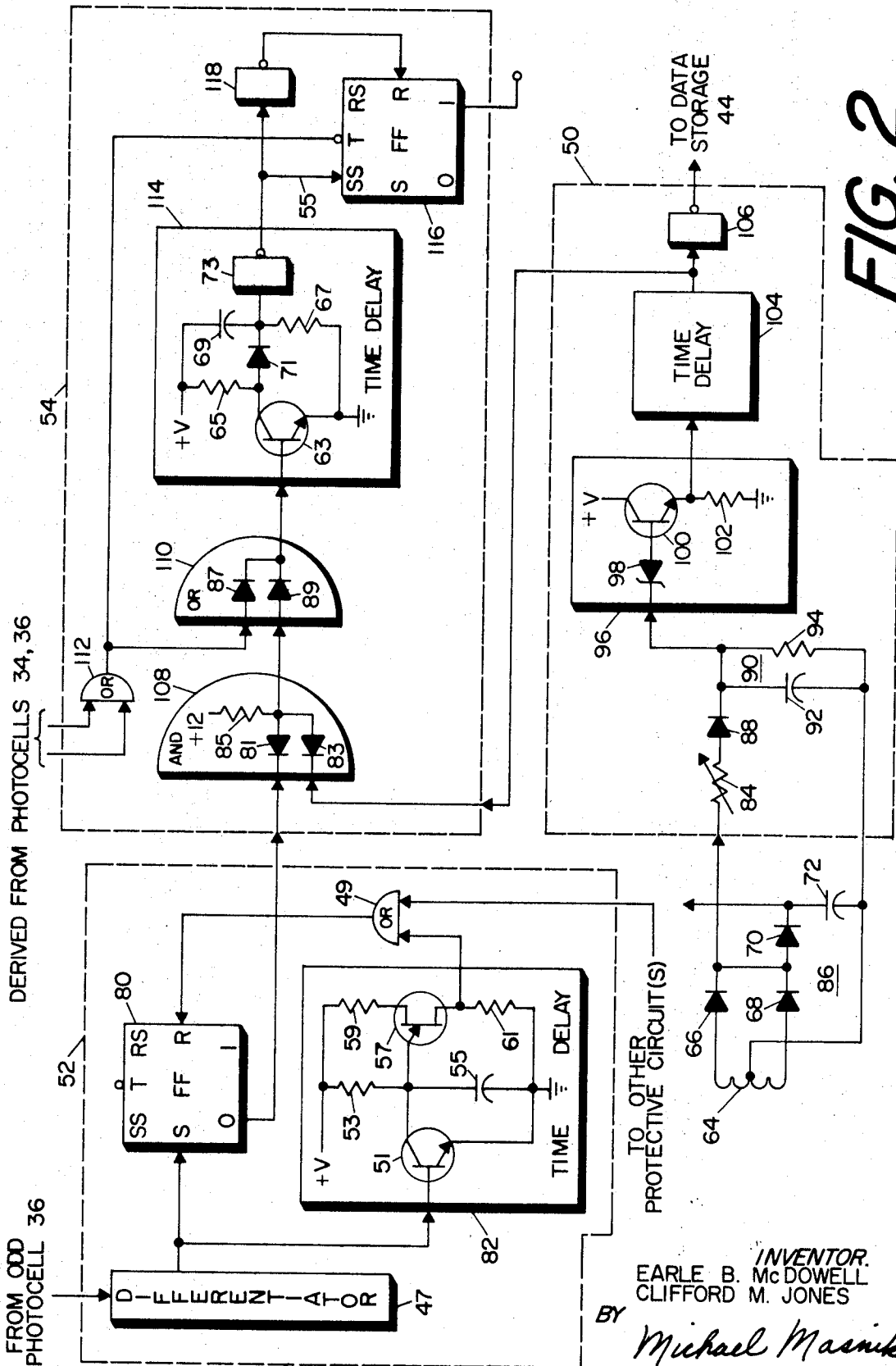

FIG. 2

INVENTOR.
EARLE B. McDOWELL
CLIFFORD M. JONES
BY *Michael Masnik*
THEIR ATTORNEY

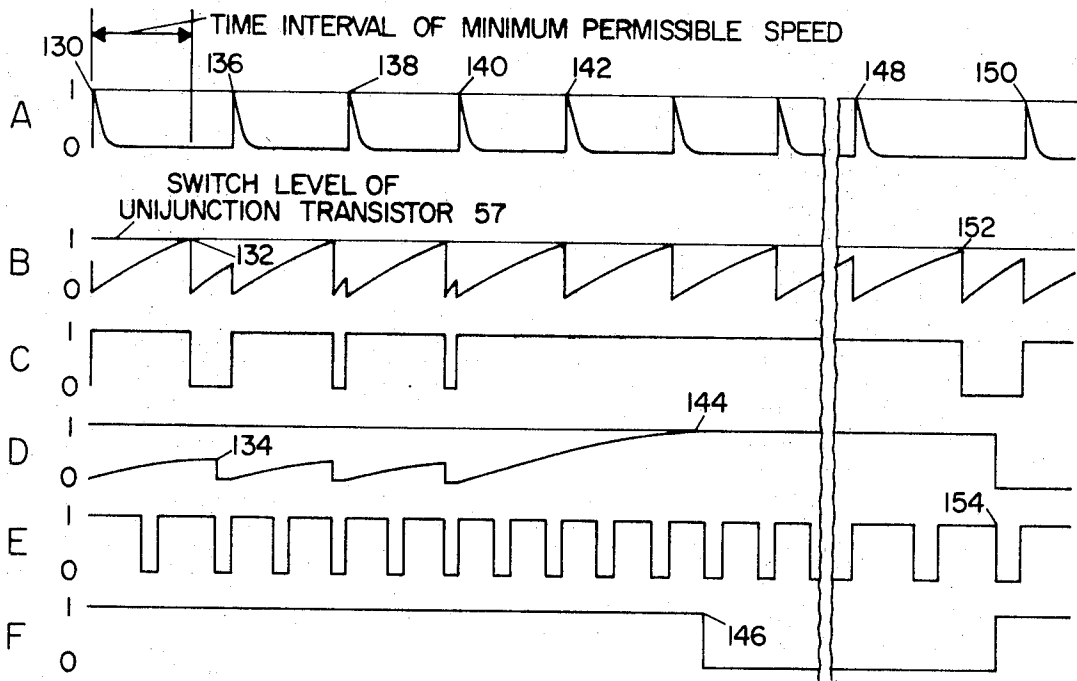

FIG. 3

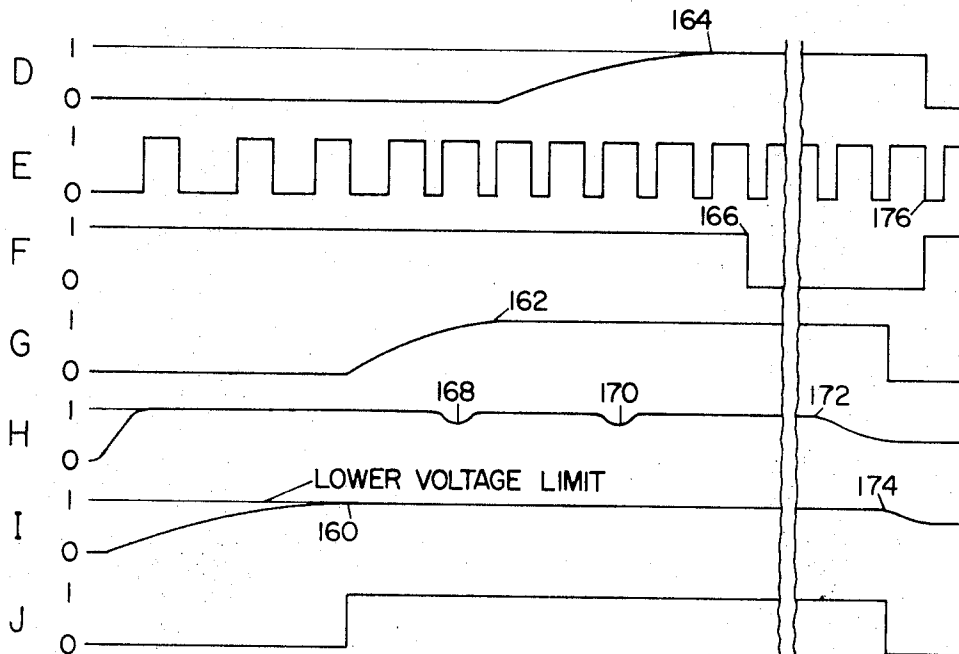

FIG. 4

INVENTOR
EARLE B. McDOWELL
CLIFFORD M. JONES
BY *Michael Masonik*
THEIR ATTORNEY

1

UNDERSPEED AND UNDERVOLTAGE PROTECTION FOR PRINTER

BACKGROUND OF THE INVENTION

The present invention relates to protection systems for printers. More specifically, the invention relates to an underspeed and/or an undervoltage protection system for a printer having a plurality of movable characters which are caused to effect printing, as for example, by electrically energizable print hammers.

A broad variety of protection systems for all types of electrical and mechanical equipment are known. Among the many examples are systems which provide for protection by sensing underspeed, overspeed, undervoltage, overvoltage, etc. The particular needs of individual types of protective schemes depends, in large part, upon the particular characteristics of the apparatus to be protected.

The present invention is particularly slanted toward, and suited for, protection of electromechanical printers by sensing underspeed and undervoltage conditions. The need for such protection is particularly acute in printers which have a number of moving characters which are selectively engaged by stationary print hammers. Printers of this type include, for example, chain printers and belt printers wherein the print characters are carried on continuously moving chains or belts. The moving print characters are engaged by stationary print hammers which are electrically energized by a control system so as to strike the appropriate character.

The control system controls the energization of the print hammers by sensing the position of the characters in the chain or belt. However, since the characters are moving, it is necessary to energize the print hammers before the characters are directly in front of the print hammer so as to "lead" the moving character. The amount of "lead" required depends, of course, upon the speed of the moving character and the amount of time required for the print hammer to travel to the printing position. It will be apparent that too much "lead" or too little "lead" will result in the print hammer missing the character and may further result in jamming of, and damage to, the printer mechanism.

For these reasons, the speed of the moving characters and the amount of voltage applied to energize the print hammers become extremely important factors in such a control system. If either of these characteristics fall below predetermined limits, there is a significant likelihood that the hammers or the print characters will be damaged.

Not only must a control system for a printer of this type ensure that the character speeds and hammer voltage are proper but it must also prevent premature energization or deenergization of the print hammers. Thus, in certain situations it may be necessary to delay the energization or deenergization of the power buss which feeds the print hammers until such energization or deenergization can be done without damage to the printer mechanism.

SUMMARY OF THE INVENTION

It is an object of the invention to provide an improved protective circuit for a printer.

It is an object of the present invention to provide a novel protection system for preventing damage to an electromechanical printer.

It is a further object to provide such a protection system which protects the printer from damage in case of underspeed or undervoltage conditions.

It is a still further object of the present invention to provide such underspeed and undervoltage protection which is synchronized so as to prevent improper energization or deenergization of the printer.

Briefly stated, these and other objects are carried out by comparing the speed of the moving print characters and the input voltage to the printer with predetermined minimum reference values. A synchronizing signal is provided so as to indicate when the print characters are positioned so as to be

2

permitted to be engaged by electrically energizable print hammers. The protection system is synchronized with this synchronizing signal so as to assure that the printer is energized or deenergized only when the synchronizing signal indicates that the print characters are not in position to be engaged by the print hammers.

BRIEF DESCRIPTION OF THE DRAWINGS

While the specification concludes with claims particularly pointing out and distinctly claiming the subject matter which is regarded as the invention, an illustration of a particular embodiment can be seen by referring to the specification in connection with the accompanying drawings in which:

FIG. 1 is a perspective view of an electromechanical printer and a block diagram of a control system for the printer,

FIG. 2 is a detailed electrical diagram of a protection system comprising a preferred embodiment of the present invention;

FIG. 3 is a series of waveforms illustrating the operation of the underspeed detector of FIGS. 1 and 2; and

FIG. 4 is a series of waveforms illustrating the operation of the undervoltage detector of FIGS. 1 and 2.

DESCRIPTION OF THE PREFERRED EMBODIMENT

FIG. 1 is a perspective view of a printer and a block diagram of a control system for the printer. The present invention is particularly suited for use in a printer which has a plurality of characters which are continuously movable as shown in perspective view of the printer of FIG. 1. A printer of the type referred to may comprise, for example, a belt printer as illustrated in FIG. 1.

The print characters 10 are carried on a continuously movable belt 12 which is driven at a predetermined speed by a drive motor shown generally at 14. The drive motor 14 is coupled by way of a shaft 16 to a power pulley 18 which drives the belt in a counterclockwise direction as indicated by the arrows 20. The belt 12 bearing the print characters 10 is continuously driven by the power pulley 18 and a second pulley 22. A recording medium such as a piece of paper 24 is provided and supported against a platen or roller 26. A plurality of hammers 28 are positioned so as to selectively strike the print characters 10 and urge them against an ink ribbon 30 which passes between the print characters and the recording medium 24.

The position of the characters on the rotating belt 12 is sensed by a pair of photocells 34, 36 which are activated by a light source 38. The print characters 10 are supported by flexible arms 37 which have fingers 39 protruding below the belt 12. The fingers 39 pass between the light source 38 and the photocells 34, 36 so as to indicate the position and speed of the characters on the belt 12.

The hammers 28, the photocells 34, 36, and the fingers 39 are positioned so that the output of the photocells 34, 36 indicate when the hammers 28 can be actuated. Note that the printer of FIG. 1 has one hammer for each column to be printed, but that the print characters 10 are separated by the width of a column. The hammers 28 are separated into two groups, even and odd, according to the particular column with which they are associated. Since the photocells 34, 36 are similarly spaced, the output of photocell 34 is used to indicate when the "even" hammers can be actuated whereas the output of photocell 36 is used to indicate when the "odd" hammers can be actuated.

The printer of FIG. 1 is controlled by a control system shown generally at 40. The control system 40 includes a first section 42 which is the source of the input data to be printed by the printer. Input data source 42 may comprise, for example, a keyboard for directly activating the printer or, alternatively, may comprise part of a data receiver which receives data from a remote location to be printed at the printer location. The data from the input data source 42 is fed to a data storage unit 44 which stores the input data until it is printed. The contents of data storage 44 are examined by a

data decoding and selection circuit 46 which has the output of the photocells 34, 36 as its inputs. The function of the data decoding and selection portion of the control system 40 is to determine the position of the characters (on the belt) so as to determine when to actuate the hammers to print the characters stored. The output of the data decoding and selection circuit 46 is fed to a hammer actuation circuit 48 which applies power to the appropriate solenoid 32 so as to activate the hammer and print the desired character. A system for controlling a printer of this type may be found, for example, in copending application, Ser. No. 734,501; filed Jun. 4, 1968 (Docket 45-SL-01033), assigned to the assignee of the present invention. In this application the circuit 46 applies a preconditioning signal to the hammer drive mechanism to indicate which hammers are to be actuated to print during the next print cycle. One or more hammers may be actuated at a time.

Since the print hammers 28 are stationary and the characters 10 are moving, one of the primary purposes of the control system 40 is to synchronize the recurrent electrical energization of the print hammers with the rotation of the print characters on the belt 12. It is not only necessary to select the appropriate print hammer but also is important to assure that the print hammers are energized at the appropriate time. Improper energization of the print hammers 28 can result in damage to both the hammers themselves and also to the print characters 10. That is, if one of the print hammers 28 is energized improperly, it may miss the character completely and instead fall into one of the spaces between the characters 10. Since the characters are moving, the next character may catch the side of the print hammer and the result may be a bent character or print hammer.

In order to ensure that the print hammers are properly energized, the system must, as pointed out in the above cited copending application, be appropriately synchronized with the rotation of the character belt 12. In addition, even if the hammers are appropriately synchronized, damage may still result if the voltage applied to the printer and/or the hammer solenoids is too low or if the speed of the belt 12 is below a predetermined limit.

As to undervoltage conditions, it will be apparent that the effect of applying a decreased voltage to the hammer solenoids is to reduce the amount of actuating force applied to the hammers 28 when the solenoids 32 are activated. Thus, if the hammer is energized by a voltage below predetermined limits, it will not travel as fast as is necessary in order to strike the desired character but instead may miss the print character altogether, resulting in damage to the printer mechanism. In addition, it is also necessary to assure that when power is first applied to the system the hammers are not prematurely energized.

If the belt speed is below normal, it can be appreciated that the energization of one of the hammers may also result in damage to the printer mechanism. Since the hammers are stationary and the characters are moving, the hammers must be energized before the desired character is directly in front of the hammer. That is, the hammer must be energized so as to "lead" the desired character. Thus, if the characters are traveling at a rate below a predetermined limit, the hammer will arrive at the character position before the print character itself is there resulting in damage to either the print characters or the hammers themselves.

In order to avoid these sources of difficulty, an undervoltage detector 50, and underspeed detector 52 are provided to monitor the system voltage and belt speed. The undervoltage detector 50 and the underspeed detector 52 control the application of power to the hammer buss by way of a hammer buss control circuit 54. The hammer buss control circuit 54 operates to ensure that power is not applied to the hammer buss prematurely and that it is removed from the hammer buss in a synchronous fashion when either the speed or voltage falls below predetermined limits. As illustrated in FIG. 1, fast switching means, such as a solid-state switch 56 is provided to

control the application of power to the hammer buss. Activation of switch 56 is controlled by the presence of a signal on hammer buss control 54.

More specifically, the undervoltage detector 50 monitors the input voltage supplied to an input transformer 62 including a secondary winding 64 which feeds through a full wave rectifier including diodes 66, 68 and 70 whose output is supplied to the control system for the main source of control power. A filter capacitor 72 is also provided so as to reduce variations in the DC voltage supplied to the control system 40.

When an undervoltage condition is detected, the output of undervoltage detector 50 is relayed to the hammer buss control 54 to deenergize solid-state switch 56 in synchronism with the character belt fingers. At the same time, a second output from undervoltage detector 50 is also relayed to the data storage portion 44 of the control system 40 so as to clear data stored in the control system at that time.

The underspeed detector 52 monitors the output of one photocell 36 (which represents the speed of the character belt) and indicates when the belt speed is below a predetermined minimum. The output of the underspeed detector 52 is also fed to the hammer buss control 54 and operates to deenergize the hammer buss when the speed falls below predetermined limits, again in synchronism with the position of the character belt fingers.

THE LOGIC ELEMENTS

FIG. 2 is a detailed logic diagram of a preferred embodiment of the undervoltage detector 50, the underspeed detector 52, and the hammer buss control 54 of FIG. 1. Before describing in detail the operation of the logic diagram of FIG. 2, it will be necessary to briefly describe the operation of certain logic elements contained therein.

The present embodiment will be explained with respect to a digital logic system wherein the signals are encoded in two voltage levels. These voltage levels will be referred to, for the sake of convenience, as logic 1 and logic 0. Logic 1 may be, for example, a positive voltage such as +12 volts and the logic 0 level may be lower voltage such as 0 volts. While the preferred embodiments shown will be described using this notation, the present invention is not to be limited to the particular logic levels described since it will be apparent to those skilled in the art that any type of logic system, either positive or negative, could carry out the principles underlining this invention with equal facility.

The logic element 80 labeled FF is a bistable device commonly referred to and herein defined as a J-K flip-flop. It has three input terminals SS, RS, and T. The SS input terminal is the set steering input terminal, the RS input terminal is the reset (or clear) steering terminal, and the T input terminal is the trigger terminal. Operation, briefly, is as follows—the presence of a logic 1 at the set steering terminal SS followed by a trigger pulse (a signal which goes from logic 1 to logic 0) on the trigger terminal T sets the flip-flop 80. Conversely, the presence of a logic 1 on the reset steering terminal RS followed by a trigger at the trigger terminal T results in resetting (or clearing) the flip-flop 80.

In addition to the three inputs referred to above, the J-K flip-flop has direct set and reset input terminals labeled S and R respectively. The presence of a logic 1 at the direct set terminal S immediately sets the flip-flop 80. Conversely, the presence of a logic 1 at the direct reset input terminal R immediately resets the flip-flop 80.

To indicate its present state, a J-K flip-flop has two output terminals labeled 0 and 1. These terminals are labeled to indicate the logic signal present at the terminal when the flip-flop is in its normal or reset state. That is, the 0 terminal has a logic 0 present at the terminal and the 1 output terminal has a logic 1 present at that terminal when the flip-flop is in the reset state. When the flip-flop 80 assumes the set state, the logic signals present at the two output terminals are reversed so that a logic 1 is present at the 0 output terminal and vice versa when the flip-flop 80 is in the set state.

The logic element 82 in FIG. 2 is a time delay unit. It has a predetermined time delay which begins when its input (indicated by the arrow) goes to logic 0. At the end of the predetermined time delay, the output momentarily switches from logic 0 to logic 1. If the input, however, goes to logic 1 before the predetermined time delay passes, the time delay cycle is terminated and restarted when the input returns to the logic 0 level.

The time delay unit 82 includes an NPN transistor 51 having its base connected to the input. The collector of transistor 51 is connected to the junction of a first resistor 53 and a capacitor 55. When the base of transistor 51 is at logic 1 level, transistor 51 is turned full on so as to short out capacitor 55. As long as transistor 51 is turned on by the presence of logic 1 at the input, capacitor 55 cannot charge through resistor 53. However, when the input to time delay 82 goes to logic 0, transistor 51 is turned off so that capacitor 55 charges through resistor 53 at a rate determined by the RC time constant of these elements.

The junction of resistor 53 and capacitor 55 is also connected to the emitter of a unijunction transistor 57. A pair of resistors 59, 61 are connected to the bases of unijunction transistor 57 so as to provide temperature compensation and means for obtaining an output voltage.

The RC network consisting of resistor 53 and capacitor 55 cooperates with unijunction transistor 57 and its associated resistors 59, 61 to form a conventional unijunction relaxation oscillator. Capacitor 55 charges at a predetermined rate until the voltage on the emitter of the unijunction transistor 57 exceeds a predetermined percentage of the base-to-base voltage at which point unijunction transistor 57 conducts momentarily thereby discharging capacitor 55. Prior to the time the unijunction transistor 57 conducts, the output of the time delay 82 is at effectively zero volts or logic 0. However, when unijunction transistor 57 conducts, the output raises to the positive voltage representing logic 1. However, since the transistor 51 is connected in parallel with capacitor 55, capacitor 55 is discharged when transistor 51 conducts. Therefore, the time delay 82 will never change its output to logic 1 if transistor 51 is energized before the voltage on capacitor 55 exceeds the predetermined percentage of the base-to-base voltage of unijunction transistor 57.

The logic elements 104, 114 are time delay units which are somewhat different than time delay 82. The operation of time delay 114 will be explained in detail with the understanding that time delay 104 is substantially similar in construction and operation. Briefly, time delay 114 operates such that a logic 1 at its input is delayed and, after a predetermined time delay, the output goes to logic 1. On the other hand, if the input to time delay 114 is a logic 0, the output assumes a logic 0 with substantially smaller delay.

The input to time delay 114 is fed to the base of an NPN transistor 63. A first resistor 65 is connected from a positive voltage, +V, to the collector of transistor 63 and the emitter of transistor 63 is connected to 0 volts. An RC network consisting of resistor 67 and capacitor 69 is connected from the positive voltage +V to 0 volts with the junction of resistor 67 and capacitor 69 which is connected to an inverter 73 serving as the output of time delay 114. Finally, a diode 71 is connected from the emitter of transistor 63 to the junction of resistor 67 and capacitor 69.

When the input to time delay 114 is a logic 1, the timing cycle begins. The presence of the logic 1 at the base of transistor 63 turns transistor 63 on. When transistor 63 is turned on, its collector is at 0 volts so that diode 71 cannot conduct. Under these circumstances, the RC network consisting of resistor 67 and capacitor 69 begins to initiate the timing cycle since capacitor 69 begins to charge through resistor 67. After the time delay established by the RC time constant of these components, the output of time delay 114 will eventually reach the logic 1 level.

On the other hand, when the input to time delay 114 is a logic 0, the presence of logic 0 at the base of transistor 63 turns transistor 63 off. When transistor 63 is turned off, the

collector rises to essentially the positive voltage, +V. This causes diode 71 to become conductive so as to almost immediately discharge capacitor 69. Thus, the presence of a logic 0 at the input to time delay 114 causes its output to switch, after a very short time delay, to the logic 0 level.

The logic element 108 in FIG. 2 is an AND gate. AND gate 108 operates such that its output will be a logic 1 wherever both of its inputs (indicated by the arrows) are logic 1. Under all other conditions the output of AND gate 108 will be a logic 0. The AND gate 108 in FIG. 2 includes a pair of diodes 81, 83 and a resistor 85 which is connected to a positive voltage representative of the logic 1 level. If either of the inputs are logic 0 (0 volts) the diode associated with that input conducts thereby pulling the output of the AND gate down to logic 0. If, however, both inputs are logic 1 then neither of the diodes 81, 83 will conduct so that the output of AND gate 108 assumes the positive voltage equivalent to a logic 1.

The logic element 110 of FIG. 2 is a nonexclusive OR gate. OR gate 110 operates such that its output will be a logic 1 if either (or both) of its inputs (indicated by the arrows) are logic 1. The OR gate 110 of FIG. 2 consists of a pair of diodes 87, 89 which are poled so as to conduct in the positive direction. Therefore, if either of the inputs is a logic 1 (+12 volts) then the output will assume that voltage since the diode associated with that particular input will conduct in the appropriate direction.

Finally, the logic element 106 and element 118 in FIG. 2 are inverters. Inverters 106 and 118 operate such that the signal on their outputs (indicated by the circle) will be the inverse of the signal at their inputs (indicated by the arrow). Thus, if their input is a logic 1, the output of inverter 106 or 118 will be a logic 0 and vice versa.

DESCRIPTION OF FIGURE 2

The underspeed detector of FIG. 1 includes a flip-flop 80 and a time delay 82. The output pulses from the photocell 36 in FIG. 1 are fed through a differentiator 47 to the direct set terminal S of flip-flop 80 so that flip-flop 58 sets each time these input pulses go to logic 1. These same pulses are also fed to the input to time delay 82. As explained above, the presence of a logic transition of 1 to 0 at the input of the time delay 82 begins the timing cycle.

The output of time delay 82 forms one input to an OR gate 49. The other input(s) to OR gate 49 come from other protective circuits which require the synchronous deenergization of the hammer buss. The output of OR gate 49 is connected to the direct reset input R of flip-flop 80 so as to reset flip-flop 80 to indicate that the hammer buss is to be deenergized. Briefly, as will be seen hereinafter, the minimum belt speed is set by time delay 82 and if the speed of the belt is above the minimum permissible speed, flip-flop 80 will stay set. On the other hand, if the speed of the belt is below the minimum permissible speed, time delay 82 will reset flip-flop 80 before the next input pulse arrives on the set input terminal S.

The undervoltage detector of FIG. 1 monitors a portion of the input voltage to determine whether it is above a predetermined minimum. The circuit includes a variable resistor 84 which is connected to the DC output of the power supply shown generally at 86. A diode 88 is connected in series with variable resistor 84 and feeds a time delay circuit shown generally at 90 including a capacitor 92 and a resistor 94. Briefly, time delay circuit 90 provides a time delay so as to prevent an undervoltage indication under temporary conditions of line droop, etc. As was explained in FIG. 1, the main DC power supply includes a number of filter capacitors such as capacitor 72 which can maintain the DC output fed to the printer system long enough to overcome minor variations in the input voltage.

The input voltage is monitored by a comparator circuit 96 which compares the input voltage with a predetermined reference established by a Zener diode 98. If the input voltage

is greater than the reference voltage established by the breakdown voltage of Zener diode 98, Zener diode 98 will conduct. Conduction of Zener diode 98 causes transistor 100 to turn on so that the output of the comparator circuit 96 will be a logic 1. Therefore, the output of the comparator circuit 96 will be a logic 1 if the input voltage is above the predetermined reference. On the other hand, if the input voltage is below the breakdown voltage of the zener diode 98, it will not conduct. This causes transistor 100 to turn off, switching the output of the comparator circuit 96 to logic 0 by virtue of pull-down resistor 102 connected to 0 volts.

The output of the comparator circuit 96 is fed to a time delay circuit 104 which is identical to time delay circuit 114 explained above. The purpose of time delay 104 is to allow the power supply to stabilize before applying power to the hammer buss and logic. After the preset time, the output of time delay 104 goes to logic 1 indicating that the input voltage is above the predetermined minimum and has stabilized so as to allow synchronous energization of the hammer buss.

As was pointed out in the description of FIG. 1, an undervoltage condition may result in the storage of erroneous data in the data storage portion 44 of the control system. For this reason, the undervoltage detector 50 assures that no data is stored during undervoltage conditions and further acts to clear all data previously stored if the input voltage drops below the predetermined reference. This is accomplished by an inverter 106 whose input is connected to the output of time delay 104. The output of inverter 106 is connected to the data storage portion 44 of the control system. If the input voltage is below the predetermined reference, the output of time delay 104 is a logic 0. This results in a logic 1 at the output of the inverter 106.

The presence of a logic 1 on the CLEAR input to data storage 44 clears all stored data and prevents any additional data from being entered. It is important to note that clearing the data storage portion 44 of the control system 40 has the effect of providing alternative protection for the hammers and print characters since this prevents any further energization of the hammers. In some applications, it may not be necessary to remove the power from the hammer buss in case of an undervoltage since clearing the stored data may have the same effect as the synchronous energization and deenergization of the hammer buss.

The hammer buss control 54 of FIG. 1 includes a first AND gate 108 which has as its inputs the outputs of the undervoltage and underspeed detectors 50, 52. If the belt speed and input voltage are both correct, the output of AND gate 108 will be a logic 1 since both of its inputs are logic 1. The output of AND gate 108 forms one of the inputs to OR gate 110. The other input to OR gate 110 comes from an OR gate 112 which ORS the outputs derived from the photocells 34, 36 and acts as a synchronizing signal.

The output of OR gate 110 forms the input to a time delay 114. Time delay 114 assures that both the voltage and the belt speed have stabilized before permitting the hammer power buss to be energized. After the delay of time delay 114 has passed, flip-flop 116 will be steered to assume the set state since the output of time delay 114 is connected to the set steering input 55. The trigger input T of flip-flop 116 is connected to the output of OR gate 112. By using this source as the trigger for flip-flop 116, the system ensures that the hammer buss is not energized except during those periods when the hammers are not permitted to be activated.

If either the voltage or speed should fall below predetermined minimums, flip-flop 116 will synchronously reset since the output of time delay 114 is fed through an inverter 118 to the direct reset terminal R of flip-flop 116. Resetting flip-flop 116 removes power from the hammer power buss by deenergizing the switch in FIG. 1.

THE WAVEFORMS OF FIGURES 3-4

FIG. 3 is a series of waveforms illustrating the operation of the underspeed detection portion of the preferred embodiment of FIG. 2. The waveforms shown are lettered A through F to correspond to the locations in FIG. 2 similarly indicated.

The waveform labeled A is the output of the differentiator 47 in FIG. 2. As was pointed out, the differentiator 47 differentiates the positive-going portions of the output of the odd photocell 36 of FIG. 1, and the interval between signals is therefore, an indication of the speed of the character belt 12. This signal forms the input to the underspeed detector 52.

The initial portion of the waveforms of FIG. 3 assumes that speed of the character belt 12 has not yet reached minimum permissible speed so as to allow the application of power to the hammer buss. Pulse 130 in waveform A initiates the timing cycle of the speed detector 52 by setting flip-flop 80 (as indicated in waveform C) and by starting the time delay 82 by discharging capacitor 55 through transistor 51 (as indicated by waveform B). Capacitor 55 in the time delay 82 charges at the exponential rate shown until the voltage on capacitor 55 is sufficient to cause unijunction transistor 57 to conduct as is shown at 132 in waveform B. At this point, unijunction transistor 57 conducts, causing flip-flop 80 to reset as shown at 132 in waveform C.

When pulse 130 arrived and set flip-flop 80, time delay 114 began the timing cycle of that element, as indicated in waveform D. However, since flip-flop 80 reset before the time delay 114 was completed, its timing cycle terminated at 134. Operation is similar during the next three pulses 136, 138 and 140, since the spacing between these pulses is more than the minimum permissible speed. As a result, the time delay of time delay element 114 started anew upon the arrival of each of these pulses.

Pulse 142, on the other hand, arrived before capacitor 55 reached the point where unijunction transistor 57 conducts. This indicates that the speed of the character belt 12 is now above the minimum permissible speed. Arrival of pulse 142 at the input of time delay 82 caused transistor 51 to conduct and discharge capacitor 55 before unijunction transistor 57 conducted. Therefore, the output of time delay 82 never reached the logic 1 level so that flip-flop 80 remains set. Since flip-flop 80 remains set, time delay 114 (as indicated by waveform D) completed its timing cycle at 144. At this time, the underspeed detector 52 has indicated that the belt speed has reached the desired level and the system is ready to apply power to the hammer buss.

Power is not, however, instantaneously applied to the hammer buss since the application of power is synchronized with the synchronizing signal of waveform E. Since this waveform is the combined output of waveforms derived from the photocells 34, 36 in FIG. 1, the logic state of this waveform indicates when the hammer busses are permitted to be energized. Whenever waveform E is a logic 0, the hammer busses are permitted to be energized whereas the presence of a logic 1 at the E waveform indicates that hammer busses cannot be energized since the character belt fingers are not, at that time, in the proper position. In this way, the energization and deenergization of the hammer buss will be controlled by timing it with waveform E. That is, the hammer buss will be energized (or deenergized) when the waveform E switches from the logic 1 to the logic 0 level.

As was pointed out above, the output of time delay 114 went to logic 1 at 144. This occurred, however, when the output of waveform E was a logic 1 so that the hammer buss could not be energized at that time without risk of damage to the printer mechanism. Therefore, the flip-flop 116 which controls the energization of the hammer buss does not set at the precise time when time delay 114 completes its timing cycle. Instead, the setting of flip-flop 116 is delayed until the time shown at 146 when waveform E goes to logic 0 thereby triggering flip-flop 116 and energizing the hammer buss.

Having set flip-flop 116, the hammer buss is energized and will remain energized so long as the speed of the character belt stays higher than the minimum permissible speed established by time delay 82.

The waveforms of FIG. 3 following the broken lines illustrate the operation of the underspeed detector 52 when the speed falls below the minimum permissible speed so as to require deenergization of the hammer buss. The fact that the speed of the character belt is below the minimum permissible speed is indicated by the spacing of pulses 148 and 150 in the A waveform. At 152 the capacitor 55 in time delay 82 reaches the point where unijunction transistor 57 conducts. At this point, the flip-flop 80 is reset. However, the E waveform at this time is a logic 1 so that one of the hammers may be energized at this point. Therefore, power should not be removed from the hammer buss in order to prevent damaging the printer mechanism.

Damage to the print mechanism in this situation is prevented because the E waveform forms the second input to OR gate 110 in FIG. 2. Therefore, the fact that the output of flip-flop 80 changed to a logic 0 did not take effect in time delay unit 114 since the second input to OR gate 110 was a logic 1 at this time. Therefore, flip-flop 116 does not reset until the point indicated at 154 in the E waveform, at which time the output of OR gate 110 changes to a logic 0. Since the output of time delay 114 is fed through inverter 118 to the direct reset terminal R of flip-flop 116, flip-flop 116 immediately resets at this point and removes power from the hammer buss during the period of time in which the E waveform is a logic 0 so as to safely deenergize the hammer buss at a time when no hammers are being energized.

FIG. 4 illustrates the operation of the undervoltage portion of the embodiment of FIG. 2 in synchronously energizing and deenergizing the hammer buss. The effective DC output of the power supply in FIG. 2 is represented by waveform H. When the control system is initially energized, the effective DC voltage at H will rise at the exponential rate shown.

The voltage on the time delay circuit 90 in FIG. 2 is illustrated by the waveform I, which is similar to waveform H but delayed somewhat in time in order to accommodate the charging of capacitor 92 in that time delay circuit. At 160, the input voltage to the comparator 96 reaches the lower voltage limit at which time the output of the comparator 96 becomes a logic 1. When the output of the comparator 96 becomes a logic 1, the time delay of time delay unit 104 is initiated as indicated in waveform G. Following the time delay of time delay 104 (indicated at 162), the time delay of time delay unit 114 is initiated, as indicated by waveform D.

The time delay of time delay unit 114 terminates at the point indicated at 164. Hence, the undervoltage circuit has indicated at this time that the input voltage is above the lower voltage limit and the combined time delays of time delay units 104, 114 have provided sufficient time to allow the system to stabilize. However, it will be noted that the output of time delay unit 114 reached the logic 1 level when the E waveform was a logic 1. Therefore, it is not permitted to energize the hammer buss at 164 since energization of the hammer buss must be delayed until the next time the E waveform goes to logic 0. Thus, while the waveform D arrives at the logic 1 at 164, the hammer buss is not energized until 166 so as to ensure that the printer mechanism will not be damaged.

The function of the time delay circuit 90 in FIG. 2 is also illustrated in FIG. 4. Momentary droops in the input voltage are illustrated at 168 and 170. The undervoltage circuit of the present invention need not deenergize the hammer buss during such temporary droops in the power supply since filter capacitors (such as capacitor 72 in FIG. 2) are able to maintain the input voltage to the control system for a period of time sufficient to alleviate the effects of such temporary droops. Therefore, while the waveform H is shown as drooping somewhat at 168 and 170, the input to comparator 96, as illustrated by waveform I, does not feel the effects of these temporary droops by virtue of the action of the capacitor 92 in time delay unit 90.

The portion of FIG. 4 following the broken lines illustrates the operation of the undervoltage detector 50 when the input voltage drops below predetermined lower voltage limits. As can be seen in waveform H, the input voltage begins to fall at the point indicated at 172. The effect of the droop in input voltage is not immediately felt at the comparator 96 by virtue of the action of time delay 90, so that the I waveform is shown falling below the lower voltage limit at a later time indicated at 174. When the I waveform falls below the lower voltage limit, the output of time delay 104 (illustrated by the G waveform) simultaneously changes to logic 0. At this point, however, the E waveform is a logic 1 indicating that it is not permissible to deenergize the hammer buss. The hammer buss is, therefore not deenergized at this time since the E waveform forms the second input to OR gate 110. However, at 176 the E waveform changes to logic 0 at which time the flip-flop 116 is immediately reset so as to deenergize the hammer buss during the time when none of the hammers are permitted to be energized.

Although the present invention has been described with respect to a particular embodiment, the principles underlining this invention will suggest many additional modifications of this particular embodiment to those skilled in the art. Therefore, it is intended that the appended claims shall not be limited to the specific embodiment shown, but rather shall cover all such modifications as fall within the true spirit and scope of the present invention.

We claim:

1. A protection system for a printer having a plurality of movable characters and a plurality of electrically energizable hammers for engaging the characters comprising:

- a. indication means for indicating the speed of said characters;
- b. a speed reference generator for generating a speed reference signal indicative of the minimum permissible speed of said characters;
- c. speed detecting means operatively connected to said indication means and said speed reference generator for generating a signal when the speed of said characters is less than said speed reference;
- d. undervoltage detecting means for indicating when the input voltage to said printer is below a predetermined value;
- e. synchronizing means for generating an output signal indicating when the hammers are permitted to be energized; and
- f. deenergization means operatively connected to said speed detecting means, said undervoltage detecting means and said synchronizing means so as to synchronously deenergize the hammers at a time determined by the absence of an output from said synchronizing means in response to an output from said speed detecting means or said undervoltage means.

2. The protection system recited in claim 1 further comprising a hammer power buss for selectively energizing the hammers and wherein said deenergization means operates to deenergize said hammer power buss.

3. The protection system recited in claim 1 wherein said speed detecting means comprises a bistable device operatively connected to said indication means to assume a first state upon receipt of an input from said indication means and wherein said speed reference generator comprises time delay means operatively connected to said indication means to begin a timing cycle in response to receipt of said input from said indication means, the output of said time delay means being operatively connected to said bistable device so as to change the state of said bistable device at the end of said timing cycle.

4. The protection system recited in claim 1 wherein said undervoltage detecting means comprises a Zener diode operatively connected to said input voltage.

5. The protection system recited in claim 1 further comprising a second time delay circuit connected between said input voltage and said undervoltage detecting means so as

to desensitize said undervoltage detecting means from the effects of temporary variations in said input voltage.

6. The protection system recited in claim 1 wherein said synchronizing means comprises means for indicating the position of the movable characters.

7. A protection system for a printer having a plurality of characters on a moving belt and a plurality of electrically energizable hammers for mechanically engaging the characters so as to print the characters comprising:

- a. synchronizing means for generating a plurality of time-spaced pulses indicative of the position of the moving characters;
- b. speed detecting means operatively connected to said synchronizing means for indicating when the time between said pulses is greater than a predetermined fixed time so as to generate an output signal indicating an underspeed condition;
- c. undervoltage detecting means for indicating when the input voltage to said printer is below a predetermined value;
- d. a power buss for selectively energizing said hammers; and
- e. hammer buss control means operatively connected to said synchronizing means, said speed detecting means and said undervoltage detecting means for energizing said power buss synchronous with said synchronizing means in the absence of outputs from said speed detecting means and said undervoltage means, said hammer buss control means being further operative to deenergize said power buss synchronous with said synchronizing means in response to an output from said speed detecting means or said undervoltage detecting means.

8. The belt printer protection system recited in claim 7 wherein said synchronizing means comprises a photocell detector for sensing the position of the characters on the belt.

9. The system recited in claim 7 wherein said detecting means comprises a time delay means, a bistable element, said time delay responsive to receipt of normal voltage and normal speed conditions to produce a given time delayed signal, said element responsive to the simultaneous occurrence of a pulse from said synchronizing means and said time delay signal to set, means for removing said time delayed signal in response to an underspeed or undervoltage condition, said element responsive to removal of said time delayed signal and the absence of said synchronizing pulse to reset.

10. The belt printer control system recited in claim 7 wherein said undervoltage detecting means includes a Zener diode having a breakdown voltage corresponding to a predetermined minimum voltage and time delay means operatively connected between said input voltage and said Zener diode.

11. A method of protecting a printer having a plurality of movable characters and a plurality of electrically energizable hammers for engaging the characters comprising:

- a. indicating the speed of the moving characters;
- b. comparing the indicated speed of the characters with a predetermined lower speed limit;
- c. comparing the input voltage to the printer with a predetermined reference;
- d. deenergizing the print hammers at a time when the print hammers are not permitted to be energized if either the speed or voltage is below the predetermined limits.

12. The method of protecting a printer recited in claim 11 wherein the step of comparing the speed of the characters comprises comparing the time spacing of pulses indicating the speed of the characters with a fixed time delay.

13. The method of protecting a printer recited in claim 11 wherein the step of deenergizing the print hammers

comprising generating a signal indicating when the print hammers are permitted to be energized and then delaying the deenergization of the print hammers until the first time the generated signal is absent following an indication that the speed or voltage is below the predetermined limits.

14. A protection system for a printer having a plurality of movable characters and a plurality of recurrently, selectively electrically energizable hammers for engaging the characters comprising:

- a. means for providing a first signal only when the speed of said characters is different from a desired speed;
- b. means normally providing a second signal only when selected hammers are to be energized; and
- c. means responsive to said first signal and the absence of a second signal to prevent a subsequent recurrent energization of hammers.

15. A protection system for a printer having a plurality of movable characters and a plurality of recurrently, selectively, electrically energizable hammers for engaging the characters comprising:

- a. means for providing a first signal only when the speed of said characters is different from a desired speed;
- b. means for providing a second signal only when the input voltage to said printer is different from a desired value;
- c. means normally providing a third signal only when selected hammers are to be energized; and
- d. means responsive to at least one of said first and second signals and the absence of a third signal to prevent a subsequent recurrent energization of hammers.

16. A protection system for a printer having a plurality of characters on a moving belt and a plurality of recurrently, selectively electrically energizable hammers for mechanically engaging the characters so as to print the characters comprising:

- a. synchronizing means for generating a plurality of time-spaced pulses whose time occurrence is indicative of the position of the moving characters;
- b. means for providing a first signal only when the time between said pulses is different from a desired time to indicate an undesirable speed condition;
- c. means normally providing a second signal only when selected hammers are to be energized;
- d. means responsive to said first signal and the absence of a second signal to prevent a subsequent recurrent energization of hammers.

17. The belt printer protection system recited in claim 16 wherein the source of said first signal comprises a bistable device operatively connected to said synchronizing means to assume a first state in response to a pulse from said synchronizing means, time delay means operatively connected to said synchronizing means to begin a timing cycle in response to a pulse from said synchronizing means, the output of said delay means being operatively connected to said bistable device so as to change the state of said bistable device at the end of said timing cycle.

18. A protection system for a printer having a plurality of movable characters and a plurality of recurrently, selectively, electrically energizable printing elements for cooperating with the characters to effect printing:

- a. means for providing a first signal only when the speed of said characters is different from a desired speed;
- b. means normally providing a second signal only when selected printing elements are to be energized; and
- c. means responsive to said first signal and the absence of a second signal to prevent a subsequent energization of printing elements.

UNITED STATES PATENT OFFICE
CERTIFICATE OF CORRECTION

Patent No. 3,575,107 Dated April 13, 1971

Inventor(s) Earle B. McDowell and Clifford M. Jones

It is certified that error appears in the above-identified patent and that said Letters Patent are hereby corrected as shown below:

Column 3, line 11, cancel "Jun." and insert -- June ---. Column 4, line 40, after "be" insert -- a ---. Column 6, line 8, cancel "both" and insert -- both ---. Column 7, line 6, cancel "above" and insert -- above ---. Column 12, line 53, before "delay" insert -- time ---.

Signed and sealed this 28th day of March 1972.

(SEAL)
Attest:

EDWARD M. FLETCHER, JR.
Attesting Officer

ROBERT GOTTSCHALK
Commissioner of Patents