



Europäisches Patentamt
 European Patent Office
 Office européen des brevets



(11) **EP 1 180 564 A1**

(12) **EUROPEAN PATENT APPLICATION**

(43) Date of publication:
20.02.2002 Bulletin 2002/08

(51) Int Cl.7: **E04C 2/34**

(21) Application number: **01203007.8**

(22) Date of filing: **08.08.2001**

(84) Designated Contracting States:
**AT BE CH CY DE DK ES FI FR GB GR IE IT LI LU
 MC NL PT SE TR**
 Designated Extension States:
AL LT LV MK RO SI

(71) Applicant: **Snel Golfkarton B.V.**
1671 ND Medemblik (NL)

(72) Inventor: **Snel, Wilhelmus J.R.K.**
1657 AD Abbekerk (NL)

(30) Priority: **10.08.2000 NL 1015909**

(74) Representative: **Hooiveld, Arjen Jan Winfried
 Arnold & Siedsma Sweelinckplein 1
 2517 GK Den Haag (NL)**

(54) **Wall element at least substantially made of cellulose material**

(57) A wall element at least substantially made of cellulose material, comprising two outer layers extending at least substantially parallel to each other, between which an intermediate layer is provided, characterized

in that said intermediate layer extends between the outer layers in a zigzag fashion, wherein the parts of the intermediate layer that extend from one outer layer to the other are at least substantially flat.

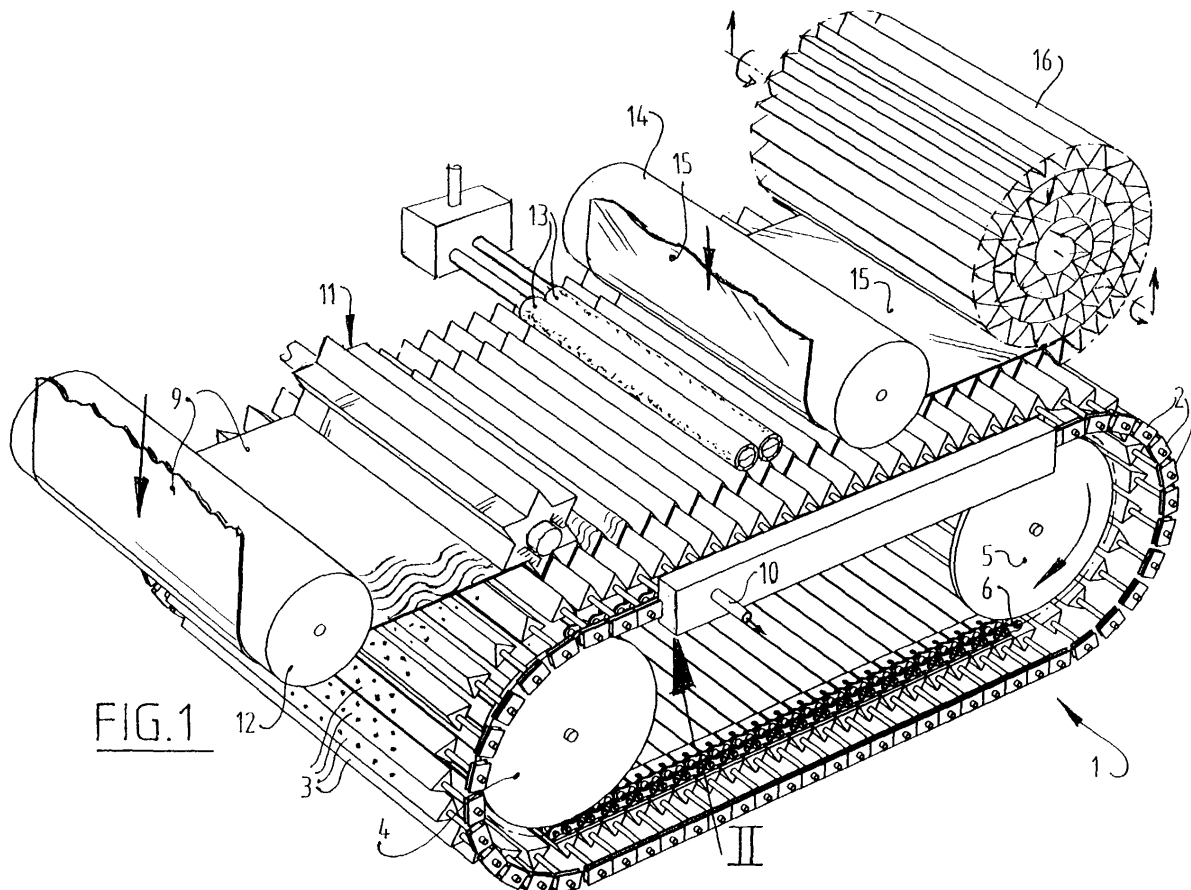

FIG. 1

EP 1 180 564 A1

Description

[0001] The invention relates to a wall element at least substantially made of cellulose material, comprising two outer layers extending at least substantially parallel to each other, between which an intermediate layer is provided. The invention furthermore relates to a method for manufacturing said wall element.

[0002] Such a wall element is known from German patent no. 2 026 768 (Universal Papertech Corp.). Said patent discloses a building which is built up of a many different constructional elements, such as a concrete floor, roof parts and side wall parts made of a corrugated board intermediate layer, which is sandwiched between two flat outer layers, as well as clamps and corner elements. In practice it has become apparent that the constructional strength of the roof parts and the side wall parts is insufficient to give the building the required strength.

[0003] The object of the invention is to improve the wall element that is known from the aforesaid German patent publication, in the sense that a wall element is provided which exhibits an optimum constructional stiffness for functioning as a constructional element of a building, as a wall panel in a partition, etc. It is noted that the term wall element is understood to include an element for a wall, a floor, a ceiling, a roof, etc.

[0004] In order to accomplish that objective, a wall element of the kind referred to in the introduction is characterized in that said intermediate layer extends between the outer layers in a zigzag fashion, wherein the parts of the intermediate layer that extend from one outer layer to the other are at least substantially flat. Research has shown that the present zigzag shape results in an unexpectedly great constructional stiffness of the wall element, so that the wall element can be exposed to large forces without losing its structural integrity. The constructional strength is additionally increased if the parts extending from one outer layer to the other extend at an angle of less than 90°, preferably between 30° and 75°, more preferably between 45° and 65°.

[0005] In one preferred embodiment of a wall element according to the invention, the parts extending from one outer layer to the other bound a flat portion of the intermediate layer, which abuts against an outer layer over a distance of 0 - 5 cm, preferably 0 - 3 cm, more preferably 0 - 2 cm. On the one hand the presence of the flat (intermediate) portion makes it possible to affix said portion to an outer layer, in order to increase the stiffness of the whole, but on the other hand, the distance over which the flat (intermediate) part is affixed to an outer layer in that case must remain within the indicated bounds, in order to prevent the whole from collapsing in an "accordion-like" fashion upon being loaded.

[0006] In another preferred embodiment of a wall element according to the invention, the parts extending from one outer layer to the other form a fold having a radius of less than 10 mm, preferably less than 5 mm,

with each other. In other words, the magnitude of radius of the bend between parts extending from one part of the outer layer to the other is within the indicated bounds, which contributes to an optimum strength of the wall element.

[0007] In another preferred embodiment of a wall element according to the invention, said intermediate layer is at least substantially made of a material selected from the group of corrugated cardboard, massive cardboard and wood.

[0008] In another preferred embodiment of a wall element according to the invention, said outer layers are at least substantially made of a material selected from the group of corrugated cardboard, massive cardboard and wood. In particular, said intermediate layer and/or said outer layers is (are) at least substantially made of corrugated cardboard exhibiting a crimped surface profile, so that said intermediate layer and/or said outer layers can hardly be deformed, if at all, in any direction along their surface.

[0009] Preferably, said intermediate layer is formed of layers of paper/cardboard, wherein each layer is at least substantially made up of a corrugated sublayer and a flat sublayer affixed to one side thereof, wherein said paper/cardboard layers are interconnected via an adhesive, in particular a glue, which is present on the ridges of the corrugated sublayers. In a special embodiment, said intermediate layer can also be made up of a corrugated sublayer, wherein the two flat sublayers and the corrugated sublayer present therebetween are interconnected by means of an adhesive, in particular a glue, which is present on the ridges of said corrugated sublayer. In a preferred variant, also said outer layers are made up formed of layers of paper/cardboard, wherein each layer comprises a corrugated sublayer and a flat sublayer present on one side thereof, wherein an adhesive which is present on the ridges of the corrugated sublayers provides the interconnection of the paper/cardboard layers. In another preferred variant, said outer layers are made of wood. In yet another preferred variant, said outer layers are each made up of a gypsum board, which is built up of two paper/cardboard external layers, with an internal gypsum layer present therebetween. Said gypsum board can be connected to the intermediate layer of the present wall element either directly or with the interposition of a paper/cardboard layer, as will be explained yet hereinafter with reference to the drawing.

[0010] It is noted that the term paper is used for lighter sorts of paper, whilst the term cardboard is frequently used for heavier classes of paper. Within the framework of the invention no restriction as regards the sort of material is intended when the terms paper or cardboard and weight are used.

[0011] In another preferred embodiment of a wall element according to the invention, said wall element is arranged for accommodating piping, cables and the like and/or insulation material and/or stiffening material in

the intermediate layer thereof. In itself the present wall element exhibits an ideal thermal insulation, on account of the relatively large air cavities in the zigzag intermediate layer, but said cavities can also be utilized, partially or entirely, for accommodating piping, cables and tubes or for insulation and/or stiffening material.

[0012] The invention furthermore relates to a method for manufacturing a wall element according to the invention, which method comprises the steps of:

- pressing a strip of a starting material, which is at least substantially made of cellulose, against a mould having a zigzag surface for the purpose of pressing a zigzag shape in said strip of starting material so as to form the intermediate layer;
- subsequently affixing the outer layers, which are at least substantially made of cellulose, to both sides of the intermediate layer.

[0013] Preferably, the intermediate layer is affixed to a carrier as a semi-finished product. This makes it possible to roll up the whole of intermediate layer and carrier into a roll and affix the outer layers to the intermediate layer at a later stage.

[0014] In one preferred embodiment of a method according to the invention, the strip of starting material is positioned relative to the mould by means of an underpressure between the strip of starting material and the mould.

[0015] The invention furthermore relates to a device for carrying out a method according to the invention, wherein a mould having a zigzag surface is provided.

[0016] The invention will now be explained in more detail by means of preferred variants of the invention as shown in a drawing, wherein:

- Figures 1 and 3 are schematic, perspective views of two embodiments of a device according to the invention for manufacturing a wall element according to the invention;
- Figure 2 shows a detail of Figure 1;
- Figures 4 - 7 are schematic, perspective views of various embodiments of wall elements according to the invention;
- Figures 8 and 9 relate to two ways of connecting a wall element according to the invention to a structural section;
- Figures 10 and 11 show to further embodiments of a wall element according to the invention; and
- Figure 12 is a schematic, perspective view of a building which is built up of wall elements according to the invention.

[0017] Figure 1 shows a mould 1 according to the invention, comprising an endless, circulating belt 2, on which belt elements 3 of triangular cross-section are present. Mould 1 furthermore comprises two driving rollers 4, 5 for driving a chain 6, which is connected to belt

2 via pins 7, and which consequently drives said belt. As is shown in more detail in Figure 2, pins 7 support the belt elements 3, whereby the latter are hollow and provided with perforations 8 on their outer surface. This makes it possible to position a strip of corrugated cardboard 9 from a supply roll (not shown) precisely with respect to belt 2, whereby an underpressure (in particular a vacuum) is generated in the hollow belt elements 3 via a pipe 10 so as to press/suck the strip of corrugated cardboard down onto belt 2, as it were. As is shown in Figure 1, a rotary pressure element 11 of a star-shaped cross-section is used to press the strip of corrugated cardboard 9, which is moved past a hold-down roller 12, down on the belt 2 of the mould 1 with a suitable force and thus press a zigzag shape corresponding to the outer surface of the mould 1 into the strip of corrugated cardboard 9. The strip of corrugated cardboard 9 in its final zigzag shape forms an intermediate layer of a wall element according to the invention, as will be explained in more detail hereafter. Once the zigzag intermediate layer has been formed, corrugated cardboard outer layers can directly be glued to both sides thereof, if desired. If the zigzag intermediate layer is stored as a semi-finished product, however, it is first glued, by means of glue rollers 13, to a paper carrier 15 from a storage roll (not shown), which is carried past a hold-down roller 14, after which the whole is wound into a roll 16. At a later stage, said zigzag intermediate layer can be detached from carrier 15 and corrugated cardboard outer layers can be glued to both sides thereof. In Figure 2, those parts that correspond to parts shown in Figure 1 are indicated by the same numerals.

[0018] Figure 3 schematically show the aforesaid strip of corrugated cardboard 9 of Figure 1, in which folding or bending lines 18 are first formed, as a pre-operation, by means of a cutting die 17 in order to make it possible to give the strip of corrugated cardboard 9 its zigzag shape without using the mould 1. To this end, the strip of corrugated cardboard 9, once it has undergone the cutting operation, is moved along a guideway 19, which converges in the direction of movement of the strip of corrugated cardboard 9. Due to the natural weakness of the material of the corrugated cardboard, the folding lines 18 and the tapered or conical shape of the guideway 19, the zigzag shape is automatically obtained in the strip of corrugated cardboard 9, as it were. In order to realise a controlled guidance of the strip of corrugated cardboard 9, guide wheels 20 are used. After the formation of the zigzag intermediate layer, the aforesaid corrugated cardboard outer layers 21 are glued to both sides thereof.

[0019] Figures 4, 5 and 6 are perspective views of various types of wall elements 22 according to the invention, wherein each type comprises a zigzag intermediate layer 23 consisting of a corrugated sublayer, to both sides of which a flat sublayer is affixed. As Figures 4, 5 and 6 show, the parts 23' of the intermediate layer 23 that extend from one outer layer to the other are flat, so

as to give the wall elements 22 an optimum strength. The outer layers 21 of the wall elements 22 of Figures 4, 5 and 6 are each built up of several layers of cardboard, each layer consisting of a corrugated sublayer and a flat layer glued to one side thereof by means of a glue applied to the ridges of the corrugated sublayer. Wall element 22 of Figure 6 is curved, with pipes 24 being passed through the intermediate layer 23 thereof, whilst the outer layers 21, just like the outer layers of wall element 22 of Figure 5, are in fact formed by using a winding process wherein one outer layer 21 is wound around the intermediate layer 23 several times.

[0020] Figure 7 is a perspective view of another variant of a wall element 22 according to the invention, which clearly shows that the intermediate layer 23 is built up of a corrugated sublayer 27 which is sandwiched between flat sublayers 25, 26, whilst the outer layers 21 comprise three glued-together layers of corrugated cardboard, which are each built up of a corrugated sublayer and a flat sublayer affixed to one side thereof, wherein glue is present on the corrugations of the corrugated sublayer. Depending on the required strength, it is also possible to form the intermediate layer 23 and/or the outer layers 21 of more layers than in the illustrated example. The parts 23' of the intermediate layer 23 that extend from one outer layer 21 to the other bound a flat portion 23" of the intermediate layer 23, which flat portion 23" abuts against the respective outer layer 21 over a distance of 2 cm, in this embodiment, and which is glued together therewith.

[0021] A wall element 22 according to the invention can readily be used in a building structure, wherein the wall element 22 is inserted into a metal H-section 28 (Figure 8), for example, or into a metal section 29 having a more complex shape (Figure 9). The wall element 22 of Figure 9 is filled with insulation material 30. It is also possible to use a strengthening material instead of such insulation material.

[0022] Figure 10 relates to a preferred variant according to the invention, wherein a wall element 22, for example the wall element that is shown in Figure 4, 5, 6 or 7, comprises a gypsum plate 31 on both sides, which is affixed thereto. Since the gypsum plates 31 are offset with respect to wall element 22, as it were, the whole, which functions as a constructional element, comprises a through channel 32 at one end side and a projecting part 33 of wall element 22 at the other end side, so that such constructional elements can be easily interconnected by inserting the projecting part 33 of one constructional element into the through channel 32 of the other constructional element. Figure 11 corresponds to Figure 10, with parts corresponding to parts shown in Figure 10 being indicated by the same numerals, but wherein the intermediate layer 23 is directly connected to the gypsum plates 31 on both sides, that is, without the additional outer layers of Figure 10 being used. In that case, the paper/cardboard outer layers of the gypsum plates 31 that face towards the intermediate layer

function as the "outer layer" 21 for the intermediate layer 23", as is shown in Figure 11. Instead of forming the wall element 22 with a projecting part on one side (Figure 10), it is also possible, of course, to use a separate beam 34 (Figure 11), for example made of wood, which projects from between the gypsum plates 31.

[0023] Figure 12 is a perspective view of a building, wherein wall elements 22 form the eventual walls 35, a floor 36 and a (curved) ceiling 37. Use is made of sections 28 thereby, which sections are so configured that the wall elements 22 can readily be received therein, for example by sliding.

15 Claims

1. A wall element at least substantially made of cellulose material, comprising two outer layers extending at least substantially parallel to each other, between which an intermediate layer is provided, **characterized in that** said intermediate layer extends between the outer layers in a zigzag fashion, wherein the parts of the intermediate layer that extend from one outer layer to the other are at least substantially flat.
2. A wall element according to claim 1, wherein the parts extending from one outer layer to the other extend at an angle of less than 90°, preferably between 30° and 75°, more preferably between 45° and 65°.
3. A wall element according to claim 1 or 2, wherein the parts extending from one outer layer to the other bound a flat portion of the intermediate layer, which abuts against an outer layer over a distance of 0 - 5 cm, preferably 0 - 3 cm, more preferably 0 - 2 cm.
4. A wall element according to claim 1, 2 or 3, wherein the parts extending from one outer layer to the other form a fold having a radius of less than 10 mm, preferably less than 5 mm, with each other.
5. A wall element according to any one of the preceding claims 1 - 4, wherein said intermediate layer is at least substantially made of a material selected from the group of corrugated cardboard, massive cardboard and wood.
6. A wall element according to any one of the preceding claims 1 - 5, wherein said outer layers are at least substantially made of a material selected from the group of corrugated cardboard, massive cardboard and wood.
7. A wall element according to claim 5 or 6, wherein said intermediate layer and/or said outer layers is (are) at least substantially made of corrugated card-

board exhibiting a crimped surface profile.

8. A wall element according to any one of the preceding claims 1 - 7, wherein said wall element is arranged for accommodating piping, cables and the like and/or insulation material and/or stiffening material in the intermediate layer thereof. 5
9. A method for manufacturing a wall element according to any one of the preceding claims 1 - 8, which method comprises the steps of: 10
- pressing a strip of a starting material, which is at least substantially made of cellulose, against a mould having a zigzag surface for the purpose of pressing a zigzag shape in said strip of starting material so as to form the intermediate layer; 15
 - subsequently affixing the outer layers, which are at least substantially made of cellulose, to both sides of the intermediate layer. 20
10. A method according to claim 9, wherein folding lines are formed in the strip of starting material prior to pressing said strip against the mould. 25
11. A method according to claim 9 or 10, wherein the intermediate layer is affixed to a carrier as a semi-finished product. 30
12. A method according to claim 9, 10 or 11, wherein the strip of starting material is positioned relative to the mould by means of an underpressure between the strip of starting material and the mould. 35
13. A device for carrying out a method according to any one of the preceding claims 9 - 12, comprising a mould having a zigzag surface. 40

40

45

50

55

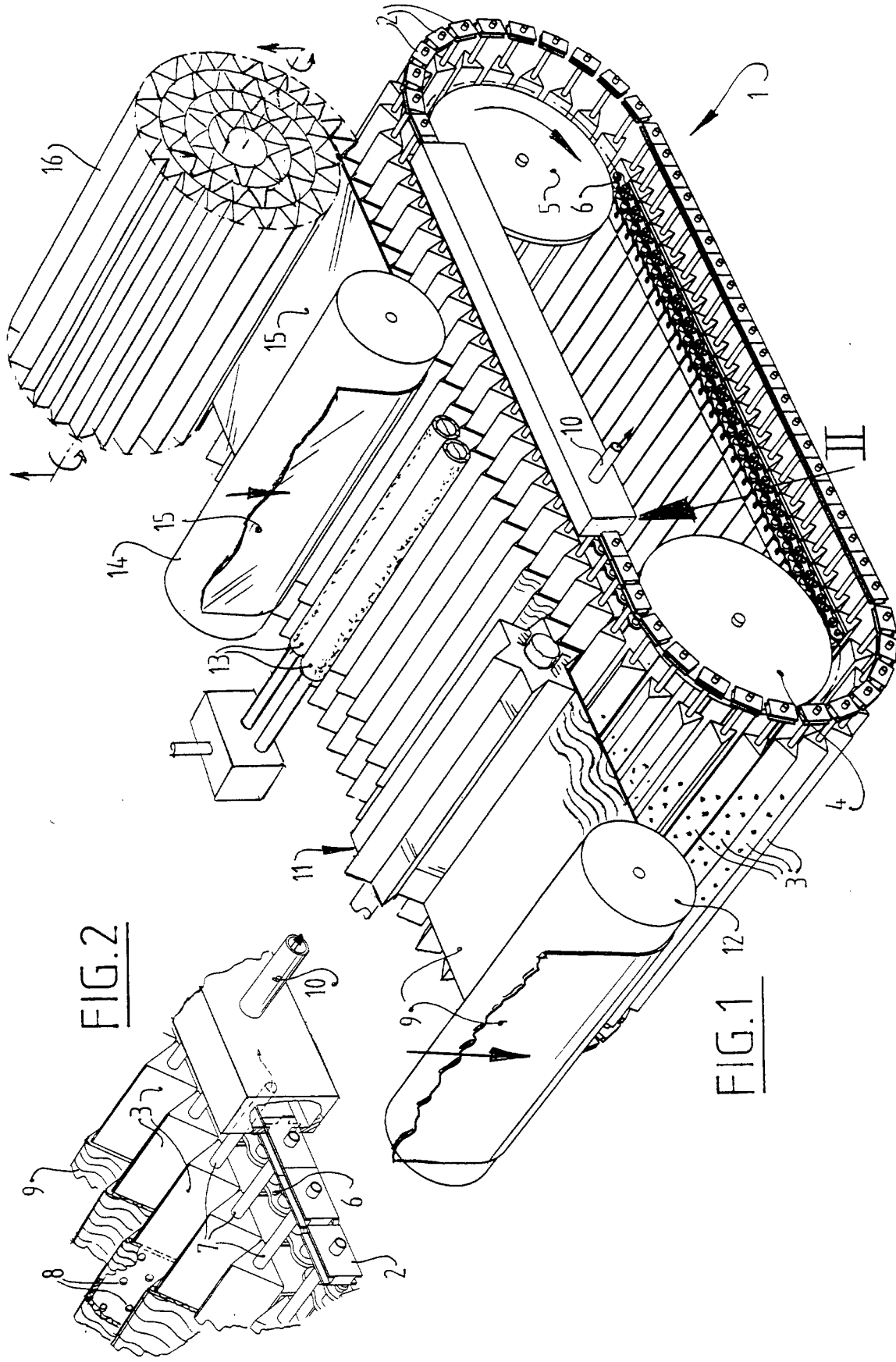
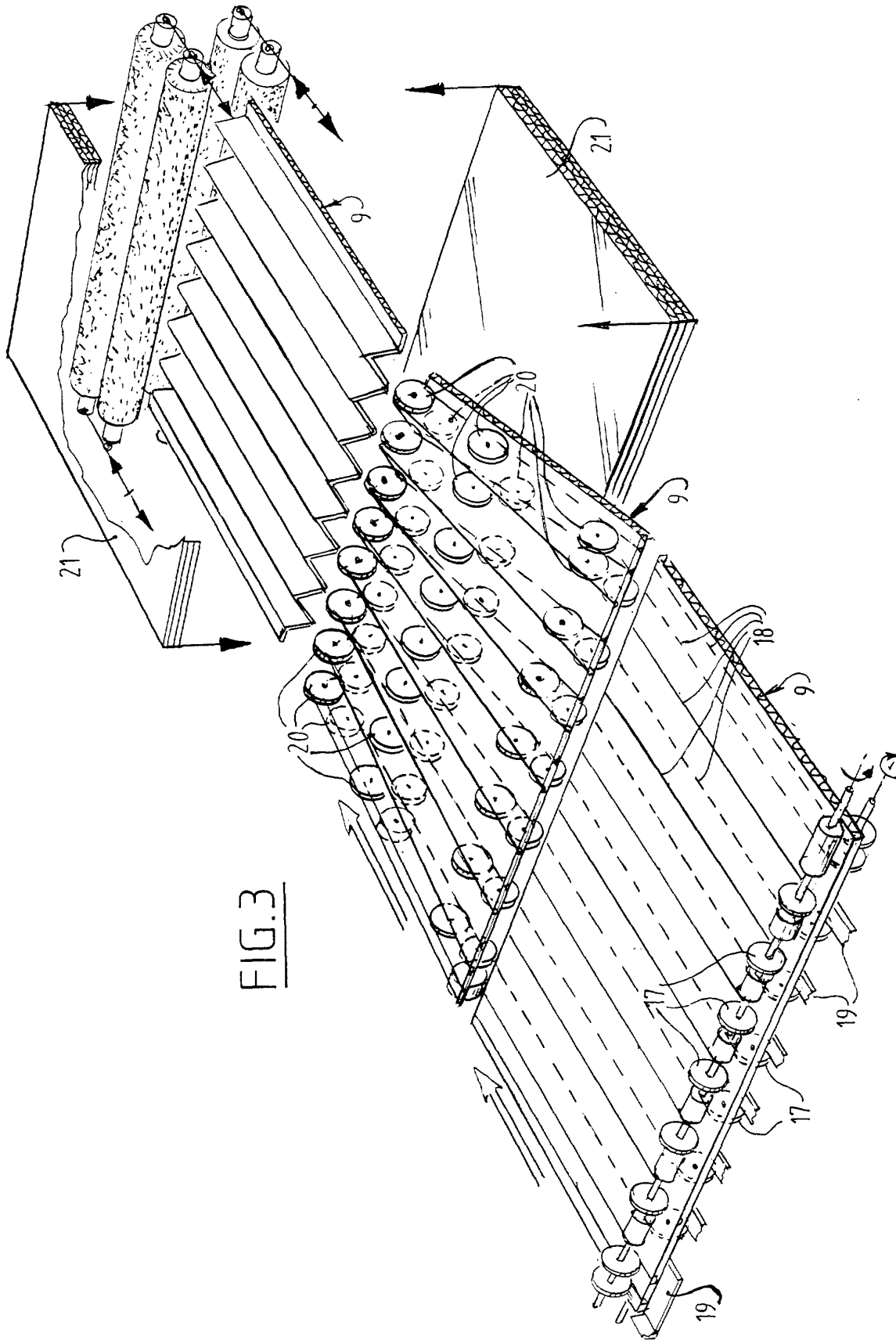
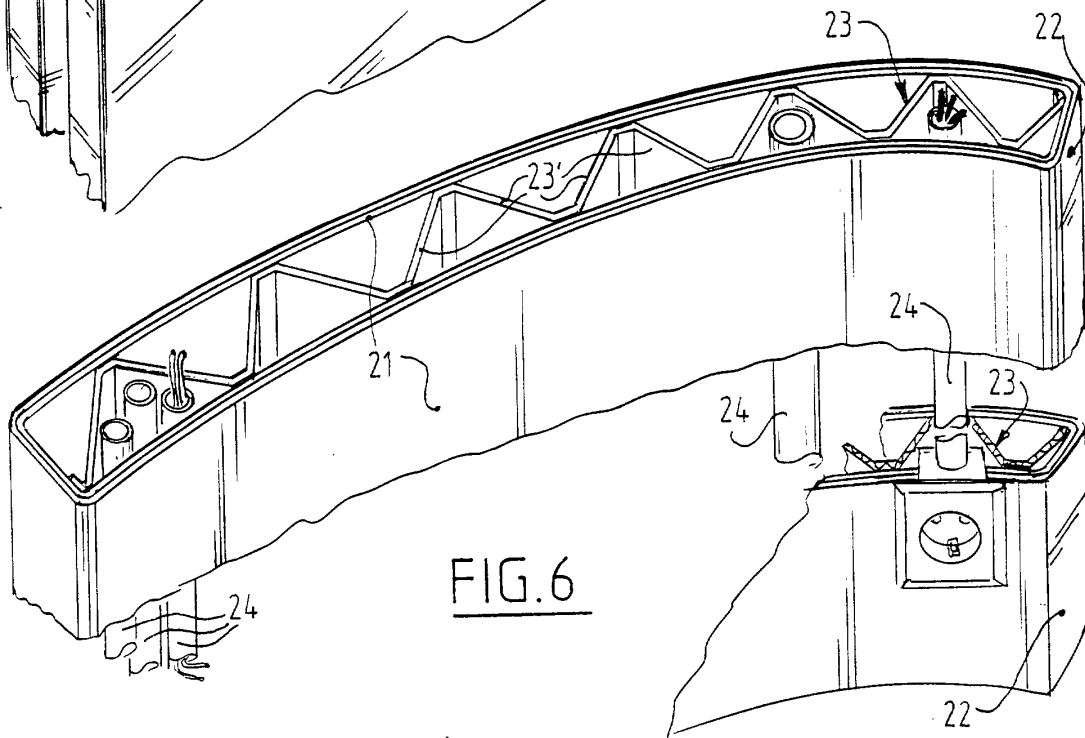
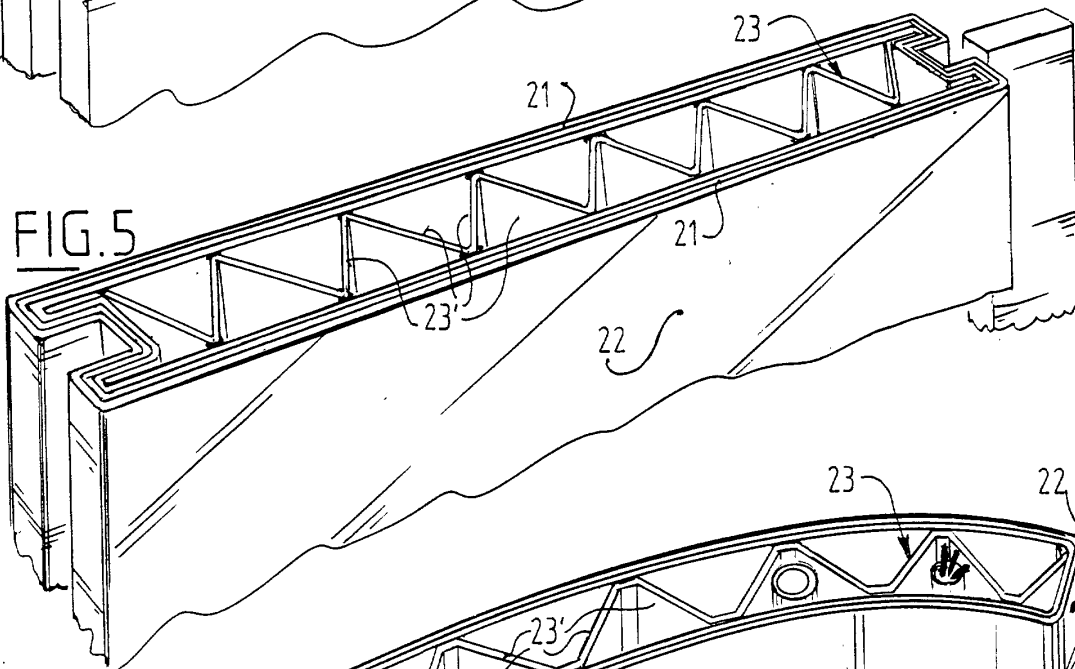
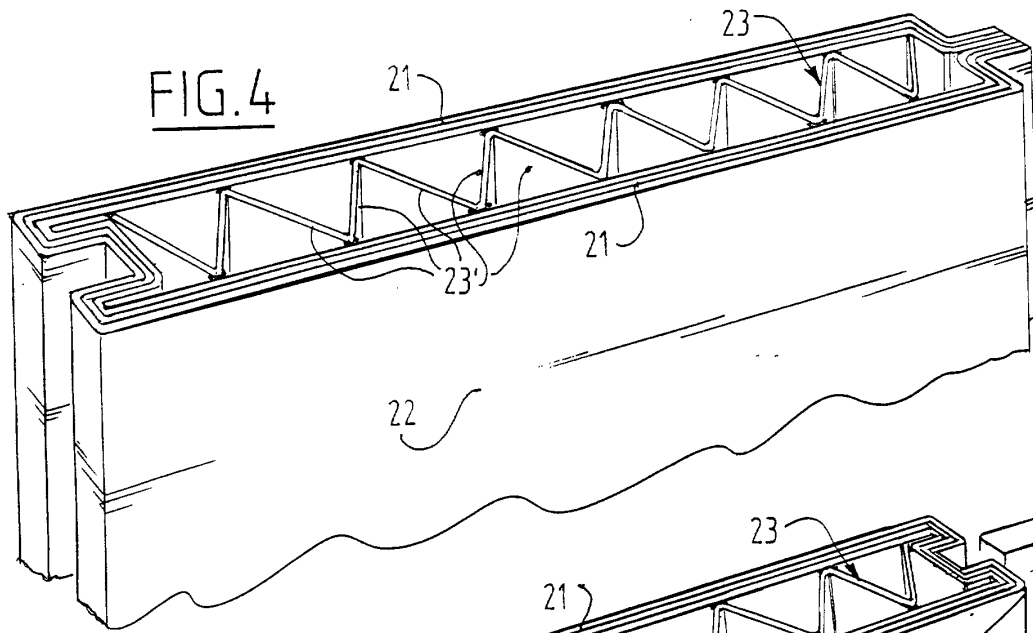

FIG. 2

FIG. 1





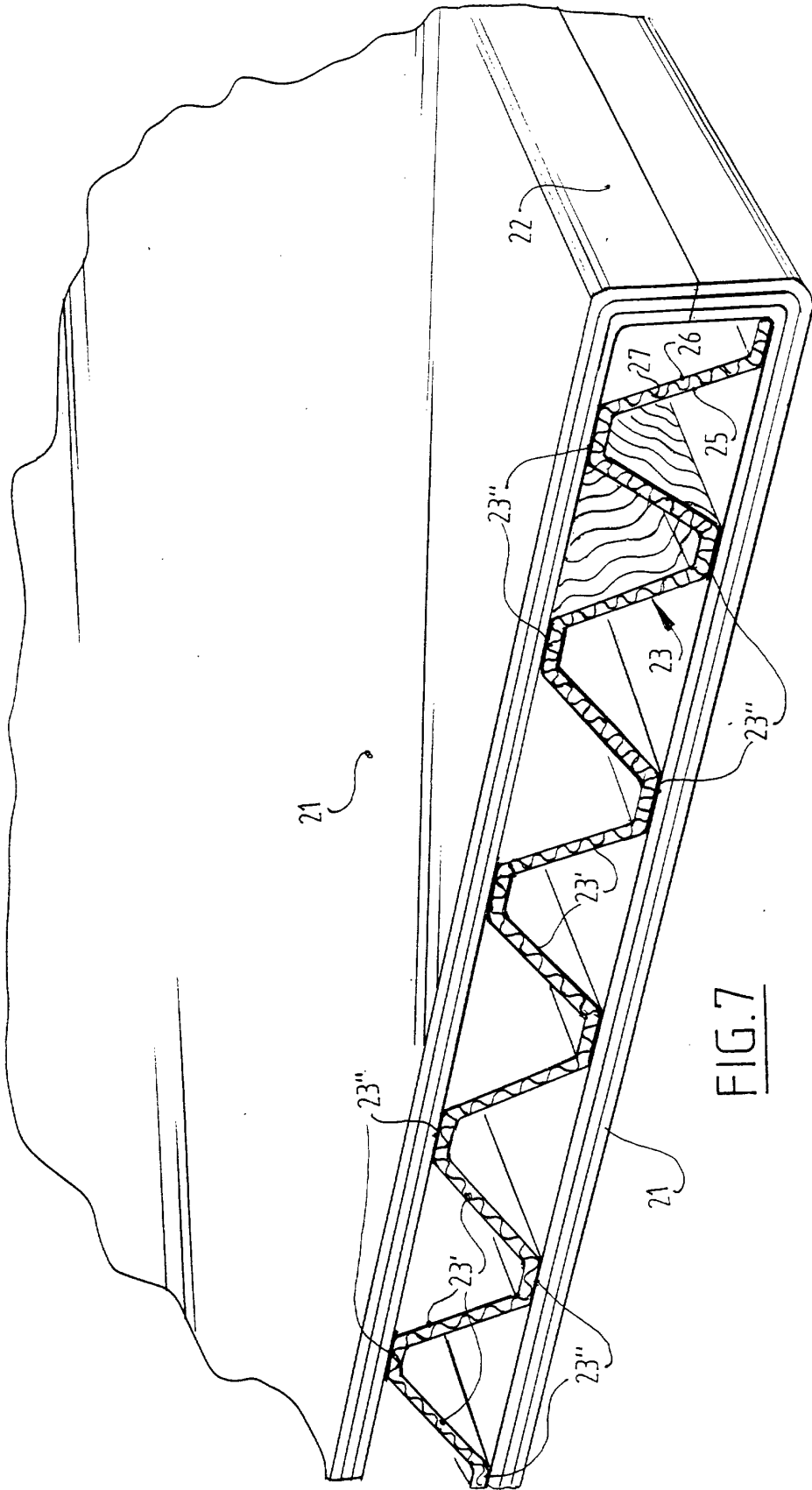

FIG. 7

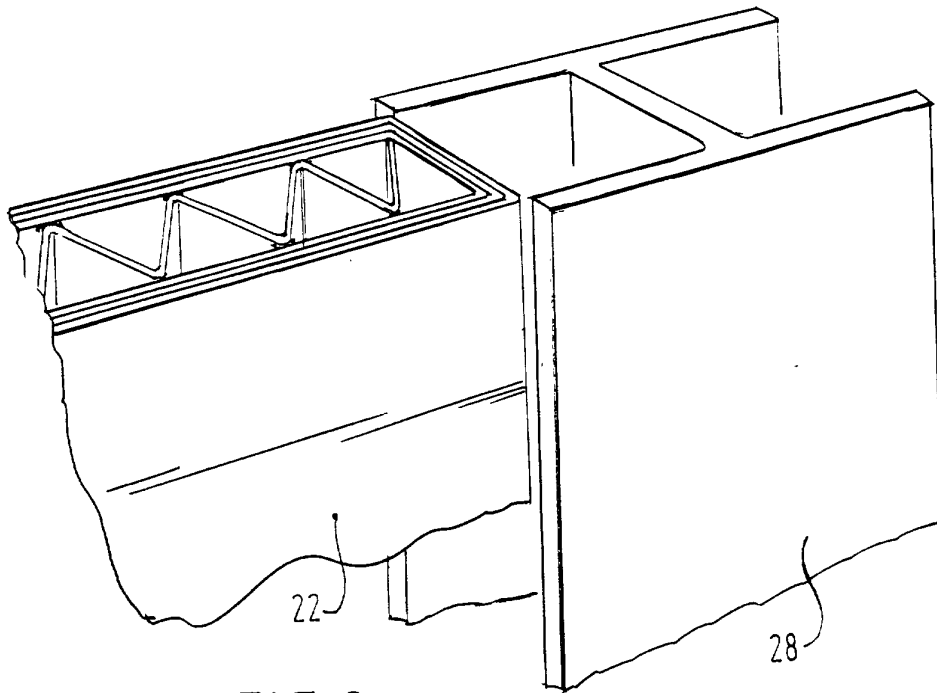

FIG. 8

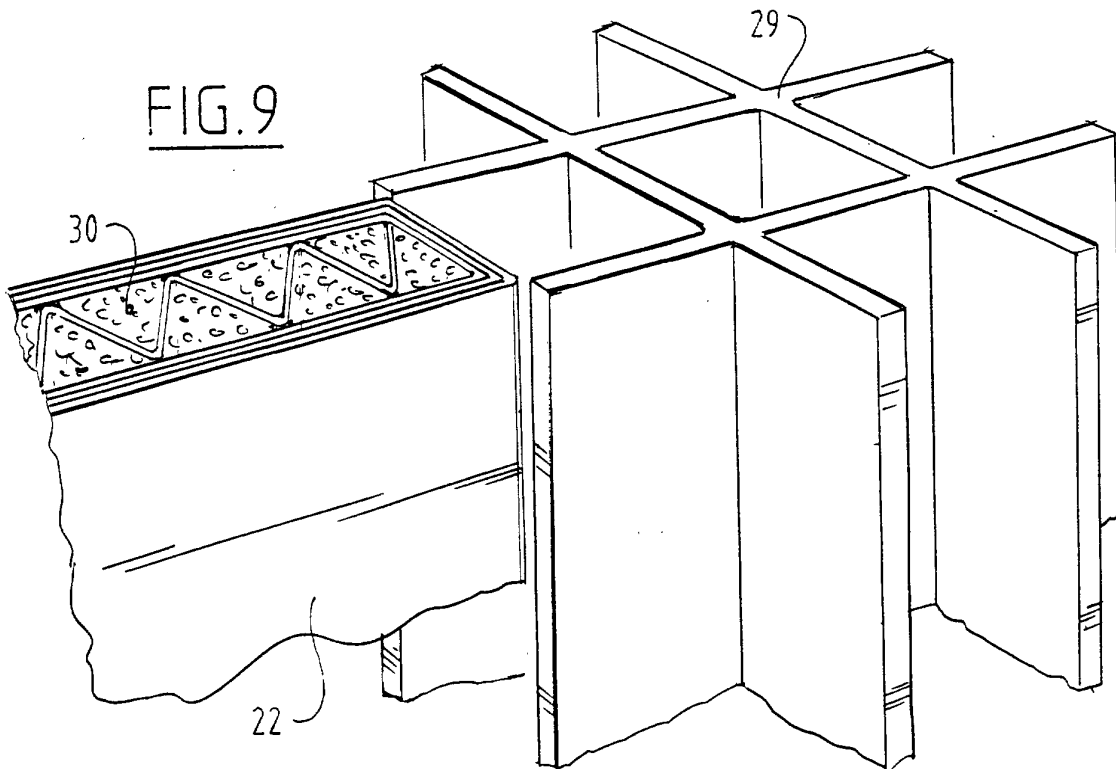

FIG. 9

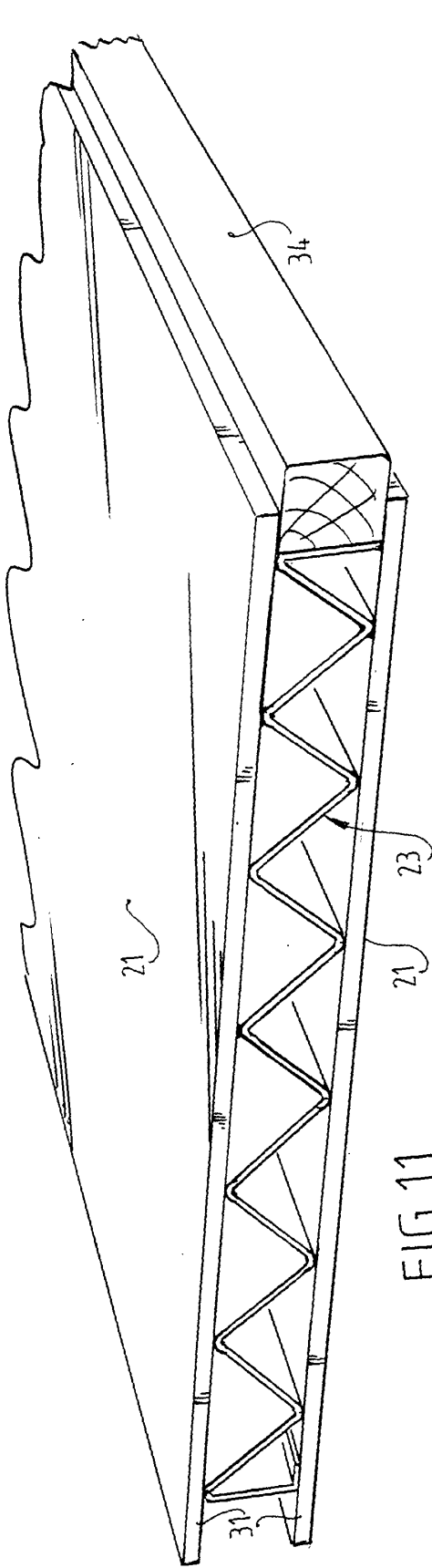

FIG. 11

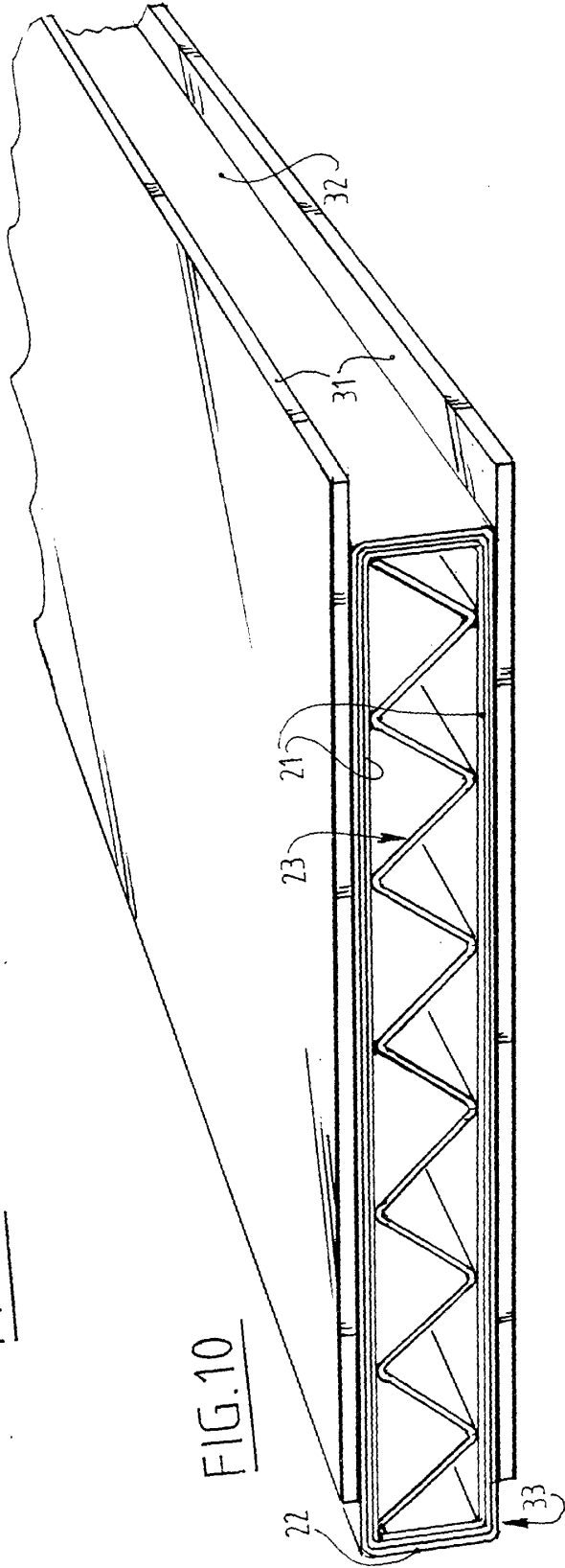
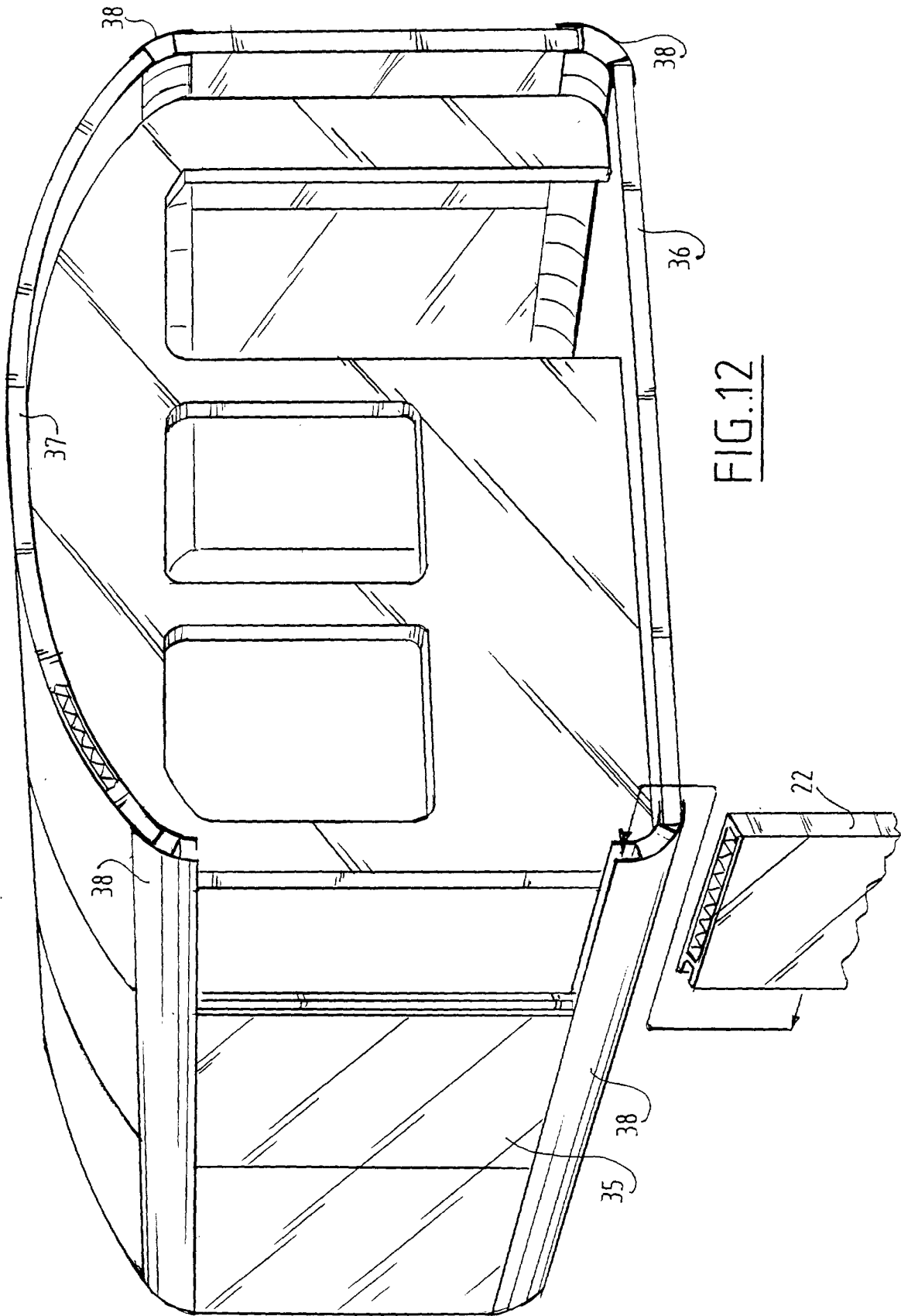

FIG. 10





European Patent
Office

EUROPEAN SEARCH REPORT

Application Number
EP 01 20 3007

DOCUMENTS CONSIDERED TO BE RELEVANT			
Category	Citation of document with indication, where appropriate, of relevant passages	Relevant to claim	CLASSIFICATION OF THE APPLICATION (Int.Cl.7)
X	DE 23 49 436 A (BALTZER) 10 April 1975 (1975-04-10)	1-3,5-7	E04C2/34
Y	* the whole document *	8	
Y	DE 21 51 750 A (SASSAIN) 26 April 1973 (1973-04-26) * figure 1 *	8	
X	EP 0 794 050 A (CARTONNESRIES DE LA LYS ONDULYS) 10 September 1997 (1997-09-10) * column 7, line 4 - column 10, line 22; figures 1-6 *	9,10,13	
The present search report has been drawn up for all claims			TECHNICAL FIELDS SEARCHED (Int.Cl.7)
			E04C B65D
Place of search	Date of completion of the search	Examiner	
THE HAGUE	21 November 2001	Mysliwetz, W	
CATEGORY OF CITED DOCUMENTS		T : theory or principle underlying the invention E : earlier patent document, but published on, or after the filing date D : document cited in the application L : document cited for other reasons & : member of the same patent family, corresponding document	
X : particularly relevant if taken alone Y : particularly relevant if combined with another document of the same category A : technological background O : non-written disclosure P : intermediate document			

EPC FORM 1503-03-92 (P04C01)

**ANNEX TO THE EUROPEAN SEARCH REPORT
ON EUROPEAN PATENT APPLICATION NO.**

EP 01 20 3007

This annex lists the patent family members relating to the patent documents cited in the above-mentioned European search report. The members are as contained in the European Patent Office EDP file on
The European Patent Office is in no way liable for these particulars which are merely given for the purpose of information.

21-11-2001

Patent document cited in search report		Publication date		Patent family member(s)	Publication date
DE 2349436	A	10-04-1975	DE	2349436 A1	10-04-1975
DE 2151750	A	26-04-1973	DE	2151750 A1	26-04-1973
EP 794050	A	10-09-1997	EP	0794050 A1	10-09-1997

EPC FORM P0469

For more details about this annex : see Official Journal of the European Patent Office, No. 12/82