



US00D957465S

(12) **United States Design Patent** (10) **Patent No.:** **US D957,465 S**  
**Tafe** (45) **Date of Patent:** **\*\* Jul. 12, 2022**

(54) **INTERCOOLER FOR AUTOMOTIVE APPLICATIONS**  
(71) Applicant: **Resource Intl Inc.**, New Castle, DE (US)  
(72) Inventor: **Dan Tafe**, Newark, DE (US)  
(73) Assignee: **Resource Intl Inc.**, New Castle, DE (US)  
(\*\*) Term: **15 Years**  
(21) Appl. No.: **29/755,062**  
(22) Filed: **Oct. 16, 2020**  
(51) **LOC (13) Cl.** ..... **15-01**  
(52) **U.S. Cl.**  
USPC ..... **D15/5**  
(58) **Field of Classification Search**  
USPC ..... D15/1, 2, 3, 4, 5, 6  
CPC ..... F02B 29/0425; F02B 29/0412; F02B 29/0437; F02B 29/0443; F02B 29/045; F02B 29/0406; F02B 29/0431; F28D 7/0066; F28D 1/0408; F28D 7/1653; F28F 1/04; F28F 1/12; F28F 9/02; F28F 21/02; B60H 1/14; B60H 1/3211; B60H 1/00271; B60H 1/3205; B60H 1/00342; F01P 11/08; B21D 53/08; F02M 26/27; F02M 26/31; F02M 35/10268  
See application file for complete search history.

2012/0024511 A1\* 2/2012 Harada ..... F28D 1/05366 165/181  
2012/0138025 A1\* 6/2012 Yoon ..... F02B 29/0456 123/563  
2016/0176284 A1\* 6/2016 Nugteren ..... F02B 37/16 180/68.3  
2017/0122186 A1\* 5/2017 Park ..... F02B 29/0412  
2017/0254257 A1\* 9/2017 Park ..... B60H 1/3211  
2018/0178677 A1\* 6/2018 Swain ..... F02M 35/048  
2019/0078501 A1\* 3/2019 Lee ..... F02M 26/27  
2019/0292979 A1\* 9/2019 Hlavac ..... F28D 7/0066  
2020/0040810 A1\* 2/2020 Uehane ..... F02B 37/16  
2020/0182205 A1\* 6/2020 Moyer ..... F02M 35/024  
(Continued)

**FOREIGN PATENT DOCUMENTS**

DE 102009036745 A1\* 2/2011 ..... F02B 29/0431  
DE 102011080204 A1\* 2/2013 ..... F02B 29/04  
(Continued)

*Primary Examiner* — Ania Aman  
(74) *Attorney, Agent, or Firm* — Condo Roccia Koptiw LLP

(57) **CLAIM**  
The ornamental design for an intercooler for automotive applications, as shown and described.

**DESCRIPTION**

FIG. 1 is a top front perspective view of the intercooler showing my new design;  
FIG. 2 is a front elevation view thereof;  
FIG. 3 is a rear elevation view thereof;  
FIG. 4 is a right elevation view thereof;  
FIG. 5 is a left elevation view thereof;  
FIG. 6 is a top plan view thereof; and,  
FIG. 7 is a bottom plan view thereof.  
The broken lines shown in the drawings illustrate portions of the intercooler for automotive applications that form no part of the claimed design.

**1 Claim, 4 Drawing Sheets**

(56) **References Cited**  
**U.S. PATENT DOCUMENTS**  
D920,382 S \* 5/2021 Tafe ..... D15/5  
2005/0189096 A1\* 9/2005 Wilson ..... H01L 23/473 257/E23.098  
2008/0271722 A1\* 11/2008 Grunewald ..... F28F 21/083 123/568.12  
2009/0314483 A1\* 12/2009 Kalbacher ..... F02B 29/0456 165/185

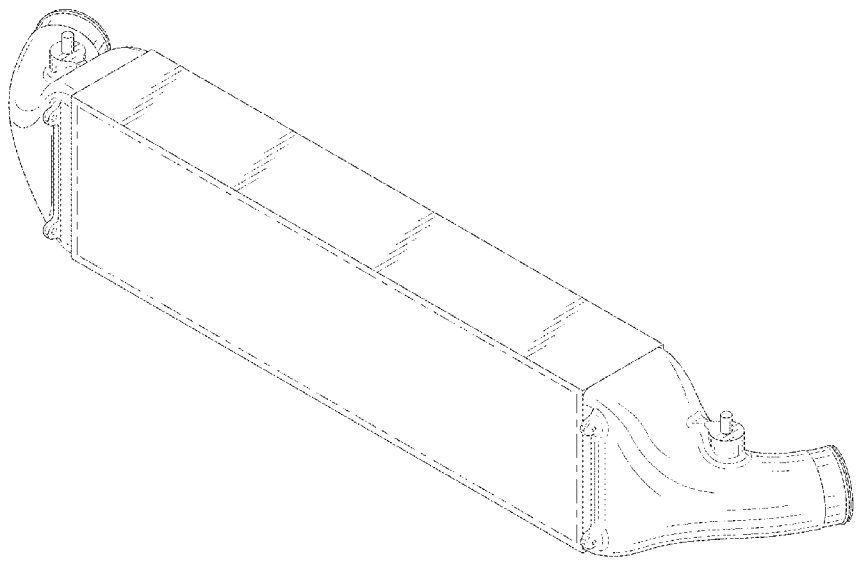

(56)

**References Cited**

U.S. PATENT DOCUMENTS

2020/0347774 A1\* 11/2020 Barrios ..... F02B 29/0418  
2020/0370466 A1\* 11/2020 Yang ..... F28D 7/1684  
2021/0331579 A1\* 10/2021 Usuki ..... B60L 50/50

FOREIGN PATENT DOCUMENTS

EP            1512853 A2 \* 3/2005 ..... F02B 29/0418  
GB            6082519     \* 2/2020  
JP            2009180482 A \* 8/2009

\* cited by examiner

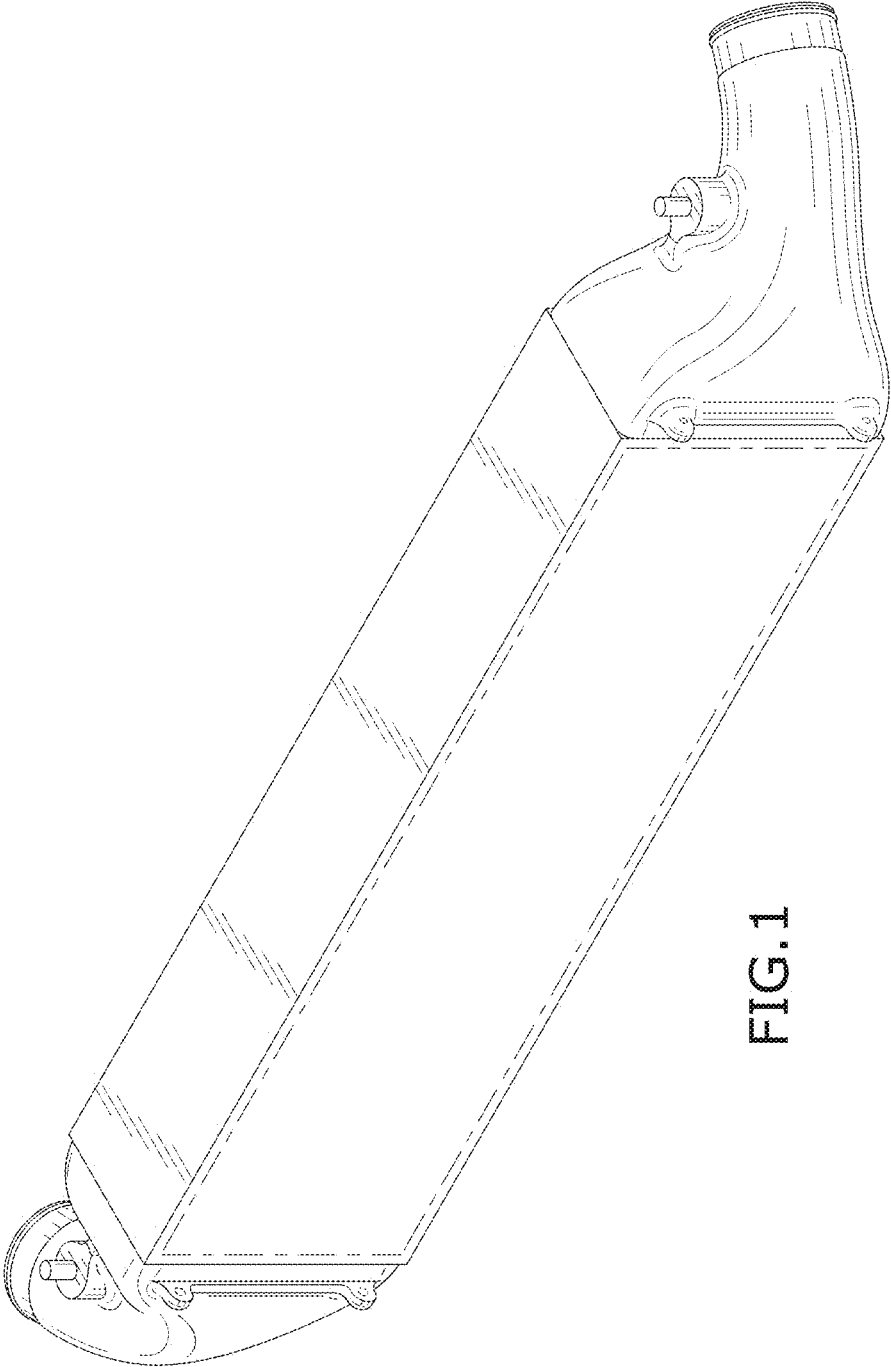

FIG. 1

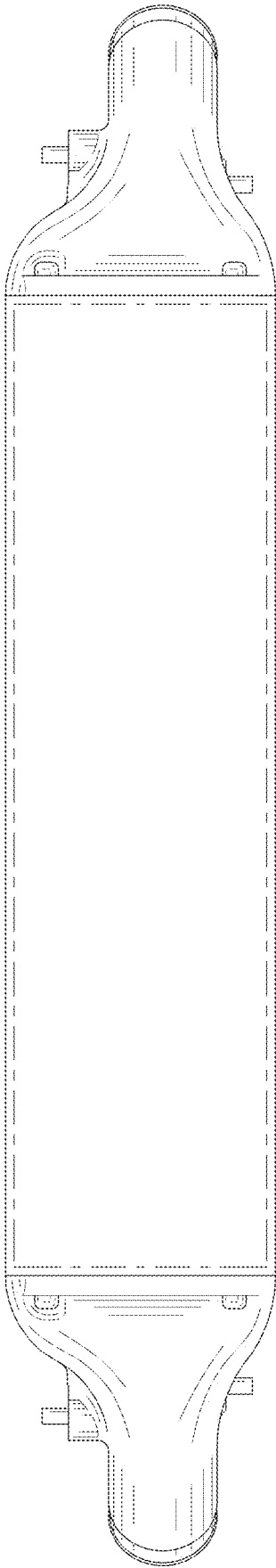

FIG. 2

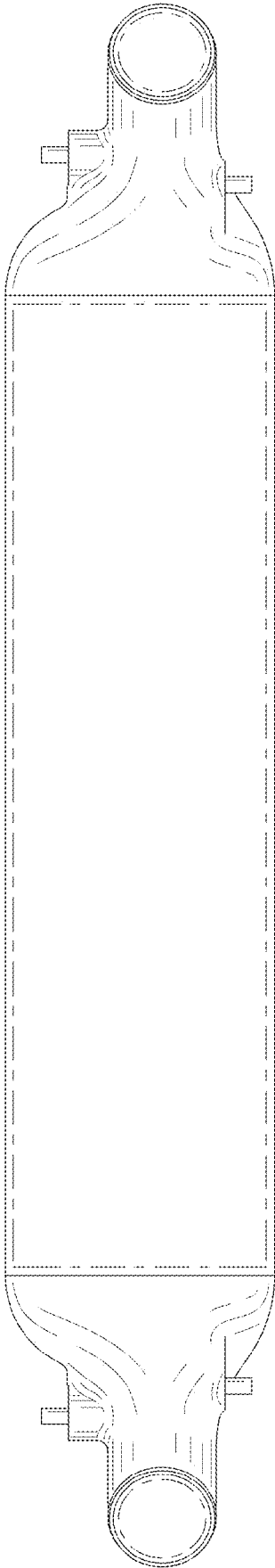

FIG. 3

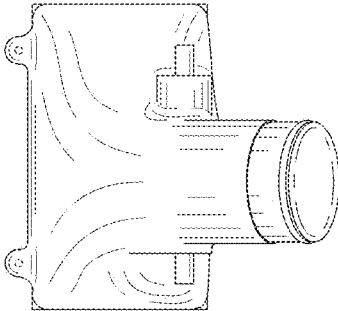

FIG. 4

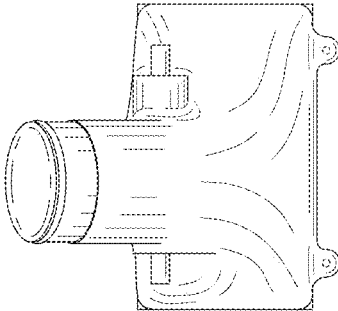

FIG. 5

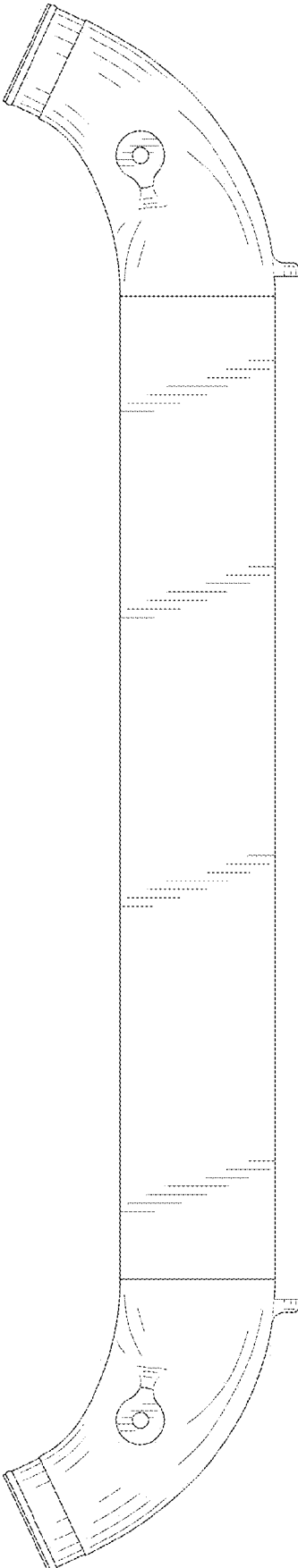

FIG. 6

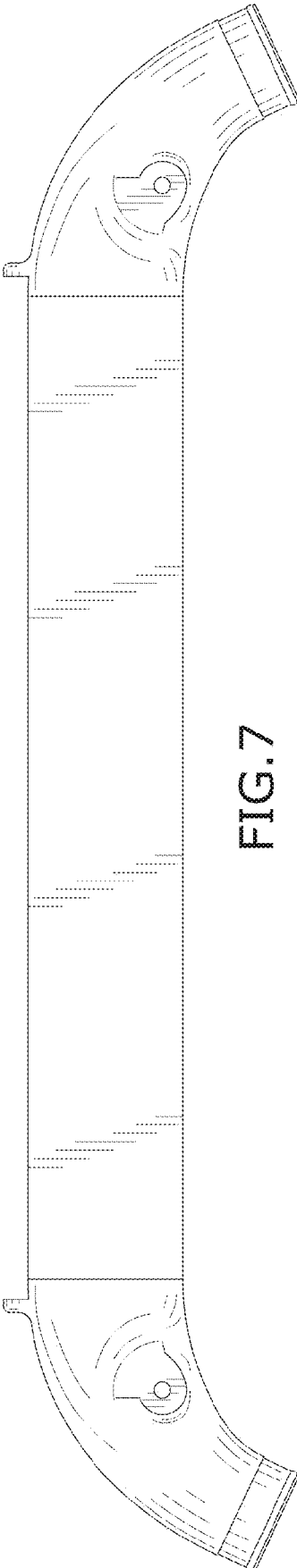

FIG. 7