

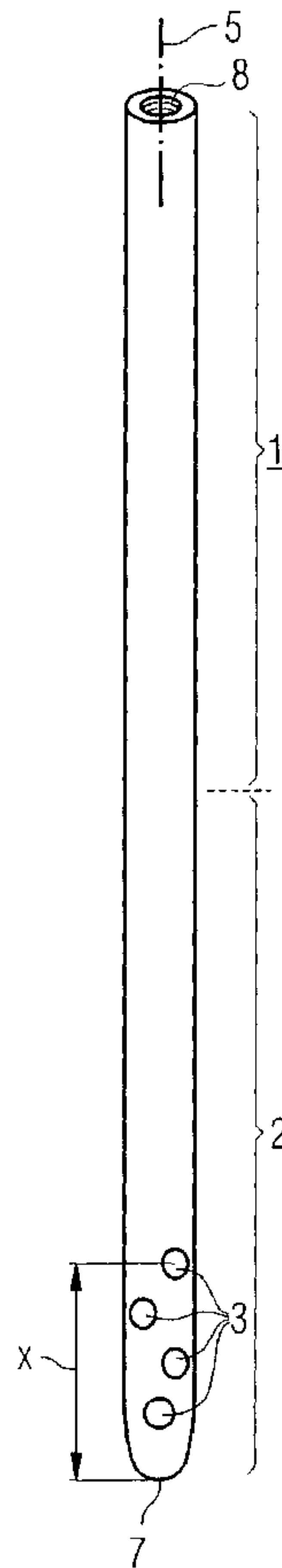

(86) Date de dépôt PCT/PCT Filing Date: 2002/09/27
 (87) Date publication PCT/PCT Publication Date: 2004/04/08
 (85) Entrée phase nationale/National Entry: 2005/03/24
 (86) N° demande PCT/PCT Application No.: CH 2002/000538
 (87) N° publication PCT/PCT Publication No.: 2004/028383

(51) Cl.Int.⁷/Int.Cl.⁷ A61B 17/72
 (71) Demandeur/Applicant:
 SYNTHES (U.S.A.), US
 (72) Inventeur/Inventor:
 MARTIN, DANIEL, US
 (74) Agent: OSLER, HOSKIN & HARCOURT LLP

(54) Titre : CLOU CENTROMEDULLAIRE
 (54) Title: INTRAMEDULLARY NAIL



(57) Abrégé/Abstract:

The intramedullary nail has a longitudinal axis (5), a near end (1) with means (8) for coupling to an insertion device and a far end (2) with a tip (7) for insertion into the intramedullary canal of a long bone. The far end (2) is provided with at least two traversing

(57) **Abrégé(suite)/Abstract(continued):**

through holes (3) with axes (6), all of said through holes (3) being grouped in said far end (2) within a distance x measured from said tip (7) to the axis (6) of the most distant hole (3). The nail is provided with at least a third through hole (3) with axis (6) in said far end (2) which contains the first and second holes (3) and the projection of the hole axis (6) of said through holes (3) in a plane orthogonal to said longitudinal axis (5) is such that at least two of said projected hole axis (6) are at an angle α greater than zero and less than 90° with respect to each other.

(12) INTERNATIONAL APPLICATION PUBLISHED UNDER THE PATENT COOPERATION TREATY (PCT)

(19) World Intellectual Property
Organization
International Bureau



(43) International Publication Date
8 April 2004 (08.04.2004)

PCT

(10) International Publication Number
WO 2004/028383 A1

- (51) International Patent Classification⁷: **A61B 17/72**
- (21) International Application Number: PCT/CH2002/000538
- (22) International Filing Date: 27 September 2002 (27.09.2002)
- (25) Filing Language: English
- (26) Publication Language: English
- (71) Applicant (for all designated States except CA, US): **SYNTHES AG CHUR** [CH/CH]; Grabenstrasse 8, CH-7002 Chur (CH).
- (71) Applicant (for CA only): **SYNTHES (U.S.A)** [US/US]; 1690 Russell Road, P.O. Box 1766, Paoli, PA 19301-1222 (US).
- (72) Inventor; and
- (75) Inventor/Applicant (for US only): **MARTIN, Daniel** [US/US]; 1157 Harker Avenue, Palo Alto, CA 94301 (US).
- (74) Agent: **LUSUARDI, Werther**; Dr. Lusuardi AG, Kreuzbühlstrasse 8, CH-8008 Zürich (CH).
- (81) Designated States (national): AE, AG, AL, AM, AT, AU, AZ, BA, BB, BG, BR, BY, BZ, CA, CH, CN, CO, CR, CU, CZ, DE, DK, DM, DZ, EC, EE, ES, FI, GB, GD, GE, GH, GM, HR, HU, ID, IL, IN, IS, JP, KE, KG, KP, KR, KZ, LC, LK, LR, LS, LT, LU, LV, MA, MD, MG, MK, MN, MW, MX, MZ, NO, NZ, PL, PT, RO, RU, SD, SE, SG, SI, SK, SL, TJ, TM, TR, TT, TZ, UA, UG, US, UZ, VN, YU, ZA, ZW.
- (84) Designated States (regional): ARIPO patent (GH, GM, KE, LS, MW, MZ, SD, SL, SZ, TZ, UG, ZM, ZW), Eurasian patent (AM, AZ, BY, KG, KZ, MD, RU, TJ, TM), European patent (AT, BE, BG, CH, CY, CZ, DE, DK, EE, ES, FI, FR, GB, GR, IE, IT, LU, MC, NL, PT, SE, SK,

[Continued on next page]

(54) Title: INTRAMEDULLARY NAIL

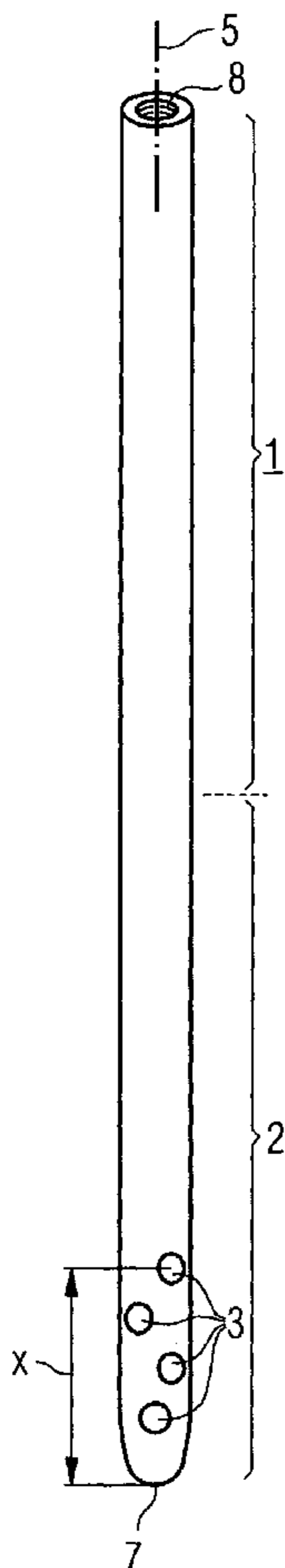

(57) Abstract: The intramedullary nail has a longitudinal axis (5), a near end (1) with means (8) for coupling to an insertion device and a far end (2) with a tip (7) for insertion into the intramedullary canal of a long bone. The far end (2) is provided with at least two traversing through holes (3) with axes (6), all of said through holes (3) being grouped in said far end (2) within a distance x measured from said tip (7) to the axis (6) of the most distant hole (3). The nail is provided with at least a third through hole (3) with axis (6) in said far end (2) which contains the first and second holes (3) and the projection of the hole axis (6) of said through holes (3) in a plane orthogonal to said longitudinal axis (5) is such that at least two of said projected hole axis (6) are at an angle α greater than zero and less than 90° with respect to each other.

WO 2004/028383 A1

WO 2004/028383 A1



TR), OAPI patent (BF, BJ, CF, CG, CI, CM, GA, GN, GQ,
GW, ML, MR, NE, SN, TD, TG).

For two-letter codes and other abbreviations, refer to the "Guidance Notes on Codes and Abbreviations" appearing at the beginning of each regular issue of the PCT Gazette.

Published:

— *with international search report*

Intramedullary nail

This invention concerns an intramedullary nail in accordance with the pre-characterising portion of Claim 1.

Such a nail is known from the DE-C-3 244 243 ENDER which discloses a rigid intramedullary nail having two through holes at the distal end of the nail and whose direction is not parallel and not orthogonal and which is further defined in the specification to be at an acute angle, e.g. of 10° or 60° .

A further nail is known from US 5.041.115 FRIGG ET AL. which discloses an intramedullary nail having three through holes at the distal end of the nail which are disposed at 90° to each other.

A disadvantage of the known nails is the fact that the distal holes are unnecessarily far from the distal nail tip which produces a nail-weakening effect, and prevents engagement in very short far fragments.

A further disadvantage of the known nails having parallel holes spaced closely to one another (i.e. known nails hole spacings equal to 3,5(d) is the fact that holes in the bone surface are too close to one another.

Still a further disadvantage is that widely spaced parallel or orthogonal holes offer the surgeon limited options in the choice of the position of the screws, such as might be necessary to avoid neurovascular structures.

A further disadvantage of these known nails is the fact that there is an unnecessary loose fit to the hole in the nail by the screws which traverse the nail. This allows a toggling of the traversing screw in the hole, in turn allowing an increased torsional and other motion at the fracture site.

The invention as claimed aims at solving the above described problems/disadvantages and also in order to facilitate secure attachment in short fragments at the far end of the intramedullary nail.

The present invention provides an intramedullary nail as defined in Claim 1.

Surprisingly, mechanical and clinical studies undertaken by the inventor, have revealed that of two different intramedullary nails having the same number of traversing holes clustered near the distal tip of the nail, the one with holes clustering closed to the tip of the nail is less likely to face failure through a screw hole than the intramedullary nail with greater hole spacing. Furthermore unused holes between the nail tip and x-position do not weaken the nail more than does the x-position hole. This is true for the same diameter.

The x-position hole is the hole in the far half of the intramedullary nail which is farthest from the tip of the nail.

The multiple hole/close spacing intramedullary nail according to the invention can be used for all known applications, i.e. proximal fracture, extreme distal fracture, ankle fusion and correction of deformity and therefore replaces all known nails with one single type, making storage much simpler and less costly. It maximises the number of screws which can be placed near the tip of the nail, increasing the surface contact area between the hardware and the bone.

The invention offers the following advantages:

- 1) it prevents adjacent screws from having their bone cortex holes too close to one another; thereby reducing crack propagation between these bone cortex holes.
- 2) it gives the surgeon different anatomical position options for placement of screws to provide more secure bony fixation or to allow avoidance of neurovascular structures.
- 3) it controls angular motion of the fragment with respect to the intramedullary nail by way of a greater possible number of screws, screws in multiple directions, and closer fit of the screws in the holes.

In a preferred embodiment of the intramedullary nail the distance x measured from the tip of the nail to the axis of the hole most distant from the tip is equal or smaller than $25d$, preferably equal or smaller than $7d$, d being the diameter of the holes.

In a preferred embodiment of the invention the projected hole axes of at least two of said through holes are at an angle α of approx. 30° , 36° , 45° or 60° or multiples thereof.

Preferably a number of $n \geq 4$ holes are grouped in the far end of the nail within a distance x which is smaller than $2(n)(d)$, d being the diameter of the holes. More preferably the value for x is smaller than $1,5(n)(d)$.

In a preferred embodiment the value of n for the number of holes is 5 or 6.

At least two through holes may be located in such a way that the geometric hollow cylinders, as defined by these holes, intersect with one another, preferably with intersecting axes of these cylinders. The two intersecting through holes may be located at the same distance d from said tip of the nail and preferably are spaced $88^\circ - 92^\circ$ apart. In the above specified formulae for the distance x the two holes which intersect, only one should be included in the number n of holes.

In order to facilitate a more secure fixation with the interlocking screw having an outer thread at least one of the through holes may be provided with a matching internal thread. This facilitates more secure fixation with the interlocking screw having a matching outer thread.

Furthermore a portion of one or more screw holes may be substantially conical in geometry.

The intramedullary nail has preferably a solid cross-section, but may have alternatively a tubular cross-section.

Preferably all holes are located in planes orthogonal to the longitudinal axis of the nail.

The distance (a) between the tip of the nail and that through hole which nearest to the tip (7) may be $(a) \leq 5 d$, and preferably $(a) \leq 1,5 d$, whereby d is the diameter of the through hole.

In a preferred embodiment a plurality of n through holes are provided in the nail whose centres are located at a distance x from said tip which is comprised in the range of

$$1,05 (n) (d) \leq x \leq 3,00 (n) (d)$$

In a further preferred embodiment a plurality of n through holes are provided in the nail whose centres are located at a distance x from the tip which is smaller than $4 d + (n-1) (2,2 d)$.

Preferably the distance "b" between the axes of two adjacent through holes is $b \leq 1,5 d$.

The intramedullary nail according to the invention may comprise an interlocking screw which has a diameter equal or larger than 0,9 times the hole diameter into which it is inserted; preferably the diameter is equal or larger than 0,94, most preferably 0,96 times the hole diameter into which it is inserted.

In the drawings:

Fig. 1 is a side view of the intramedullary nail according to the invention;

Fig. 2 is an enlarged detailed view of the far end of intramedullary nail of Fig. 1;

Fig. 3 is an enlarged detailed view of the far end of intramedullary nail showing the core where holes intersect;

Fig. 4 is the same view of Fig. 3 rotated by 90°;

Fig. 5 is section along the line V-V of Fig. 3; and

Fig. 6 is a representation of a plane orthogonal to the longitudinal axis of the nail with projections of the axis of the through holes showing the various angles at which the through holes traverse the nail.

Figure 1 shows an intramedullary nail with a solid cross-section having a longitudinal axis 5. The longitudinal axis 5 may be curved along a portion of the nail if the nail itself is curved in that portion. The intramedullary nail further comprises a near end 1 with means 8 consisting of an internally threaded bore for coupling to an insertion device and a far end 2 with a tip 7 for insertion into the intramedullary canal of a long bone. The far end 2 is provided with four traversing through holes 3 with axes 6, all of said through holes 3 being grouped in said far end 2 within a distance x measured from said tip 7 to the axis 6 of the most distant hole 3 (as indicated by the arrow in Fig. 1).

The projection of the hole axis 6 of said through holes 3 in a plane orthogonal to said longitudinal axis 5 (or if the hole axis 6 - as shown in the figures - is lying already in an orthogonal plane, the hole axis itself) is such that at least two of said (projected) hole axes 6 are at an angle α greater than zero and less than 90° with respect to each other. In Fig. 2 the angle α is approximately 60° .

In the nail according to Figs. 1 and 2 a number n of four holes 3 is grouped in said far end 2 within a distance x which is smaller than the product of $2(n)(d)$, d being the diameter of said holes 3.

In Figs. 3 to 5 an embodiment is shown in which two of said through holes 3 are located in such a way that the geometric hollow cylinders, as defined by said holes 3, intersect with one another. In particular the two intersecting through holes 3 have intersecting axes 6 and are located at the same distance "a" from the tip 7. The two holes 3 are located in an orthogonal plane to said longitudinal axis 5 and are spaced at an angle α 90° apart.

Fig. 6 shows a representation of a plane orthogonal to the longitudinal axis 5 of the nail 1 with projections of the axis 6 of the through holes 3 showing the various angles α_1 , α_2 , and α_3 in orthogonal projection at which the through holes 3 traverse the nail 1. The angles α_1 , α_2 , and α_3 may be in the range of 30° to 60° according to the anatomy requirements.

Claims

1. Intramedullary nail with a longitudinal axis (5), a near end (1) with means (8) for coupling to an insertion device and a far end (2) with a tip (7) for insertion into the intramedullary canal of a long bone, said far end (2) being provided with at least two traversing through holes (3) with axes (6), all of said through holes (3) being grouped in said far end (2) within a distance x measured from said tip (7) to the axis (6) of the most distant hole (3); and

characterized in that,

A) said nail is provided with at least a third through hole (3) with axis (6) in said far end (2) which contains the first and second holes (3); and

B) the projection of the hole axis (6) of said through holes (3) in a plane orthogonal to said longitudinal axis (5) is such that at least two of said projected hole axes (6) are at an angle α greater than zero and less than 90° with respect to each other.

2. Intramedullary nail according to claim 1, characterized in that said distance x is equal or smaller than $25d$, preferably equal or smaller than $7d$, d being the diameter of the largest of said holes (3).

3. Intramedullary nail according to claim 1, characterized in that said distance x is equal or smaller than $25d$, preferably equal or smaller than $7d$, d being the mean diameter of said holes (3).

4. Intramedullary nail according to one of the claims 1 - 3, characterized in that at least two of said projected hole axes (6) are at an angle α of $58^\circ \leq \alpha \leq 62^\circ$, preferably of $59^\circ \leq \alpha \leq 61^\circ$.
5. Intramedullary nail according to one of the claims 1 - 3, characterized in that at least two of said projected hole axes (6) are at an angle α of $43^\circ \leq \alpha \leq 47^\circ$, preferably of $44^\circ \leq \alpha \leq 46^\circ$.
6. Intramedullary nail according to one of the claims 1 - 3, characterized in that at least two of said projected hole axes (6) are at an angle α of $35^\circ \leq \alpha \leq 37^\circ$, preferably of $35,5^\circ \leq \alpha \leq 36,5^\circ$.
7. Intramedullary nail according to one of the claims 1 - 3, characterized in that at least two of said projected hole axes (6) are at an angle α of $29^\circ \leq \alpha \leq 31^\circ$, preferably of $29,5^\circ \leq \alpha \leq 30,5^\circ$.
8. Intramedullary nail according to one of the claims 1 to 7, characterized in that a number of $n \geq 4$ holes (3) are grouped in said far end (2) within said distance x .

9. Intramedullary nail according to one of the claims 1 to 8, characterized in that said distance x is smaller than $2(n)(d)$, preferably smaller than $1,8(n)(d)$, d being the diameter of the largest of said holes (3).

10. Intramedullary nail according to claim 9, characterized in that the value for x is smaller than $1,5(n)(d)$, preferably smaller than $1,4(n)(d)$.

11. Intramedullary nail according to one of the claims 1 to 9, characterized in that said distance x is smaller than $2(n)(d)$, preferably smaller than $1,8(n)(d)$, d being the mean diameter of said holes (3).

12. Intramedullary nail according to claim 11, characterized in that the value for x is smaller than $1,5(n)(d)$, preferably smaller than $1,4(n)(d)$.

13. Intramedullary nail according to one of the claims 1 to 12, characterized in that the value of n is 5.

14. Intramedullary nail according to one of the claims 1 to 12, characterized in that the value of n is 6.

15. Intramedullary nail according to one of the claims 1 to 14, characterized in that at least two of said through holes (3) are located in such a way that the geometric hollow cylinders, as defined by said holes (3), intersect with one another.

16. Intramedullary nail according to claim 15, characterized in that said two intersecting through holes (3) have intersecting axes (6).

17. Intramedullary nail according to claim 16, characterized in that said two intersecting through holes (3) are spaced at an angle α of $88^\circ - 92^\circ$.

18. Intramedullary nail according to one of the claims 1 to 17, characterized in that at least one of said through holes (3) is provided with an internal thread.

19. Intramedullary nail according to one of the claims 1 to 18, characterized in that at least part of at least one of said through holes (3) is conical.

20. Intramedullary nail according to one of the claims 15 to 19, characterized in that said two intersecting through holes (3) are located at the same distance (a) from said tip (7).

21. Intramedullary nail according to one of the claims 15 and 20, characterized in that only one of said two holes (3) which intersect both are included in the number n of said holes (3).

22. Intramedullary nail according to one of the claims 1 to 21, characterized in that it has a solid cross-section.

23. Intramedullary nail according to one of the claims 1 to 21, characterized in that has a tubular cross-section.

24. Intramedullary nail according to one of the claims 1 to 23, characterized in that the axes of all holes (3) are located in planes orthogonal to said longitudinal axis (5).

25. Intramedullary nail according to one of the claims 1 to 24, characterized in that the distance (a) between the tip (7) and that through hole (3) which is nearest to said tip (7) is

$$a \leq 5 d$$

whereby d is the diameter of said through hole (3).

26. Intramedullary nail according to claim 25, characterized in that said distance a is $\leq 1,5 d$.

27. Intramedullary nail according to one of the claims 1 to 26, characterized in that a plurality of n through holes (3) are provided whose centres (4) are located at a distance x from said tip (7) which is comprised in the range of

$$1,05 (n) (d) \leq x \leq 3,0 (n) (d)$$

28. Intramedullary nail according to one of the claims 1 to 27, characterized in that a plurality of n through holes (3) are provided whose centres (4) are located at a distance x from said tip (7) which is smaller than $4d + (n-1)(2,2d)$.

29. Intramedullary nail according to one of the claims 1 to 28, characterized in that the distance b between the axes (6) of two adjacent through holes (3) is $b \leq 1.5d$.

30. Assembly with an intramedullary nail according to one of the claims 1 to 29, characterized in that at least two of said holes (3) have axis projections in the orthogonal plane, such that the axis projections are parallel to one another.

31. Assembly with an intramedullary nail according to one of the claims 1 to 30, characterized in that at least two of said holes (3) have axis projections in the orthogonal plane which are at right angles to each other in the orthogonal plane.

32. Assembly with an intramedullary nail according to one of the claims 1 to 31, characterized in that it comprises an interlocking screw which has a major diameter equal or larger than 0,9 times the hole diameter into which it is inserted.

33. Assembly with an intramedullary nail according to claim 32, characterized in that the interlocking screw has a major diameter equal or larger than 0,94, preferably 0,96 times the hole diameter into which it is inserted.

FIG 1

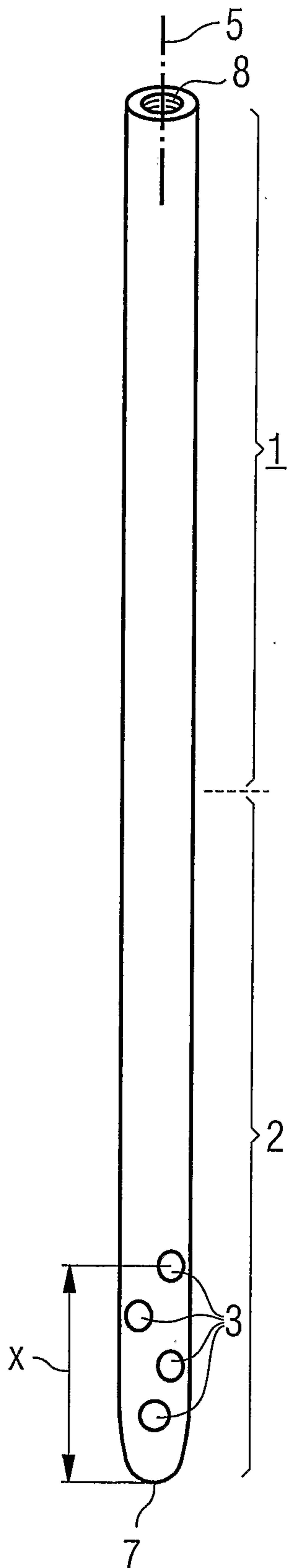
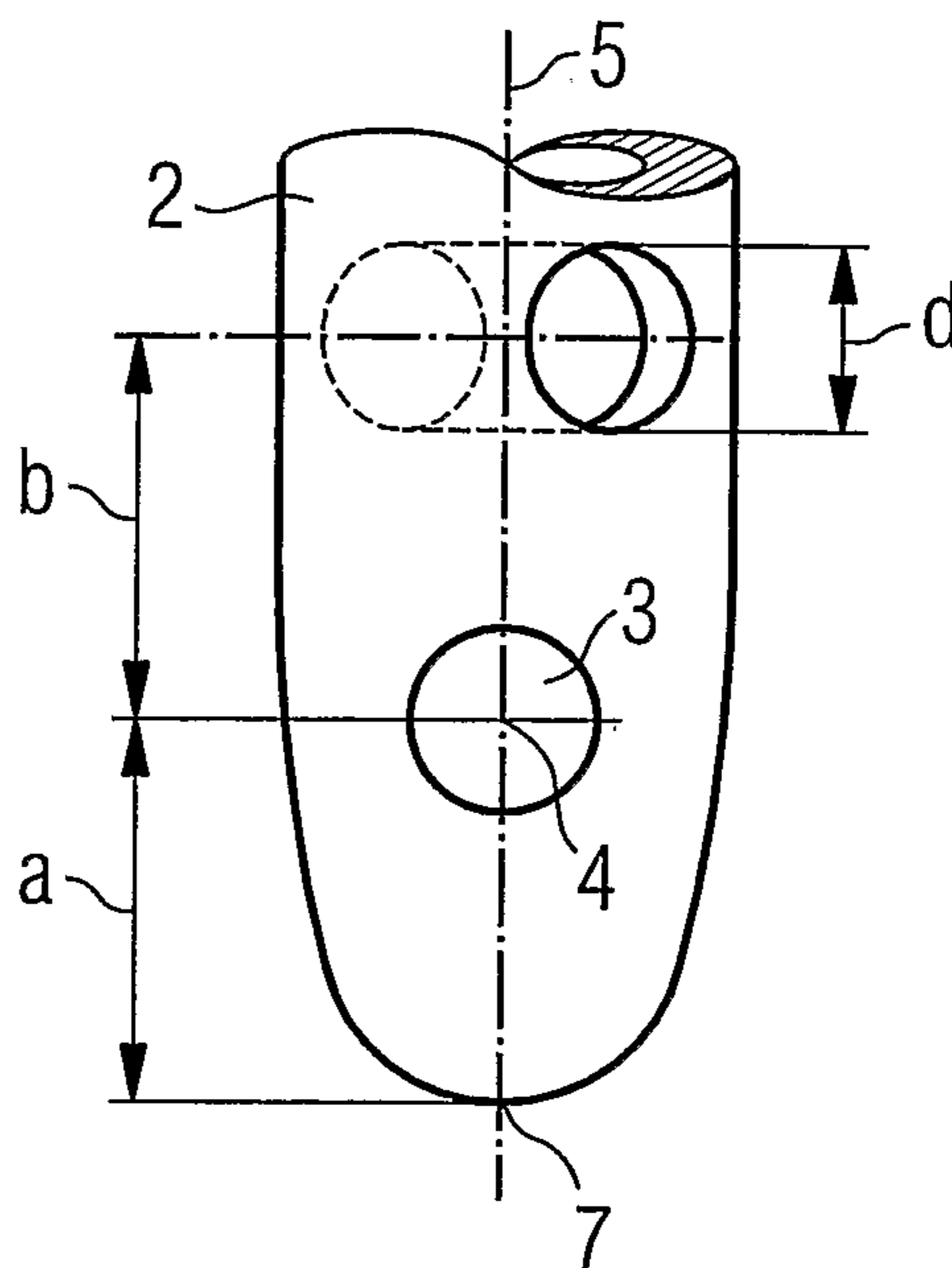

FIG 2



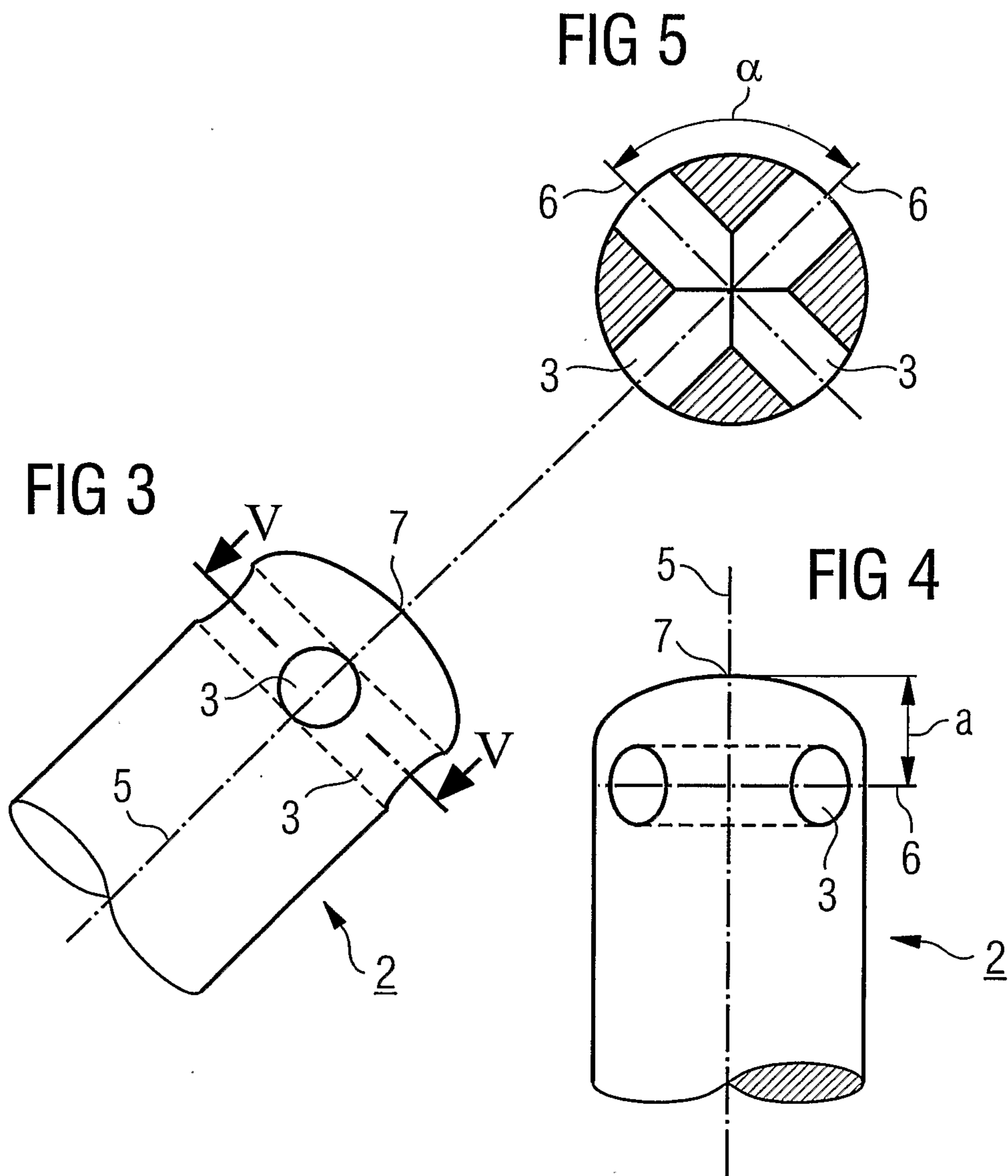
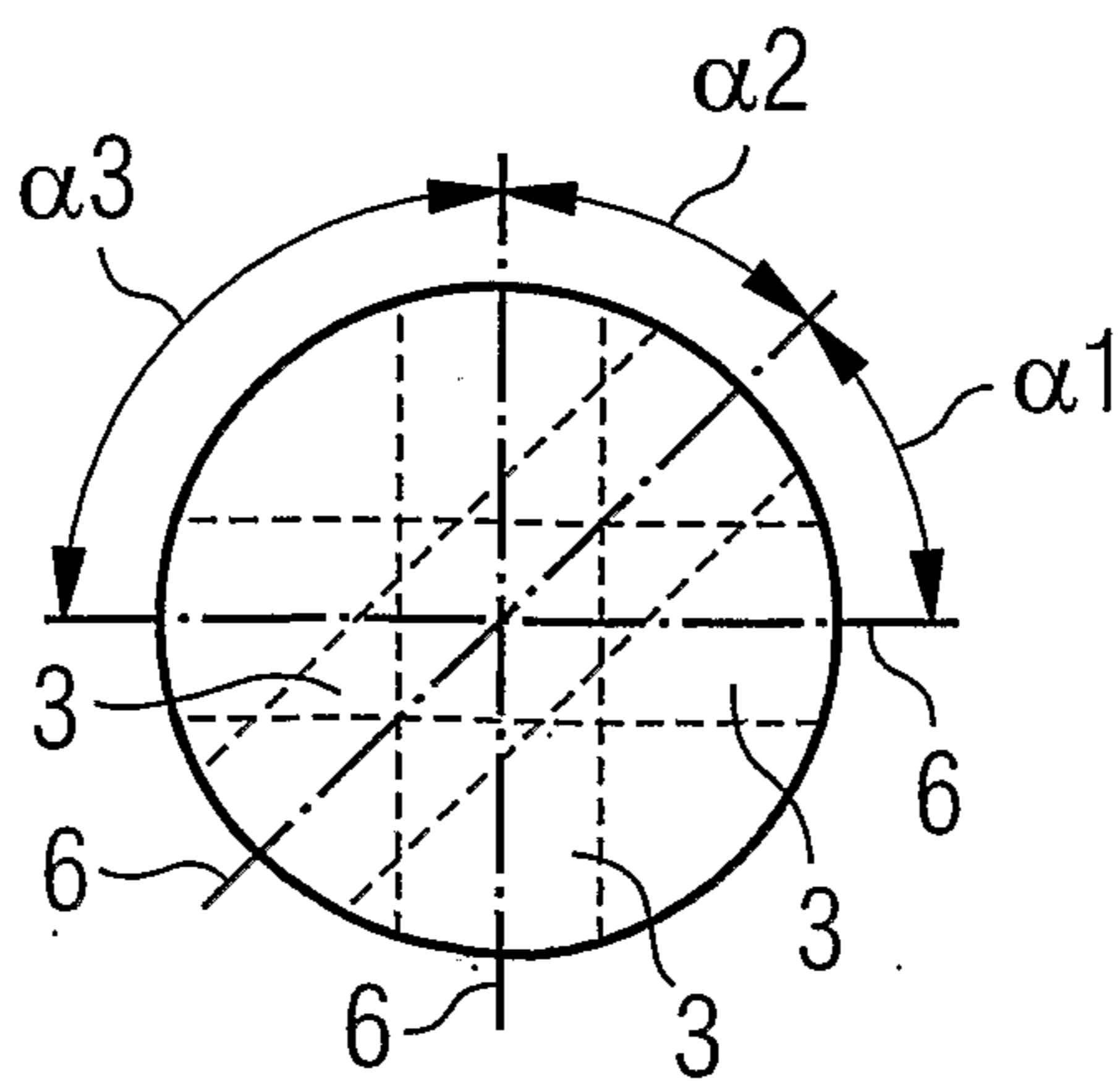

FIG 6



ERSATZBLATT (REGEL 26)

