



(86) Date de dépôt PCT/PCT Filing Date: 2008/04/07
 (87) Date publication PCT/PCT Publication Date: 2008/10/16
 (85) Entrée phase nationale/National Entry: 2009/10/06
 (86) N° demande PCT/PCT Application No.: US 2008/004478
 (87) N° publication PCT/PCT Publication No.: 2008/124112
 (30) Priorité/Priority: 2007/04/06 (US60/922,249)

(51) Cl.Int./Int.Cl. *A61F 2/00* (2006.01),
A61F 7/00 (2006.01)
 (71) Demandeurs/Applicants:
FLOCK, STEPHEN, US;
MARCHITTO, KEVIN, US
 (72) Inventeurs/Inventors:
FLOCK, STEPHEN, US;
MARCHITTO, KEVIN, US
 (74) Agent: BORDEN LADNER GERVAIS LLP

(54) Titre : CHAUFFAGE PAR INDUCTION DE TISSUS A L'AIDE DE CHAMPS MAGNETIQUES ALTERNATIFS ET SES APPLICATIONS

(54) Title: INDUCTIVE HEATING OF TISSUES USING ALTERNATING MAGNETIC FIELDS AND USES THEREOF

Fig 1

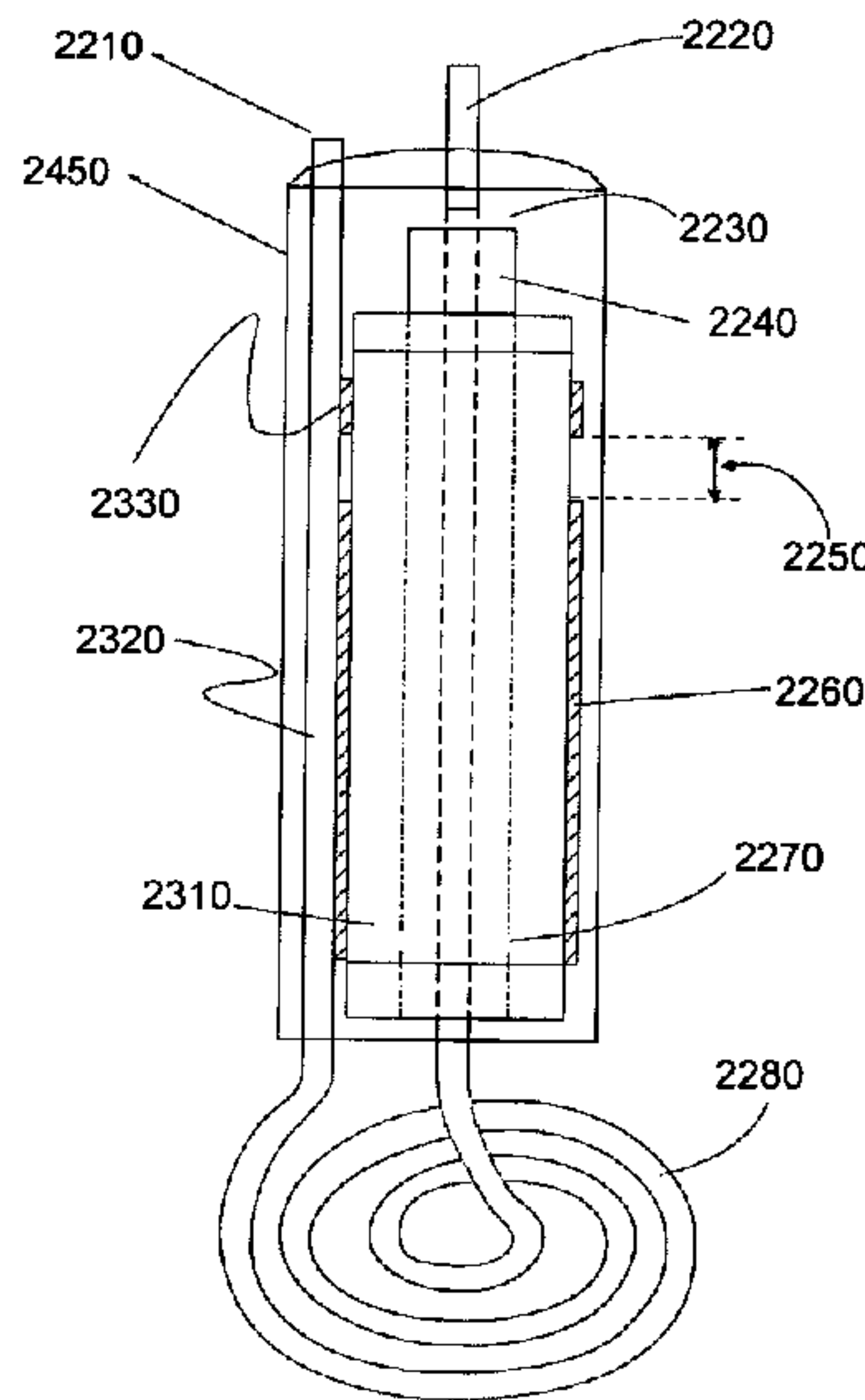

(57) **Abrégé/Abstract:**

With the present invention, it is possible to improve the cosmetic appearance of skin by controllably heating a superficial layer of skin thereby inducing acute tissue contraction or shrinkage and a wound response leading to the production of biomolecules, all of which result in improved cosmesis. The invention incorporates a source of radio frequency electrical energy coupled to coil, with requisite impedance matching network, thereby resulting in the production of an alternating magnetic field. When tissue is brought into proximity of the alternating magnetic field, inductive heating of the tissue results as a consequence of either or both of dipole formation and oscillation, and eddy current formation. Optionally, cooling is provided to remove heat from the coil, the source of radio frequency electrical energy, or the surface of the skin alone or in combination. The invention exhibits the significant benefits of, among other things, being non-invasive, not requiring electrical contact with the body of the subject, and providing controllable heating only to a thin layer of tissue. The invention is useful not only for cosmetic procedures such as facial rejuvenation, wrinkle treatment, acne treatment, hair removal, vascular lesion treatment, varicose vein treatment, curing of fillers, and treatment of cellulite, but also for surgical procedures such as coagulation, cauterization or for induction of biomolecular events such as a wound response, production of heat-shock proteins or an inflammatory response in tissue.

(12) INTERNATIONAL APPLICATION PUBLISHED UNDER THE PATENT COOPERATION TREATY (PCT)

(19) World Intellectual Property Organization
International Bureau(43) International Publication Date
16 October 2008 (16.10.2008)

PCT

(10) International Publication Number
WO 2008/124112 A1

(51) International Patent Classification:

A61F 2/00 (2006.01) A61F 7/00 (2006.01)

(21) International Application Number:

PCT/US2008/004478

(22) International Filing Date: 7 April 2008 (07.04.2008)

(25) Filing Language: English

(26) Publication Language: English

(30) Priority Data:

60/922,249 6 April 2007 (06.04.2007) US

(71) Applicant and

(72) Inventor: FLOCK, Stephen [US/US]; 13379 West 61st Street, Arvada, CO 80004 (US).

(72) Inventor; and

(75) Inventor/Applicant (for US only): MARCHITTO, Kevin [US/US]; 15403 West 51st Place, Golden, CO 80403 (US).

(74) Agent: ADLER, Benjamin, A.; Adler & Associated, 8011 Candle Lane, Houston, TX 77071 (US).

(81) Designated States (unless otherwise indicated, for every kind of national protection available): AE, AG, AL, AM,

AO, AT, AU, AZ, BA, BB, BG, BH, BR, BW, BY, BZ, CA, CH, CN, CO, CR, CU, CZ, DE, DK, DM, DO, DZ, EC, EE, EG, ES, FI, GB, GD, GE, GH, GM, GT, HN, HR, HU, ID, IL, IN, IS, JP, KE, KG, KM, KN, KP, KR, KZ, LA, LC, LK, LR, LS, LT, LU, LY, MA, MD, ME, MG, MK, MN, MW, MX, MY, MZ, NA, NG, NI, NO, NZ, OM, PG, PH, PL, PT, RO, RS, RU, SC, SD, SE, SG, SK, SL, SM, SV, SY, TJ, TM, TN, TR, TT, TZ, UA, UG, US, UZ, VC, VN, ZA, ZM, ZW.

(84) Designated States (unless otherwise indicated, for every kind of regional protection available): ARIPO (BW, GH, GM, KE, LS, MW, MZ, NA, SD, SL, SZ, TZ, UG, ZM, ZW), Eurasian (AM, AZ, BY, KG, KZ, MD, RU, TJ, TM), European (AT, BE, BG, CH, CY, CZ, DE, DK, EE, ES, FI, FR, GB, GR, HR, HU, IE, IS, IT, LT, LU, LV, MC, MT, NL, NO, PL, PT, RO, SE, SI, SK, TR), OAPI (BF, BJ, CF, CG, CI, CM, GA, GN, GQ, GW, ML, MR, NE, SN, TD, TG).

Published:

- with international search report
- before the expiration of the time limit for amending the claims and to be republished in the event of receipt of amendments

(54) Title: INDUCTIVE HEATING OF TISSUES USING ALTERNATING MAGNETIC FIELDS AND USES THEREOF

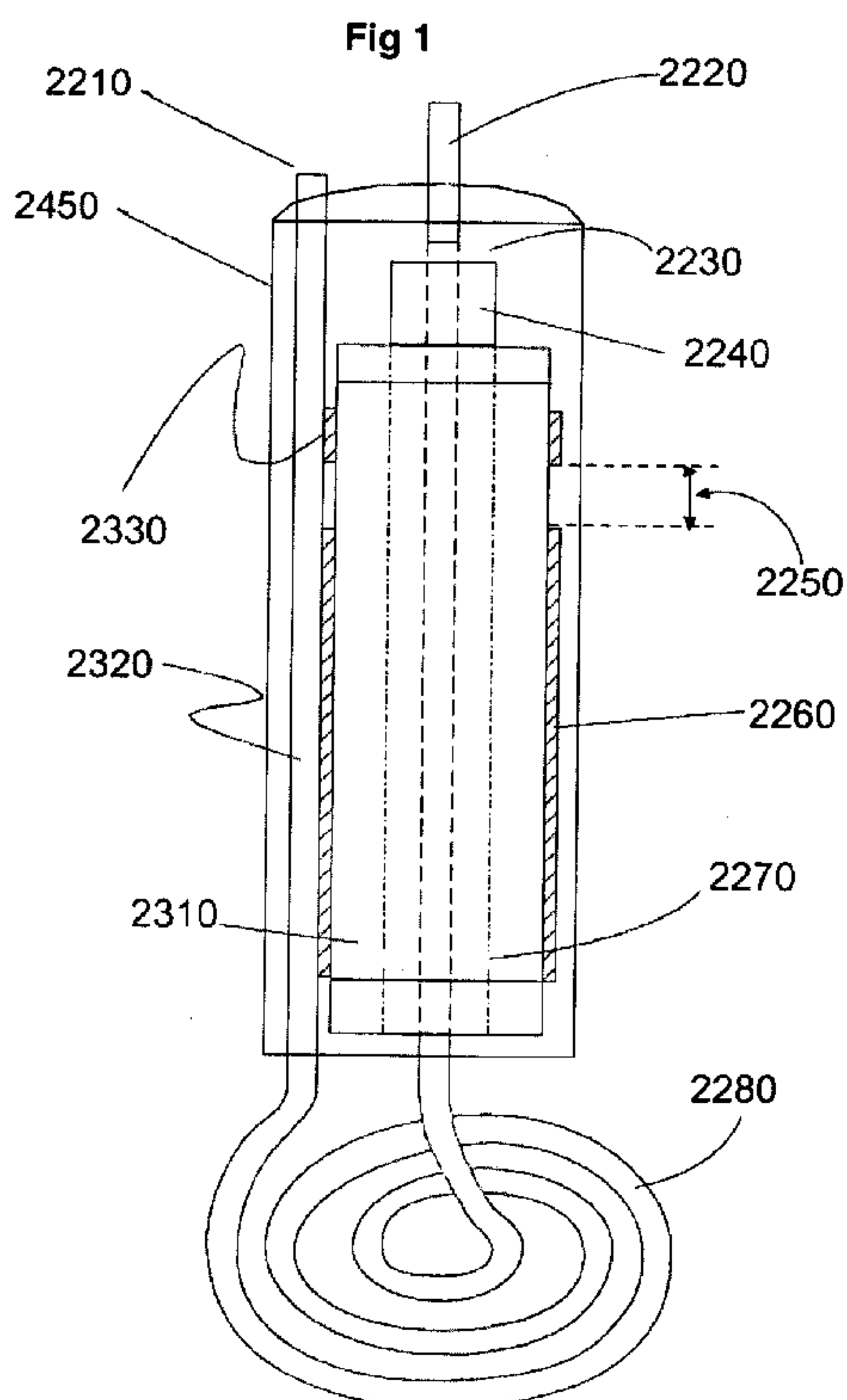

(57) Abstract: With the present invention, it is possible to improve the cosmetic appearance of skin by controllably heating a superficial layer of skin thereby inducing acute tissue contraction or shrinkage and a wound response leading to the production of biomolecules, all of which result in improved cosmesis. The invention incorporates a source of radio frequency electrical energy coupled to coil, with requisite impedance matching network, thereby resulting in the production of an alternating magnetic field. When tissue is brought into proximity of the alternating magnetic field, inductive heating of the tissue results as a consequence of either or both of dipole formation and oscillation, and eddy current formation. Optionally, cooling is provided to remove heat from the coil, the source of radio frequency electrical energy, or the surface of the skin alone or in combination. The invention exhibits the significant benefits of, among other things, being non-invasive, not requiring electrical contact with the body of the subject, and providing controllable heating only to a thin layer of tissue. The invention is useful not only for cosmetic procedures such as facial rejuvenation, wrinkle treatment, acne treatment, hair removal, vascular lesion treatment, varicose vein treatment, curing of fillers, and treatment of cellulite, but also for surgical procedures such as coagulation, cauterization or for induction of biomolecular events such as a wound response, production of heat-shock proteins or an inflammatory response in tissue.

 WO 2008/124112 A1

INDUCTIVE HEATING OF TISSUES USING ALTERNATING MAGNETIC FIELDS AND USES THEREOF

BACKGROUND OF THE INVENTION

Field of the invention

The present invention relates generally to the fields of biomedical engineering, biochemistry, medical treatment, and surgical procedures. More specifically, the present invention provides methods, devices, and compositions for inducing changes in tissues, biomolecules, and bioactive molecules. These changes are notably useful for inducing alterations in tissues, most notably in skin, for cosmetic purposes.

Description of the Related Art

Heating of tissue is a fundamental physical event in many different medical procedures. Depending on the time-temperature history of the tissue, a cascade of physical, chemical, and biological events occurs when tissue is heated. These events can lead to a beneficial or deleterious response. One example of a beneficial response is the reduction or elimination of the appearance of skin wrinkles as a result of heat induced tissue contraction.

Skin wrinkles

Skin wrinkles are often the consequence of advancing age and sun exposure. With increasing age and excessive sun exposure, skin quality deteriorates. This is due, in part, to changes in hydration and epidermal thickness, and on a molecular scale, to a decrease in the amount of collagen in the dermis. Further, subcutaneous fat accumulates or atrophies leading to furrowing of the skin,

which produces wrinkles. In today's society, the appearance of skin wrinkles is often viewed negatively and so there is a desire in the community for a means to safely reduce or eliminate wrinkles.

Skin Rejuvenation

For many years, wrinkles have been treated with chemical peels or mechanical dermabrasion, cosmetic medical procedures in which the surface of the epidermis of the skin (the stratum corneum) is removed chemically or by abrasion (sanding), respectively. In the late 1980s, laser ablation procedures for skin resurfacing were developed and approved. Today they remain in use, but are being replaced by laser procedures that are non-ablative and less damaging to surrounding tissues. The goal of these procedures includes tissue contraction, or skin-tightening, as well as induction of a wound response that leads to the generation of new collagen, and hence, dermal thickening. In the mid to late 1990s, another cosmetic technique for skin was developed that involves a non-ablative thermal alteration to skin. This procedure, referred to as radiofrequency (RF) skin rejuvenation, is mediated through capacitive-coupling of radiofrequency energy (e.g. U.S. Patent No. 7,189,230), using modified electrosurgical devices.

Radiofrequency rejuvenation can result in tissue contraction as tissue structural proteins and proteoglycans thermally denature and coagulate. A second effect of this procedure is a beneficial wound response causing the production of new collagen. More recently, additional devices for skin rejuvenation have been developed that employ ultrasound, high-temperature plasma directed at the tissue, or radiofrequency electromagnetic fields.

All of the current technology can result in deleterious effects in patients and create problems for the operators. For example, laser radiant energy is potentially hazardous to the operator and precautions must be made to safely contain it, and patients often report burns resulting from laser treatments.

Most radiofrequency devices work through capacitive-coupling whereby potentially hazardous electrical current passes through the patient's body, resulting in the creation of radiofrequency electric fields at the interfaces of tissues

that are weak- or non-polarity. This effect capacitive coupling can lead to burns at electrodes, and inadvertent heating of collateral tissues, such as adipose tissue. This heating of collateral tissues is an undesirable consequence for skin rejuvenation that can result in atrophy, particularly in fat layers in skin during cosmetic treatments. Further, generation of smoke and charring of tissue is a common consequence of the use of electrosurgical devices. For example, during surgery, an "inadvertent capacitor" can be created between a laparoscope and the electrosurgical probe, resulting in the creation of electrical currents where they are not expected.

The instant invention eliminates the risk of charring and the generation of smoke, as it does not rely on capacitive coupling for its effects. The patient is isolated from the electrical current in the devices and no electrical current is conducted from the applicator or the patient. The invention preferably is used for the direct heating of moist conductive tissues, such as the viable dermis during cosmetic skin treatment, and less efficiently for tissues of low hydration (e.g. stratum corneum), or of low polarity (adipose), thereby providing a safer means for treating skin.

Skin Cooling

When viable tissues reach temperatures of 55C to 60C, tissue necrosis may occur. This is one concern during laser and radiofrequency cosmetic skin treatments. Thus, various methods of skin cooling are often employed (Anderson, RR, 2003), including the spraying of cryogen on the skin surface or on an applicator, or applying cold air, water or ice to the skin. One prior art method for the purpose of skin cooling is the application of ice cubes to the skin surface prior to laser treatment, (Gilcrest et al., 1982). These treatments have not proven entirely satisfactory, nor more importantly led to an improved therapeutic response, that is improved blanching of the port wine stain, (nevus flammeus), which is a vascular birthmark consisting of superficial and deep dilated capillaries in the skin that produce a reddish to purplish discoloration of the skin.

Other prior art attempts to provide surface cooling of the epidermis using plastic bags filled with ice placed on the skin surface for five minutes,

compressed freon gas used during irradiation, or chilled water spread directly on the area being irradiated have also been explored, (Welch et al., 1983). However, these studies were done with pig cadaver tissue and normally utilized cooling periods of 2 to 14 seconds. The reported results with freon were good in only 28.5 percent of the cases, in some cases, the skin surface was momentarily frozen, and in others, the freon jet was found to overcool the skin surface.

Thus, the prior art is deficient in methods and devices for non-invasive and safer methods of skin rejuvenation induced by high frequency alternating magnetic fields that inductively heat skin tissues. The prior art is also deficient in the use of alternating magnetic fields to inductively heat conductive dermal tissues with a high degree of specificity. The prior art is also deficient in methods and devices to target during the skin rejuvenation process only conductive dermal tissue and have little effect on fat and skin surface tissues. The present invention fulfills this longstanding need and desire in the art.

SUMMARY OF THE INVENTION

The present invention is directed to a method of treatment of tissues in a subject, most notably for cosmetic treatment of skin. The method involves creating a high-frequency alternating magnetic field that, when directed in proximity with tissue, results in the production of heat through inductive coupling with the tissue thus resulting in the desired biologic effect. Representative examples of such biologic effects include, but are not limited to coagulation, cauterization, tissue contraction or shrinkage, and induction of a wound response that leads to biomolecular changes such as the production of collagen by cells.

The present invention also is directed to methods to coagulate tissue. The coagulation process may be beneficial in ablating tissue, fusing tissue, and in improving skin cosmesis.

The present invention is directed further still to a method of monitoring the treatment process in tissue. The heating process may be controlled by feedback monitoring and adjustment of the heating process in accord to the results. Methods

of monitoring include, but are not limited to, detection heat generation, monitoring eddy current formation in the tissue, ultrasound detection of tissue alterations or changes in impedance in tissues that lead to an impedance mis-match between the magnetic field applicator and the radiofrequency generator.

The present invention is yet directed further still to a method of cooling the surface of the skin during a treatment with. The cooling method of the present invention preferably involves cooling of a thermally conductive surface in contact with the skin. This may be accomplished by circulating coolant through the component in contact with the surface of the skin, or the contact component may be cooled by circulating coolant through the device coil component, or by directing cryogenic liquid or gas on the surface of the skin, to the contact surface, or the device coil component, before, during or after treatment.

The present invention is directed further still to a method of inducing a beneficial wound response in tissue by exposing the tissue to a high-frequency alternating magnetic field that induces the movement of charged species within the tissue leading to various biologic responses, some of which are induced by the concomitant production of heat in the tissue. One beneficial would response is the production of new collagen in the skin and dermal thickening.

The present invention is yet directed further still to a device for altering tissue incorporating a source of electromagnetic energy, a cooling system, an induction coil, an impedance matching network, and optionally, a means of controlling the process.

The present invention is directed further to a device for treating tissue incorporating a hand piece coupled to the energy output of a radiofrequency generator, whereby the hand piece incorporates an impedance matching network, a cooling system, and optionally a feedback mechanism to ensure proper treatment of the tissue. Optionally, a mechanical or pneumatic tissue-shaper, which can manipulate the tissue into a beneficial position and shape proximal to the hand piece is incorporated.

The present invention is yet directed further still to a device for altering tissue incorporating a source of electromagnetic energy, an induction coil, a cooling system, an impedance matching network, and a means of controlling the process

through feedback monitoring by detection of eddy currents, or detection of an additional source of radiant energy, plasma energy, acoustic energy, bipolar electrosurgical energy, or monopolar electrosurgical energy.

Other and further aspects, features, and advantages of the present invention will be apparent from the following description of the presently preferred embodiments of the invention given for the purpose of disclosure.

BRIEF DESCRIPTION OF THE DRAWINGS

So that the matter in which the above-recited features, advantages and objects of the invention, as well as others that will become clear, are attained and can be understood in detail, more particular descriptions of the invention briefly summarized above may be had by reference to certain embodiments thereof that are illustrated in the appended drawings. These drawings form a part of the specification. It is to be noted, however, that the appended drawings illustrate preferred embodiments of the invention and therefore are not to be considered limiting in their scope.

Figure 1 depicts an applicator that transduces radiofrequency electrical energy into a magnetic field.

Figure 2 depicts a hand piece incorporating a magnetic field applicator with optional cooling system.

Figure 3 depicts the endplate of the hand piece.

Figure 4 depicts a hand piece incorporating a solenoid-type inductor and positioning of tissue using pneumatic pressure.

Figure 5 depicts a circuit diagram of the applicator.

Figure 6 shows biopsied samples at each time point demonstrating a thickening of the dermis as compared to untreated controls.

Figure 7 shows biopsied samples at each time point demonstrating a production of neo-collagen in treated tissues as compared to the untreated controls.

Figure 8 shows a model of the expected mode of action produced by inductive heating on collagen within the treated tissues.

Figure 9 shows measurements taken at 27MHz and 600W. Bovine muscle, bovine fat, ovine skin, and human blood were used for comparison. The tissues were cut to 2x2x5 cm samples. Each sample was placed directly on the cap of the 27MHz device and imaged from above with a Raytek IR thermometer. The device was activated and the time to heat was recorded. (n=3 for each tissue type).

Figure 10 shows porcine fat, muscle and skin were used for comparison. The tissue samples were measured for thickness to ensure consistency between samples. The samples were between 1.5-2.0mm in thickness. The samples were placed on the faceplate which is 4mm thick PVC and imaged from above with a Raytek IR thermometer. The device was turned on and the time for the sample to reach 70°C was recorded. The IR thermometer is limited to recording the tissue surface opposite that which is in contact with the device. Therefore, it is believed that the actual temperature of the tissue was greater than indicated on the graph.

DETAILED DESCRIPTION OF THE INVENTION

One embodiment of the present invention provides a method of treatment for one or more tissue in an individual, comprising positioning an alternating magnetic field in proximity of the tissue, inducing heat therein, and thereby effecting treatment.

Radiofrequency Power Supply

The invention consists of a source of radiofrequency (RF) electrical energy, normally a radiofrequency generator such as sold by Comdel, Inc. (e.g. CV1000 or CV500, 40.68 MHz; Gloucester, MA). The electrical output of the generator is coupled to an applicator consisting of an inductor in the form of a coil (for the generation of a magnetic field), which is further part of an impedance matching network that may additionally comprise a capacitor. In some cases

applicator may include an antenna (for the production of an electrical field). The source of energy used may be a constant current or a constant voltage power supply or may be a modulated current or a modulated voltage power supply. The power-supply is able to produce radiofrequency energy with a power in the range 10-10,000 W and, depending on the application, may be more preferably in the range of about 100 to about 1000 W. The power-supply may typically operate at frequencies of 100 kHz to 2.4 GHz. Preferably the frequency range is about 100 kHz to about 5.8 GHz and, more preferably, the frequency range is at or near, or between 415 kHz to 4 MHz, 13.56 MHz, 27.12 MHz, 40.68, 67.8 MHz, 95 MHz, 433.92, 915 MHz, 2.4 GHz. The power-supply may optionally be one used in electrosurgery. Beneficially, the radiofrequency generator should be frequency-agile; that is, as the impedance of the load changes somewhat, the frequency output of the radiofrequency generator changes slightly to provide a better impedance match between the load and generator and so to maintain the output power within a controllable tolerance.

Applicator

Fig. 1 is a sectional view of an applicator used to produce a magnetic field. A center copper tube **2220**, which serves to conduct the radiofrequency electricity but also as an input for refrigerant, is surrounded by a TEFLON® cylinder **2240**. Endcaps **2230** and **2270** serve to position and hold the copper tube within the TEFLON® cylinder. The center copper tube **2220** is formed at the distal end of the applicator into a coil, **2280**, which then is fixed parallel **2320** with the center copper tube and directed to an exit **2210** out of the applicator; the coolant is directed out through exit **2210**. In order to provide impedance matching between the radiofrequency generator and applicator, a ceramic insulator **2310** is positioned around the TEFLON® cylinder **2240**. The ceramic insulator has two capacitor rings, **2330** and **2260**, made up of copper pipe. The pipe **2320** is in electrical contact with the capacitor rings. By adjusting the spacing **2250** between the two capacitor rings, the impedance match between the radiofrequency generator and applicator can be effected. The applicator is encased in a copper cylinder **2450** attached to the ground shield of the coaxial wire in order to shield any stray radiated radiofrequency.

Handpiece

Fig. 2 shows a view of one design for a hand piece **3300**, which is made of an electrically non-conductive material such as plastic, which surrounds the applicator. The main housing **3500** is optionally attached to a disposable shield **3350**, which serves to maintain cleanliness of the part of the handpiece which comes into contact with the skin **4300**. Optionally, the handpiece incorporates a coolant (for example, R-134a) contained in a housing **3520** and directed through a solenoid and pipe **3560** to an exit nozzle **3600**. This coolant can be controllably directed to the treated tissue before, during and/or after the treatment in order to limit the heating of the very superficial skin.

Cooling Endplate

Fig. 3 shows a view of an endplate **3550** on the distal end of the hand piece housing **3500**. The endplate is in intimate thermal contact with the coil **2280**, which has circulating refrigerant within, and so the endplate is cooled. This coolant may optionally be supplied from a circulating chiller utilizing water and antifreeze. Alternatively, gas such as air, nitrogen, freon, R-12, R-134a, and carbon dioxide could serve the purpose of cooling. Keeping in mind that the disposable shield **3350** is very thin and/or is highly thermally conductive, it serves to cool the skin before, during and/or after the treatment in order to limit the heating of the very superficial skin and increase comfort for the subject. Fig. 3 also shows an optional Faraday shield **3450**, which is a conductive element intended to reduce capacitive coupling of coil to the subject, and so to minimize any stray electric field. Note that the cooling endplate may be in intimate contact with the coil in order to provide optimal thermal conduction. This may be accomplished by molding or by forming the plate around the coil. As shown in Figure 2, cooling of the skin may be realized by spraying the skin with a coolant before, during or after treatment.

Pneumatic Applicator

Fig. 4 shows a partial view of an applicator incorporating a two-turn solenoid coil **4150**, the bore of which surround tissue **4260** which extrudes from the

skin 4300 up into the bore as a result of negative pneumatic pressure within the housing 3500. As the magnetic field within the turns of a solenoid is very much stronger than the field outside of a pancake coil, and the geometry of the tissue within the bore is different than illustrated in Fig. 2, the power required to obtain an effect is reduced and the effect on tissue can be more beneficial.

Combined Devices

In some aspects of this embodiment, the treatment may be inductive, or conductively or radiatively applied in combination with the use of an alternating magnetic field. Additionally, the energy may be pulsed in order to improve the thermal kinetics of the tissue heating. Examples of applied energy are radiofrequency energy, radiant energy, or vibrational energy. The radiofrequency energy may have a frequency from about 20 kHz to about 40 GHz, and may be applied using coils, electrodes or one or more antennae. The radiant energy may have a wavelength from about 600 nm to 11m. The vibrational energy may be sonic or ultrasonic with a frequency from about 20Hz to 80 MHz. In the case of inductive heating, the energy may not be incident on the target, but may be induced in the target to be converted from one form to another.

In certain aspects, combined devices, using induction plus an energy source (e.g. laser or ultrasound) may enhance the effects or be used to combine certain treatments. Because the interaction of laser energy and ultrasound waves with tissue is physically different than the present invention, it is anticipated that a different effect can be elicited. An applicator of radiant energy may consist of an optical assembly, which focuses the radiant energy on the relevant target or below the target surface, to get a sub-surface effect sparing the superior surface. A pressure-wave applicator may consist of a focused ultrasound transducer, which is coupled to the target tissue with an acoustic impedance matching material, such as gelatin, mineral oil or glycerin.

Feedback Monitoring and Safety Interlocks

In its preferred embodiment (Fig. 1), where a magnetic field is produced, the heating effect in tissue tends to change the electrical properties of the

tissue. As the tissue alters the electrical impedance that the radiofrequency generator sees, it is possible to use this change to monitor the heating process. For example, as the impedance of the skin changes, the impedance mismatch between the radiofrequency generator and the tissue/applicator increases and so the power reflected back into the radiofrequency generator increases. It is this increase in power that can be used as a signal to eventually halt the application of energy. Alternatively, the change in tissue can be detected using ultrasound or by detecting changes in eddy current formation.

As the tissue treatment process is initiated, the applicator (Fig 1) and most notably the coil **2280**, endplate (Fig. 3, **3550**), and tissue heat up; when the radiofrequency energy ceases, they cool down. Such temperature changes can easily be monitored by devices such as thermocouples or thermistors. As such devices can behave erratically in the presence of strong electromagnetic fields, devices such as infrared thermometers may be more suitable to monitor the temperatures.

Transducers monitoring the temperature and power output of the radiofrequency generator, the reflected power into the generator, the presence of water flow into the applicator (and generator, if it is required), and the presence of a short-circuit anywhere (indicted by a rapid rise in current in the generator and/or applicator, are an important safety feature in the present invention. Other optional safety interlocks include mechanical or electrical transducers between the disposable shield (Fig. 3, **3350**) and the housing of the hand piece; if a shield is not present, the RF generator would not engage. Encoding of the interlock in the shield would ensure that a particular shield is only used on a particular patient. Thermal switches are incorporated within the device to shut it down if overheating occurs. Fast breakers quickly cut off the output if a power-output transient occurs. Multiple interlocks are incorporated within the device, which prevents running the device with the cover removed. A foot pedal optionally is incorporated in order to minimize the possibility of unintentional activation of the device.

The induced magnetic field may also be actuated upon detection of a load. A relatively small current may be applied to the device while the device is not in proximity to a tissue target. As the device becomes proximal to the target, the

change in impedance is detectable, and this may be used as a signal to increase power to the device. This safety feature minimizes the exposure of the handpiece components to significant power load when the device is not applied to tissue, thus potentially reducing wear of the device.

Methods of Treatment

The device may be used to induce changes in tissue by applying alternating magnetic fields to the tissue such that currents are induced within the tissue (eddy currents). These currents encounter resistance and the result is the generation of heat. These eddy currents form most efficiently where there is a moist, polar environment, thus enabling electron displacement or ion flow within the target. Thus, for example, in skin, the generation of eddy currents in the moist underlying dermis is favored over the superficial dehydrated epidermis and stratum corneum layers, and the underlying, more non-polar adipose layer. This results in preferable heating of conductive tissues over non- or weakly-conductive tissues.

Variations in cooling of the skin surface may be achieved by increasing the volume of coolant to the device, or surface of the skin. These variations may be optimized to provide additional protection of the tissue proximal to the device from the effects of heating.

A scaffold or lattice structure may be placed within tissues to provide support. The structure may be fixed or fused in place using methods described herein. For example, localizing a scaffold made of polylactic acid, or a similar polymer in proximity to fat layers found in or under skin could prove beneficial in the treatment of cellulite fat. Cellulite produces an unattractive profile on the surface of skin due to the fat being squeezed between tissue structures resulting in upwelling of "fingers" of fat, which then distend the skin surface. Cellulite's cause is unclear, although it may result from fatty distension of the superficial fascia, which connects the dermis to the deep fascia. Attachment points to the dermis may be patent while surrounding areas lose structure and bulge, producing the "cobblestone" appearance on the surface of the skin. By increasing the number of attachment points, or by fixing a mesh-like substrate in place to minimize bulge, or by heating the fat to

achieve melting and flowing into the scaffold, cosmesis may conceivably be improved. The devices and methods described herein may be used to heat and melt fat layers.

Another embodiment of the present invention allows for treatment of acne, hair removal or treatment of varicose veins. It has been determined that the production of a critical amount of heat in tissue can lead to a cascade of events that results in a therapeutic effect. Acne can be treated by causing thermal damage in the affected skin, and hair removal can result from thermal damage to the hair follicles. The exact biologic mechanism behind these treatments is unclear, but tissue tightening may play a role. Alternatively, sublethal damage to the hair follicles can actually result in stimulating hair growth. Sublethal damage leads to a cascade of wound-response events such as the production of cytokines, interleukins and heat-shock proteins. These endogenous events can be beneficial and probably underly the salient events in, for example, stimulating hair-growth. In any case, the instant invention can induce all of these events.

Treatment of skin wrinkles can sometimes employ botulism toxin, whereupon an injection of toxin in or around the nerves associated with the wrinkle temporarily relax the muscle leading to reduction in the appearance of the wrinkle. Recently, electrosurgical ablation of the nerve has been shown to result in a good cosmetic effect and may benefit from being permanent. The problem with electrosurgical ablation of the nerves are the same as the problems associated with electrosurgical generators in other procedures. The present invention provides a means with which to ablate the nerve in a non-contact mode.

Coagulation is a very important technique in surgery as it provides a means to kill tissue without dissection, thus eliminating potentially toxic smoke and char, and by not removing tissue, allowing for mechanical integrity to be maintained for a period of time. Standard electrosurgical and electrocautery devices usually produce smoke when used to coagulate tissue (smoke is a potential source of carcinogens or viruses), and dry tissue tends to stick to the electrosurgical electrode which then results in re-bleeding when the electrode is removed from the treatment site. A non-contact way of coagulating tissue, using the instant invention, would be of paramount importance in surgery. The instant invention exhibits the benefit and

when the tissue is heated and dries, coupling between the magnetic field and tissue decreases thus limiting the heating and eliminating the possibility of smoke or charring.

As described below, the invention provides a number of therapeutic advantages and uses, but such advantages and uses are not limited by such description. Embodiments of the present invention are better illustrated with reference to the Figures 1-10, however, such reference is not meant to limit the present invention in any fashion. The embodiments and variations described in detail herein are to be interpreted by the appended claims and equivalents thereof.

The following examples are given for the purpose of illustrating various embodiments of the invention and are not meant to limit the present invention in any fashion.

EXAMPLE 1

Applicator

The pancake coil is made from 3.5 turns of 0.125" OD copper refrigeration tubing and has a diameter of 1.4". The coil must be hollow tubing to allow water or other cooling fluid to flow through it and dissipate the ~500W of heat generated. The main capacitor (Fig 1, 2260) has a value of ~70pF which resonates with the coil at 40.68MHz (Fig 5). Earlier prototypes were made with a TEFLON® dielectric ($\epsilon_r = 2.2$), but the size of the capacitor became too unwieldy to use in a handheld device. Capacitance can be calculated using the formula for a cylindrical capacitor: $C = (2 \cdot \pi \cdot \epsilon_r \cdot \epsilon_0) / (\ln(b/a))$, where, C = capacitance in pF per unit length, ϵ_r = dielectric constant (9.8), ϵ_0 = permittivity of free space = 8.85×10^{-12} f/m, b = outer diameter, a = inner diameter

The length of the capacitor is inversely proportional to the ϵ_r of the dielectric used, so alumina was chosen for its high ϵ_r and its other desirable properties: Good thermal conductivity – 30 W/m*K; High dielectric strength – 220 ACV/mil; High dielectric constant – 9.8; Available in tube form at low cost; Dimensions compatible with available copper pipe sizes. The particular alumina tube used is 3.5" long, 0.625" OD, 0.500" ID, 99.8% alumina (CoorsTek part #65677). The

inner and outer “plates” of the cylindrical capacitor are copper pipes that fit closely to the inner and outer diameters of the alumina tube.

It is critical that the copper tubes fit the alumina as closely as possible, as any air gaps will act as low value series capacitors and offset the advantage of the high er material. Since it is impossible to completely eliminate the air gaps, the entire capacitor assembly is potted in silicone with a er of 2.7 to regain some of the capacitance lost by the gaps, and also to help prevent the high voltage RF arcs which are bound to occur at these high voltages. The silicone, through vacuum encapsulation, completely surrounds all high voltage points on the device. The tuning capacitor (Fig 1, 2330), is formed in the same way as the main capacitor , although much smaller in value and size.

Shielding was found to be an important part of the design to reduce circuit detuning caused by the operator's hand, as well as reduce stray radiation from the connecting coax and radiofrequency generator. The shield encloses all the internal workings of the device, and is made from 1” copper pipe and an end cap. The shield also serves as a liquid tight container to hold the silicone (MOMENTIVE RTV615) during the vacuum encapsulation process.

Water-cooling is used to effectively cool both the coil and the coaxial capacitor assembly. Water flows in series through the center capacitor pipe, then the coil, and back through the copper tubing soldered to the outer capacitor pipe. At a power level of 500W and 0.75 liters/min flow, the water temperature rise is about 9°C.

A resonant circuit was the topology chosen to maximize the current in the coil because this type of circuit has the property that the circulating current is approximately Q times the applied current, and the Q of this circuit is about 60. The primary goals of the circuit are to maximize the current in the coil as well as provide a good impedance match to the 50 ohm RF generator driving it.

The alumina tube is cut to length using a wet cutting diamond saw. The inner pipe is then prepared by turning it down on a lathe to a size that just slides into the ceramic without forcing it. Copper disks and short lengths of 0.125” copper tubing

are soldered into the ends of the pipe, one going to the flexible silicone water tubing, and the other to the pancake coil.

A small batch of RTV615 is mixed up and de-aired in a vacuum chamber using a Welch 1400 vacuum pump. The mixture is considered de-aired after it foams up and then recedes (~30 minutes). About 1 ml of the RTV615 is poured into one end of the vertically held inner pipe/ceramic assembly and cured at 100 deg C for one hour, forming a silicone "plug" in that end to prevent the liquid RTV615 from running out during the next step. After cooling, the assembly is inverted and more RTV615 is poured into the other end and allowed to sink in and fill the gaps between the inner pipe and ceramic under vacuum. After sufficient time in the vacuum (no more rising air bubbles visible), the assembly is removed from the vacuum and again cured at 100 deg C for one hour.

Adhesive backed copper foil tape is tightly wrapped on the outer diameter of the ceramic assembly over a distance slightly shorter than the outer capacitor pipe. The purpose of the tape is to get a tight fitting conductor around the ceramic with minimal air gaps. The tape is mechanically weak and not thick enough to adequately conduct the heat generated, so copper pipe couplers are then bored out to slide over the layer of copper tape, and will be soldered in place once the initial tuning is completed. The "ring" pipe is bored out to tightly fit the ceramic at this time as well. About 0.4" of free ceramic is left on the end for high voltage insulation and spacing.

Next, the pancake coil is wound from the 0.125" refrigeration tubing, and the short end of the tubing from the center is coupled and soldered to the tubing stub on the capacitor assembly. The other (long/grounded) end of the tubing is positioned parallel and against the outer pipe (ground), and is temporarily held in place with copper tape for tuning.

A length of test coaxial cable from a network analyzer is temporarily soldered between ground and the ring. The outer pipe and ring are slid back and forth to obtain an impedance match at a frequency higher than the final operating frequency, knowing that the frequency will drop after encapsulation with silicone. Once the correct position is found, the grounded tubing of the pancake coil is soldered along the outer pipe and the gap between the copper foil and outer pipe is flooded with solder.

The silicone water tubing is now attached to the other stub of 0.125" tube on the inner pipe with a bus wire "hose clamp" and the connection covered with heatshrink. The TEFLON® sleeve is then slipped over this connection for high voltage insulation.

At this point the 1" copper shield pipe is positioned over the inner workings, with the grounded end of the coil's copper tubing exiting the shield through a slot in the side. The flexible silicone water hose and coaxial cable are fed through holes in the pipe cap; the coaxial braid is soldered to the inner wall of the shield, and the coax center conductor to the ring on the ceramic assembly. After pressing the pipe cap in place, and centering the ceramic assembly in the shield, the ground tubing is soldered to the shield and the slot filled with solder for a liquid tight seal. A final tuning check is made with a network analyzer with the shield in position, and any necessary pre-encapsulation adjustments are made.

Next, another (~80g) batch of RTV615 is prepared and de-aired in the vacuum chamber as before. With the device held vertically and open at the top, the assembly is slowly filled with RTV615 and then vacuum pumped for about an hour to remove all air bubbles. The vacuum process is complete when air bubbles stop rising to the surface. The device is then removed from the vacuum and cured for 4 hours at 65°C. The longer, lower temperature curing cycle is used because it is below the coaxial cable's maximum temperature rating. After curing and cooling, the second silicone water hose is attached to the copper ground tubing with a bus wire "hose clamp" and the connection covered with heat shrink.

EXAMPLE 2

Tissue tightening *in vitro*

Ovine and human tissue samples were cut into 2cm x 2 cm sections and inductively treated using 400 W power generated from a an ENI 6B power supply operating at 13.6 MHz. The coil was 2 cm in diameter and placed 2 mm from the tissue. Exposure was for 20 – 30 seconds. Samples of lung, artery, and skin demonstrated macroscopic shrinkage of approximately 5-20% depending on length of exposure. Skin and lung samples were placed in formalin and evaluated by thin section histology. Examination of Mason-trichome stained sections demonstrated

that collagen fibrils were packed more closely together in the treated versus untreated sections.

Figure 6 shows measurements taken at 27MHz and 600W. Bovine muscle, bovine fat, ovine skin, and human blood were used for comparison. The tissues were cut to 2x2x5 cm samples. Each sample was placed directly on the cap of the 27MHz device and imaged from above with a Raytek IR thermometer. The device was activated and the time to heat was recorded, (n=3 for each tissue type).

Figure 7 shows porcine fat, muscle and skin were used for comparison. The tissue samples were measured for thickness to ensure consistency between samples. The samples were between 1.5-2.0mm in thickness. The samples were placed on the faceplate which is 4mm thick PVC and imaged from above with a Raytek IR thermometer. The device was turned on and the time for the sample to reach 70°C was recorded. The IR thermometer is limited to recording the tissue surface opposite that which is in contact with the device. Therefore, it is believed that the actual temperature of the tissue was greater than indicated on the graph.

EXAMPLE 3

Tissue tightening and dermal thickening *in vivo*

Rat skin was treated with the magnetic field coil device at 40MHz and 350W power delivery. The device was held juxtaposed to the skin of anesthetized rats until visible shrinkage was evident without cooling (treatment time $t_t=24$ seconds), with cooling (that is, with the refrigerant circulating through the coil and endplate, $t_t=29$ seconds) and at $t_t=27$ seconds. A grid was drawn on the back of the animal prior to treatment and was photographed before and after treatment and post-treatment day one. The image was digitized and the grids were compared down to the pixel for acute shrinkage. The treatment site was biopsied on post-treatment day two for acute wound response and on post-treatment day 21 to ascertain collagen deposition. Temperature of the epidermis was also measured following treatment. After treatment, the temperature of the surface of the skin was at or around 42°C. By measuring the distance between the gridlines on the skin, it was possible to determine that acute shrinkage of 5% with cooling and 8.5% without cooling

occurred. After 1 day, the skin exhibited a sustained shrinkage of 2.5% with cooling and an increase to 15.9% without cooling. Consistent results were obtained with guinea pig skin, which is known to better mimic human dermal tissue. Treated guinea pig skin shrunk 10.9% with cooling and 11.6% without cooling immediately following treatment.

EXAMPLE 4

Tissue Tightening and Dermal Thickening using 27.2 MHz

The dorsa of four Sprague-Dawley rats were shaved, then the skin was inductively treated using 600 W power generated from a 27.2 MHz power supply. The two-turn pancake coil was 1.5 cm in diameter, and placed against the tissue using a 2 mm spacer composed of TEFLON®. Exposure was from 5 to 10 seconds and cooling of the coil was used. Contraction of the tissue was noted after several seconds of treatment. Biopsies were taken at 21 or 28 days, and histologically stained using eosin or Mason Trichome. Biopsied samples at each time point showed a thickening of the dermis as compared to untreated controls, (Figure 8) as well as production of neo-collagen (Figure 9). Figure 10 shows a model of the expected mode of action produced by this inductive heating using alternating magnetic field energy on the collagen within the treated tissues.

Any patents or publications mentioned in this specification are indicative of the levels of those skilled in the art to which the invention pertains. These patents and publications are herein incorporated by reference to the same extent as if each individual publication was specifically and individually incorporated by reference.

One skilled in the art will readily appreciate that the present invention is well adapted to carry out the objects and obtain the ends and advantages mentioned, as well as those inherent therein. It will be apparent to those skilled in the art that various modifications and variations can be made in practicing the present invention without departing from the spirit or scope of the invention. Changes therein and other uses will occur to those skilled in the art which are encompassed within the spirit of the invention as defined by the scope of the claims.

References

Anderson, RR, Arch Dermatol, 2003, 139:787-788.

Bass, et al, Laser Surg. Med. 1995: 17:315-349.

Gilchrest et al., Plast. Reconstr. Surg. 1982; 69:278-83.

Welch et al., Neodymium-YAG Laser in Medicine, Stephen N. Joffe editor, 1983.

WHAT IS CLAIMED IS:

1. A method of inducing a biological effect in a tissue of an individual, comprising the step of:

applying a high frequency alternating magnetic field to said tissue, wherein said magnetic field causes inductive heating in said tissue, wherein said inductive heating causes a biological effect in said tissue in the individual.

2. The method of claim 1, wherein said biological effect in a tissue is coagulation, cauterization, contraction, shrinkage, induction of wound response, production of collagen, or a combination thereof.

3. The method of claim 1, wherein said inductive heating activates collagen repair and growth in said tissue.

4. The method of claim 1, wherein said inductive heating causes coagulation of said tissue resulting in ablation, fusion, improved skin cosmesis, or a combination thereof in said tissue of the individual.

5. The method of claim 4, wherein said improved skin cosmesis is selected from the group consisting of facial rejuvenation, reduced wrinkles, reduced acne, increased hair removal, varicose vein reduction, reduction of cellulite, reduced vascular lesions, or a combination thereof.

6. The method of claim 1, wherein said heat induced in the tissue is controlled by feedback monitoring to control the time of heat induced, or the amount of heat induced, or a combination thereof, in the individual.

7. The method of claim 6, wherein said feedback monitoring is selected from the group consisting of detection of heat in said tissue, detection of eddy currents formed in said tissue, ultrasound detection of said tissue, detection of changes in the impedance in said tissue, or a combination thereof.

8. The method of claim 1, further comprising the step of applying cooling to said tissue of the individual.

9. The method of claim 8, wherein said cooling comprises application of a thermally conductive surface to said tissue.

10. The method of claim 9, wherein said application of a thermally conductive surface comprises circulating coolant through the surface in contact with the tissue, circulating coolant on the exterior of the magnetic field device, applying cryogenic material to said tissue, applying cryogenic material to the surface in contact with said tissue, applying cryogenic material to the exterior of said magnetic field device, or a combination thereof.

11. The method of claim 8, wherein said cooling is applied before, during, or after applying high frequency alternating magnetic field to said tissue.

12. A method of inducing a wound response in tissue in an individual comprising the step of:

applying a high-frequency alternating magnetic field to said tissue, wherein said magnetic field causes the movement of ions in said tissue causing a biological response in said tissue in the individual.

13. The method of claim 12, wherein said biological response is comprised of activation of collagen repair and growth, dermal thickening, or a combination thereof.

14. A device for altering tissue, comprising,
a means of providing a source of radiofrequency energy; and

a means of providing a high frequency alternating magnetic field;
a means of providing a cooling system, and
optionally, a means of controlling said tissue alteration.

15. The device of claim 14, wherein said means for providing said radiofrequency energy is comprised of a radiofrequency power supply.

16. The device of claim 14, wherein said means for providing said high frequency alternating magnetic field is comprised of an induction coil and said radiofrequency energy.

17. The device of claim 14, wherein said means for providing said cooling system is selected from the group consisting of a thermally conductive surface to contact said tissue, a circulating coolant through the thermally conductive surface in contact said tissue, a circulating coolant on the exterior of said the magnetic field device, applying cryogenic material directly to said tissue, applying cryogenic material to the thermally conductive surface, or applying cryogenic material to the exterior of the magnetic field device.

18. The device of claim 14, wherein said means for providing said controlling said tissue alteration comprises feedback monitoring to control the time of heat induced, the amount of heat induced, or a combination thereof.

19. The device of claim 14, wherein said means for feedback monitoring is by detection of heat in said tissue, detection of eddy currents formed in said tissue, ultrasound detection of said tissue, detection of changes in the impedance in said tissue, or a combination thereof.

20. A device for treating tissue, comprising:

a hand piece coupled to the energy output of a radiofrequency generator, whereby said radiofrequency generator produces a high frequency alternating magnetic field, and whereby the hand piece incorporates an impedance matching network, a cooling system, and

optionally a feedback mechanism to ensure proper treatment of said tissue, and

optionally a mechanical tissue-shaper, or pneumatic tissue-shaper, is provided to move said tissue into a different positions and shapes proximal to said hand piece.

21. A device for treating tissue comprising a hand piece coupled to the energy output of a radiofrequency generator, whereby said generator produces a high frequency alternating magnetic field, and whereby the hand piece incorporates an impedance matching network, a cooling system, and a means of controlling the monitoring treatment by the detection of eddy currents, by the detection of an additional source of radiant energy, by the detection of plasma energy, by the detection of acoustic energy, by the detection of bipolar electrosurgical energy, by the detection of monopolar electrosurgical energy, or a combination thereof.

Fig 1

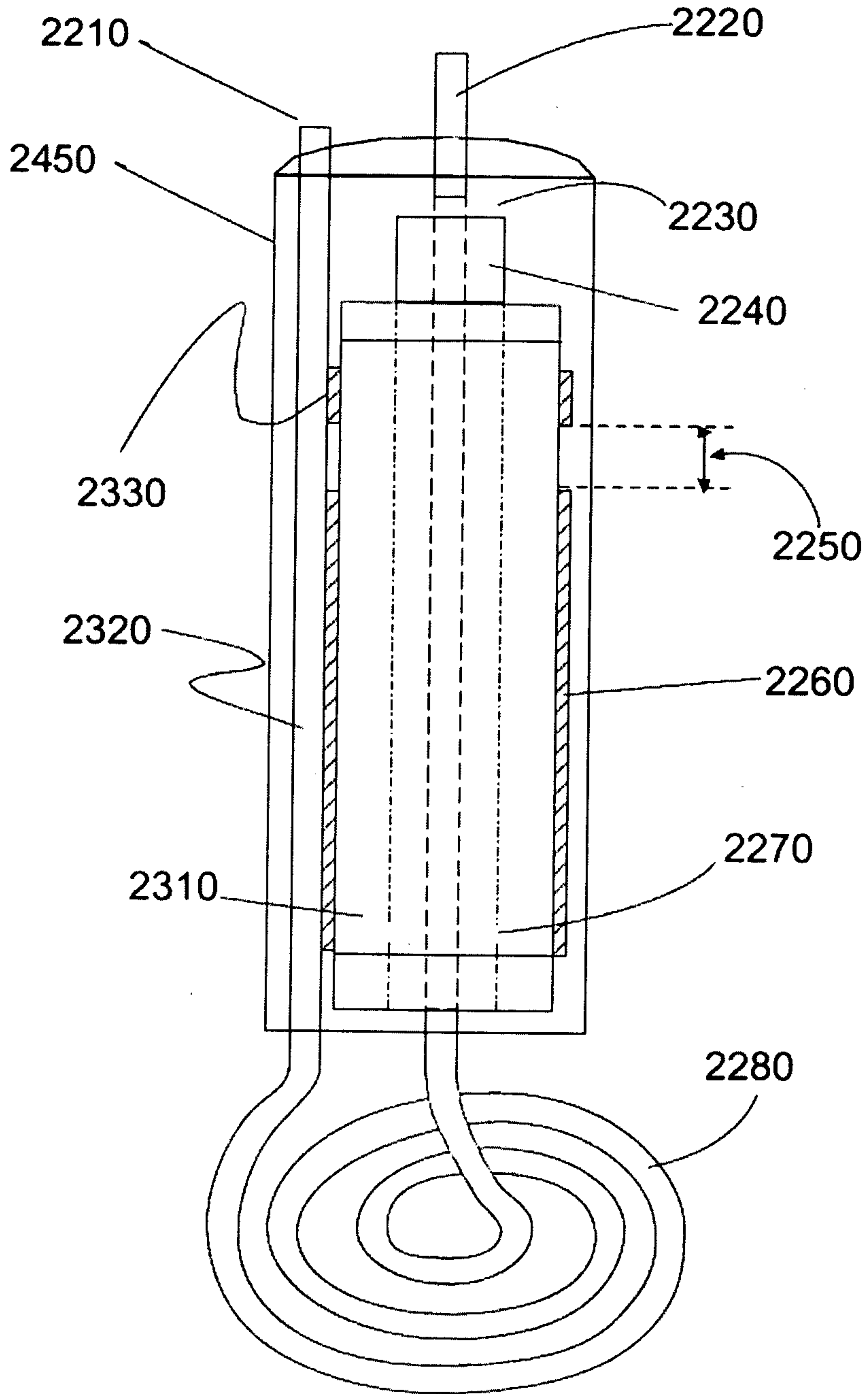

Fig 2

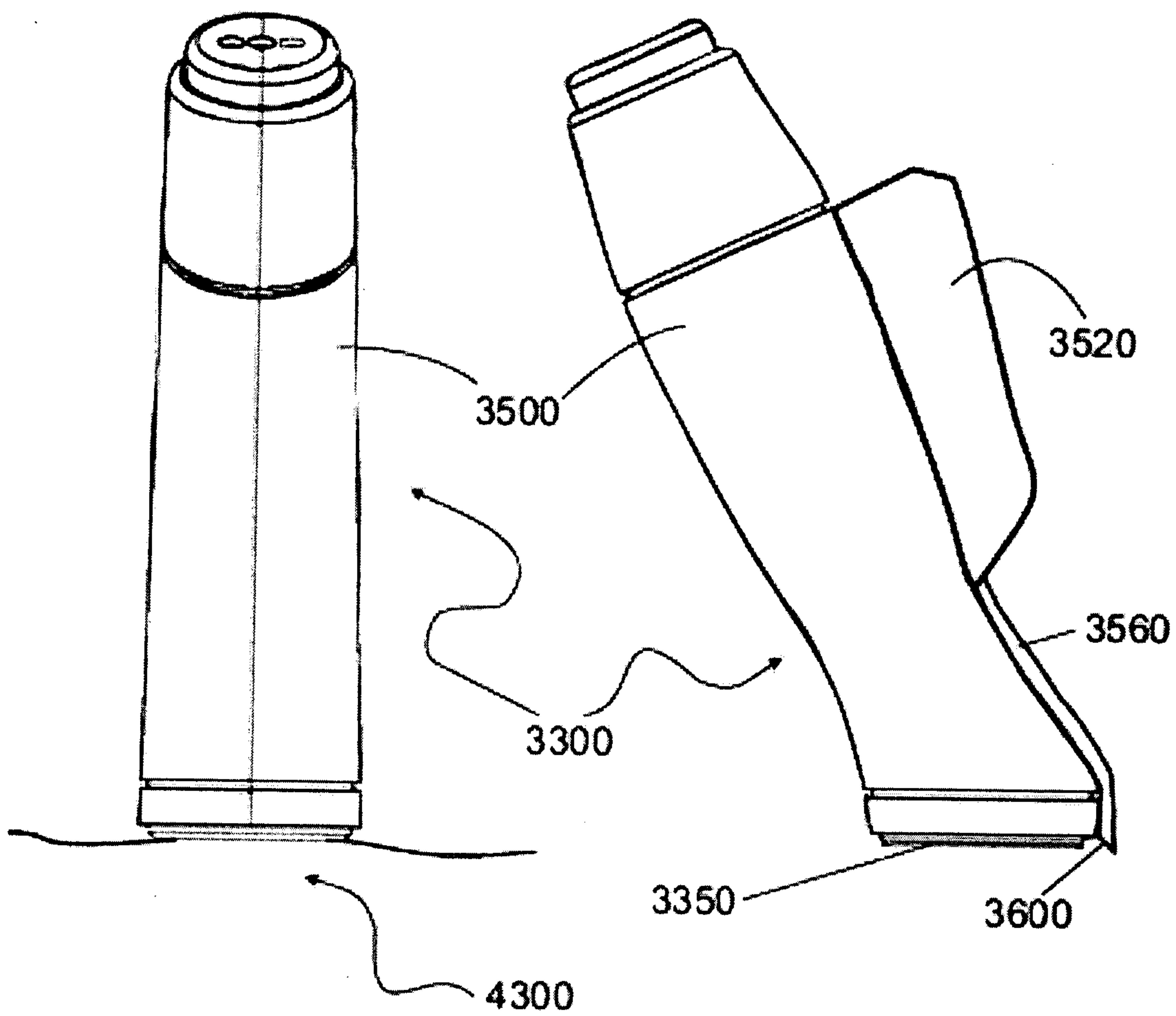

Fig 3

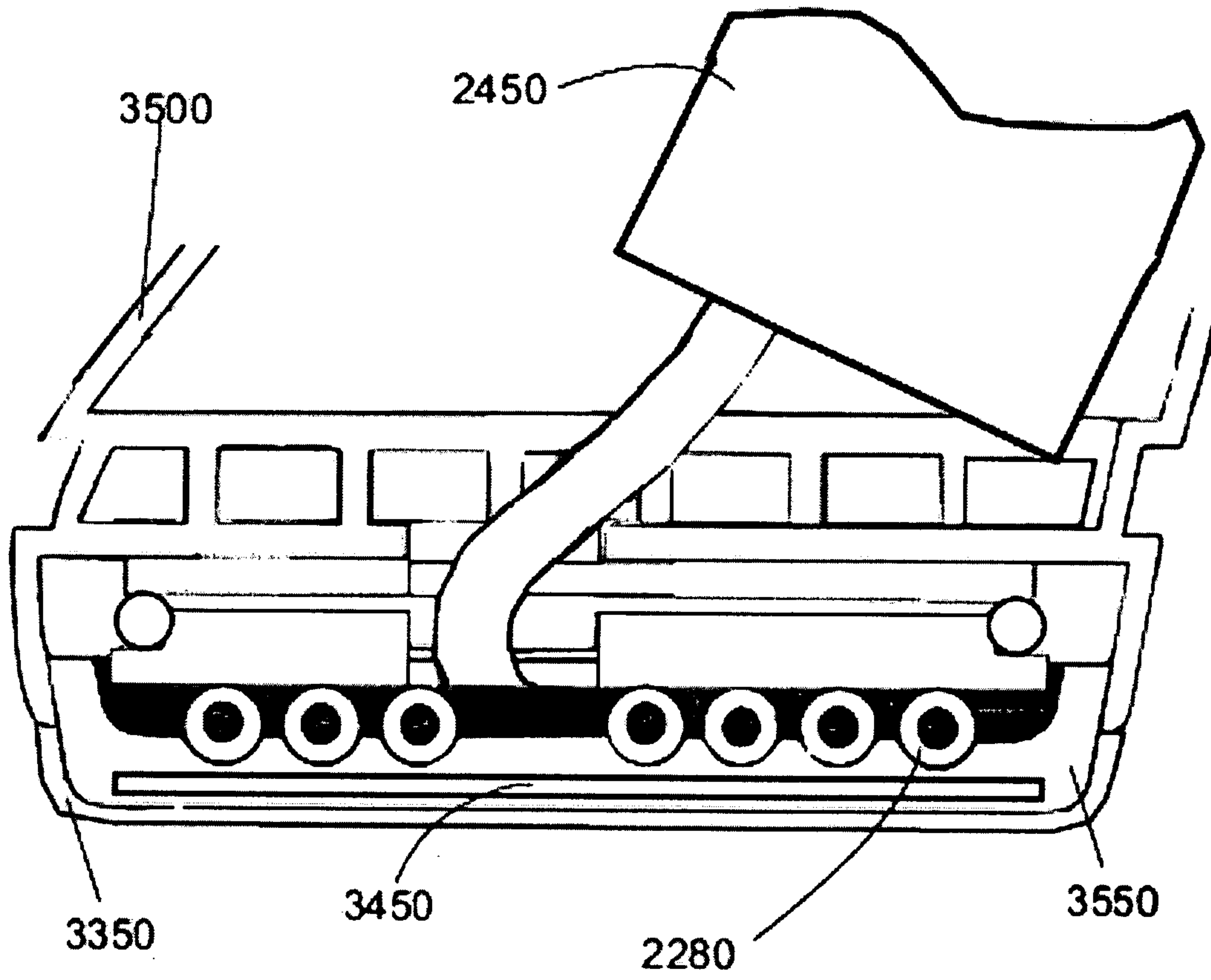

Fig 4

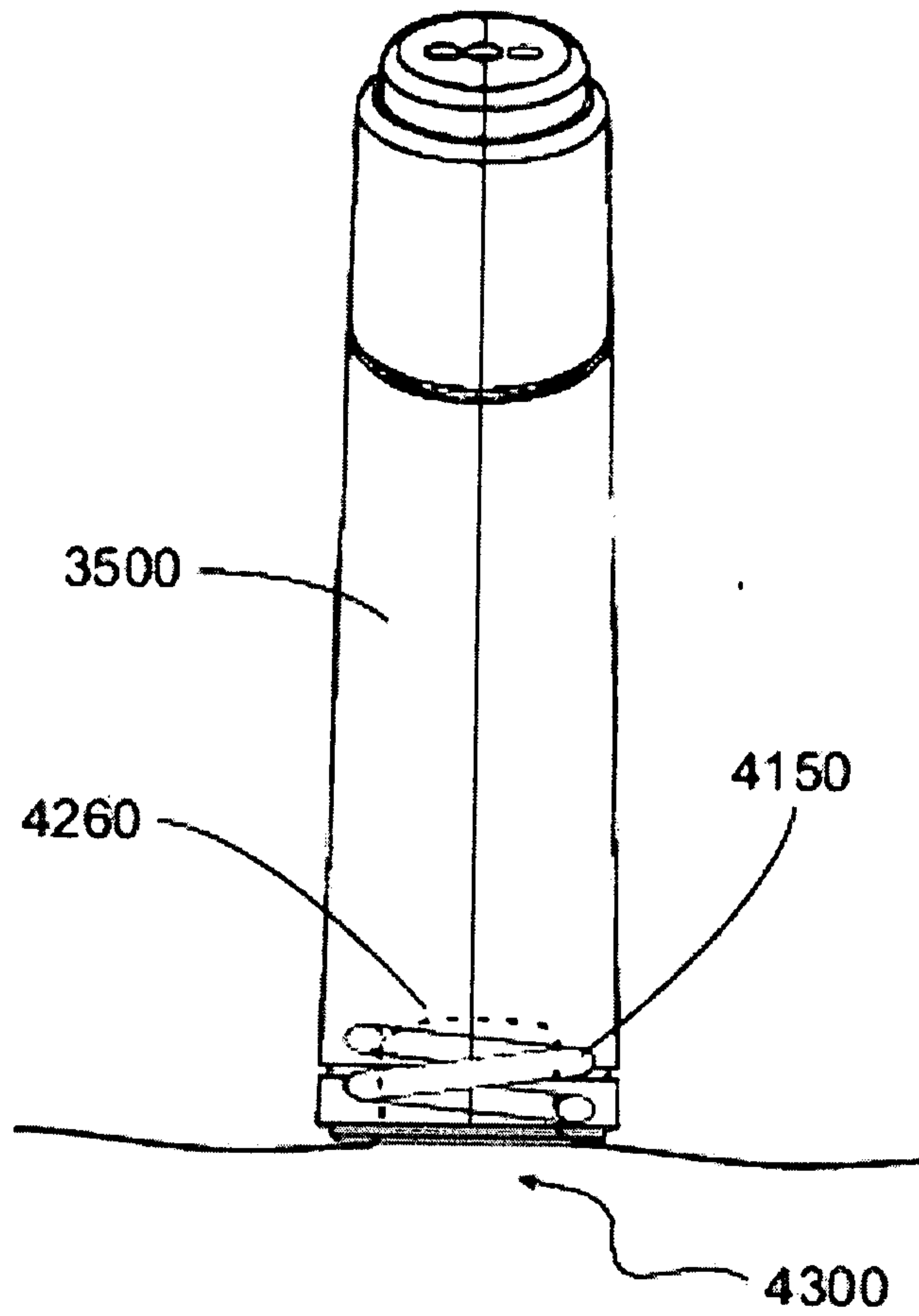

Fig 5

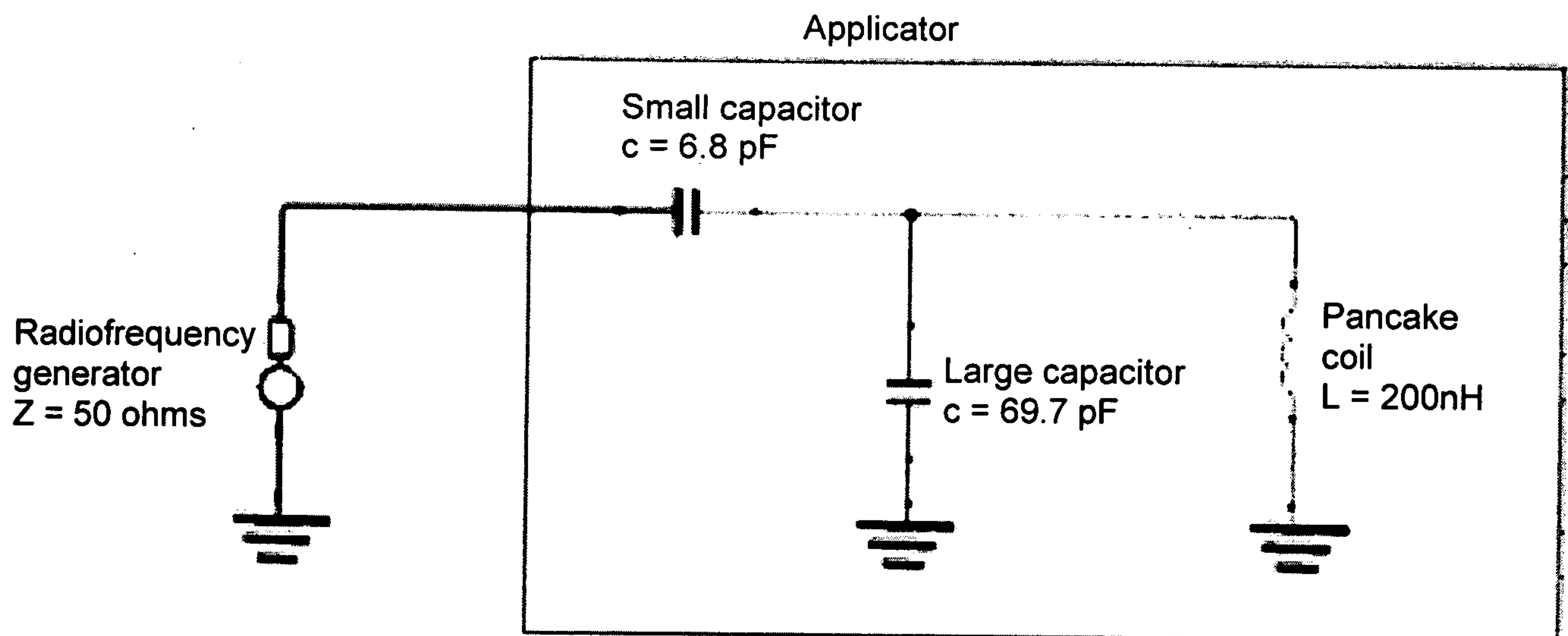

Fig 6

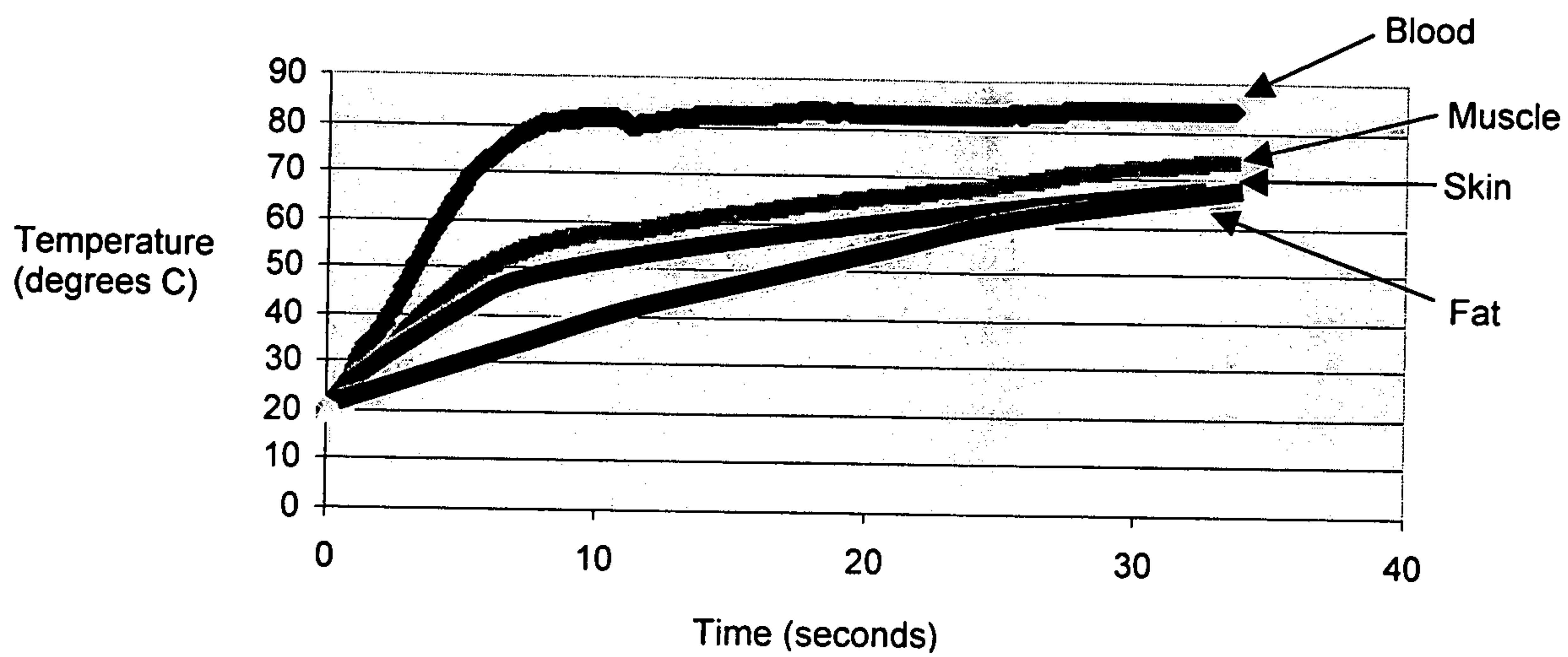

Fig 7

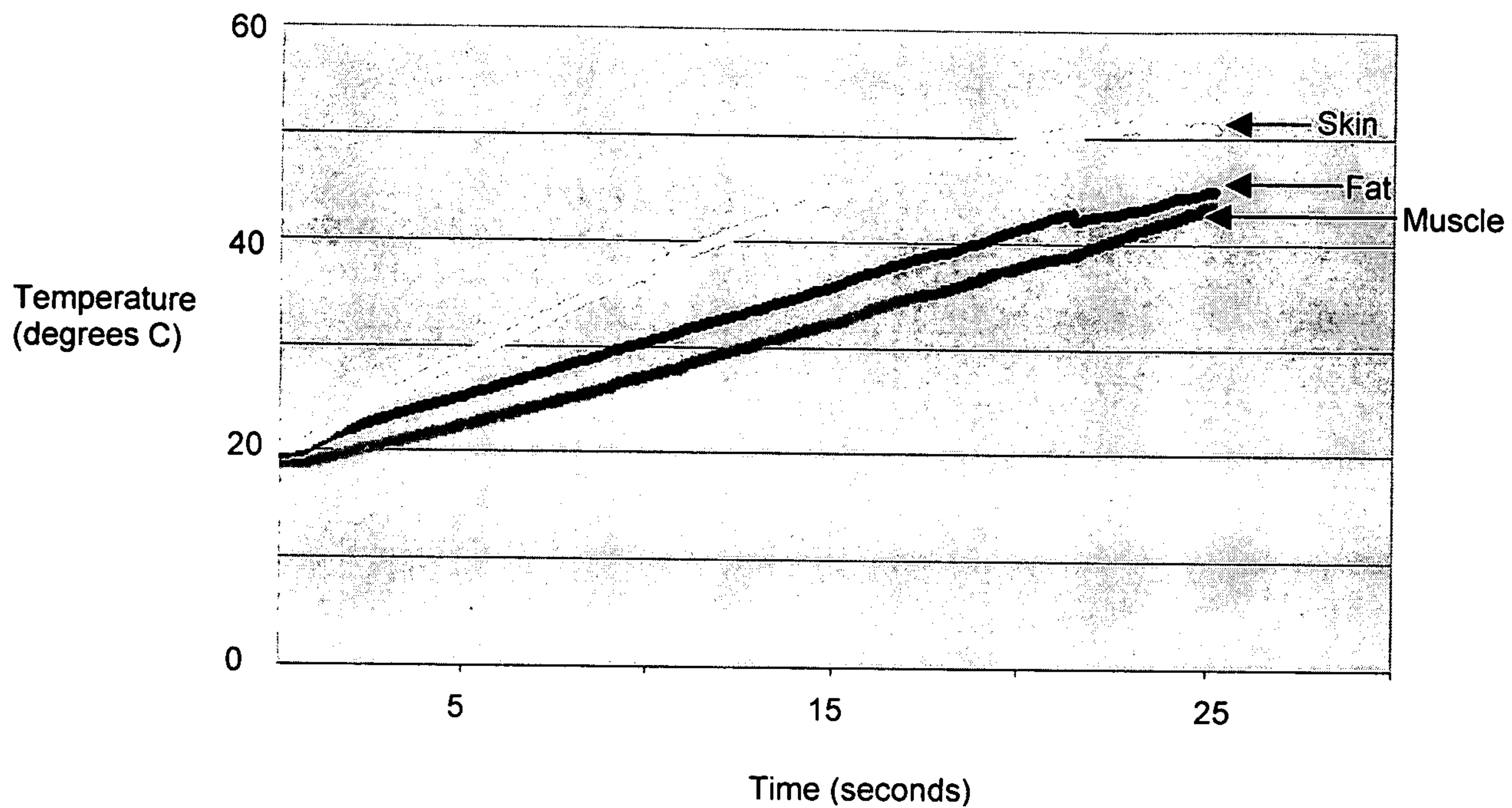
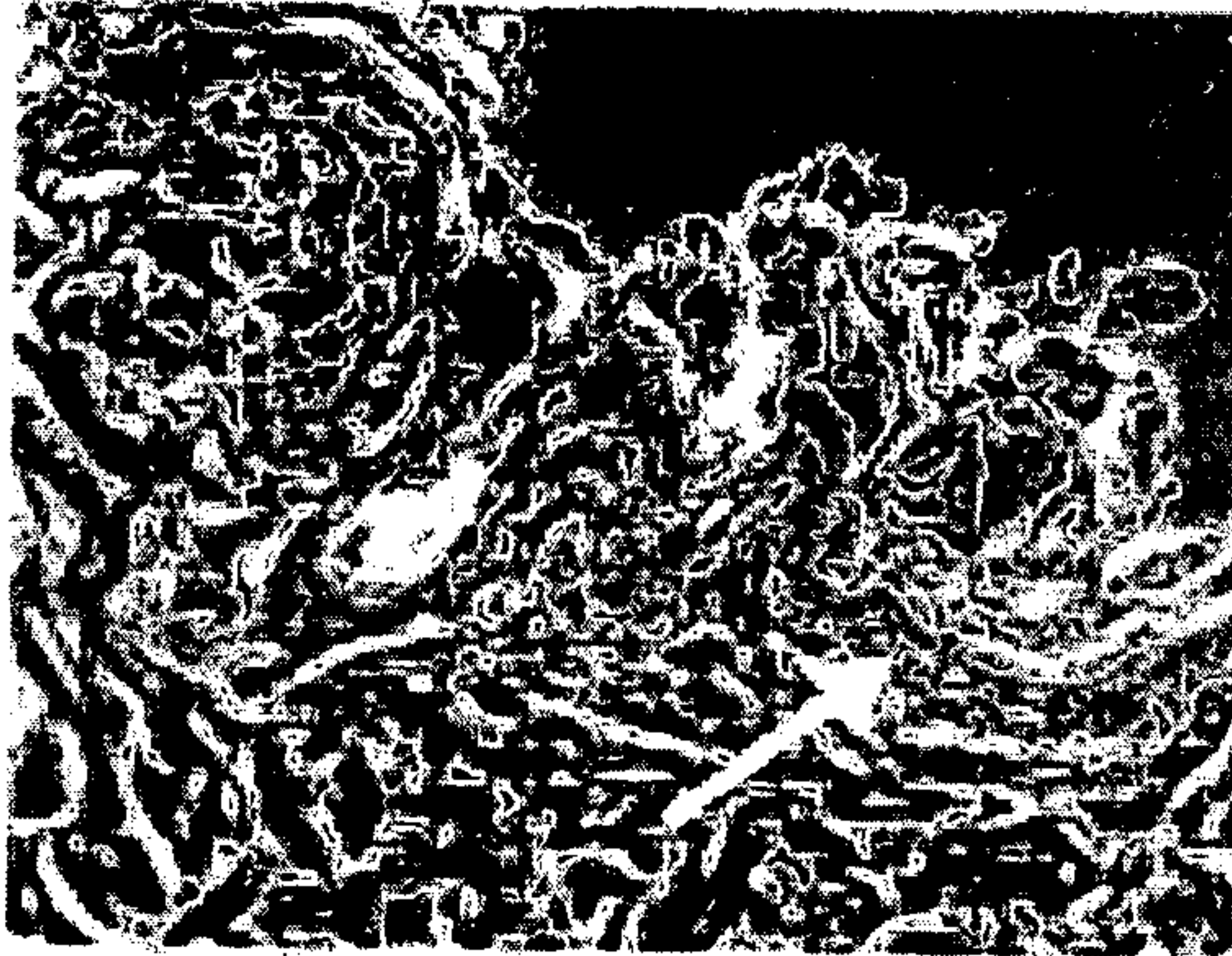
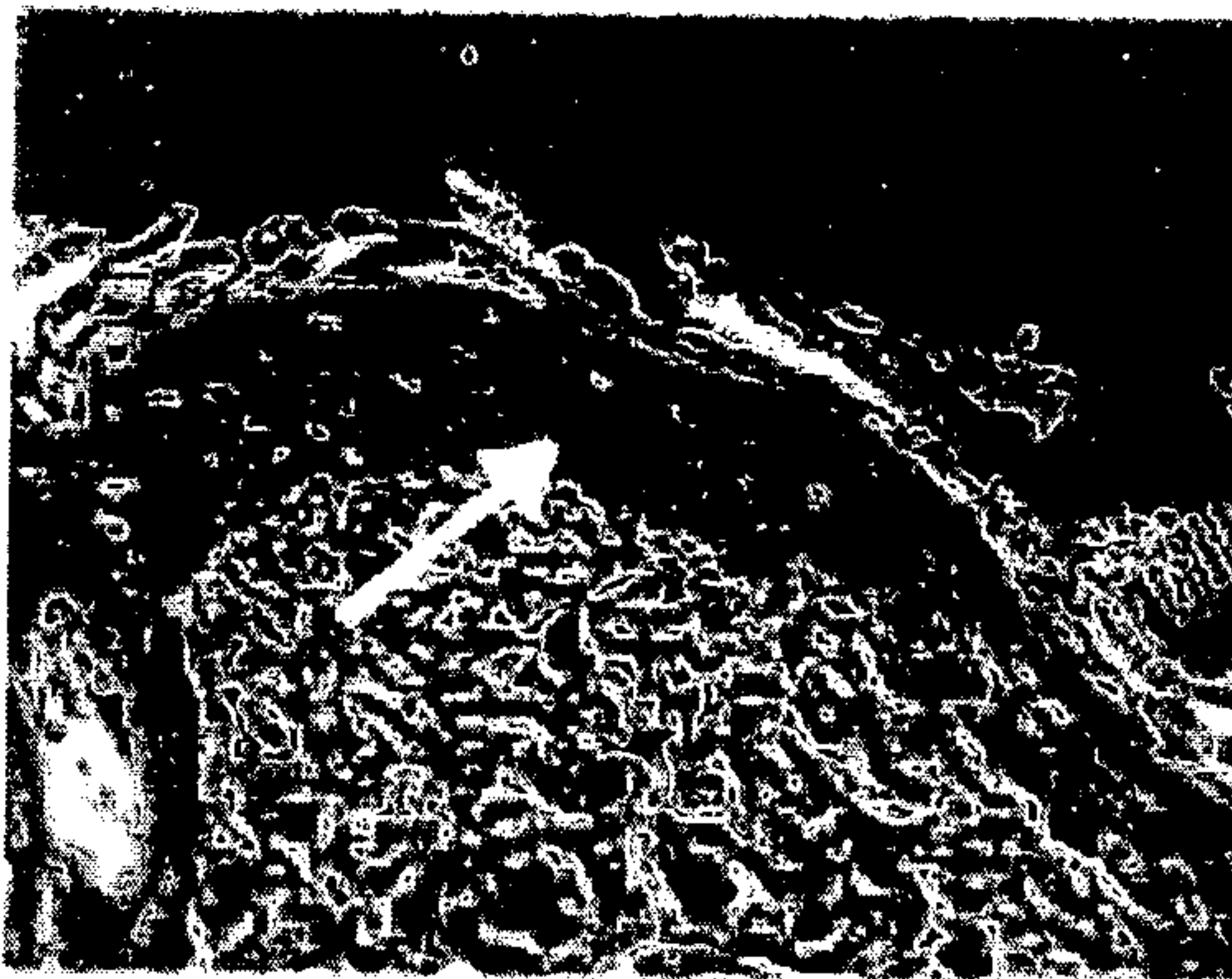

Fig 8



Untreated



Treated + 2 weeks



Treated + 2 weeks

Fig 9

Untreated control



Treated



Fig 10

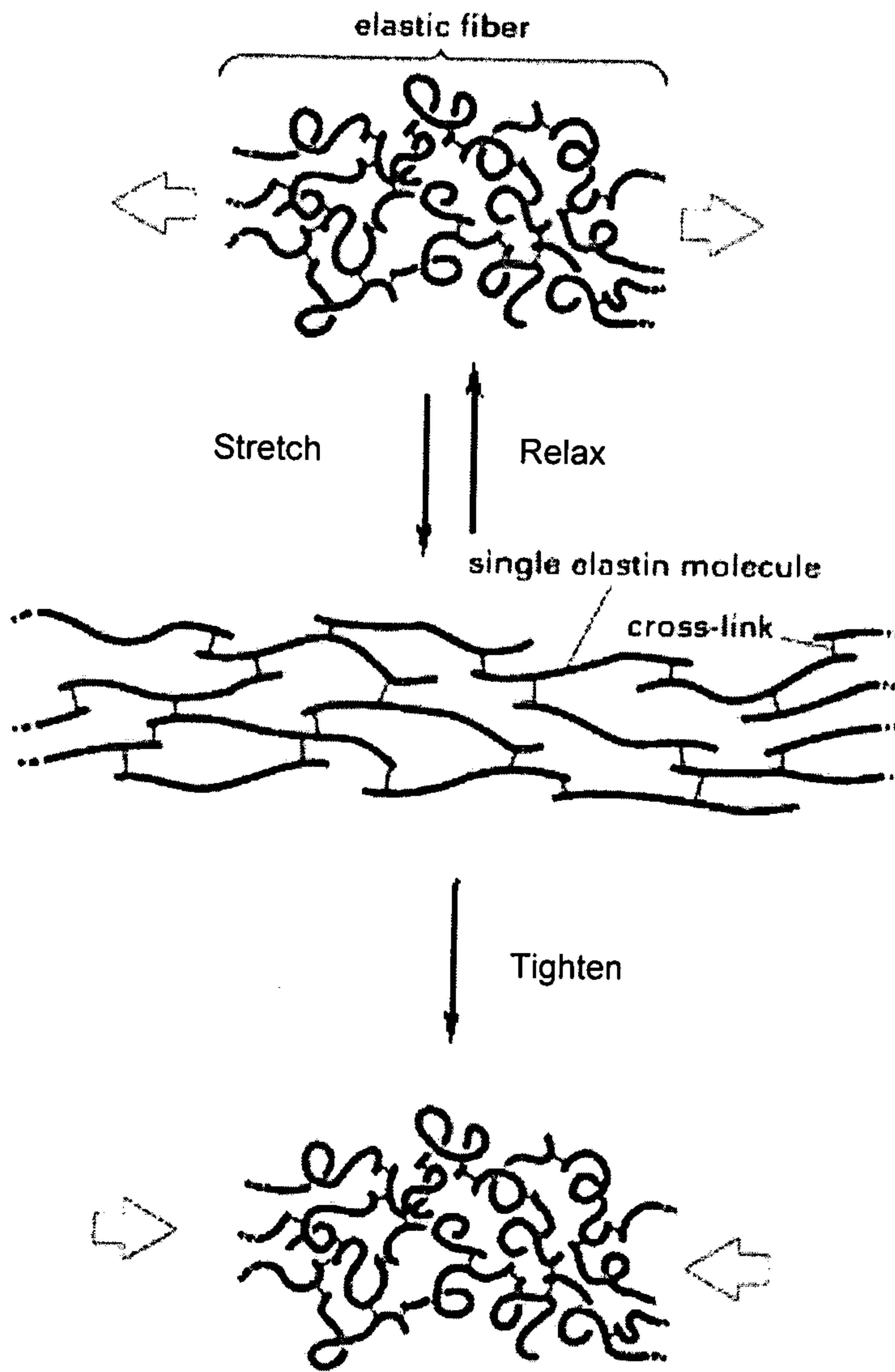

Fig 1

