

(No Model.)

6 Sheets—Sheet 1.

W. ADAM.

LOOM FOR WEAVING CHENILLE OR AXMINSTER CARPETS AND RUGS.

No. 305,496.

Patented Sept. 23, 1884.

Fig. 1.

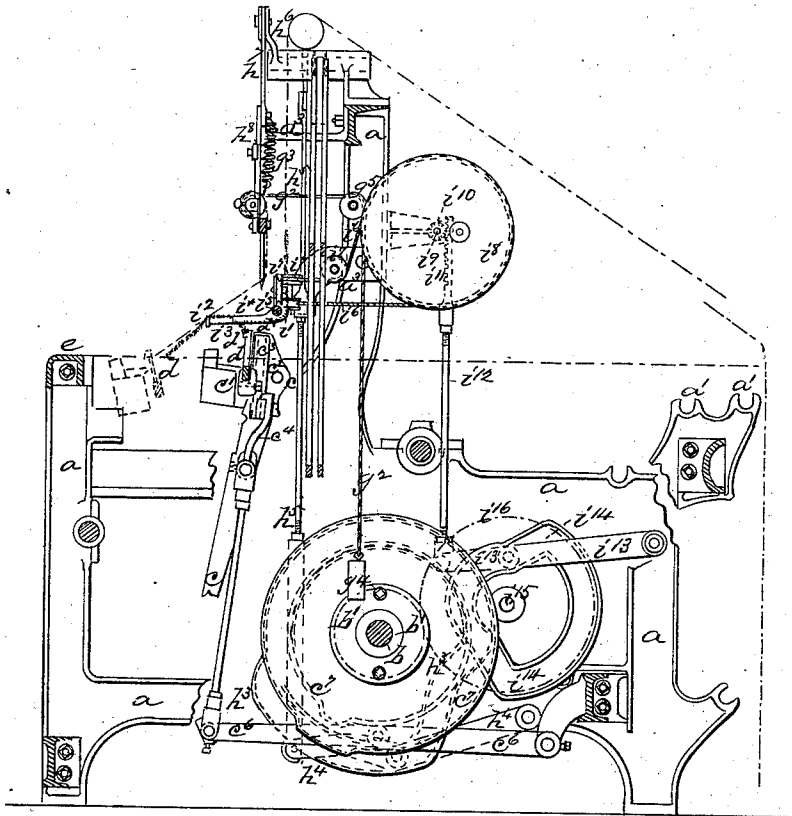

Witnesses:
G. M. Barretto
J. E. Warner

Inventor:
William Adam
by his atty.
C. S. Remwick

(No Model.)

6 Sheets—Sheet 2.

W. ADAM.

LOOM FOR WEAVING CHENILLE OR AXMINSTER CARPETS AND RUGS.

No. 305,496.

Patented Sept. 23, 1884.

Fig. 2.

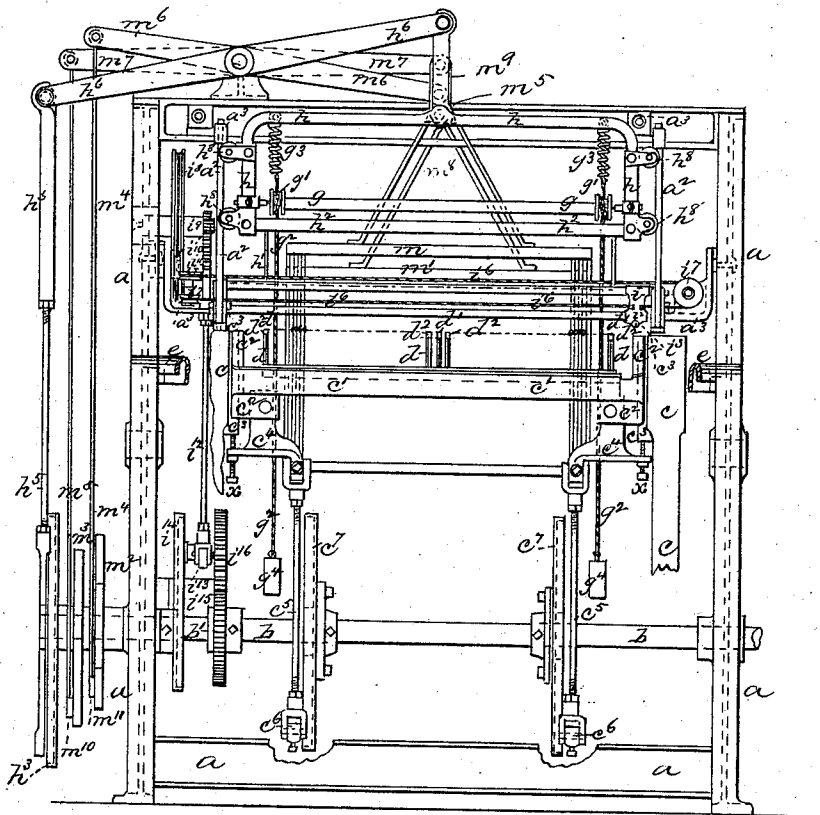

Witnesses.
G. W. Barrett
J. E. Warner

Inventor.
William Adam
by his atty.
C. S. Kemwick

(No Model.)

6 Sheets—Sheet 3.

W. ADAM.

LOOM FOR WEAVING CHENILLE OR AXMINSTER CARPETS AND RUGS.

No. 305,496.

Patented Sept. 23, 1884.

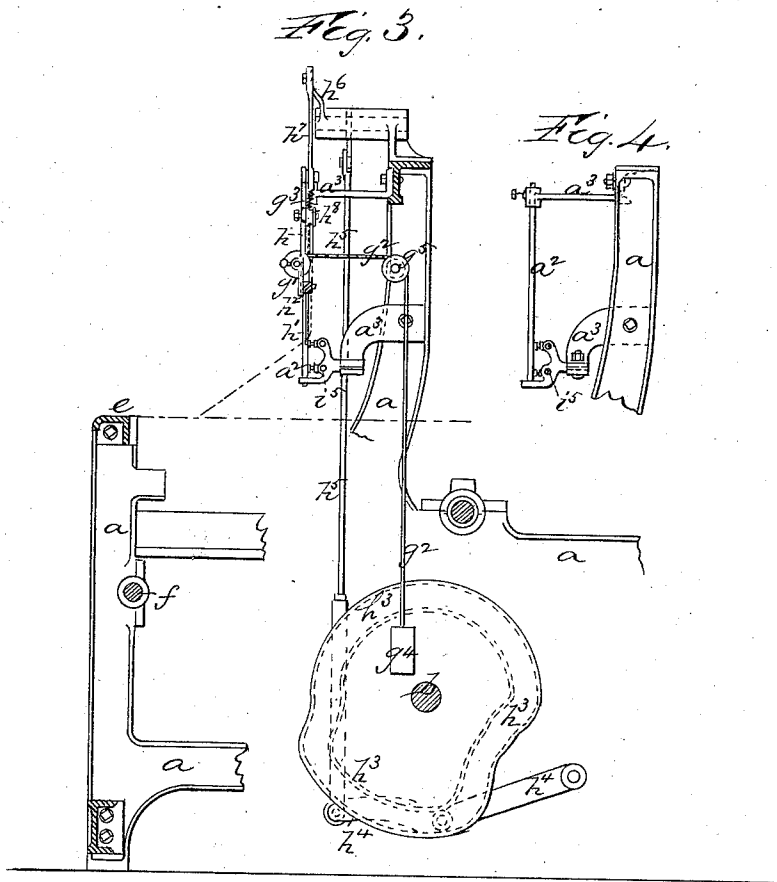

Witnesses.
G. M. Barretto
J. E. Warner

Inventor:
William Adam
by his atty.
C. S. Remick

(No Model.)

6 Sheets—Sheet 4.

W. ADAM.

LOOM FOR WEAVING CHENILLE OR AXMINSTER CARPETS AND RUGS.

No. 305,496.

Patented Sept. 23, 1884.

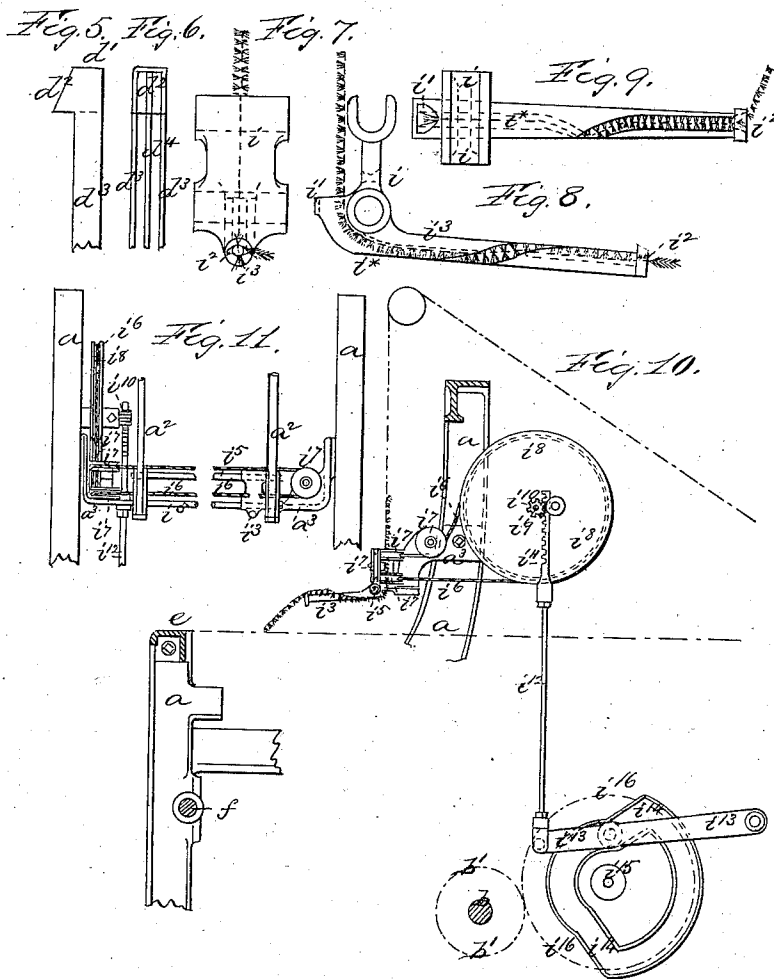

Witnesses.
G. W. Barretto
J. E. Warner

Inventor:
William Adam
by his atty.
C. S. Remwick

(No Model.)

6 Sheets—Sheet 5.

W. ADAM.

LOOM FOR WEAVING CHENILLE OR AXMINSTER CARPETS AND RUGS.

No. 305,496.

Patented Sept. 23, 1884.

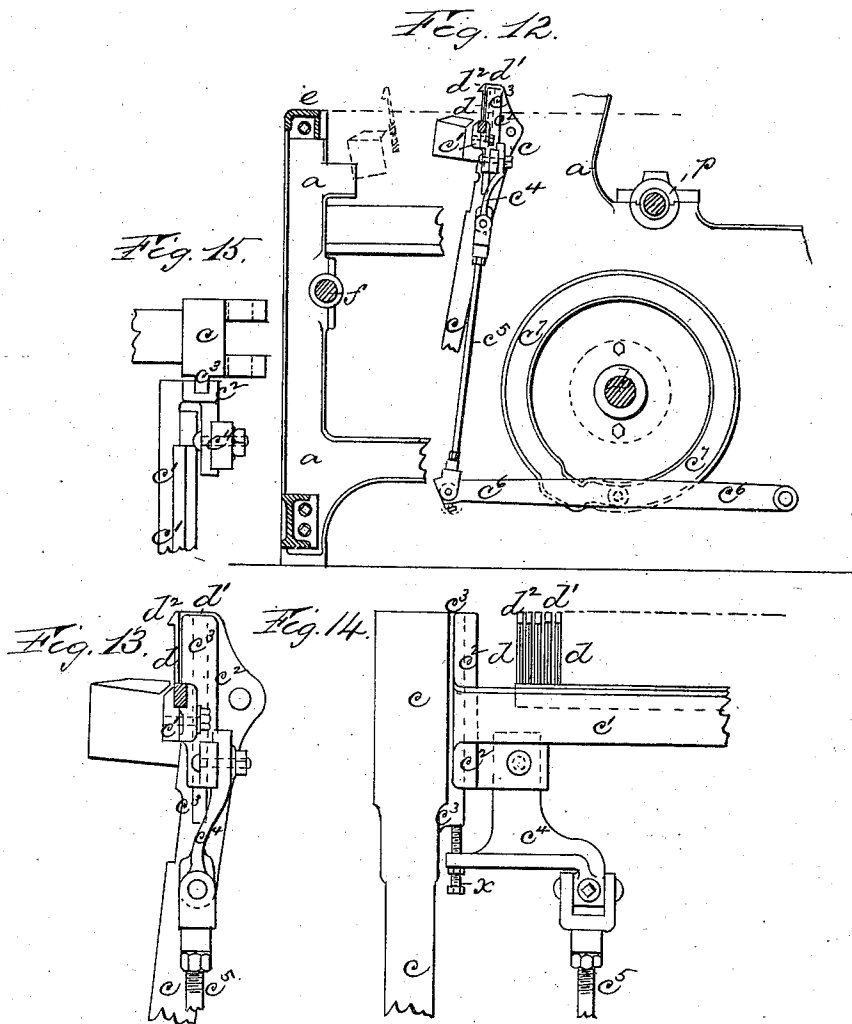

Witnesses,
G. M. Barretto
J. E. Warner

Inventor
William Adam
by his Atty.
O. S. Kenwick

(No Model.)

6 Sheets—Sheet 6.

W. ADAM.

LOOM FOR WEAVING CHENILLE OR AXMINSTER CARPETS AND RUGS.

No. 305,496.

Patented Sept. 23, 1884.

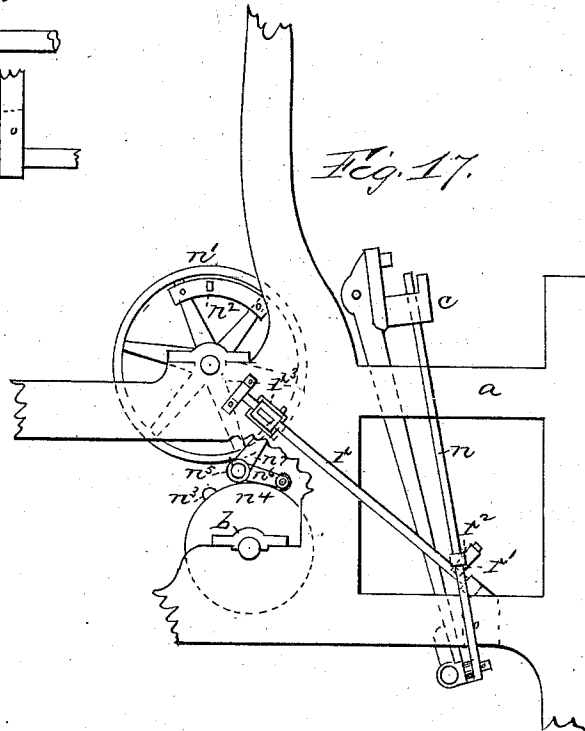
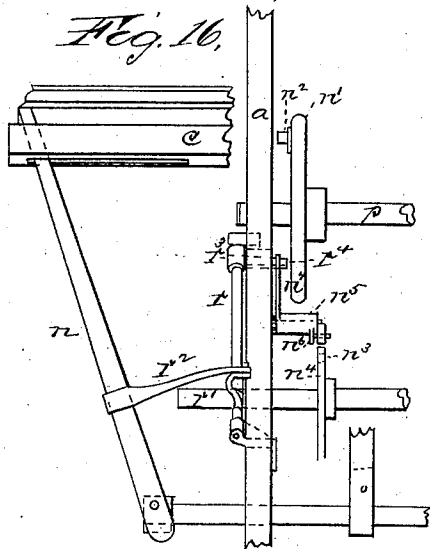
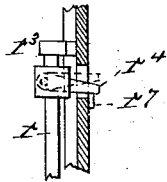

Fig. 18.



Witnesses,
 H. W. Barretto
 J. E. Warner

Inventor,
 William Adam
 by his Atty.
 C. S. Kenwick

UNITED STATES PATENT OFFICE.

WILLIAM ADAM, OF KIDDERMINSTER, COUNTY OF WORCESTER, ENGLAND.

LOOM FOR WEAVING CHENILLE OR AXMINSTER CARPETS AND RUGS.

SPECIFICATION forming part of Letters Patent No. 305,496, dated September 23, 1884.

Application filed September 11, 1883. (No model.) Patented in England November 22, 1880, No. 4,842.

To all whom it may concern:

Be it known that I, WILLIAM ADAM, of the firm of Tomkinson & Adam, carpet and rug manufacturers, a subject of the Queen of Great Britain, residing at Kidderminster, in the county of Worcester, England, have invented certain new and useful Improvements in Looms for Weaving Chenille or Axminster Carpets and Rugs, of which the following, in connection with the accompanying drawings, is a full, clear, and exact description.

The invention has for its object improvements in looms for weaving chenille or Axminster carpets and rugs, whereby greater speed than heretofore is obtained in the weaving of such description of carpets and rugs. This class of goods consists of a ground fabric, to the upper surface of which rows of colored tufts are secured by the operation of weaving. The ground fabric is composed of ground-warp threads extending longitudinally of the fabric, and of a filling or weft, which may be interwoven by means of heddles and a shuttle, in the usual manner. The rows of colored tufts are formed in a long cord or strand, commonly called "chenille weft or fur," which is crossed to and fro over the ground-warps in the loom, and is securely connected with the ground fabric by means of supplementary warp-threads called "catcher-warp," which, extending in the length of the fabric over the rows of chenille, are interwoven with the ground fabric between the said rows. According to my present invention, I am enabled successfully to weave the chenille weft or fur from a beam or bobbin or from a basket.

My original invention consisted of certain new and useful combinations of the devices of a loom, and was divisible into two divisions. One division of my said invention is described in the English Letters Patent No. 4,842, granted to me November 22, A. D. 1880, and is also described in the Letters Patent of the United States No. 263,085, granted to me August 22, 1882. The other division of my said original invention is described by the drawings and specifications of both my said patents, but is not claimed in my said American patent. It consists of the improvements, which are hereinafter described and claimed.

In carrying my invention into effect I employ at least two leaves of heddles, or their equivalents, to control the ground-warps, and a shuttle operated by picker-staves, or its

equivalent, to carry and introduce the ground weft or filling. I also prefer to employ the precise means and mechanism described in the said Letters Patent No. 263,085 for operating the catcher-warps, introducing the chenille or fur, and beating up the fabric; but this division of my invention is not restricted to the said means and mechanism, as the improvements recited in the claims at the close of this description may be embodied by the use of means and mechanism varying from those recited in the claims of my said American Patent No. 263,085.

For operating the catcher-warp, I employ a row of needles set on a bar to the required gage, and through the eyes of which the threads of the catcher-warp pass from a small roller or bobbin with flanged ends, on which it is wound. The bar of needles is by preference fixed to a frame mounted with capability of being moved up and down in suitable fixed guides carried by the framing of the loom. The catcher-warp roller or bobbin is by preference mounted in bearings carried by the needle-frame just above the needle-bar, and moves up and down with it, and such catcher-warp roller or bobbin is provided at one or both ends thereof with suitable letting-off and taking-up appliances. In order to allow the catcher-warps to enter their respective spaces in the reed, the latter is made in the form of a comb, with spaces at intervals, through which the threads of the catcher-warp pass. The tops of the dents between the open-top spaces are united together and filled in solid, and I prefer to form the outer dents in one strip of metal, bent over at the top in order to give increased strength to such parts. When my entire invention is used, I also form the front or face of such solid tops inclined slightly forward from the upper to the lower part thereof, for the purpose hereinafter described. The chenille weft or fur is wound on a beam or large bobbin, or it may be placed in a basket. The beam, bobbin, or basket is placed in any convenient position, and the end of the chenille weft or fur is passed through one or more guides carried by a finger or weft-guide that is, by preference, fixed to a slide which runs to and fro on one or more guide rods or bars fixed to the loom behind the catcher-warp needles, and such slide is moved at the required times from one side of the loom to the other, with the projecting finger

traveling between the top of the reed and the points of the catcher-warp needles, whereby the chenille weft or fur will be carried across the loom in front of the reed, ready to be pulled by the attendant to the fell of the work. The reed is then moved forward, and preferably in such a position that the bottom edge of the solid tops of the reed shall ride upon the ground-warps and press the chenille weft or fur to its proper place, to assist which the reed has a rising motion imparted to it just as the lathe is completing its forward motion, thus bringing the fur to its proper place without the aid of a comb, which it has hitherto been found necessary to employ in this class of looms. When beating up the ground-weft the reed is moved to and fro in the ordinary manner; but when pressing the chenille weft or fur to its place I prefer that the motion above described shall be imparted to it.

The slide employed in carrying the chenille weft or fur into the open shed may be operated in any convenient manner; but the way I have found to answer consists in attaching one end of a cord or other flexible connection to one side and the other end of the cord to the other side of the slide, and passing such flexible connection partly around wheels or pulleys at each side of the loom, whence it passes to a wheel which receives the required reciprocating rotary motion at the proper times from a cam and suitable connections.

The improvements which constitute this division of my invention consist of certain combinations of mechanical devices for operating upon the ground-warps, the ground weft or filling, the catcher-warp, the chenille or fur, and for beating up the fabric. These improvements are recited in the claims at the close of this description, and in order that they may be clearly understood and readily carried into effect, I will proceed, aided by the accompanying drawings, more fully to describe the principal parts of a loom embodying the same.

In the drawings, Figure 1 is a vertical cross-section, and Fig. 2 is a front elevation, of so much of a loom for wearing chenille or Axminster carpets and rugs as will enable me to describe my present improvements; and Figs. 3, 4, 5, 6, 7, 8, 9, 10, 11, 12, 13, 14, 15, 16, 17, and 18 are various views more clearly illustrating various portions of my invention.

a a represent the framing of the loom; *b*, the cam-shaft; *c*, the lathe with its swords; *d*, the reed; *e*, the breast-beam, and *f* the axis of the work-beam. The warps to form the ground of the fabric are carried by beams mounted in bearings *a'*, in the usual manner. These ground-warps are passed through the eyes of two leaves of heddles, which are arranged in two heddle-frames, *m m'*, a part only of the heddles being shown in the drawings for greater perspicuity. Each of these heddle-frames is raised and lowered at the proper time in the operation of the loom (as hereinafter described) by means

of a heddle-cam, *m²* or *m³*, which are secured to the cam-shaft *b* of the loom, and are caused to operate their respective heddles through the intervention of levers *m¹⁰ m¹¹*, rods *m⁴ m⁵*, overhead levers *m⁶ m⁷*, and links *m⁸ m⁹*. The ground weft or filling is carried by a shuttle which is fitted to travel to and fro in a shuttle-race secured to the lathe *c*, and is operated by means of picker-staves *n*, Figs. 16 and 17. These picker-staves may be driven in any suitable manner; but I prefer to drive them from the driving-shaft *p* of the loom by means of the following connecting mechanism: A rock-shaft, *r*, is fixed to each side of the frame of the loom in suitable bearings. Near the lower end of each rock-shaft an arm, *r'*, projects upward, to which a strap, *r²*, is attached, one end of the strap being attached to the picker-staff *n*. Near the upper end of each rock-shaft *r* there is an enlargement, *r³*, through which is a slot, in which works a tongue, *r⁴*, hung on a pin passing through the enlargement of the shaft, so as to be capable of vibrating lengthwise of said shaft. This tongue projects through an opening in the frame of the loom in a position to be struck by the projection *n²* on the cam-wheel *n'* on the driving-shaft *p*.

As the driving-shaft revolves a number of times for each pick or passage of the weft by the shuttle, it is necessary to move the tongue out of the track of the projection, except at the moment when the shuttle is to be thrown. For this purpose the tongue *r⁴* is made with considerable play lengthwise of its rock-shaft *r*, so that the inner end of the tongue may drop by its own weight toward the lower end of the slot in the loom-frame; or, if necessary, the dropping may be assisted by a spring. When the tongue *r⁴* is down, it is out of the range of the tappet or cam projection *n²* of the cam-wheel *n'*, and the picker-staff is not operated. Whenever the picker-staff is to be operated, the inner end of the tongue *r⁴* is raised within the range of the projection *n²* of the cam-wheel *n'* by means of a cam projection or tappet, *n⁵*, which projects from another cam, *n⁴*, that is secured to the cam-shaft *b*. This cam projection *n²* operates upon the tongue *r⁴* through the intervention of the rocking lever *n⁵*, which is pivoted upon a stud secured to the frame, with one of its arms, *n⁶*, within the range of revolution of the cam projection *n³*, and with its other arm, *n⁷*, beneath the tongue *r⁴*.

The devices above described are represented as attached to the left-hand side of the loom, and are employed to operate the left-hand picker-staff. Corresponding devices are applied to the right-hand side of the loom to operate the right-hand picker-staff, the cam projection for that side corresponding with the cam projection *n³*, being secured to its respective cam-wheel in the proper position to cause the right-hand picker-staff to be operated at the required time for throwing the shuttle from that side of the loom.

The catcher-warp may be wound upon a

beam or roll at the rear of the loom; but I prefer to wind it upon a small roller which is mounted in the frame that carries the catcher-warp needles, so that this roller may move up and down with the said needles. This arrangement of the catcher-warp roller is shown at Figs. 1, 2, and 3, where the catcher-warp roller *g* is represented as constructed with flanged ends. This roller or bobbin is provided with a pulley, *g'*, at each end thereof, and is mounted in bearings carried by the needle-frame *h*, mounted with capability of being moved up and down in or upon fixed guides *a'*, which are carried by brackets *a''*, fixed to the main framing of the loom; or such guides may be formed and fixed in other suitable manner, so long as the frame *h* in its motions is correctly guided. Around each of the pulleys *g'* is passed a cord, *g''*, one end of which is attached to the spring *g'''*, connected with the needle-frame, and the other end to a weight, *g''''*. The said cords *g''* are also passed over guide-pulleys *g''''*, mounted in any convenient position. By these means the catcher-warp has suitable friction applied thereto, and may be drawn off the roller or bobbin *g*, as required for the work, while the slack of the catcher-warp is taken up as required. The catcher-warps are passed through the eyes of needles *h'*, fixed to a bar, *h''*, carried by the sliding frame *h*, and the frame *h* is moved up and down at the required times in the following manner, (see Figs. 1, 2, and 3:): On the cam-shaft *b* is fixed a cam, *h'''*, which gives motion to a lever, *h''''*. The latter is, by link or connecting-rod *h''''''*, connected to one end of a lever, *h''''''''*, the other end of which is, by a link, *h''''''''''*, connected to the sliding needle-frame *h*.

In the drawings I have represented the needle-frame *h* as provided with guide wheels or rollers *h''*, to run against the guides *a'*; but, if desired, the needle-frame *h* may be otherwise guided and the fixed guides may be otherwise formed, provided the needle-frame *h* is rigidly controlled in its motions.

In order that the catcher-warps may enter their respective places in the reed *d*, the latter is made somewhat in the form of a comb, with spaces at intervals, through which the catcher-warp passes when depressed in order to make a shed. The usual hand-rail of the lathe is dispensed with, and the reed is supported only at the lower part thereof. The tops *d'*, Figs. 5 and 6, of the dents *d'' d'''*, between the open-top spaces, are united together and filled in solid with tin, iron, solder, lead, or with any suitable material; and I prefer to form the outer dents, *d''*, of each section of the reed *d*, as shown more clearly at Figs. 5 and 6, in one strip of metal bent over at the top, in order to give increased strength to such parts. I also prefer to form the front or face *d''''* of such solid tops inclined slightly forward from the upper to the lower part thereof, for the purpose hereinafter described.

The chenille weft or fur is wound on a beam or large bobbin, or may be placed in a basket. The beam, bobbin, or basket is placed

in any convenient position, and the end of the chenille weft or fur is passed through guides *i'* *i''*, formed on or fixed to a traveling finger, *i'''*, carried by a slide, *i*, (shown separately at Figs. 7, 8, 9,) which runs to and fro crosswise of the loom, and is guided by rods or bars, *i''''*, fixed to the loom behind the catcher-warp needles *h'*. The chenille weft or fur, in its passage from the eye or guide *i'* to the eye or guide *i''* at the outer end of the finger *i'''*, is preferably guided by passing along a groove or channel, *i''''''*, formed, as shown, in the finger *i'''*, to deliver the fur or chenille in the proper position and without putting twist therein. The finger-slide *i* is moved, as hereinafter described, at the required times, from one side of the loom to the other, causing the finger *i'''* to carry the chenille weft or fur with it in front of the reed, ready to be pulled to the fell of the work at the end of its course. Cord *i''''*, fixed to each side of the slide *i*, is passed around guide wheels or pulleys *i''''''*, one end of the cord passing to the top, the other end to the bottom, of a wheel, *i''''''''*, which wheel is fixed on a shaft or axis, *i''''''''''*, as shown in Fig. 2. The said cord *i''''* is then carried around such wheel *i''''''''* a suitable distance and fixed thereto. At one end of the said shaft or axis *i''''''''''* is fixed a toothed pinion, *i''''''''''''*, which is taken into by and receives rotary motion first in one direction and then in the other, at the desired times, from a toothed rack, *i''''''''''''''*, fixed on the upper end of a rod, *i''''''''''''''''*. This rod *i''''''''''''''''* is at its lower end pin-jointed to a lever, *i''''''''''''''''''*, operated by a cam, *i''''''''''''''''''''*, which is fixed on a counter-shaft, *i''''''''''''''''''''''*, receiving rotary motion from the cam-shaft *b* by toothed wheels *b'* and *i''''''''''''''''''''''''*. By these means rotary motion is given to the shaft or axis *i''''''''''''''''''''''* and consequently to the wheel *i''''''''''''''''''''''* at the required times, first in one direction and then in the other, and as the cord *i''''* passes back and forth on the pulleys *i''''''''* in contrary directions, it follows that while going one way it will pull the slide *i* and the traveling finger *i'''* across the loom in one direction, and when going the other way it will pull the slide *i* and traveling finger *i'''* across the loom in the opposite direction, at the required time. The ends of the cord *i''''* are passed through holes in the rim of the wheel *i''''''''*, and are there fixed by clamps, staples, screws, or in any other manner convenient. The wheel is formed with a flat surface, and is flanged to prevent the cord running off, and such cord is caused to take, preferably, two turns around the wheel *i''''''''*, so as to enable such wheel to give the required motion.

The reed *d*, when beating up the chenille weft or fur is preferably moved forward in such a position that the bottom edge of the solid tops *d'* of the dents shall ride upon the ground-warp and press the chenille weft or fur to its proper place, to assist which I prefer to impart to the lathe or the reed *d* a rising motion just as it is completing its forward motion, thus bringing the chenille weft or fur to its proper place without the aid of a comb, which it has been found necessary previous to

my invention to employ in this class of loom. When beating up the ground-weft, the reed is moved to and fro in the ordinary manner; but when pressing the chenille weft or fur to its place the motions above described are imparted to it.

The peculiar motion to the reed above described for pressing the chenille weft or fur to its proper place may be given thereto in the following manner, as represented in the drawings at Figs. 1, 2, 12, 13, 14, and 15.

The lathe *c* may be moved to and fro by cranks and connected rods, as is well understood, or it may be operated by cams, as has before been proposed. The reed *d*, instead of being fixed rigidly in the lathe, as has heretofore been usual, is shown fixed to a bar, *c'*, which has slides *c''* fixed thereto capable of sliding up and down on fixed guides *c'''*, formed on or fixed to the lathe-swords *c*. To the bar *c'* are fixed descending lugs or ears *c''*, which, by links or connecting-rods *c'''*, are connected to levers *c''''*, operated by cams *c'''''*, fixed to the cam-shaft *b*. Instead, however, of giving these motions to the reed only, a similar motion may be imparted to the entire lathe; but I prefer the plan above described.

x is a screw-bolt or set-screw to assist in the adjustment of the reed.

I have not shown or described the shuttle for inserting the ground-weft nor other well-known parts of the loom. They may be the same as are found in other looms, and I would remark that the ground-weft may be inserted by means of a weft-inserting needle or spear in the manner now well understood.

When weaving carpet with the loom constructed as above described, I prefer to use ground-warps of two sizes, the coarsest of which may, for distinction, be termed "body-warps," and the finer "binder-warps," each size of warps being passed through the eyes of the heddles of one of the heddle-frames, and there being two binder-warp threads for every body-warp thread. The catcher-warp threads are by preference finer than the binder-warp threads, and are passed through the eyes of the series of needles.

The various movements of the loom will take place in the order adopted when weaving by hand—that is to say, the following movements will be made in one revolution of the main shaft of the loom.

First, two or four shoots of ground-weft will be put across, as the case may be. This can be done either by the shuttle or by a weft-inserting needle or spear, the ground-warps being raised and depressed by the movement of their heddle-frames by their respective cams, in the ordinary manner for plain weaving, and the weft being driven up to the fell of the fabric by the lathe, in the usual manner.

Second, the loom being in position with the catcher-warp raised and the body and binder warps level, the traveling finger is moved across from right to left, thus introducing the

chenille or fur in the catcher-warp shed. The catcher-warp needles are moved down about one-fourth of their full movement. Then all the said devices remain at rest or dwell for some seconds to give the weaver time to regulate the fur or chenille in the shed, after which the catcher-warp needles are moved down about one-half of the remaining distance.

Third, the lathe is moved forward, the reed sliding down, so that the projections at the top press against the fur.

Fourth, as the reed presses the fur against the fell of the cloth it rises, and at the same time the catcher-warp needles complete their downward motion. While one of the heddle-frames carrying binder-warp rises and the other heddle-frame carrying body-warp descends to form the shed, the lathe is moved backward and the shuttle is thrown from right to left. Subsequently the lathe is moved forward and the shed is changed by the movements of the heddles and needles, the body and catcher warps being raised, and the binder-warp being depressed, the reed being raised so as to keep above all the warps. Afterward the lathe is again moved back, and the shuttle is thrown from left to right. The lathe is then moved forward, the catcher-warp needles are raised to their highest positions, and the body and binder warps are brought level by the movements of their respective heddles. The lathe also is moved backward.

Fifth, the above operations, commencing with "second," are repeated, the fur-finger being moved from left to right.

Having thus described a loom embodying my invention, I would have it understood that what I claim is—

1. The combination, substantially as before set forth, of the devices for controlling the ground-warps and catcher-warps, traversing the chenille weft, and driving the ground-weft and chenille weft to the fell of the fabric.

2. The combination, substantially as before set forth, of the row of catcher-warp needles, the traveling finger for the chenille, means for causing the finger to travel, and the two leaves of heddles for the ground-warp.

3. The combination, substantially as before set forth, of the two leaves of heddles for the ground-warp, the row of catcher-warp needles, the traveling finger for carrying the chenille, means for causing the finger to travel, and the lathe for beating up both the ground-weft and the chenille.

4. The combination, substantially as before set forth, of the row of needles for the catcher-warps, the traveling finger for the chenille, and the lay fitted with a reed having projections at its upper ends.

In witness whereof I have hereto set my hand this 16th day of August, A. D. 1883.

WILLIAM ADAM.

Witnesses:

JOHN TOMKINSON,
HENRY JAS. HOWFRAY.