

1

2

3 2

4

5 4

30 : 40 :

50 : 60 :

70 : Sc :

D1: Q1,Q2 :

C3 :

(' ') , N , N

1 (SRM) 3 La, Lb, Lc 가 (STATOR) A

가 가 (PHOTO) (Sa) 가

가 B (Sb) 가 (Q1)가 - 가 B 가 (Q2)가 -

, C (Q3)가 - C (Sc) 가 Lc 가

(Sa,Sb,Sc) (Q1 Q3)
 (Q4 Q9) - (R21 R23) (Q1 Q3)
 (Q4 Q9) 가 가
 (D2,D4,D6) , (Q1 Q3) (Q4 Q9) (Q4 Q9) (D3,D5,D7)

가 (10) 1 SMPS(20) 가 15V 40V
 가 (RPM) 가

가 N 가 N

3 ; 3 ; 1 ;
 2 ;
 /

A B '0' A B A
 (LOW)' (HIGH) ;

2 (L1) (C1) (D1)
 (C3) (30) ;
 (R2) ; 3 3 ;
 (Q1,Q2) ; (Q1,Q2)
 1 (D3) , (40) ; (Sc) 2
 (D2) ,

(50) , (50) ; (70)
(Q1,Q2) / (60) .
2 (SRM) (60) (60) (70)
1,2,3 (40) (Q2) (40) (60) (70)
, A (60) 1 (Q1) , (Q2)
(Q1) 가 (Q1) 가 A
(La) 가 (La) 가
, A (D2)(D3) .
B C , .
, A B 가 가
'0' , 3 2 A B ,
A B (60)
A B
' (LOW)' ' (HIGH)' (PWM)
, 4 2 (Sb) 가 ,
5 A B 가 C
A B C .
가 .
가 ,

(57)

1.

;

1

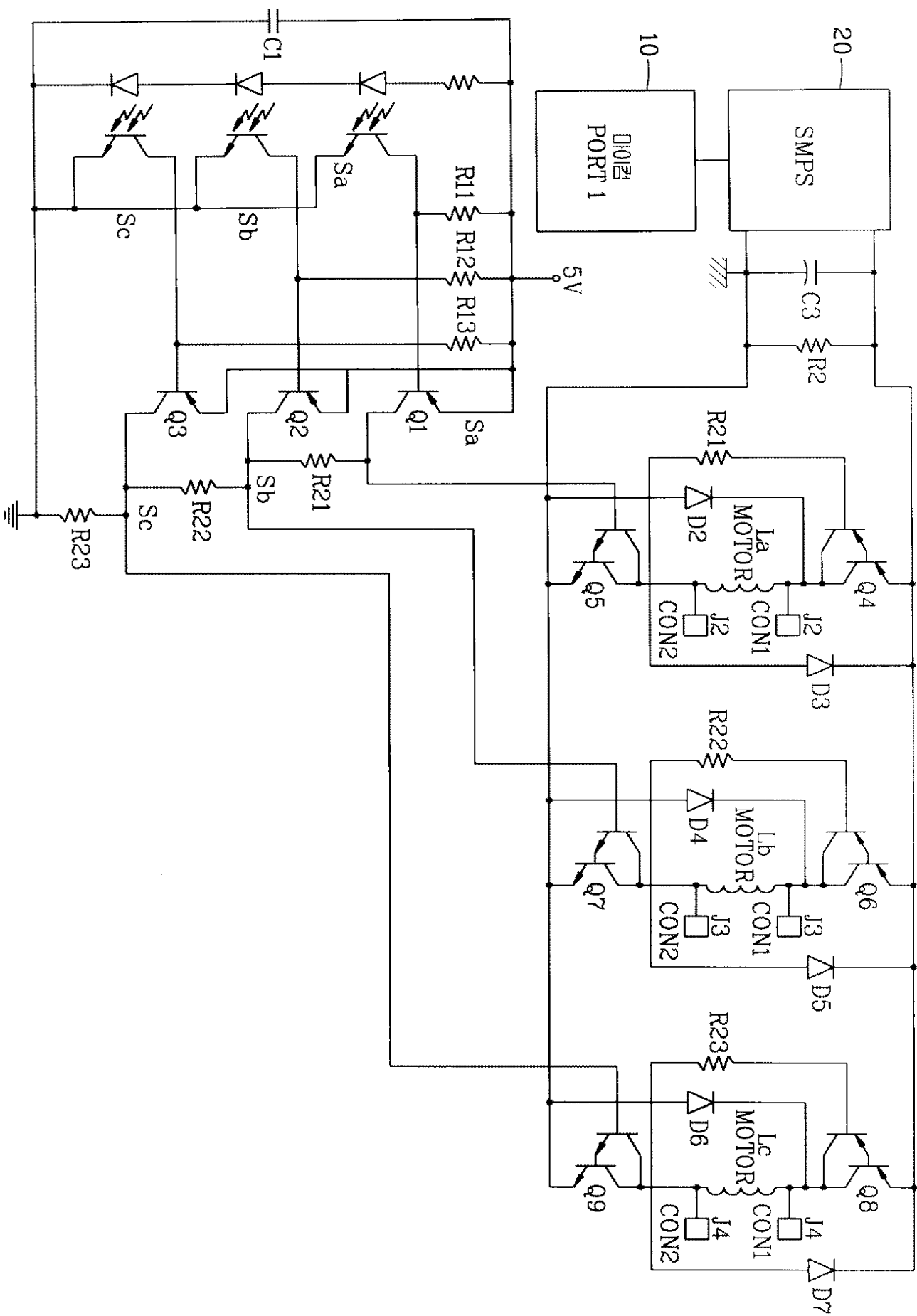

2

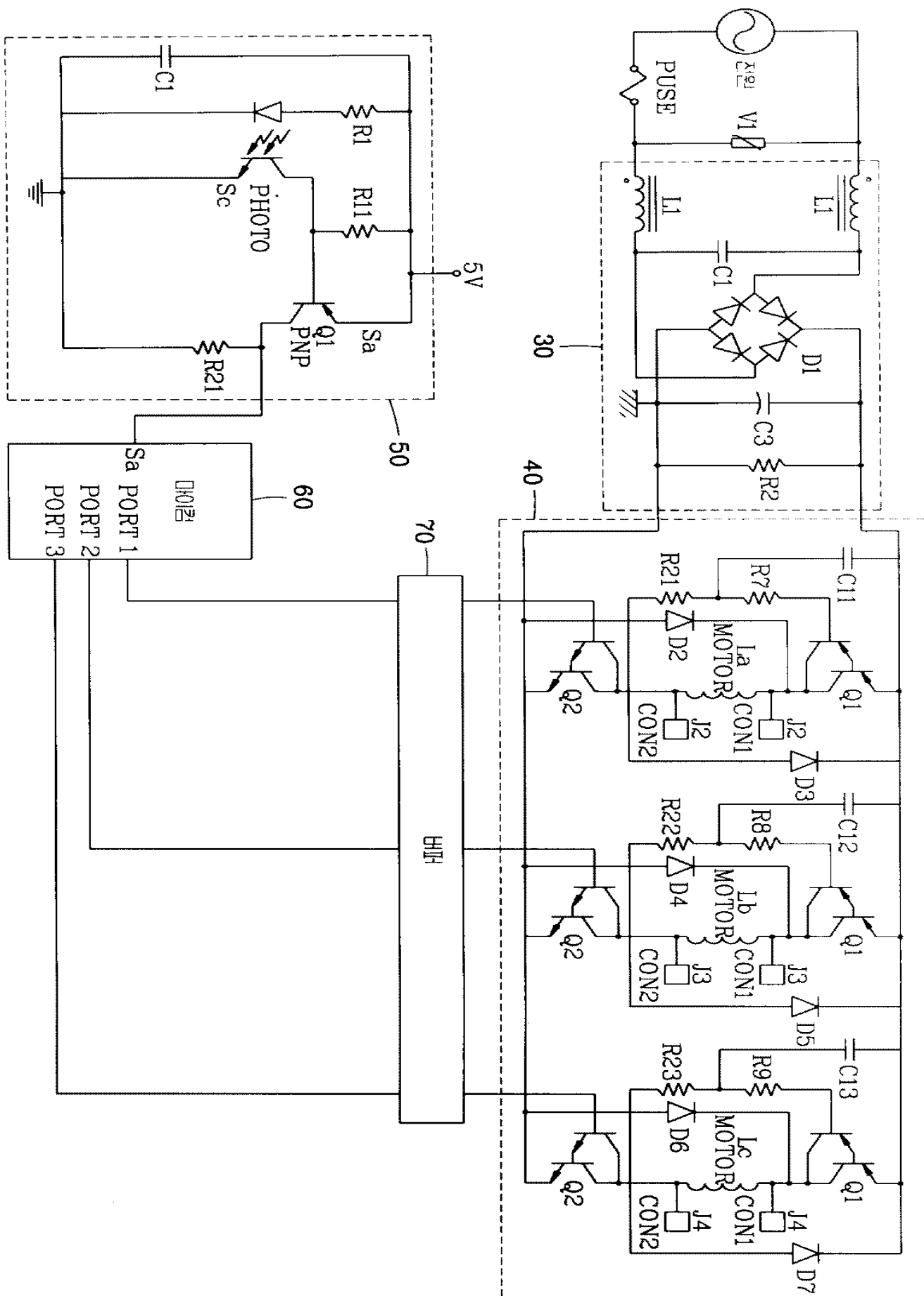

3

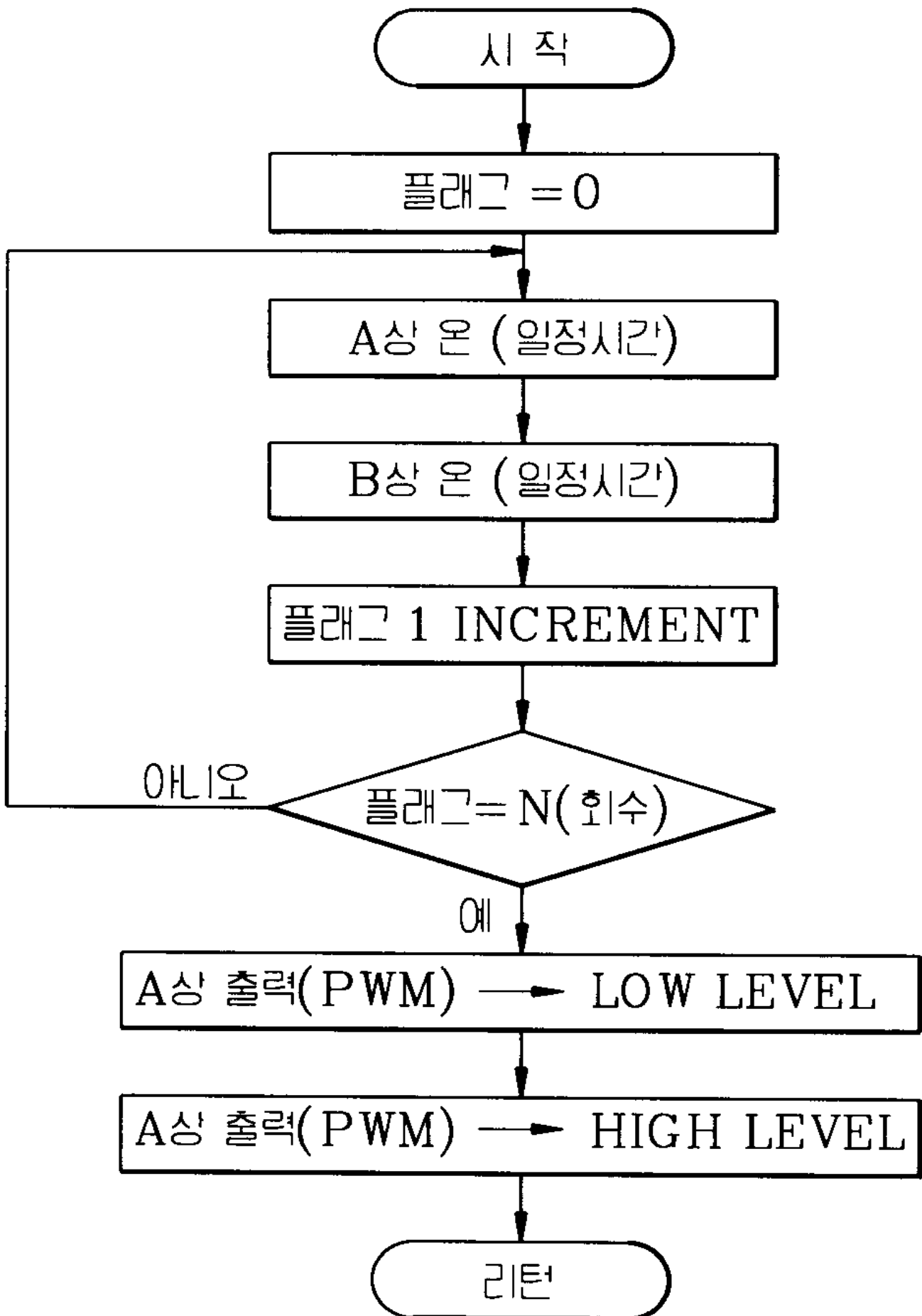

4

