

(19) World Intellectual Property Organization  
International Bureau



(43) International Publication Date  
5 July 2007 (05.07.2007)

PCT

(10) International Publication Number  
**WO 2007/073928 A1**

- (51) International Patent Classification:  
*H04M 15/00* (2006.01) *H04Q 3/00* (2006.01)
- (21) International Application Number:  
PCT/EP2006/012469
- (22) International Filing Date:  
22 December 2006 (22.12.2006)
- (25) Filing Language: English
- (26) Publication Language: English
- (30) Priority Data:  
05078004.8 27 December 2005 (27.12.2005) EP
- (71) Applicant (for all designated States except US): **KONINKLIJKE KPN N.V.** [NL/NL]; Maanplein 5, NL-2516 CK The Hague (NL).

AT, AU, AZ, BA, BB, BG, BR, BW, BY, BZ, CA, CH, CN, CO, CR, CU, CZ, DE, DK, DM, DZ, EC, EE, EG, ES, FI, GB, GD, GE, GH, GM, GT, HN, HR, HU, ID, IL, IN, IS, JP, KE, KG, KM, KN, KP, KR, KZ, LA, LC, LK, LR, LS, LT, LU, LV, LY, MA, MD, MG, MK, MN, MW, MX, MY, MZ, NA, NG, NI, NO, NZ, OM, PG, PH, PL, PT, RO, RS, RU, SC, SD, SE, SG, SK, SL, SM, SV, SY, TJ, TM, TN, TR, TT, TZ, UA, UG, US, UZ, VC, VN, ZA, ZM, ZW.

(84) Designated States (unless otherwise indicated, for every kind of regional protection available): ARIPO (BW, GH, GM, KE, LS, MW, MZ, NA, SD, SL, SZ, TZ, UG, ZM, ZW), Eurasian (AM, AZ, BY, KG, KZ, MD, RU, TJ, TM), European (AT, BE, BG, CH, CY, CZ, DE, DK, EE, ES, FI, FR, GB, GR, HU, IE, IS, IT, LT, LU, LV, MC, NL, PL, PT, RO, SE, SI, SK, TR), OAPI (BF, BJ, CF, CG, CI, CM, GA, GN, GQ, GW, ML, MR, NE, SN, TD, TG).

- (72) Inventor; and
- (75) Inventor/Applicant (for US only): **SCHÖPPER, Jörg** [DE/DE]; p/o E-Plus Platz 1, 40468 Düsseldorf (DE).
- (74) Agent: **WUYTS, Koenraad, Maria**; Koninklijke KPN N.V., P.O. Box 95321, NL-2509 CH The Hague (NL).
- (81) Designated States (unless otherwise indicated, for every kind of national protection available): AE, AG, AL, AM,

**Declaration under Rule 4.17:**  
— of inventorship (Rule 4.17(iv))

**Published:**  
— with international search report

For two-letter codes and other abbreviations, refer to the "Guidance Notes on Codes and Abbreviations" appearing at the beginning of each regular issue of the PCT Gazette.

(54) Title: INTELLIGENT NETWORK FOR ADMINISTRATING PREMIUM RATE CALLS

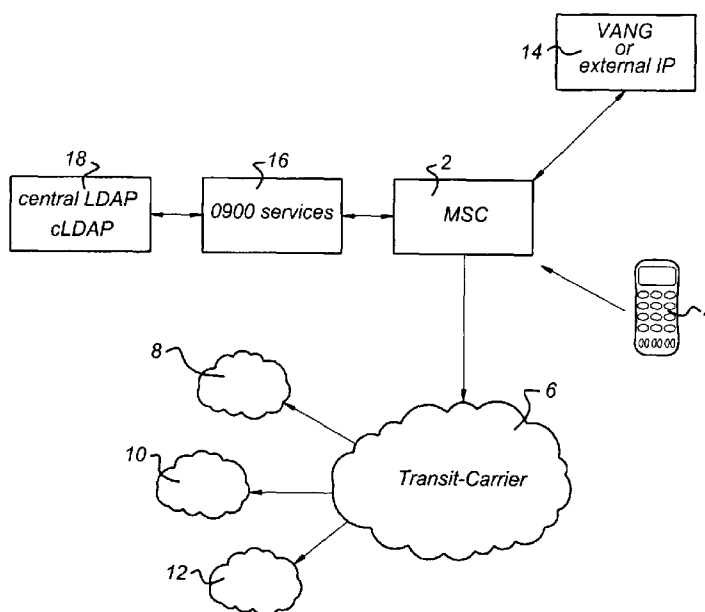

(57) Abstract: The invention relates to an Intelligent Network (16) arranged to communicate with a mobile switching center of a mobile communication network. The Intelligent Network is arranged to: receive a call message from said mobile switching center (2) comprising a calling party number and a called party number; retrieve a routing label and a tariff cluster number from a first database (28) using said called party number; modify said called party number by adding said routing label and said tariff cluster number as a prefix to said called party number to render a modified called party number; send a routing message to said mobile switching center (2) comprising said modified called party number.

WO 2007/073928 A1

## Intelligent network for administrating premium rate calls

### FIELD

5           The present invention relates to telecommunication networks, and more specifically to administrating premium rate calls in such a network.

### BACKGROUND

          Previously in Germany, premium rate numbers, such as the 0190-numbers, were construed so  
10   that a calling party could directly derive the tariff out of the number concerned. Due to governmental  
legislations, a new type of number regime has to be introduced in Germany. In this new system, the  
0190 numbers will be replaced by 0900 Premium service numbers. In the 0900 numbers, the tariff  
information is not located in the number range any more like for the 0190 numbers. The 0900 numbers  
will be classified by content. This means that for example information services start with 0900-1,  
15   leisure service start with 0900-3, adult services start with 0900-5 and diallers start with 0900-9.  
Furthermore, each individual premium rate service (PRS) number may be assigned its own tariff.  
Present Mobile Switching centres are not equipped to process the 0900 numbers. Modifying the  
MSCs concerned in a mobile telecom network will be very costly and time consuming.

### 20   SUMMARY

          It is desirable to provide a method of administrating tariff information for premium service  
numbers wherein the tariff information is not located in the number range any more, and without the  
need for substantial adjustment of the MSCs present in a mobile telecom network.

          The invention therefore relates to an Intelligent Network arranged to communicate with a  
25   mobile switching center of a mobile communication network, the Intelligent Network being arranged  
to:

- receive a call message from the mobile switching center comprising a calling party number and a  
called party number;
- retrieve a routing label and a tariff cluster number from a first database using the called party number;
- 30   - modify the called party number by adding the routing label and the tariff cluster number as a prefix to  
the called party number to render a modified called party number;
- send a routing message to the mobile switching center comprising the modified called party number.

The invention also relates to a mobile communication network comprising an Intelligent Network as described above.

In another aspect, the invention relates to method of administrating a call message from a mobile switching center of a mobile communication network, comprising:

- 5 - receive a call message from the mobile switching center comprising a calling party number and a called party number;
- retrieve a routing label and a tariff cluster number from a first database using the called party number;
- modify the called party number by adding the routing label and the tariff cluster number as a prefix to the called party number to render a modified called party number;
- 10 - send a routing message to the mobile switching center comprising the modified called party number.

#### BRIEF DESCRIPTION OF THE DRAWINGS

Embodiments of the invention will now be described, by way of example only, with reference to the accompanying schematic drawings in which corresponding reference symbols indicate

- 15 corresponding parts, and in which:
  - Figure 1 diagrammatically shows a part of a mobile telecommunication network in which an embodiment of the invention is incorporated;
  - Figure 2 shows a block diagram of part of the architecture of the network according to an embodiment;
  - 20 - Figure 3 shows a principle scheme of a record in the database 26 for a subscriber;
  - Figure 4 illustrates a sequence of announcements which may be generated by the 0900 service module;
  - Figure 5 shows a flow chart of actions taken by the 0900 service module 16 according to an embodiment of the invention;
  - 25 - Figure 6 schematically depicts a part of the billing structure of the telecom network;
  - Figure 7 schematically shows the IN service module 16 together with the database it receives information from.

#### DETAILED DESCRIPTION

- 30 Figure 1 diagrammatically shows a part of a mobile telecommunication network in which an embodiment of the invention is incorporated. A state of the art Mobile Switching Centre 2, also referred to as MSC 2, is arranged to switch calls from a mobile telephone 4, to a state of the art

transit-carrier network 6. The transit-carrier network 6 will pass the calls to other service provider networks 8, 10, 12. The MSC 2 also communicates with a VANG 14 which is arranged to produce announcements for the price of a call. The announcements are sent to the mobile telephone 4 before the actual connection is made.

5 According to the invention, an Intelligent Network 16 is arranged to communicate with the MSC 2 in order to process premium rate service number calls. The MSC 2 is arranged to receive a call message from the MSC 2. The call message comprises both a number of the calling party, i.e. the calling party number, and a number of a called party, i.e. the called party number. In an embodiment, the Intelligent Network 16 will only receive a call message from the MSC 2 if the calling party calls a 0900 service  
10 number. Therefore, the Intelligent network 16 is also referred to as the 0900 service module. It should be noted that the 0900 service number is just an example and other numbers may be used to invoke the Intelligent network 16. The 0900 service module 16 is arranged to access a central database 18 for retrieving e.g. subscriber data of the subscriber calling with the mobile telephone 4. According to an embodiment, the 0900 service module 16 is also arranged to modify the called party number and send  
15 the modified called party number to the MSC 2. the modification of the called party number is explained in more detail below.

Figure 2 shows a block diagram of part of the architecture of the network according to an embodiment. For the administration of the PRS numbers the new 0900 service is arranged next to already existing VPN 20 and a Post-Paid IN service 22. In this embodiment, the system architecture  
20 contains a database for subscriber info 26 and another database for tariff information 28. In an embodiment, both databases 26, 28 comprise real-time databases such as LDAP. Both LDAP databases 26, 28 may be provided and administrated by a service provider of the premium rate service. The exact implementation of these databases 26, 28 is not relevant for the invention, and will not be discussed here. In an embodiment, the new 0900 service module 16 is also arranged to support the  
25 addressing of announcements in the MSC 2 or an external IP 24.

In an embodiment, the tariff information depends on one or more subscriber parameters and one or more provider parameters provided by the service provider of 0900 numbers. Subscriber parameters are for example:

- 30
- the type of subscriber (Pre or Post-Paid),
  - the name of the Independent Service Provider (ISP) of the subscriber.

In an embodiment, the service provider parameters comprise a so-called ‘tariff cluster’ which is a classification number used for classifying the possible PRS numbers into several clusters (i.e. sets) each having a unique tariff cluster number. A service provider may provide its 0900 number(s), corresponding routing information and a corresponding tariff cluster. The tariff cluster may for example be an index with 2 digits. This provides the possibility to address 100 different tariff clusters from 00 to 99.

In an embodiment, the following parameters are taken into account for the processing of a 0900 number and shall be administrated in the 0900 service module 16:

- service ID,
- 10 - tariff cluster,
- type of subscriber and
- ISP.

Table 1 illustrates a possible solution for the administration of the these parameters.

15 Table 1

service ID	tariff cluster	Pre/PostPaid	ISP	price/min	price/call
900	00	PostPaid	E-Plus	19	0
900	00	PrePaid	E-Plus	20	0
900	01	PostPaid	E-Plus	19	100
:	:	:	:	:	:
900	99	PrePaid	E-Plus	159	1500
900	00	PostPaid	Debitel	19	10
:	:	:	:	:	:
900	99	PrePaid	Talkline	19	0

In table 1 a price per minute and a price per call for every tariff cluster is defined depending on the type of subscriber (Pre/Post-Paid) and the customer’s ISP. For every ISP 100 different tariff clusters are possible, i.e. 00-99. If for example a service provider administrates 15 ISPs, the maximum

possible number of 0900 number entries in table 1 is  $100 \times 15 \times 2 = 3000$ .

It is noted that the size of the table 1 is not restricted. Every field in this table may be handled flexible to add, to delete or to modify the content. Furthermore, the configuration of tariff cluster, Pre/Post-Paid, ISP and prices is not restricted to only the service (index) 900. The parameters price per minute and price per call are relevant for the announcements before connecting the call to the service provider as will be explained later on.

The 0900 service module 16 may also provide an interface to insert or extract (up- and download) all data of table 1 in a text file (bulk file). A new or an update of a tariff cluster in table 1 can be administrated in a timetable. The timetable may be administrated offline in the 0900 service module 16 itself. Depending of the configured date the 0900 service will then update in table 1 the price per minute and price per call. The 0900 service module 16 may for example check once per day if an update is necessary. It is also possible to load an update immediately into table 1. Any modification may be reported in a log file. An example of such an update table is illustrated by table 2.

15 Table 2

Service	tariff cluster	Pre/Postpaid	ISP	Price/min	Price/Call	Valid from	Valid to
0900	00	Postpaid	E-Plus	19	0	01.01.2005	31.06.2005
0900	00	Postpaid	E-Plus	20	5	01.07.2005	31.12.2005

The 0900 service module 16 ensures the update of a price . In case of failure the 0900 service module 16 may inform an administrator of the service provider concerned. Before a tariff model of a tariff cluster expires, the 0900 service module 16 may inform (e.g. warning) the administrator. The time when the warning is generated may be configurable in the 0900 service.

Depending on the ISP it may also be possible to configure a maximum price per minute and/or price per call. In case of an update for the data in table 1, the 0900 service module 16 will then first verify the new data with the configured maximum parameters. The verification could take place in the user GUI environment of a control server.

According to an embodiment, the 0900 service module 16 is arranged to access the database 28 for tariff and routing information. The database 28 for tariff and routing information may contain all kinds of 0900 numbers supported by a particular ISP. Next to the PRS numbers the table may contain a label for routing e.g. CIC, the tariff cluster number and the type of bearer service. The routing label may be a configurable parameter and need not be a fixed value. Table 3 illustrates a possible configuration.

service	premium rate service number	routing label	tariff cluster	bearer service
900	49900123456	C1C	00	speech
900	4990078901	C1C	03	fax
900	499003777888	BT3	11	data
:	:	:	:	:

Table 3

5

Every PRS number will be described by the service identifier, e.g. 900. The 0900 service need not be restricted to handle only numbers described with the identifier 900.

The length of a PRS number may be variable. But the PRS numbers with the same content number (digit) can be conform. The tables below describes examples of the number length depending of the content number.

10

prefix 900	content number [1, 3, 5]	number
3	1	6

Table 4: Number length with the content number 1, 3 or 5

prefix 900	content number [9]	number
3	1	7

Table 5: Number length with the content number 9

15

The parameter bearer service in table 3 contains only the option for the service speech, fax and data, but other bearer type are possible. The 0900 service module may be arranged to verify the bearer configuration in table 2 with the data in an INAP IDP message.

Depending on a timeframe a service provider has the permission to change the configuration

of the tariff cluster for his premium rate service number(s). This modification causes another price model for the 0900 number and has to be recognized by the 0900 service .

The parameter routing label and tariff cluster are forwarded in the called party number to the transit carrier network independent of the type of subscriber (Pre or PostPaid). The 0900 service module 16 is arranged to modify the called party number. A possible modification of the called party number is an extension of the called party number with a prefix wherein the prefix consists of the routing label e.g. C1C (always 3 digits) and the tariff cluster e.g. 22 (always 2 digits). If a premium rate number has the format: 900 xxx and TON = national, then the modified called party number looks like e.g. C1C22 900 xxx, with TON = national.

In an embodiment, the 0900 service module 16 is arranged to access the database 26 for subscriber data. The 0900 service module 16 is arranged to evaluate whether a number can be routed to the destination or if it is marked as a so-called screened number. This information may be located in the database 26. Every profile of a Pre- or PostPaid subscriber in the database 26 provides the possibility to configure screening services of premium rate services. A correlation of more than one service number is possible.

Figure 3 shows a principle scheme of a record in the database 26 for a subscriber with the MSISDN 491774481234. The subscriber has configured a screening for the services 1 and 2. To identify the corresponding premium rate number the 0900 service module 16 may administrate a mapping table e.g. see table 6 for an example.

Screening index	service number	Announcement ID
1	9001	42
2	9002	42
3	9003	42
:	:	:
10	900	152
:	:	:

table 6

Table 6 shows a mapping between screening index and premium rate service number. If a



subscriber profile describes a screening for a 0900 number, the 0900 service module 16 will inform the subscriber with an announcement regarding this restriction. The related announcement ID shall be administrated also in table 6. Afterwards the 0900 service module 16 will release the call.

5 In an embodiment, the 0900 service module 16 is arranged to compare the called party number in an INAP IDP message with the service number in table 6 using a longest match operation. The number of digits for a service number shall for example be 24 digits. The number of entries in table 6 is not restricted.

10 In an embodiment, the 0900 service module 16 is arranged to initiate an announcement for the price per minute and price per call before connecting. The announcement itself is produced a the VANG 14. Before connecting the call to the service provider concerned, the subscriber shall be informed about the price of the call. The announcement shall may consist of the following information:

- price per minute,
- price per call.

15

The 0900 service module will invoke the announcements. The required information of price per minute and price per call are described in table 1. E.g. the tariff cluster 01 for PostPaid subscribers of the ISP E-Plus requires the following announcements (examples):

20 “The price per minute for this call is 19 Cent”, or  
“The price per call is 1 Euro”.

25 The 0900 service module 16 may be arranged to ensure the right price announcements. E.g. if a price per minute is 159 cent, then the subscriber must hear the announcement “1 Euro and 59 cent”. The 0900 service module 16 may generate first the announcement price per minute and afterwards price per call. Before connecting the call a gap of for example 3 seconds after the price announcement(s) may be provided to the subscriber to provide her the possibility to refuse the call. In case the call will be refused, the subscriber shall be not charged. The gap of 3 seconds silence may be also generated by an announcement. The gap (like a UNIX sleep operation) may as well be configurable in the 0900 service module 16. Preferably, the unit to configure the sleep shall be  
30 milliseconds (ms). The gap may be handled as an add on to the announcement behind the 'price' announcements.

In an embodiment, further scenarios are also covered by the 0900 service module 16. These

scenarios comprise:

- The 0900 number is not reachable,
- The 0900 service is currently not reachable.

5 Depending of the bearer service (see table 3) the 0900 service may provide the possibility to configure a voice, text (USSD) announcement or no announcement, e.g. no announcement for non-speech services. The 0900 service module 16 may be arranged to support to address the announcements in the MSC 2 (or VANG 14) or an external IP 14. Possible faulty scenarios which requires an announcements are (example of announcements):

- 10 -LDAP database is not reachable -> "The 0900 service is currently not reachable"
- 0900 service number is blocked by the subscriber -> "The 0900 number is not reachable on customer demand".
- 0900 number is not provided in table 3 -> "The 0900 number is not reachable"
- Internal error, e.g. mapping of tariff cluster in table 1 and 2 does not match -> "The 0900  
15 number is not reachable"
- External IP is not reachable -> Call will be released by the 0900 service.

In an embodiment, before the announcement of price per minute and after the announcement of price per call the 0900 service module 16 provides the option to play additional announcements.  
20 One before and one after. The corresponding IDs shall be administrated in the table mentioned above. In case the announcements do not contain an ID no announcements has to be generated (in this case no INAP play\_announcement message is necessary). The announcements IDs may be administrated in a separate table in the 0900 service module 16, see table 7. All parameters of this table may be configurable. If one parameter „price per minute“ or „price per call“ is zero(0) in table 1, then no  
25 announcement will be generated or invoked by the 0900 service module 16. This means no INAP play\_announcement message will be generated. In table 7 the announcements (2) and (3) exist out of an fix and a variable part. The variable part announces the amount/price described in table 1.

Service	Pre-announcement (1)	Price per minute (2)	Price per Call (3)	Post-announcement (4)	play list
0900	420	0	300	200	1, 3, 4
0900	420	250	0	200	1, 2, 4
0900	0	250	300	0	2, 3
0900	420	250	300	200	1, 2, 3, 4

Table 7

Figure 4 illustrates a sequence of announcements which may be generated by the 0900 service module 16. In case of four announcements there are 16 different scenarios possible. The announcement after the announcements 'price per minute' and 'price per call' contains e.g. the gap of 3 second.

Figure 5 shows a flow chart of actions taken by the 0900 service module 16 according to an embodiment of the invention. The 0900 service module 16 cooperates with the already existing IN PrePaid 20 and VPN services 20, see figure 2. In a first step 51, the 0900 service module 16 is invoked by the MSC 2 in case a mobile subscriber (i.e. calling party) calls a 0900 called party number. In a step 52, the 0900 service module 16 accesses the database 26 to find for a specific calling party number, e.g. +491774481234, the type of the subscriber, the ISP and the screening information for that calling party number. In case the specific 0900 number is marked as 'screened', the 0900 service module will play or invoke an announcement, see step 54 and will release the call afterwards, see step 55. This will end the procedure at step 56. If the called party is not marked as screened, step 53 is followed by a step 57 in which a second database 28 is accessed to determine the routing label, tariff cluster and possibly the bearer service for the specific 0900 number (i.e. the called party number). In case the 0900 called party number does not exist in the database 28, see step 58, the 0900 service module 16 will play or invoke an announcement (step 54) and to release the call afterwards (step 55). In case of no restriction for the 0900 number (called party) the 0900 service module 16 will analyze the tariff cluster, routing label and the bearer service, see step 59. Depending on the tariff cluster, the type of subscriber and the ISP the 0900 service module 16 will initiate an announcement with the information of price per minute and price per call of the 0900 number (called party), see step 60. Next in a step 61, the 0900 number (called party) is modified by way of putting a prefix containing the routing label (e.g. C1C) and the tariff cluster in front of the called party number. Then, the 0900 service ends at step 56.

The 0900 service module ensures the correct billing of all 0900 numbers for the subscribers. A distinction is made between Post- or Prepaid subscribers. For both types of subscribers a different accounting is required. Due to the specific arrangement of the 0900 service module 16, the introduction of the 0900 service requires no modifications in the existing IN Pre and PostPaid (VPN) services. Except for the tariff data for the PrePaid service.

Figure 6 schematically depicts a part of the billing structure of the telecom network in which the 0900 service module 16 according to an embodiment is implemented. The MSC 2 forwards the

modified called party number, also referred to as modified B-number, to a mediation device 70. The mediation device 70 may be a state of the art mediation device which needs adjustment in order to process the modified B-numbers. The mediation device 70 is arranged to communicate with a ICB 72. Furthermore, the mediation device 70 is arranged to communicate with a CASS system 74 that is  
5 connected to a BSCS 76 in order to pass for example so-called 'tariff classes'. The new mediation device 70 is arranged to administer a table called the tariff class table 78. In the tariff class table 78, specific tariff classes are related to the specific routing prefixes and a specific tariff cluster. In the example shown in figure 6, the tariff class 1000 is related to the routing prefix "C1C" and the tariff cluster "00". This means that a call to a called number "C1C00xxxxxxx" will be billed by the BSCS  
10 using the tariff class "1000".

Figure 7 schematically shows the IN service module 16 together with the database it receives information from. As was explained above, the IN service module 16 is arranged to access one or more central databases 18 for retrieving subscriber data and ISP and tariff data. The central database 18 is receiving input from an internal database server 80, such as a CASS or an inventory server 80.  
15 This internal database server 80 receives input from an external 0900 database 82. The external database 82 may be a database managed by an other ISP and stores data such as the available 0900 PRS numbers of a specific ISP, the associated tariff clusters, the routing prefixes (such as "C1C"), and the bearer service type. (Voice, Data, Fax). The internal database server 80 will use the data received to generate a consolidated list with 0900 call numbers with the appropriate tariff clusters and routing  
20 prefixes. This information will be presented to the central database 18 together with black list information (i.e. screening info). The internal database server 80 may be further arranged to generate a price list with the 0900 service numbers for Pre-/Postpaid and ISP dependent 0900 prices which may be requested from the side of EHB or the Internet. Also a price list in a PDF format may be produced by the internal database server 80.

25 Each ISP can provide its own "external database" 82 so as to provide the specific prices grouped into the specific tariff clusters. The tariff cluster information is published by the owner of the IN service module 16, so that the ISPs concerned can deliver their specific PRS prices.

While specific embodiments of the invention have been described above, it will be appreciated that the invention may be practiced otherwise than as described. For example, the IN service module  
30 16 may comprise a plurality of devices. The descriptions above are intended to be illustrative, not limiting. Thus, it will be apparent to one skilled in the art that modifications may be made to the invention as described without departing from the scope of the claims set out below.

**CLAIMS**

1. Intelligent Network (16) arranged to communicate with a mobile switching center of a mobile communication network, said Intelligent Network being arranged to:
  - 5 - receive a call message from said mobile switching center (2) comprising a calling party number and a called party number;
  - retrieve a routing label and a tariff cluster number from a first database (28) using said called party number;
  - modify said called party number by adding said routing label and said tariff cluster number as a  
10 prefix to said called party number to render a modified called party number;
  - send a routing message to said mobile switching center (2) comprising said modified called party number.
  
2. Intelligent Network according to claim 1, wherein said Intelligent Network is arranged to:
  - 15 - retrieve price information from a table comprising possible tariff cluster and corresponding prices,
  - invoke a play announcement comprising a voice message for a price of a call.
  
3. Intelligent Network according to any of the preceding claims, wherein said Intelligent Network is arranged to:
  - 20 - retrieve screening information from a second database (26) using said calling party number;
  - release the call if said called party number is marked screened in the second database (26).
  
4. Intelligent Network according to any of the preceding claims, wherein said tariff cluster number comprises two digits.  
25
  
5. Intelligent Network according to any of the preceding claims, wherein said tariff cluster number determines a price of a group of PRS numbers.
  
6. Intelligent Network according to any of the preceding claims, wherein said PRS numbers  
30 provide access to 0900 services.
  
7. Mobile communication network comprising an Intelligent Network (16) according to any of the

preceding claims.

8. Method of administrating a call message from a mobile switching center of a mobile communication network, comprising:

- 5 - receive a call message from said mobile switching center (2) comprising a calling party number and a called party number;
- retrieve a routing label and a tariff cluster number from a first database (28) using said called party number;
- modify said called party number by adding said routing label and said tariff cluster number as a
- 10 prefix to said called party number to render a modified called party number;
- send a routing message to said mobile switching center (2) comprising said modified called party number.

15

\*\*\*\*\*

Fig 1

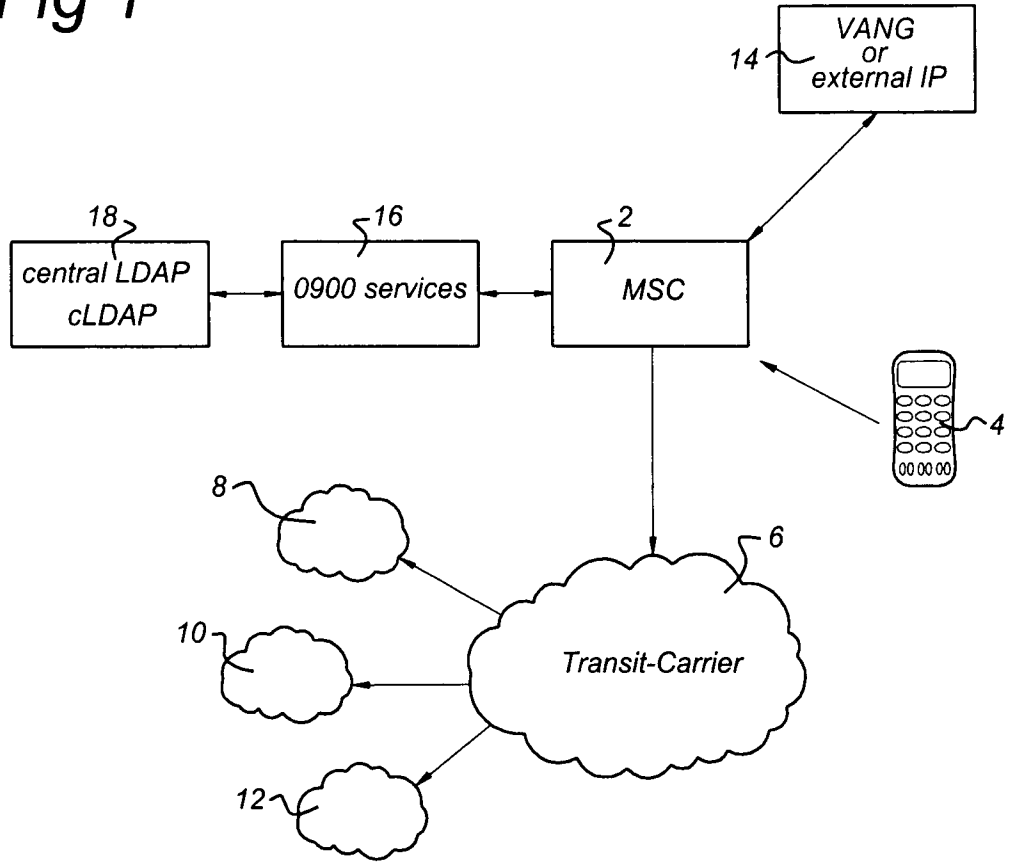
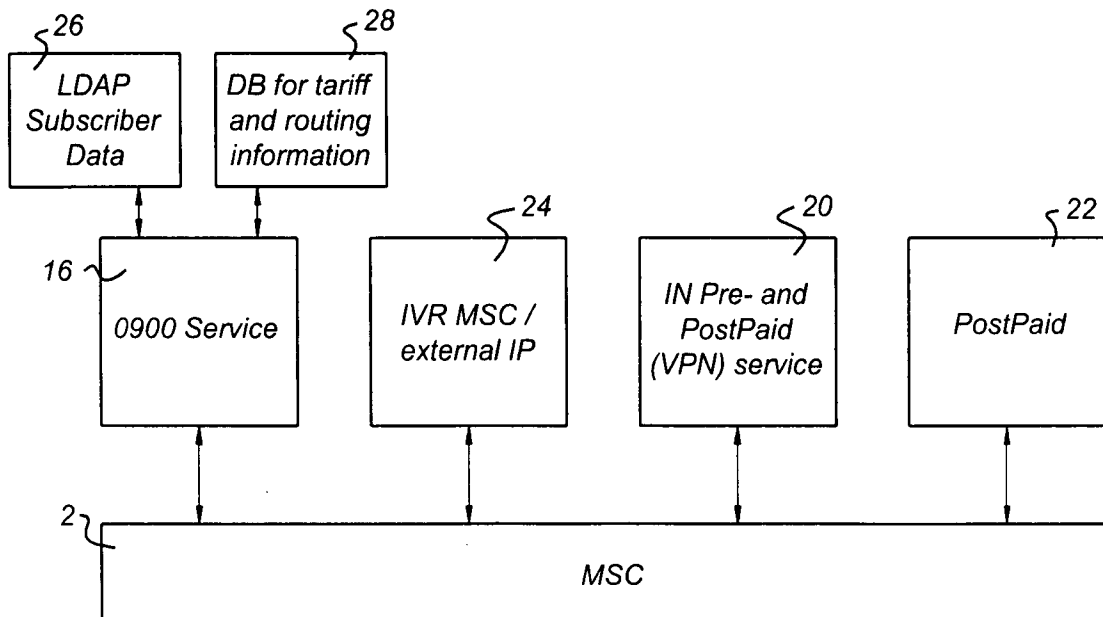
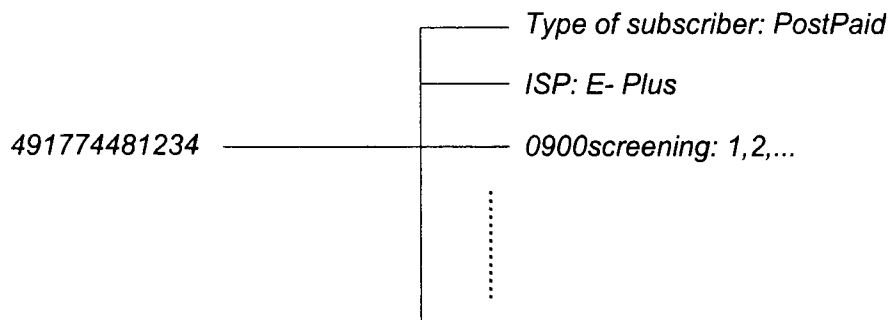

Fig 2



*Fig 3*



*Fig 4*

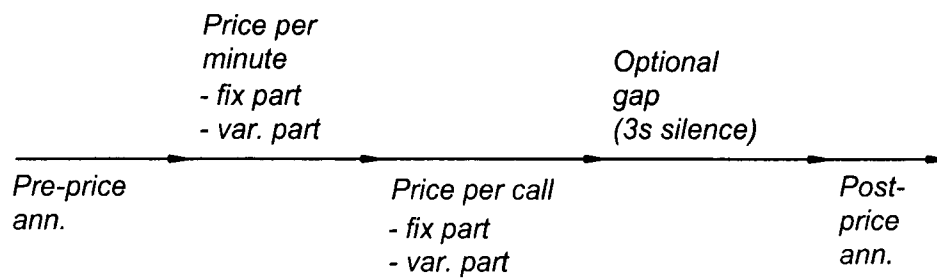



Fig 5

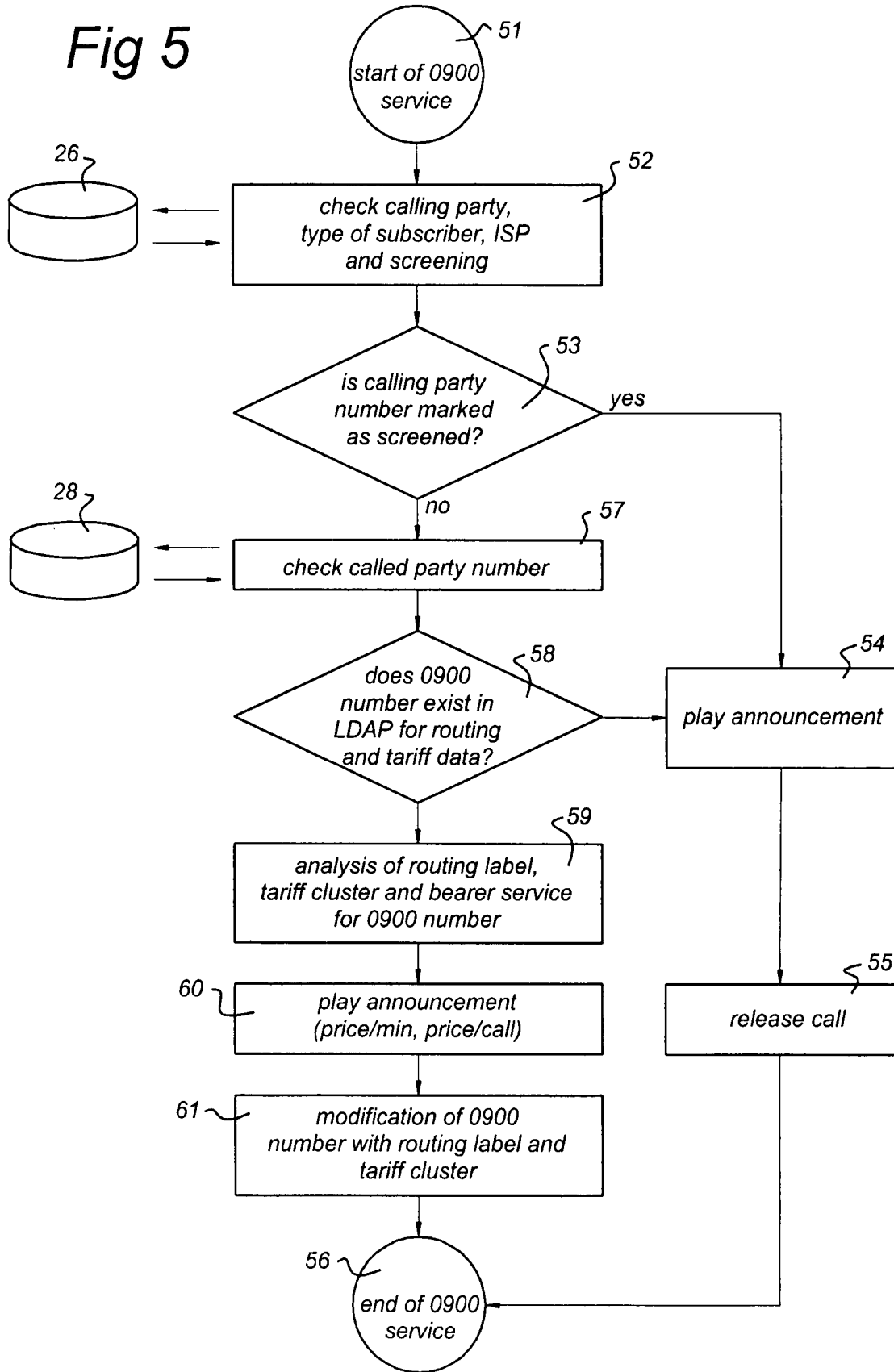

Fig 6

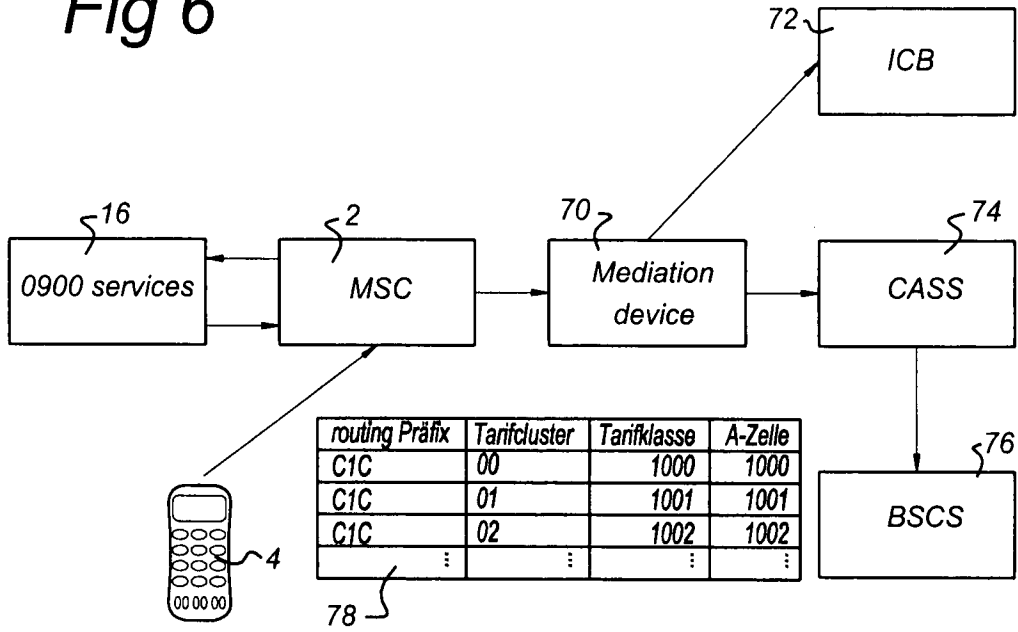
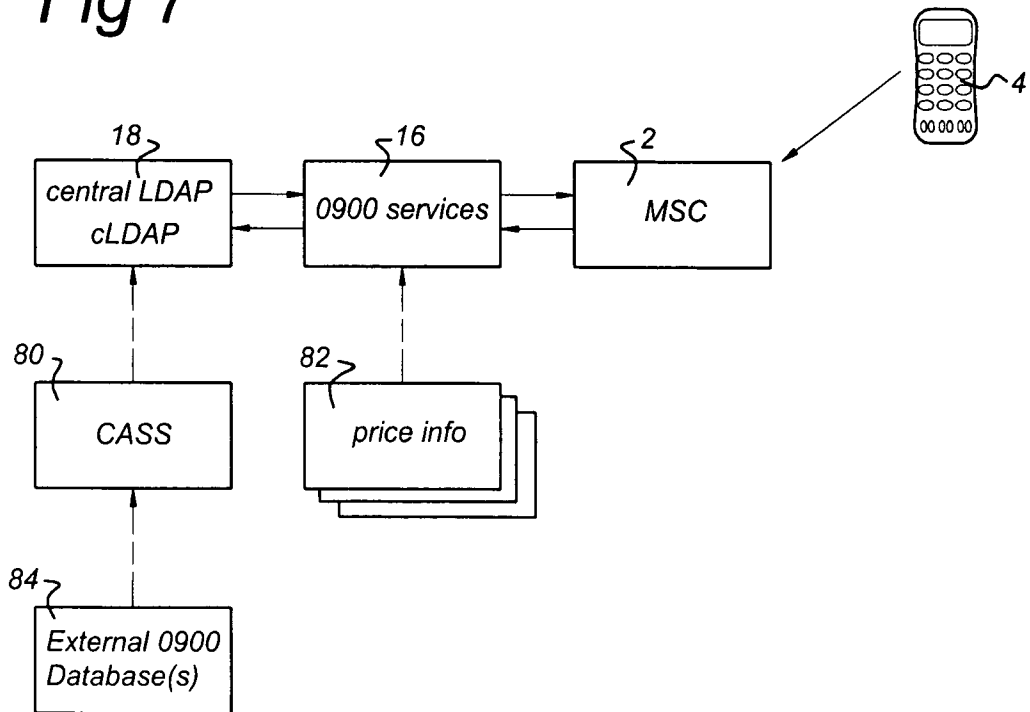

Fig 7



## INTERNATIONAL SEARCH REPORT

International application No  
PCT/EP2006/012469A. CLASSIFICATION OF SUBJECT MATTER  
INV. H04M15/00 H04Q3/00

According to International Patent Classification (IPC) or to both national classification and IPC

## B. FIELDS SEARCHED

Minimum documentation searched (classification system followed by classification symbols)  
H04M H04Q

Documentation searched other than minimum documentation to the extent that such documents are included in the fields searched

Electronic data base consulted during the international search (name of data base and, where practical, search terms used)

EPO-Internal, WPI Data, PAJ, INSPEC

## C. DOCUMENTS CONSIDERED TO BE RELEVANT

Category*	Citation of document, with indication, where appropriate, of the relevant passages	Relevant to claim No.
X	CA 2 519 807 A1 (T MOBILE DEUTSCHLAND GMBH [DE]) 30 September 2004 (2004-09-30) the whole document	1-8
X	WO 02/054786 A (NOKIA CORP [FI]; RATILAINEN RAUNO [FI]; KOEPOESDI PAL [HU]) 11 July 2002 (2002-07-11) page 1, line 25 - last line page 2, line 33 - page 3, line 9 page 4, line 15 - line 32 page 5, line 25 - last line page 6, line 12 - line 21 page 7, line 27 - last line page 8, line 28 - page 9, line 10	1-8
X	US 6 381 326 B1 (SALISBURY BRUCE FREDRICK [US]) 30 April 2002 (2002-04-30) the whole document	1-8

 Further documents are listed in the continuation of Box C. See patent family annex.

\* Special categories of cited documents :

- \*A\* document defining the general state of the art which is not considered to be of particular relevance
- \*E\* earlier document but published on or after the international filing date
- \*L\* document which may throw doubts on priority claim(s) or which is cited to establish the publication date of another citation or other special reason (as specified)
- \*O\* document referring to an oral disclosure, use, exhibition or other means
- \*P\* document published prior to the international filing date but later than the priority date claimed

- \*T\* later document published after the international filing date or priority date and not in conflict with the application but cited to understand the principle or theory underlying the invention
- \*X\* document of particular relevance; the claimed invention cannot be considered novel or cannot be considered to involve an inventive step when the document is taken alone
- \*Y\* document of particular relevance; the claimed invention cannot be considered to involve an inventive step when the document is combined with one or more other such documents, such combination being obvious to a person skilled in the art.
- \*Z\* document member of the same patent family

Date of the actual completion of the international search

27 March 2007

Date of mailing of the international search report

03/04/2007

Name and mailing address of the ISA/  
European Patent Office, P.B. 5818 Patentlaan 2  
NL - 2280 HV Rijswijk  
Tel. (+31-70) 340-2040, Tx. 31 651 epo nl,  
Fax: (+31-70) 340-3016

Authorized officer

Patlaka, Efi

## INTERNATIONAL SEARCH REPORT

International application No  
PCT/EP2006/012469

C(Continuation). DOCUMENTS CONSIDERED TO BE RELEVANT		
Category*	Citation of document, with indication, where appropriate, of the relevant passages	Relevant to claim No.
A	US 5 574 781 A (BLAZE MATTHEW A [US]) 12 November 1996 (1996-11-12) column 5, line 3 - column 6, line 21 -----	1-8
A	US 4 797 915 A (BOWKER DUANE O [US] ET AL) 10 January 1989 (1989-01-10) the whole document -----	1-8

## INTERNATIONAL SEARCH REPORT

Information on patent family members

International application No

PCT/EP2006/012469

Patent document cited in search report		Publication date	Patent family member(s)	Publication date
CA 2519807	A1	30-09-2004	AT 337687 T	15-09-2006
			CN 1762164 A	19-04-2006
			DE 10312049 A1	07-10-2004
			WO 2004084563 A1	30-09-2004
			EP 1604533 A1	14-12-2005
			US 2006276169 A1	07-12-2006
WO 02054786	A	11-07-2002	CA 2430879 A1	11-07-2002
			CN 1483291 A	17-03-2004
			FI 20002888 A	30-06-2002
			US 2004053604 A1	18-03-2004
US 6381326	B1	30-04-2002	NONE	
US 5574781	A	12-11-1996	CA 2156561 A1	09-06-1996
US 4797915	A	10-01-1989	CA 1281112 C	05-03-1991