

(No Model.)

2 Sheets—Sheet 1.

# H. G. WADLEY. LUMBER LOADING APPARATUS.

No. 561,631.

Patented June 9, 1896.

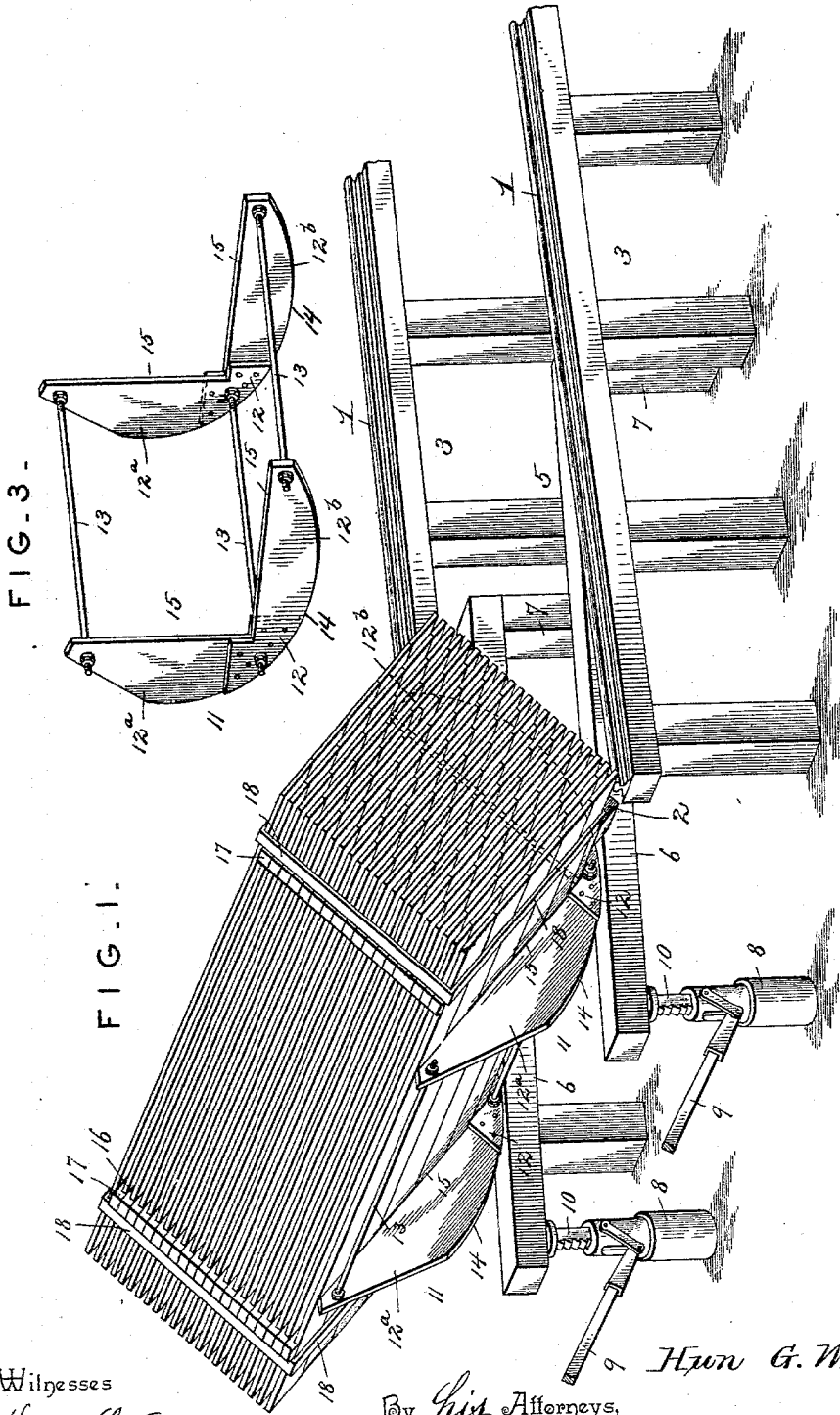

FIG. 3 -

FIG. 1.

Inventor

*Harry G. Wadley.*

By *his* Attorneys,

*C. Knowles.*

Witnesses

*Harry L. Amer*  
*[Signature]*

(No Model.)

2 Sheets—Sheet 2.

H. G. WADLEY.  
LUMBER LOADING APPARATUS.

No. 561,631.

Patented June 9, 1896.

FIG. 4.

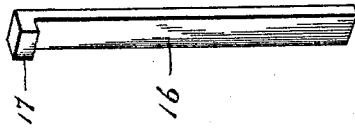
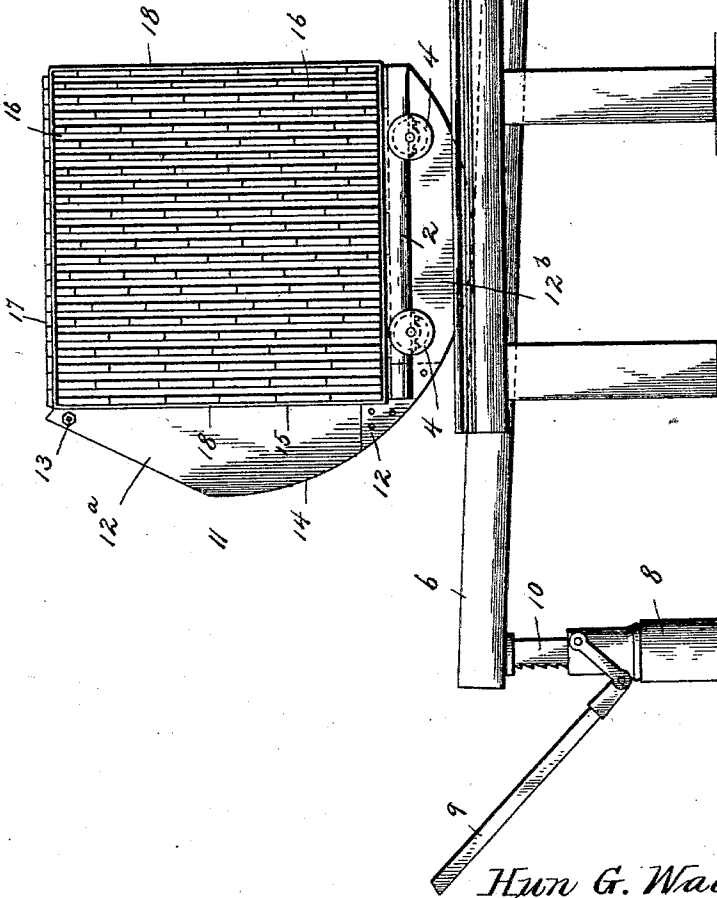

FIG. 2.



Inventor

*Harry G. Wadley.*

By his Attorneys,

*C. Snow & Co.*

Witnesses

*Harry L. Amer*  
*J. E. Hoyle*

# UNITED STATES PATENT OFFICE.

HUN G. WADLEY, OF WILMINGTON, NORTH CAROLINA.

## LUMBER-LOADING APPARATUS.

SPECIFICATION forming part of Letters Patent No. 561,631, dated June 9, 1896.

Application filed November 5, 1895. Serial No. 568,037. (No model.)

To all whom it may concern:

Be it known that I, HUN G. WADLEY, a citizen of the United States, residing at Wilmington, in the county of New Hanover and State of North Carolina, have invented a new and useful Lumber-Loading Apparatus, of which the following is a specification.

My invention relates to an apparatus for receiving and transporting lumber to a kiln or drier after leaving the mill; and it has for its object to simplify and improve the construction shown in my former patent, No. 506,286, granted October 10, 1893, by providing means which may be operated with facility for transferring the load from the inclined position in which it is formed to the upright position which it occupies while supported upon a truck, said means being such as to enable the transfer to the truck to be made without loss of time.

The essential feature of my invention resides in the use of a cradle which performs the additional function of a rest or former upon which the lumber is packed or piled, and by which, after the members of the pile have been bound together to prevent displacement, the load is transferred to the trucks, and the construction of this cradle is such as to maintain its bearing-point or point of contact with a suitable support in the vertical plane of the center of gravity of the load in all positions, whereby the effort necessary to move the cradle with its load from one position to another does not involve moving the load against the force of gravity.

Further objects and advantages of this invention will appear in the following description, and the novel features thereof will be particularly pointed out in the appended claims.

In the drawings, Figure 1 is a perspective view of a loading apparatus constructed in accordance with my invention, the parts being shown in the positions which they occupy during the loading of the cradle. Fig. 2 is a side view showing the parts in the positions which they occupy when the load is upright and prior to the lowering thereof to transfer the weight to the truck. Fig. 3 is a detail view in perspective of the cradle. Fig. 4 is detail view in perspective of one of the spacing-strips.

Similar numerals of reference indicate cor-

responding parts in all the figures of the drawings.

1 designates a track to convey trucks 2 to a drying-kiln, (not shown,) the rails comprising said track being supported by suitable trestle-work 3. The truck is provided with supporting-wheels 4 of any suitable construction designed to traverse the track-rails.

Arranged, preferably, between the extremities of the track-rails is a vertically-movable support 5, which, in the construction illustrated, is provided with longitudinal supporting beams or rests 6, which are pivotally supported at one end, as by means of posts 7, and are adjustably supported at the other end for vertical movement controlled by adjusting devices 8. In the construction illustrated these adjusting devices consist of jacks having operating-handles 9 and provided with plungers 10.

The means which I employ for supporting the lumber preparatory to transferring it to the truck consist of a cradle 11, having parallel side rockers 12, which rest upon the beams 6 of the supporting-frame and are connected by transverse tie-rods 13. These rockers have segmentally or circumferentially curved outer edges 14 and perpendicularly-disposed inner edges 15, whereby when the cradle is in the position shown in Fig. 1, otherwise known as the "loading" position, the perpendicularly-disposed edges 15 are arranged at an inclination to a horizontal plane, and when the cradle is in the position shown in Fig. 2, preparatory to depositing the weight upon the truck, said edges 15 are, respectively, vertical and horizontal, whereby the horizontal edge is approximately parallel with the track, and hence with the truck which traverses the track. In the construction illustrated these rockers consist of metal plates bolted or riveted together at their contiguous extremities, and the combined outer edges thereof form a segment of a circle described on a center between the sides of the angle formed by the inner edges of the rocker, and as the center of a homogeneous body or pile corresponds with the center of gravity thereof, and as the bearing-point of the rocker is always in the vertical plane of the center from which the curve of the rocker is described, it is obvious that the bearing-points of the cra-

dle upon the supports or rests 6 will be in the vertical plane of the center of gravity of the load.

To load the cradle when in the position shown in Fig. 1, the boards or planks are arranged in tiers or layers parallel with the tie-rods by which the rockers are connected, and between each two contiguous layers of the boards or planks or other members comprising the load are disposed the transverse spacing-bars 16. Hence when the cradle is arranged in the vertical position shown in Fig. 2 these spacing-bars or strips are arranged in vertical planes between the parallel vertical planes of the layers of boards or planks, and in order to prevent the bars or strips from dropping out or becoming displaced either during the loading of the apparatus or subsequently, when by reason of drying the members of the load are caused to shrink, I preferably provide the strips at their upper extremities with shoulders or stops 17, adapted to rest upon the upper edges of the uppermost boards or planks of the several layers or tiers.

When the cradle has been completely loaded and while it is still in the inclined position shown in Fig. 1, I apply to the projecting extremities of the boards or planks the rectangular clamps 18, to thus bind the members of the load and form a compact bundle. These clamps are of integral construction and are slipped upon the extremities of the members of the load parallel with the rockers until their inward movement is limited by contact with the projecting extremities of the strips or bars 16. Thus the projecting extremities of said strips or bars form stops which serve to hold the rectangular clamps in operative position.

After the load has been formed in the manner above indicated the cradle is rocked forward until one of the edges forming the angle between the arms 12<sup>a</sup> and 12<sup>b</sup> of the rockers is approximately in a horizontal plane or parallel with the track, as clearly shown in Fig. 2, after which, by means of the adjusting devices 8, the support 5 is lowered until the truck-wheels coming in contact with the tracks the load is shifted from the rockers to the truck.

After the loaded truck has proceeded along the track toward the kiln the cradle, with an empty truck, may be again elevated to the position shown in Fig. 2 and rocked, as before, to the inclined or loading position indicated in Fig. 1.

By reason of the balancing of the cradle or loading-frame in the manner above described it may be moved from one position to the other without the use of mechanical devices, and hence the operation of the apparatus is materially facilitated and the transfer of a load from the cradle or loading-frame to the truck may be accomplished without loss of time.

Various changes in the form, proportion, and the minor details of construction may be

resorted to without departing from the spirit or sacrificing any of the advantages of this invention.

Having described my invention, what I claim is—

1. In a lumber-loading apparatus, a cradle having a curved bearing-surface mounted upon a support whereby the bearing-point shifts to remain in all positions of the cradle under the center of gravity of the load, substantially as specified.

2. In a lumber-loading apparatus, a cradle having a segmentally-curved outer face to traverse a support, and an angular inner face to receive a load of lumber, said inner surface serving as a former to hold the members of the load in position previous to binding, substantially as specified.

3. In a lumber-loading apparatus, a cradle having rockers provided with segmental outer and angular inner edges, said rockers being connected by tie-rods, and being adapted to traverse approximately horizontal supports or rests, the curve of the rockers being concentric with the center of gravity of a homogeneous load supported by the cradle, substantially as specified.

4. The combination with a cradle and former adapted to receive a load of lumber, of rectangular clamps having rigid or inflexible angles fitted upon the extremities of the members of the load supported by the cradle, substantially as specified.

5. The combination with a cradle and former, adapted to receive a load of lumber, of spacing strips or bars interposed transversely between contiguous layers or tiers of members comprising the load and projecting at their extremities beyond the edges of the layers or tiers, and clamps corresponding in shape with the cross-section of the load fitted upon the extremities of the said members in contact with the projecting extremities of the strips or bars, substantially as specified.

6. The combination with a cradle and former adapted to receive a load of lumber, of spacing strips or bars interposed transversely between the layers or tiers of members comprising the load and provided with lateral shoulders to engage the exposed edges of the uppermost members, whereby said bars are held from displacement, substantially as specified.

7. The combination with a track and a truck for traversing the same, of a vertically-movable support, a cradle mounted upon the support and adapted to receive a load of lumber and carry it over the track, and means for adjusting the support to enable the cradle to be lowered to transfer the weight of the load to the truck, substantially as specified.

8. The combination with a stationary track and a truck traversing the same, of a vertically-movable support, a cradle mounted upon the support and adapted to carry said truck, the cradle having rockers provided with segmentally-curved outer edges and upright

arms to support a load of lumber upon the truck preparatory to binding, said curved edges being approximately concentric with the center of gravity of a homogeneous load  
5 arranged on the cradle, and adjusting devices for lowering the support when the cradle has been moved to arrange the truck above the track, substantially as specified.

In testimony that I claim the foregoing as my own I have hereto affixed my signature in the presence of two witnesses.

H. G. WADLEY.

Witnesses:

JOHN H. SIGGERS,  
DAISY TAYLOR.