

(No Model.)

F. S. ROLFE & W. COOLEY.
SAND BAND.

No. 259,924.

Patented June 20, 1882.

Fig. 1.

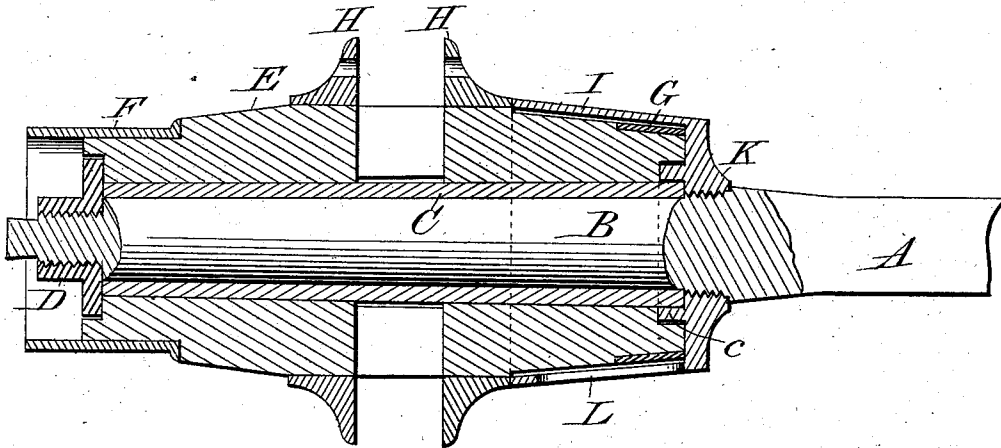

Fig. 2.

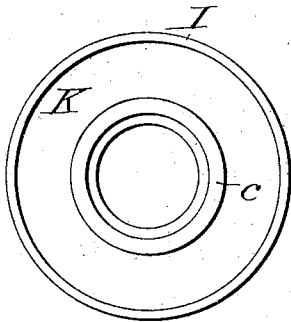

Fig. 4.

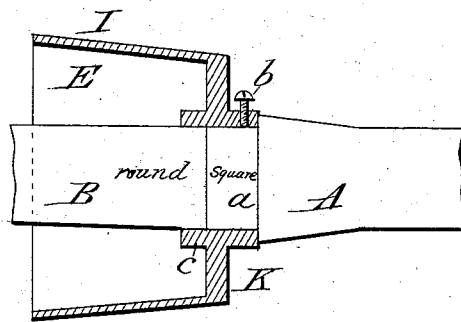
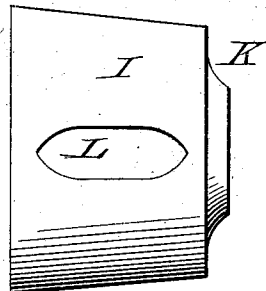

Fig. 3.



Attest:
H. B. Schott
A. R. Brown

Inventor:
Frank S. Rolfe,
William Cooley,
By J. C. Paster attorney.

UNITED STATES PATENT OFFICE.

FRANK S. ROLFE AND WILLIAM COOLEY, OF WATERBURY, VERMONT.

SAND-BAND.

SPECIFICATION forming part of Letters Patent No. 259,924, dated June 20, 1882.

Application filed April 18, 1882. (No model.)

To all whom it may concern:

Be it known that we, FRANK S. ROLFE and WILLIAM COOLEY, citizens of the United States, residing at Waterbury, in the county of Washington and State of Vermont, have invented certain new and useful Improvements in Sand-Bands for Vehicle-Axles; and we do declare the following to be a full, clear, and exact description of the invention, such as will enable others skilled in the art to which it appertains to make and use the same, reference being had to the accompanying drawings, and to the letters and figures of reference marked thereon, which form a part of this specification.

The object of this invention is to improve the construction of sand-bands for vehicle-axles; and the invention consists in certain peculiarities in the construction, combination, and arrangement of parts, as hereinafter more fully set forth.

In the annexed drawings, illustrating the invention, Figure 1 is a central longitudinal section of a vehicle-hub and attached parts. Fig. 2 is a plan of the inner side of the sand-band. Fig. 3 is a bottom view of the same, and Fig. 4 illustrates a modification in the manner of constructing the sand-band.

Like letters are used to designate the same parts in the several views.

The axle A and its arm B are preferably composed of metal, the arm being passed through the metal axle box or bearing C, and secured at its outer end by a flanged axle-nut, D, in the usual manner.

The wooden hub E, surrounding the axle-box, is strengthened by metallic bands F G at each end, and is provided at its center, on each side of the spoke-sockets, with flanged bands H H, by means of which the spokes are secured in place.

At the inner end of the hub is arranged a metallic sand band or guard composed of the sleeve I and perforated cap or plate K. These parts are preferably cast in one piece, but may be made separate, if desired. The sleeve or band I is sufficiently large to surround the inner end of the hub, extending to the inner flanged band, H, and forms a space around the end of the hub sufficient to allow the latter to revolve without friction. In its lower side is an elongated opening, L, for the escape of sand and dust.

The perforated cap or guard K, that may be formed integral with the band I or separate

therefrom, is expanded centrally to form a collar that engages with the axle-arm. The opening or collar thus formed may be circular and provided with screw-threads engaging with corresponding threads on the axle-arm, as shown in Fig. 1; or said opening may be square at its outer side to correspond with a square portion, a, formed on the axle-arm, to which the collar or flanged portion of the cap will be secured by means of a set-screw, b, as shown in Fig. 4. A circular collar or projection, c, is formed on the inner side of the cap or guard K, and may be arranged to surround the inner end of the axle-box C, as shown in Fig. 1, or may abut against the end of the same, as shown in Fig. 4. This collar or projection, c, in either case, is arranged to enter a corresponding annular recess in the end of the hub, the opposite end of the hub being also recessed for the reception of the axle-nut, by means of which the parts are securely connected.

It will be observed that when the band I and guard or protector K are formed in one piece and secured to the axle by screw-threads, as shown in Fig. 1, the axle-arm is upset or of varying thickness; but when the parts are connected, as shown in Fig. 4, the axle-arm is of the same thickness throughout.

Having thus described our invention, what we claim as new, and desire to secure by Letters Patent, is—

1. A metallic sand guard or protector consisting essentially of a perforated plate having an internal collar or annular projection adapted to receive the inner end of the axle-box, substantially as shown and described.

2. The combination, with an axle, of a metallic sand guard or protector composed of a perforated plate, K, having an internal collar, c, with an annular recess inside to receive the round part of the axle-arm, and square outside to receive the square part of the axle, substantially as shown and described.

3. The combination, with the axle A and its arm B, of the hub E, band I, and perforated plate K, having an internal collar, c, substantially as shown and described.

In testimony whereof we affix our signatures in presence of two witnesses.

FRANK S. ROLFE.

WILLIAM COOLEY.

Witnesses:

IRA A. MARSHALL,

D. B. COLE.