



- (51) International Patent Classification:  
A47K 5/12 (2006.01) A47K 5/14 (2006.01)
- (21) International Application Number:  
PCT/US2015/011081
- (22) International Filing Date:  
13 January 2015 (13.01.2015)
- (25) Filing Language: English
- (26) Publication Language: English
- (30) Priority Data:  
61/927,756 15 January 2014 (15.01.2014) US
- (71) Applicant: **GOJO INDUSTRIES, INC.** [US/US]; One Gojo Plaza, Suite 500, P.O. Box 991, Akron, OH 44309 (US).
- (72) Inventors: **HARRIS, Donald, R.**; 68 Old Forge Road, Tallmadge, OH 44278 (US). **QUINLAN, Robert, L.**; 3466 Charring Cross Drive, Stow, OH 44224 (US). **MCN-**

**ULTY, John, J.**; 8712 Breckenridge Oval, Broadview Heights, OH 44147 (US).

(74) Agent: **BONNER, Chet, J.**; Calfee, Halter & Griswold LLP, The Calfee Building, 1405 East Sixth St., Cleveland, OH 44114 (US).

(81) Designated States (unless otherwise indicated, for every kind of national protection available): AE, AG, AL, AM, AO, AT, AU, AZ, BA, BB, BG, BH, BN, BR, BW, BY, BZ, CA, CH, CL, CN, CO, CR, CU, CZ, DE, DK, DM, DO, DZ, EC, EE, EG, ES, FI, GB, GD, GE, GH, GM, GT, HN, HR, HU, ID, IL, IN, IR, IS, JP, KE, KG, KN, KP, KR, KZ, LA, LC, LK, LR, LS, LU, LY, MA, MD, ME, MG, MK, MN, MW, MX, MY, MZ, NA, NG, NI, NO, NZ, OM, PA, PE, PG, PH, PL, PT, QA, RO, RS, RU, RW, SA, SC, SD, SE, SG, SK, SL, SM, ST, SV, SY, TH, TJ, TM, TN, TR, TT, TZ, UA, UG, US, UZ, VC, VN, ZA, ZM, ZW.

(84) Designated States (unless otherwise indicated, for every kind of regional protection available): ARIPO (BW, GH, GM, KE, LR, LS, MW, MZ, NA, RW, SD, SL, ST, SZ,

[Continued on next page]

(54) Title: PUMPS WITH ANGLED OUTLETS, REFILL UNITS AND DISPENSERS HAVING ANGLED OUTLETS

(57) Abstract: Exemplary pumps, refill units and dispensers having angled outlets are disclosed herein. An exemplary refill unit for dispensing fluid on a hand includes a container and a pump. The pump includes an angled outlet passage. Fluid flowing out of the angled outlet passage is directed toward the palm of a hand when fluid is dispensed.

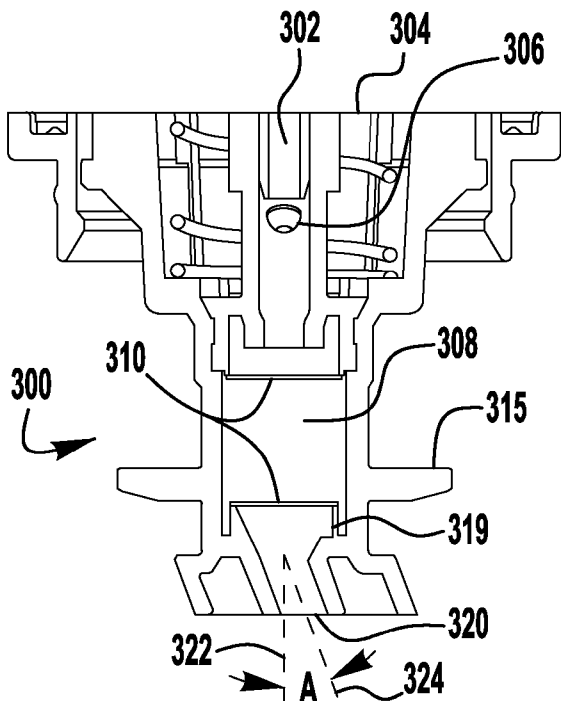

**FIG. 3**

WO 2015/108827 A1

TZ, UG, ZM, ZW), Eurasian (AM, AZ, BY, KG, KZ, RU, TJ, TM), European (AL, AT, BE, BG, CH, CY, CZ, DE, DK, EE, ES, FI, FR, GB, GR, HR, HU, IE, IS, IT, LT, LU, LV, MC, MK, MT, NL, NO, PL, PT, RO, RS, SE, SI, SK, SM, TR), OAPI (BF, BJ, CF, CG, CI, CM, GA, GN, GQ, GW, KM, ML, MR, NE, SN, TD, TG).

**Declarations under Rule 4.17:**

— *of inventorship (Rule 4.17(iv))*

**Published:**

— *with international search report (Art. 21(3))*

**PUMPS WITH ANGLED OUTLETS, REFILL UNITS AND DISPENSERS HAVING  
ANGLED OUTLETS**

**RELATED APPLICATIONS**

[0001] This application claims priority to and the benefits of U.S. Provisional Patent Application Serial No. 61/927,756 filed on January 15, 2014 and entitled “PUMPS WITH ANGLED OUTLETS, REFILL UNITS AND DISPENSERS HAVING ANGLED OUTLETS,” which is incorporated herein by reference in its entirety.

**TECHNICAL FIELD**

[0002] The present invention relates generally to liquid dispenser systems and more particularly to pumps with angled outlets, refill units and dispensers having angled outlets.

**BACKGROUND OF THE INVENTION**

[0003] Liquid dispenser systems, such as liquid soap and sanitizer dispensers, provide a user with an amount of liquid upon actuation of the dispenser. Inverted dispensers for soaps and lotions often have an outlet that extends downward and dispenses fluid straight down on a users' hand in a pile. It has been discovered that it is more desirable for the soap or lotion to dispense across the users hand instead of in a pile.

**SUMMARY**

[0004] Exemplary pumps, refill units and dispensers having angled outlets are disclosed herein. An exemplary refill unit for dispensing fluid on a hand includes a container and a pump. The pump includes an angled outlet passage. Fluid flowing out of the angled outlet passage is directed toward the palm of a hand when fluid is dispensed.

[0005] Another exemplary refill unit for an inverted dispenser includes a container and a pump. A vertical axis extends through the container and at least a portion of the pump. The

pump has an outlet passage and at least a portion of the outlet passage extends at an angle from the vertical axis.

[0006] An exemplary pump includes a compressible liquid chamber, a one-way liquid inlet valve and a one-way liquid outlet valve. In addition, the pump includes an angled outlet passage. The angled outlet passage directs fluid out of the pump at an angle of between about 5 and about 35 degrees from a vertical axis.

[0007] In this way, a simple and economical apparatus and method of dispensing fluids are provided.

### **BRIEF DESCRIPTION OF THE DRAWINGS**

[0008] These and other features and advantages of the present invention will become better understood with regard to the following description and accompanying drawings in which:

[0009] Figure 1 is a cross-section of an exemplary liquid dispenser for a pump with a vertical dispensing movement and a refill unit;

[0010] Figure 2 is a cross-section of an exemplary liquid dispenser for a pump with a horizontal dispensing movement and a refill unit;

[0011] Figure 3 is partial cross-section of an exemplary embodiment of a vertical foam pump having angled outlet;

[0012] Figure 4 is partial cross-section of an exemplary embodiment of a vertical liquid pump having angled outlet;

[0013] Figure 5 is partial cross-section of an exemplary embodiment of a horizontal foam pump having angled outlet; and

[0014] Figure 6 is partial cross-section of an exemplary embodiment of a horizontal liquid pump having angled outlet.

### **DETAILED DESCRIPTION**

[0015] Figure 1 illustrates an exemplary embodiment of a dispenser 100. The cross-section of Figure 1 is taken through the housing 102 to show the pump 120 and container 116. Dispenser 100 includes a disposable refill unit 110. The disposable refill unit 110 includes a

container 116 connected to pump 120. The dispenser 100 may be a wall-mounted system, a counter-mounted system, an un-mounted portable system movable from place to place or any other kind of liquid dispenser system. Dispenser 100 may be a foam dispenser or a liquid dispenser.

[0016] The container 116 forms a liquid reservoir that contains a supply liquid (which may be foamable) within the disposable refill unit 110. In various embodiments, the contained liquid could be, for example, a soap, a sanitizer, a cleanser, a disinfectant. In the exemplary disposable refill unit 110, the container 116 may be a collapsible container or a non-collapsible container and can be made of thin plastic or like material. The container 116 may advantageously be refillable, replaceable or both refillable and replaceable.

[0017] In the event the liquid stored in the container 116 of the installed disposable refill unit 110 runs out, or the installed refill unit 110 otherwise has a failure, the installed refill unit 110 may be removed from the dispenser 100. The empty or failed disposable refill unit 110 may then be replaced with a new disposable refill unit 110.

[0018] The housing 102 of the dispenser 100 contains one or more actuating members 104 to activate the pump 120. As used herein, actuator or actuating members or mechanisms include one or more parts that cause the dispenser 100 to move liquid, air or foam. Actuator 104 is generically illustrated because there are many different kinds of pump actuators which may be employed in the foam dispenser 100. The actuator 104 of the dispenser 100 may be any type of actuator such as, for example, a manual lever, a manual pull bar, a manual push bar, a manual rotatable crank, an electrically activated actuator or other means for actuating the pump 120. Electronic actuators may additionally include a sensor 132 for detecting the presence of an object and to provide for a hands-free dispenser system with touchless operation. Various intermediate linkages, such as for example linkage 105, connect the actuator member 104 to the pump 120 within the system housing 102. An aperture 115 is located in bottom plate 103 of housing 102 and allows liquid dispensed from the nozzle 125 of pump 120 to be dispensed to a user.

[0019] Figure 2 illustrates an exemplary embodiment of a foam dispenser 200. The cross-section of Figure 2 is taken through the housing 202 to show the foam pump 220 and container 216. Foam dispenser 200 includes a disposable refill unit 210. The disposable refill unit 210 includes a non-collapsible container 216 connected to foam pump 220. The

foam dispenser 200 may be a wall-mounted system, a counter-mounted system, an un-mounted portable system movable from place to place or any other kind of foam dispenser system. Some of the exemplary embodiments described herein have foam pumps; that is, they contain a liquid pump and an air compressor. However, the inventive angled outlet system described herein works equally well with a liquid pump that does not include an air compressor.

**[0020]** The container 216 forms a liquid reservoir that contains a supply of a foamable liquid within the disposable refill unit 210. In various embodiments, the contained liquid could be for example a soap, a sanitizer, a cleanser, a disinfectant or some other liquid that may be foamable or not foamable (in the case of a liquid only pump). In the exemplary disposable refill unit 210, the container 216 is a non-collapsible container and can be made of thin plastic or like material. In other embodiments, the container 216 may be formed by a rigid housing member, or have any other suitable configuration for containing the foamable liquid without leaking. The container 216 may advantageously be refillable, replaceable or both refillable and replaceable.

**[0021]** In the event the liquid stored in the container 216 of the installed disposable refill unit 210 runs out, or the installed refill unit 210 otherwise has a failure, the installed refill unit 210 may be removed from the foam dispenser 200. The empty or failed disposable refill unit 210 may then be replaced with a new disposable refill unit 210.

**[0022]** In one embodiment, the housing 202 of the foam dispenser 200 only extends part way around the container 216 thereby exposing at least a portion of the container 216. In such an embodiment, having a container that does not collapse as liquid is pumped out is aesthetically pleasing. The housing 202 of the foam dispenser 200 contains one or more actuating members 204 to activate the pump 220. As used herein, actuator or actuating members or mechanism includes one or more parts that cause the dispenser 200 to move liquid, air or foam. Actuator 204 is generically illustrated because there are many different kinds of pump actuators which may be employed in the foam dispenser 200. The actuator of the foam dispenser 200 may be any type of actuator such as, for example, a manual lever, a manual pull bar, a manual push bar, a manual rotatable crank, an electrically-activated actuator or other means for actuating the foam pump 220 which includes a liquid pump portion 224 and air compressor portion 222. Electronic actuators may additionally include a sensor (not shown) to provide for a hands-free dispenser system with touchless operation. In

one embodiment, actuator 204 is connected to housing 202 by a hinge member 206. Various intermediate linkages, such as for example linkage 205, connect the actuator member 204 to the foam pump 220 within the system housing 202. In one embodiment, linkage 205 has a socket 207 that snaps onto a ball (not shown) at the proximate end of piston (not shown). An aperture 215 in bottom plate 203 of housing 202 allows foam dispensed from the nozzle 225 of foam pump 220 to be dispensed to a user.

**[0023]** Figure 3 is a partial cross-section of an exemplary embodiment of a foam pump 300. Foam pump 300 uses a vertical upward and downward movement to dispense fluid. Foam pump 300 may be any vertical movement foam pump, such as for example, the foam pump disclosed in U.S. Pat. 8,272,539, filed on December 3, 2008 and entitled Angled Slot Foam Dispenser, which is incorporated herein by reference in its entirety, and a pull foam pump disclosed in U.S. Pat. App. 13/747,881 filed on January 23, 2013 and entitled Pull Pumps, Refill Units, And Dispensers For Pull Pumps, which is also incorporated herein by reference. The workings of these foam pumps may be the same as the inventive pumps disclosed herein with the exception that outlet 320 is an angled outlet that provides a foam output that covers a larger area on a user's hands than the prior art outlets.

**[0024]** Foam pump 300 includes an actuator engagement member 315 that engages an actuator (not shown) of a dispenser (not shown). In addition, foam pump 300 includes a liquid inlet passage 302. Foam pump 300 also includes a compressible air chamber 304 and an air inlet aperture 306 leading from the compressible air chamber to the liquid inlet passage 302. Foam pump 300 includes a foaming chamber 308 that includes a pair of screens 310. In this exemplary embodiment, located below foaming chamber 308 is a funnel shaped passage 319. An angled outlet 320 is located at the end of pump 300. A centerline 322 of pump 300 is illustrated in Figure 3. Centerline 324 is the center of angled outlet 320. In some embodiments, the angle A between centerline 322 and the centerline 324 of angled outlet 320 is between about 5 degrees and about 30 degrees. The angled outlet 320 allows foam to be dispensed in a larger area on a use's hands than prior art foam dispensers. In some embodiments, the length of angled outlet 320 is greater than about 1/8", in some embodiments the angled outlet is greater than about 1/4", in some embodiments, the angled outlet is less than about 1" and in some embodiments the length is less than about 2".

**[0025]** Figure 4 is a partial cross-section of an exemplary embodiment of a liquid pump 400. Liquid pump 400 uses a vertical upward and downward movement to dispense fluid.

Liquid pump 400 may be any vertical movement liquid pump, such as for example, the liquid pump disclosed in U.S. Pat. 8,002,150 filed on July 30, 2007 and entitled Split Engagement Flange For Soap Dispenser Pump Piston, which is incorporated herein by reference in its entirety. In addition, the foam pumps disclosed above may be modified to remove the air pump portion to become liquid pumps. The workings of these liquid pumps may be the same as the inventive pumps disclosed herein, with the exception that outlet 420 is an angled outlet that provides a liquid output that covers a larger area than the prior art outlets. Liquid pump 400 includes an actuator engagement member 415 that engages the actuator (not shown) of a dispenser (not shown). Liquid pump 400 includes a liquid inlet passage 402. An angled outlet 420 is located at the end of pump 400. The length of liquid outlet 420 is longer than the length of the liquid outlet illustrated in foam pump 300, however, the liquid outlet 420 may be any length as long as it directs the liquid out at an angle so that the area of the output on the hand is larger than the area of an outlet that dispenses straight vertically. In some embodiments, the length of angled outlet 420 is greater than about 1/8", in some embodiments the angled outlet 420 is greater than about 1/4", in some embodiments, the angled outlet 420 is less than about 1" and in some embodiments the length is less than about 2". A centerline 422 of pump 400 is illustrated in Figure 4. Centerline 424 is the center of angled outlet 420. In some embodiments, the angle B between centerline 422 and the centerline 424 of angled outlet 420 is between about 5 degrees and about 30 degrees. The angled outlet 420 allows liquid to be dispensed in a larger area than prior art liquid dispensers.

[0026] Figure 5 is a partial cross-section of an exemplary embodiment of a foam pump 500. Foam pump 500 uses a horizontal movement to dispense fluid. Foam pump 500 may be any horizontal movement foam pump, such as for example, the foam pump disclosed in U.S. Pat. App. Serial Number 13/792,115 filed on March 10, 2013 and entitled Horizontal Pumps, Refill Units And Foam Dispensers which is incorporated herein by reference in its entirety, and a horizontal foam pump disclosed in U.S. Pat. App. 13/747,909 filed on January 23, 2013 and entitled Pumps With Container Pumps, which is also incorporated by reference in its entirety. The workings of these foam pumps may be the same as the inventive pumps disclosed herein, with the exception that outlet 520 is an angled outlet that provides a foam output that covers a larger area than the prior art outlets. Foam pump 500 includes a liquid outlet valve 502, and a liquid passage 504. In addition, foam pump 500 includes an air passage 505 from a compressible air chamber (not shown) and an air inlet aperture 506



leading to the liquid inlet passage 504. Air and liquid mix together in the passage 504 and pass through foam screens 510. An angled outlet 520 is located at the end of pump 500. A centerline 522 of pump 500 is illustrated in Figure 5. Centerline 524 is the center of angled outlet 520. In some embodiments, the angle C between centerline 522 and the centerline 524 of angled outlet 520 is between about 5 degrees and about 30 degrees. The angled outlet 520 allows foam to be dispensed in a larger area than prior art foam dispensers. In some embodiments, the length of angled outlet 520 is greater than about 1/8", in some embodiments the angled outlet 520 is greater than about 1/4", in some embodiments, the angled outlet is less than about 1" and in some embodiments the length is less than about 2".

[0027] Figure 6 is a partial cross-section of an exemplary embodiment of a liquid pump 600. Liquid pump 600 uses a horizontal movement to dispense fluid. Liquid pump 600 may be any vertical movement liquid pump, such as for example, the liquid pump portion of the horizontal foam pumps incorporated by reference above without the air compressor portion, the air passages and the foaming cartridges or screens. The workings of these liquid pumps may be the same as the inventive pumps disclosed herein with the exception that outlet 620 is an angled outlet that provides a liquid output that covers a larger area than the prior art outlets with the same amount of fluids. Liquid pump 600 also includes a liquid piston 605, which is partially shown. Liquid pump 600 includes a liquid outlet valve 602 and a liquid passage 603. An angled outlet 620 is located at the end of pump 600. The length of liquid outlet 620 may be any length as long as it directs the liquid out at an angle so that the area of the output on the hand is larger than the area of an outlet that dispenses straight vertically. In some embodiments, the length of angled outlet 620 is greater than about 1/8", in some embodiments the angled outlet 620 is greater than about 1/4", in some embodiments, the angled outlet 620 is less than about 1" and in some embodiments the length is less than about 2". A centerline 622 of pump 600 is illustrated in Figure 6. Centerline 624 is the center of angled outlet 620. In some embodiments, the angle D between centerline 622 and the centerline 624 of angled outlet 620 is between about 5 degrees and about 30 degrees. The angled outlet 620 allows foam to be dispensed in a larger area than prior art foam dispensers.

[0028] In addition, the containers and or pumps may include one or more alignment members, not shown, to cause the refill unit or pumps to be installed in a dispenser to cause the outlet to angle toward a user's palm. The alignment members may be a key, a ridge, a groove, a tab or the like.

[0029] While the present invention has been illustrated by the description of embodiments thereof and while the embodiments have been described in considerable detail, it is not the intention of the applicant to restrict or in any way limit the scope of the appended claims to such detail. Additional advantages and modifications will readily appear to those skilled in the art. Therefore, the invention, in its broader aspects, is not limited to the specific details, the representative apparatus and illustrative examples shown and described. Accordingly, departures may be made from such details without departing from the spirit or scope of the applicant's general inventive concept.

**CLAIMS**

We claim:

1. A refill unit for a dispenser fluid on a hand comprising:
  - a container;
  - a pump;
  - the pump having an angled outlet passage;
  - wherein fluid flowing out of the angled outlet passage is directed toward the palm of a hand when fluid is dispensed.
2. The refill unit of claim 1 wherein the pump is a foam pump, and wherein the angled outlet passage is located downstream of a foam generator.
3. The refill unit of claim 1 wherein the angle of the angled outlet passage is about 5 to about 30 degrees from a vertical axis.
4. The refill unit of claim 1 wherein the length of the angled outlet passage is greater than about 1/8".
5. The refill unit of claim 1 wherein the length of the angled outlet passage is greater than about 1/4".
6. The refill unit of claim 1 wherein the length of the angled outlet passage is less than about 1".
7. The refill unit of claim 1 wherein the length of the angled outlet passage is less than about 2".
8. The refill unit of claim 1 further comprising an alignment member for aligning the angled outlet toward the palm of a hand when the refill unit is installed in a dispenser.
9. The refill unit of claim 1 wherein the angled outlet passage moves upward and downward during operation of the pump.
10. The refill unit of claim 1 wherein the angled outlet passage is stationary during operation of the pump.
11. The refill unit of claim 1 further comprising a liquid piston wherein the angle of the angle outlet is not parallel or perpendicular to the movement of the liquid piston.
12. A refill unit comprising:
  - a container;

- a pump;
- a vertical axis extending through the container and at least a portion of the pump
- the pump having an outlet passage;
- wherein at least a portion of the outlet passage extends at an angle from the vertical axis.
13. The refill unit of claim 12 wherein the pump is a foam pump, and the angled outlet passage is located downstream of a foam generator.
14. The refill unit of claim 12 wherein the angle of the outlet passage is about 5 to about 30 degrees from the vertical axis.
15. The refill unit of claim 12 wherein the length of the outlet passage is greater than about 1/8".
16. The refill unit of claim 12 wherein the length of the outlet passage is greater than about 1/4".
17. The refill unit of claim 12 wherein the length of the outlet passage is less than about 1".
18. A pump for a dispenser comprising:
- a compressible liquid chamber;
- a one-way liquid inlet valve;
- a one-way liquid outlet valve; and
- an angled outlet passage;
- wherein the angled outlet passage directs fluid out of the pump at an angle of between about 5 and about 35 degrees from a vertical axis.
19. The pump of claim 18 wherein the angled outlet passage moves upward and downward during operation of the pump.
20. The pump of claim 18 wherein the angled outlet passage is stationary during operation of the pump.

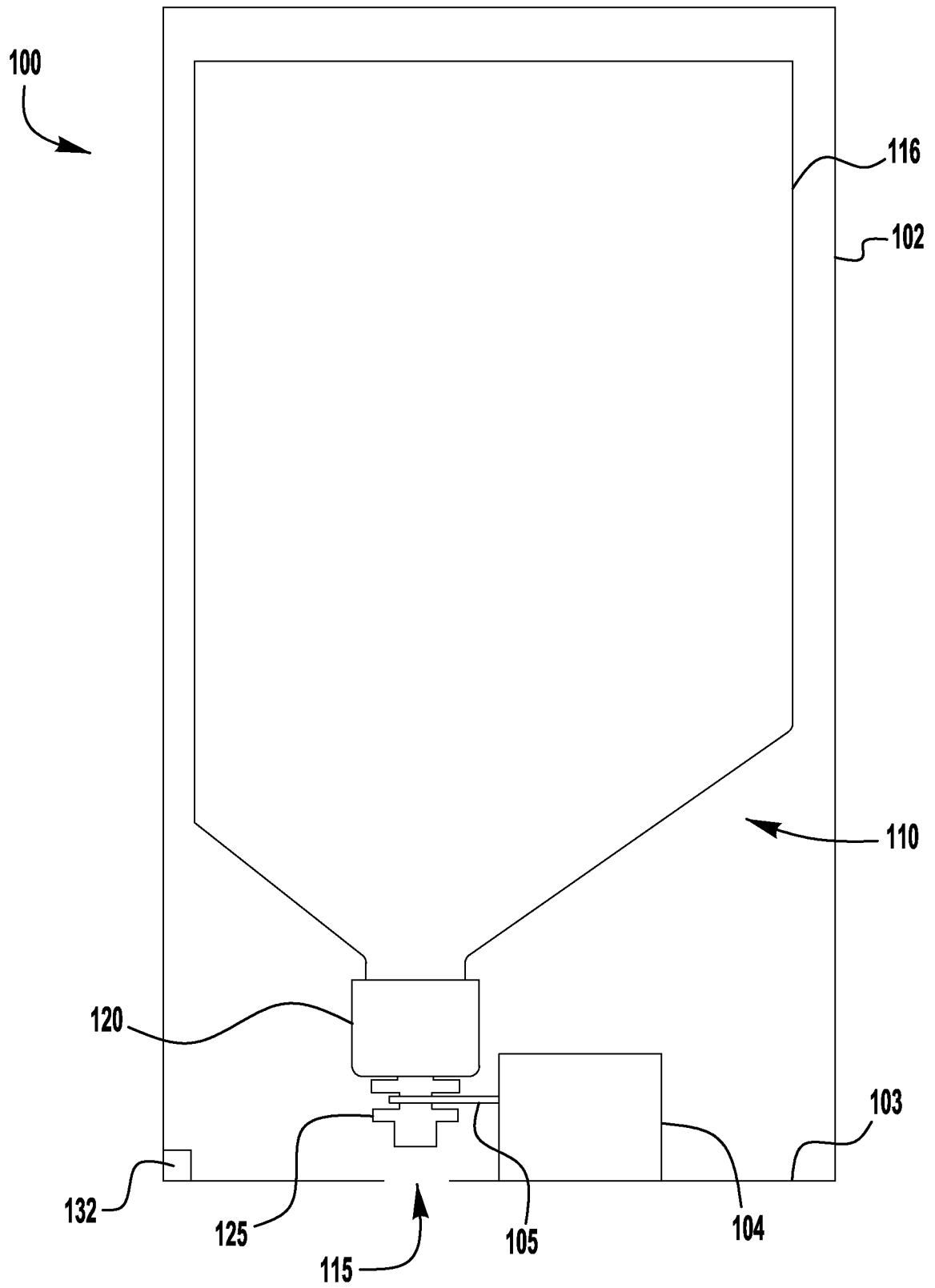

**FIG. 1**

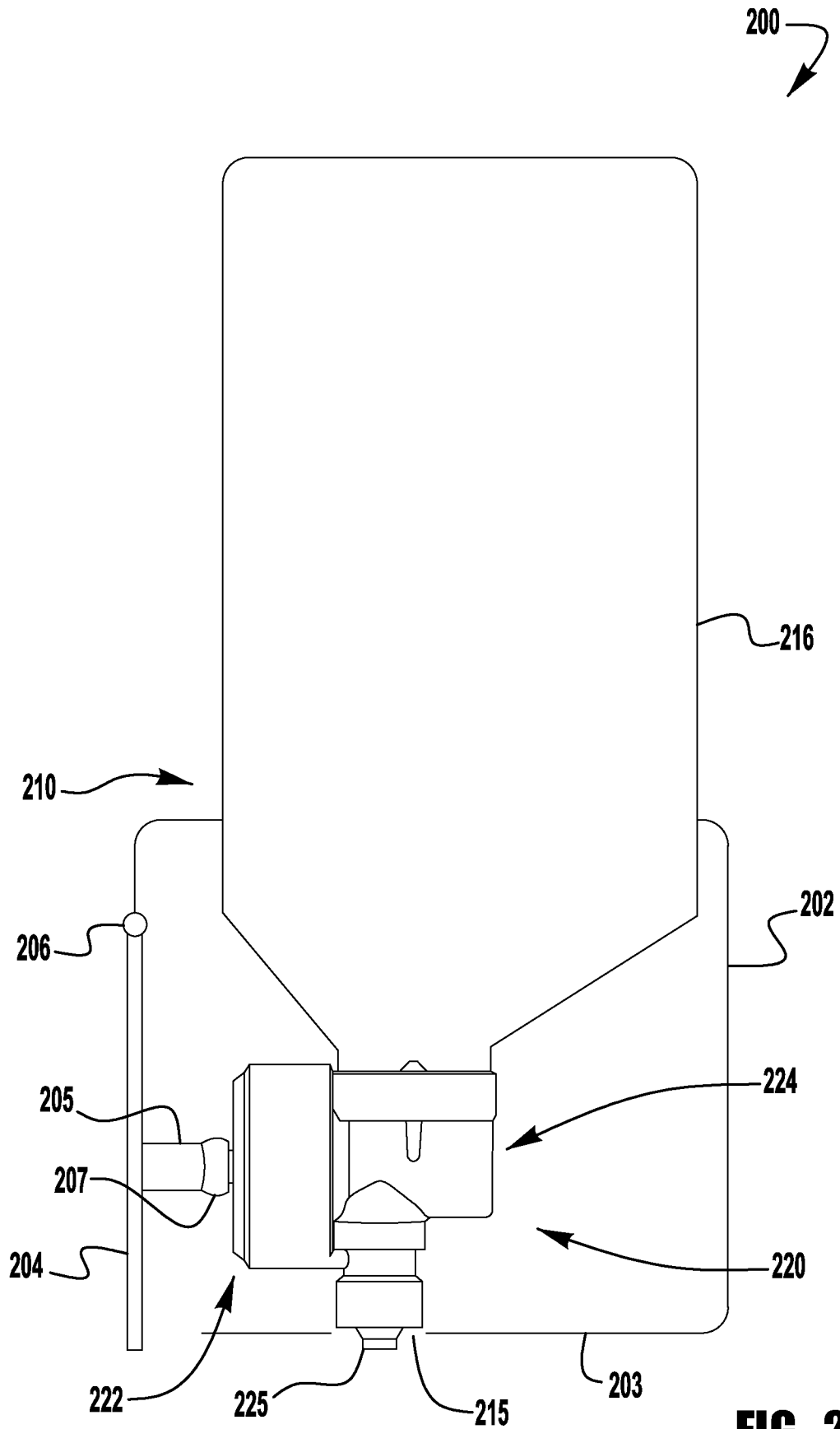

**FIG. 2**

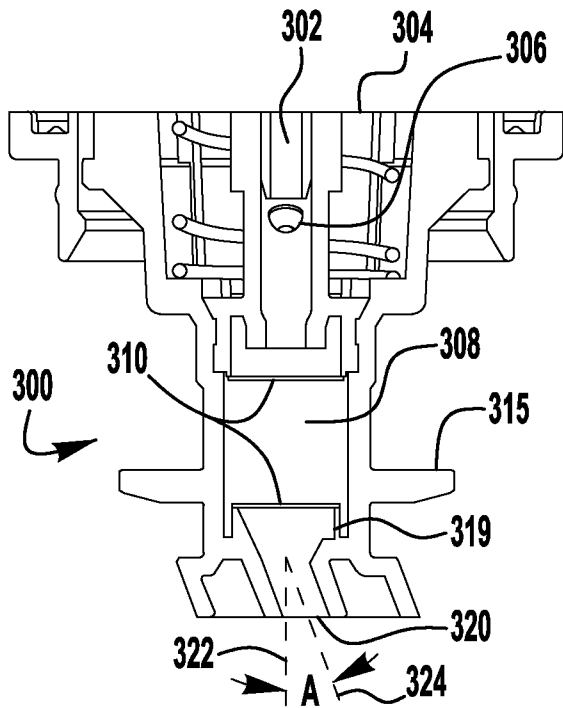

**FIG. 3**

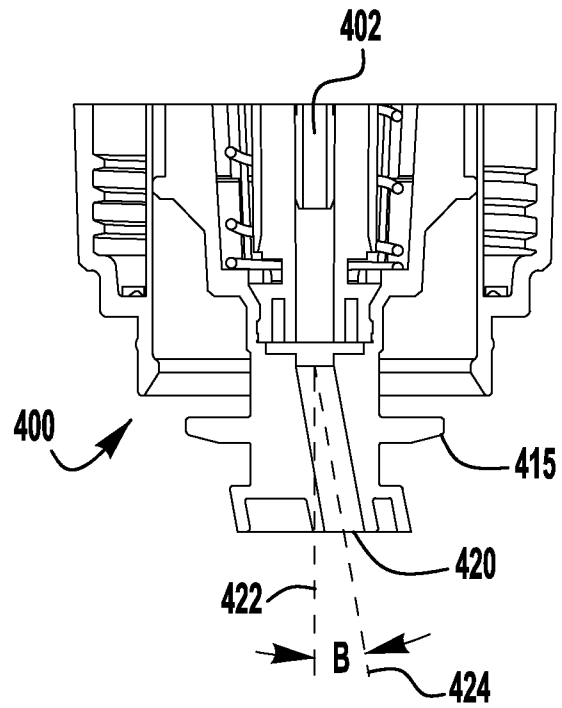

**FIG. 4**

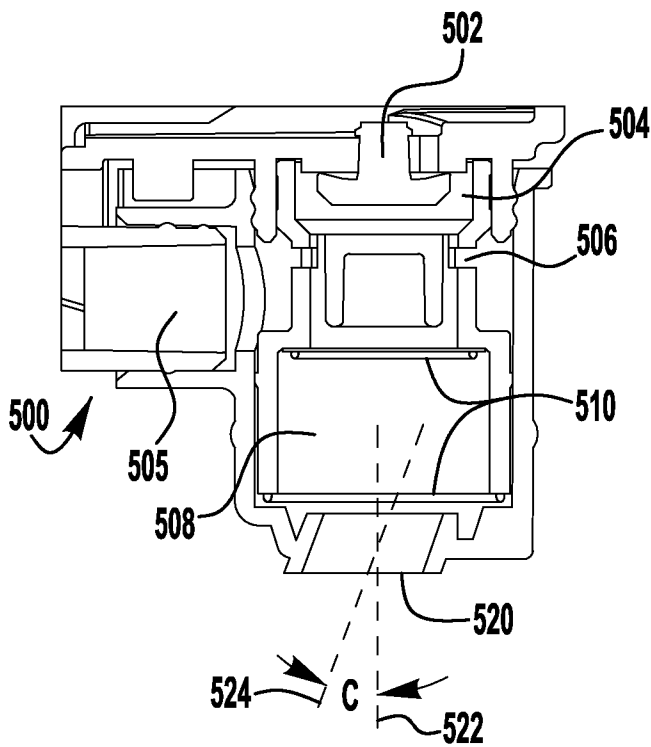

**FIG. 5**

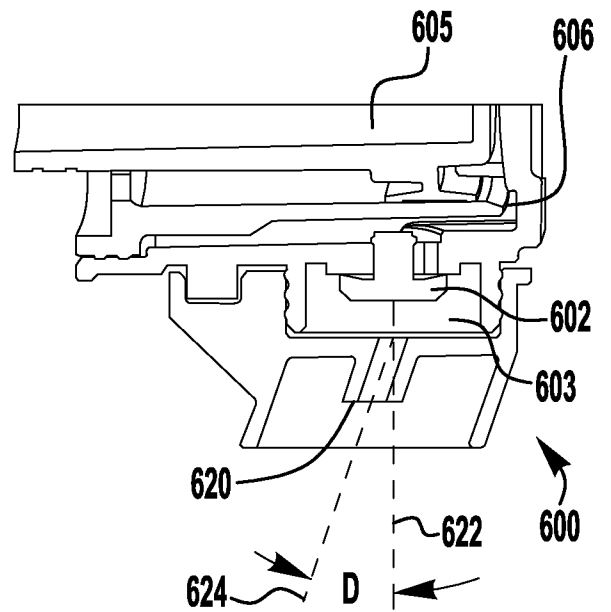

**FIG. 6**

# INTERNATIONAL SEARCH REPORT

International application No PCT/US2015/011081
---

**A. CLASSIFICATION OF SUBJECT MATTER**  
 INV. A47K5/12 A47K5/14  
 ADD.

According to International Patent Classification (IPC) or to both national classification and IPC

**B. FIELDS SEARCHED**

Minimum documentation searched (classification system followed by classification symbols)  
 A47K B05B

Documentation searched other than minimum documentation to the extent that such documents are included in the fields searched

Electronic data base consulted during the international search (name of data base and, where practicable, search terms used)

EPO-Internal, WPI Data

**C. DOCUMENTS CONSIDERED TO BE RELEVANT**

Category*	Citation of document, with indication, where appropriate, of the relevant passages	Relevant to claim No.
X	EP 2 332 453 A1 (REGENT MEDICAL LTD [GB]) 15 June 2011 (2011-06-15) paragraph [0032] - paragraph [0055]; figures -----	1-20
X	DE 20 2007 017965 U1 (NEUENDORF RONALD [DE]) 13 March 2008 (2008-03-13) paragraph [0024] - paragraph [0028]; claims 1-8; figures -----	1-20
X	NL 1 023 374 C2 (BENTFIELD EUROP BV [NL]) 7 August 2003 (2003-08-07) page 2, line 36 - page 12, line 35; figures -----	1-20

Further documents are listed in the continuation of Box C.

See patent family annex.

\* Special categories of cited documents :

- "A" document defining the general state of the art which is not considered to be of particular relevance
- "E" earlier application or patent but published on or after the international filing date
- "L" document which may throw doubts on priority claim(s) or which is cited to establish the publication date of another citation or other special reason (as specified)
- "O" document referring to an oral disclosure, use, exhibition or other means
- "P" document published prior to the international filing date but later than the priority date claimed

"T" later document published after the international filing date or priority date and not in conflict with the application but cited to understand the principle or theory underlying the invention

"X" document of particular relevance; the claimed invention cannot be considered novel or cannot be considered to involve an inventive step when the document is taken alone

"Y" document of particular relevance; the claimed invention cannot be considered to involve an inventive step when the document is combined with one or more other such documents, such combination being obvious to a person skilled in the art

"&" document member of the same patent family

Date of the actual completion of the international search

10 April 2015

Date of mailing of the international search report

23/04/2015

Name and mailing address of the ISA/

European Patent Office, P.B. 5818 Patentlaan 2  
 NL - 2280 HV Rijswijk  
 Tel. (+31-70) 340-2040,  
 Fax: (+31-70) 340-3016

Authorized officer

van de Beek-Duijker



# INTERNATIONAL SEARCH REPORT

Information on patent family members

International application No  
PCT/US2015/011081

Patent document cited in search report	Publication date	Patent family member(s)	Publication date
EP 2332453	A1	15-06-2011	AT 547036 T 15-03-2012
			EP 2332453 A1 15-06-2011
			ES 2383068 T3 18-06-2012
			US 2011127290 A1 02-06-2011
			WO 2011067654 A1 09-06-2011
-----			
DE 202007017965	U1	13-03-2008	NONE
-----			
NL 1023374	C2	07-08-2003	NONE
-----			