



US009124514B2

(12) **United States Patent**
Gopinath et al.

(10) **Patent No.:** **US 9,124,514 B2**

(45) **Date of Patent:** **Sep. 1, 2015**

(54) **SYSTEMS AND METHODS FOR SHARING L2 INFORMATION AND MAC BASED FORWARDING**

(58) **Field of Classification Search**
USPC 370/221, 252, 328, 335, 350, 370, 392;
375/356-362; 455/466
See application file for complete search history.

(75) Inventors: **Sandhya Gopinath**, Karnataka (IN);
Abhishek Chauhan, Saratoga, CA (US);
Henk Bots, Boulder City, NV (US);
Mohit Saxena, Karnataka (IN);
Ramanjaneyulu Y Talla, Karnataka (IN);
Vivekanand Rangaraman, Karnataka (IN)

(56) **References Cited**

U.S. PATENT DOCUMENTS

2007/0036161 A1* 2/2007 Mahamuni 370/392
2008/0240112 A1* 10/2008 Muqattash et al. 370/395.31
2009/0067440 A1* 3/2009 Chadda et al. 370/401

* cited by examiner

(73) Assignee: **CITRIX SYSTEMS, INC.**, Fort Lauderdale, FL (US)

Primary Examiner — Edan Orgad

Assistant Examiner — Sithu Ko

(*) Notice: Subject to any disclaimer, the term of this patent is extended or adjusted under 35 U.S.C. 154(b) by 153 days.

(74) *Attorney, Agent, or Firm* — Foley & Lardner LLP; Christopher J. McKenna; Shabbi S. Khan

(21) Appl. No.: **13/524,784**

(57) **ABSTRACT**

(22) Filed: **Jun. 15, 2012**

The present application is directed towards sharing data link layer information of network traffic distributed across a cluster of intermediary devices. A method for sharing data link layer information across a cluster includes receiving a request packet at a first intermediary device. The first intermediary device identifies a first set of data link layer information from a data link layer of the request packet. The first intermediary device modifies the request packet for transmission on a common data backplane of the cluster to include the first set of data link layer information in the request packet. The modified request packet includes a second set of data link layer information that differs from the first set of data link layer information at the data link layer. The first intermediary device transmits the modified request packet on the common data backplane of the cluster to other devices of the cluster.

(65) **Prior Publication Data**

US 2013/0336337 A1 Dec. 19, 2013

(51) **Int. Cl.**

H04L 12/56 (2006.01)
H04L 12/66 (2006.01)
H04J 3/24 (2006.01)
H04L 12/707 (2013.01)
H04L 29/06 (2006.01)

(52) **U.S. Cl.**

CPC **H04L 45/24** (2013.01); **H04L 63/0281** (2013.01); **H04L 63/166** (2013.01)

19 Claims, 19 Drawing Sheets

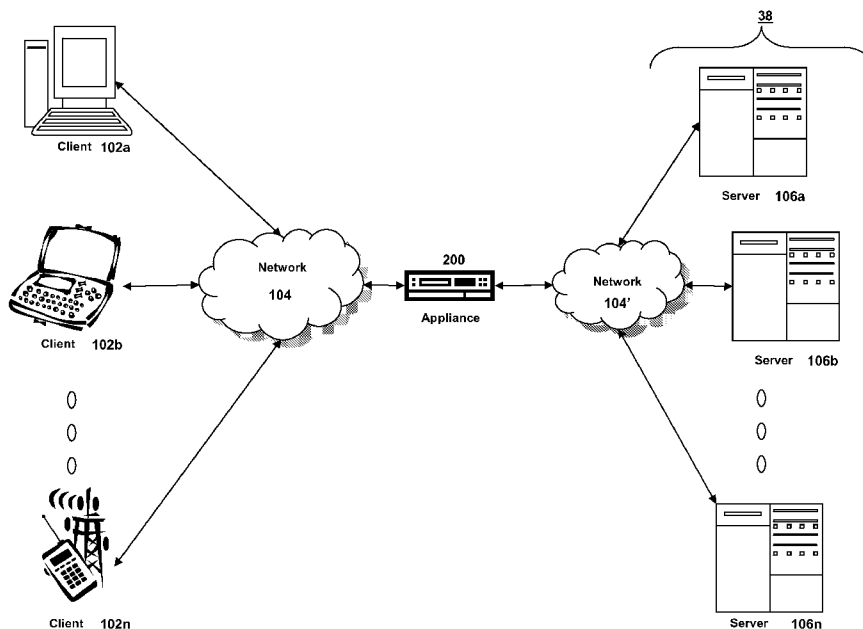

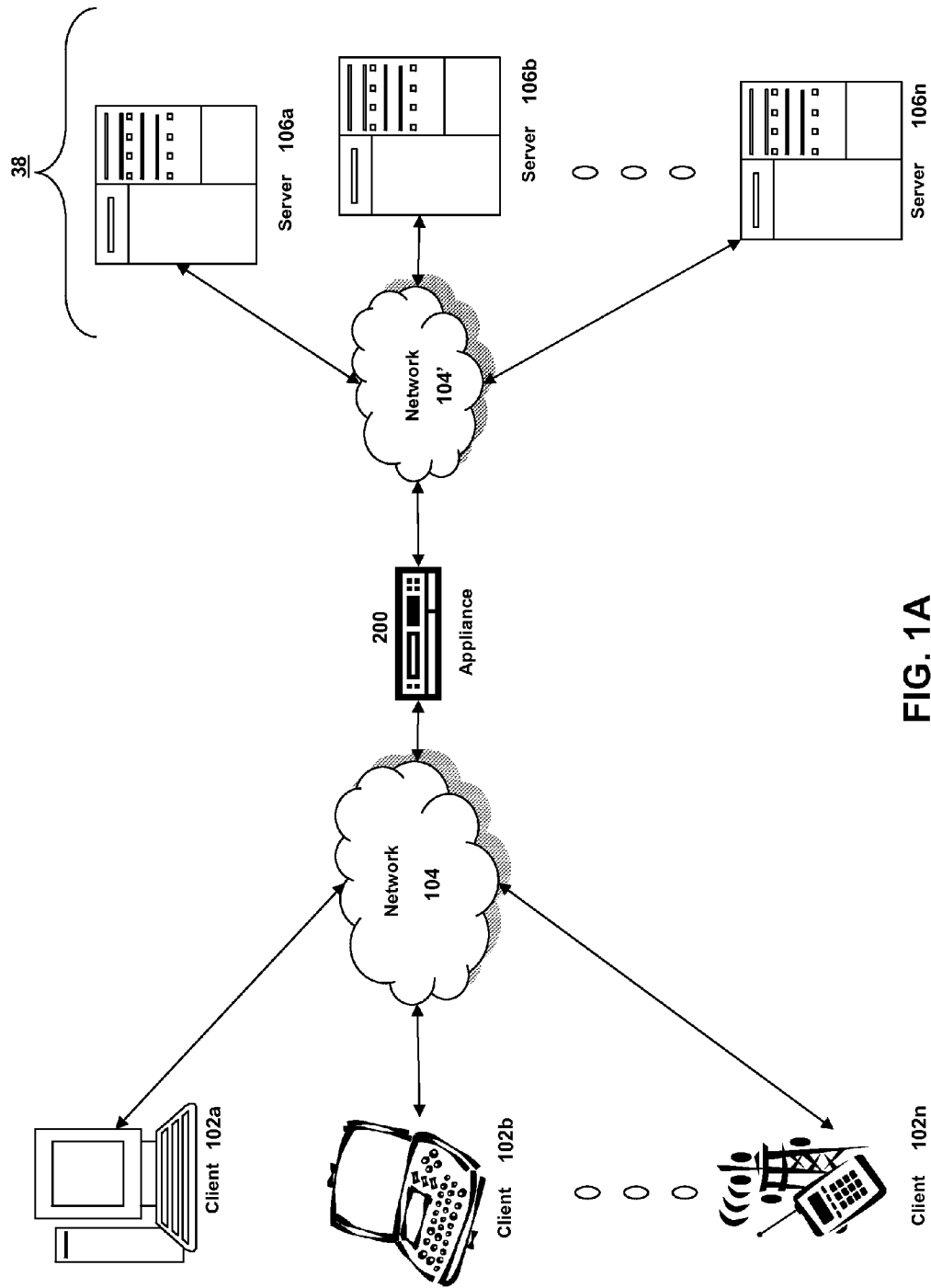

FIG. 1A

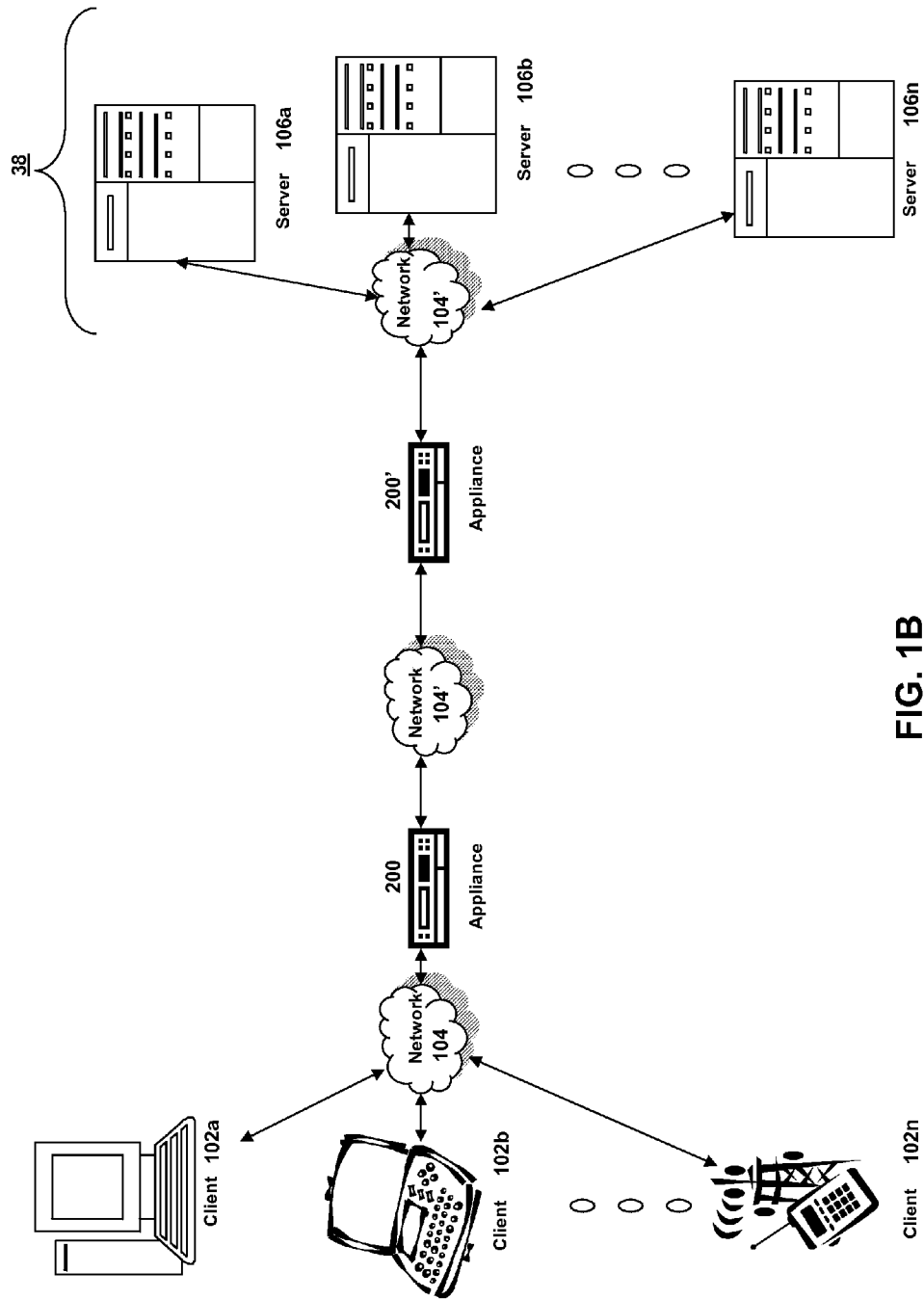

FIG. 1B

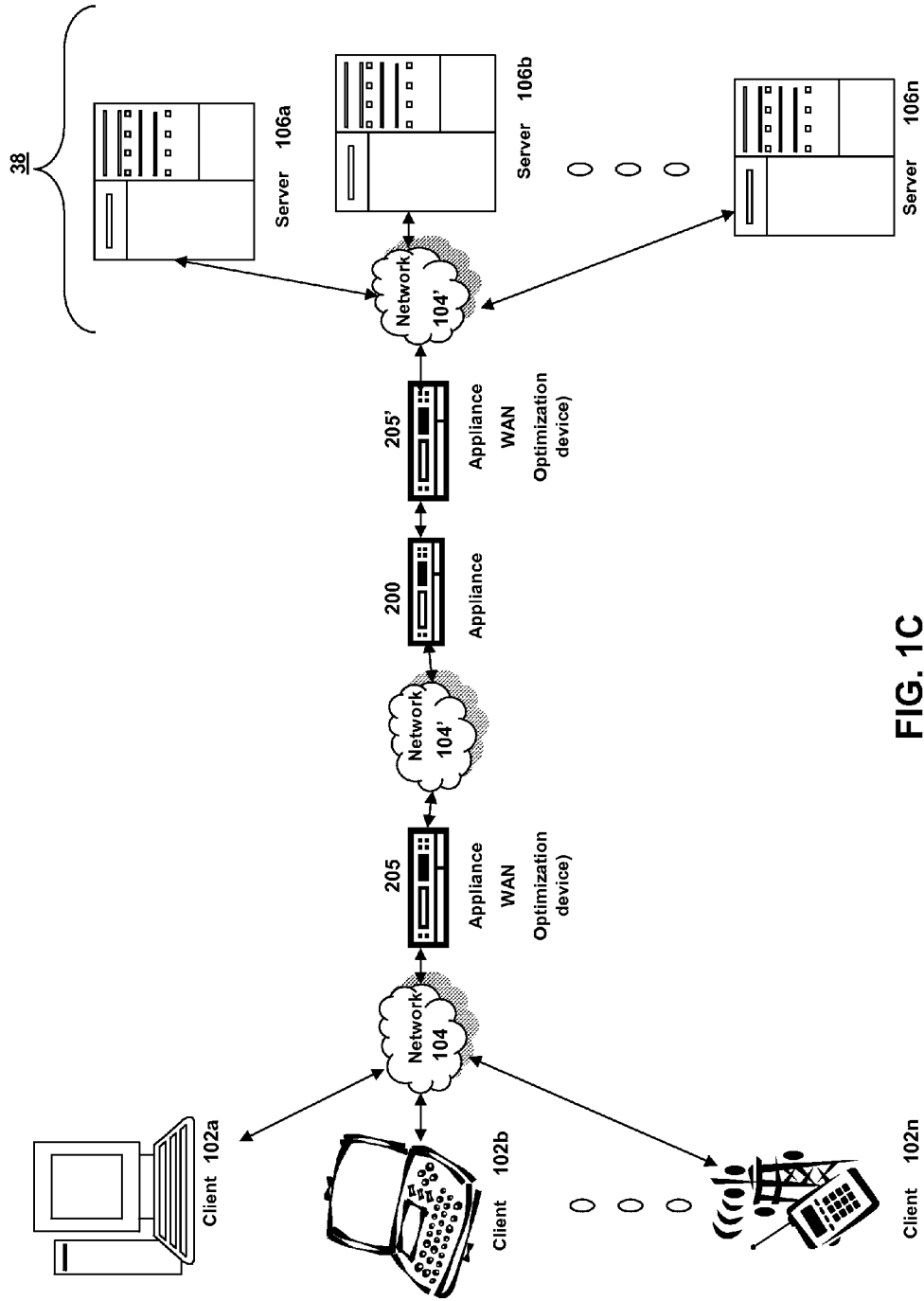

FIG. 1C

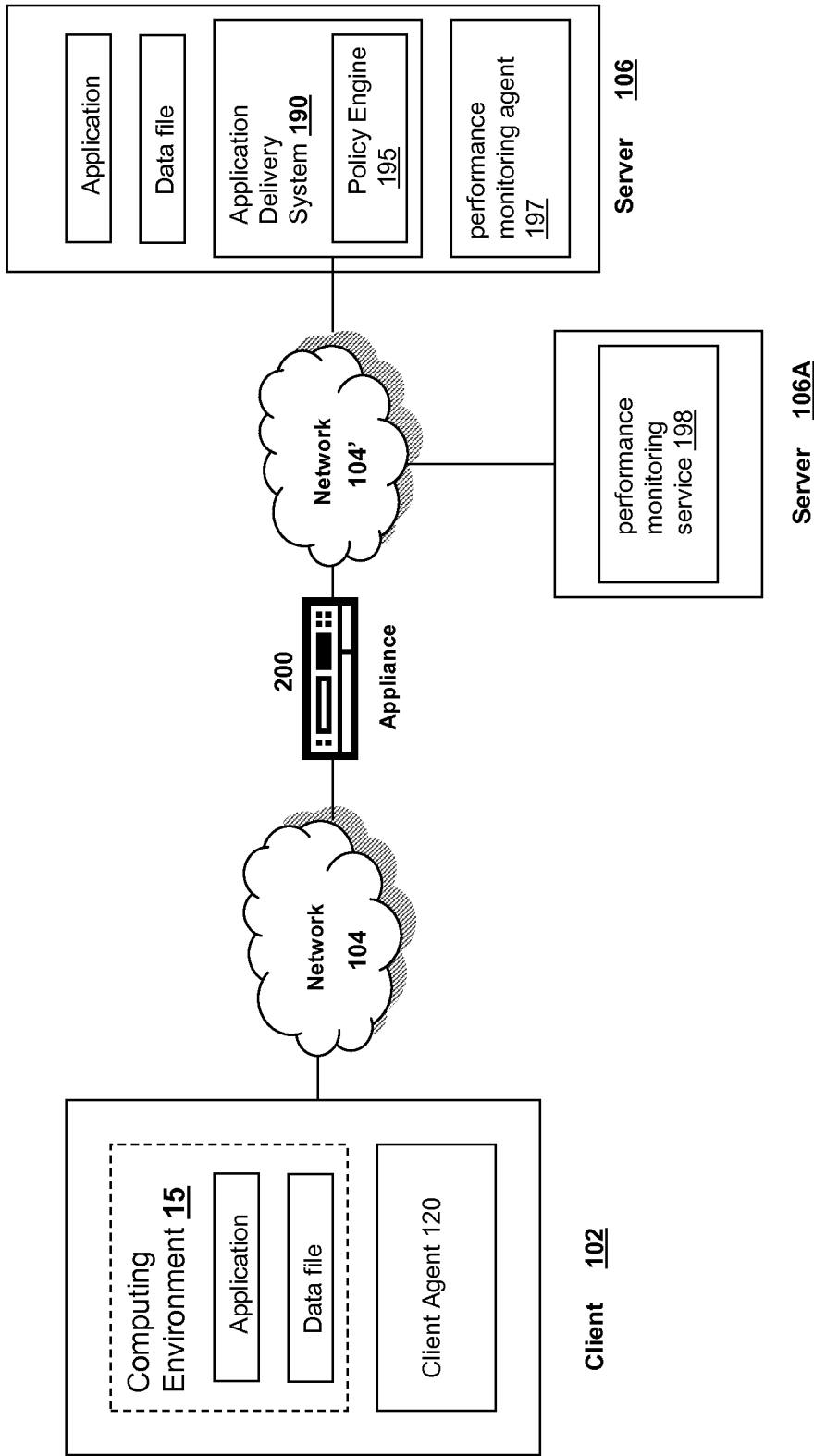

FIG. 1D

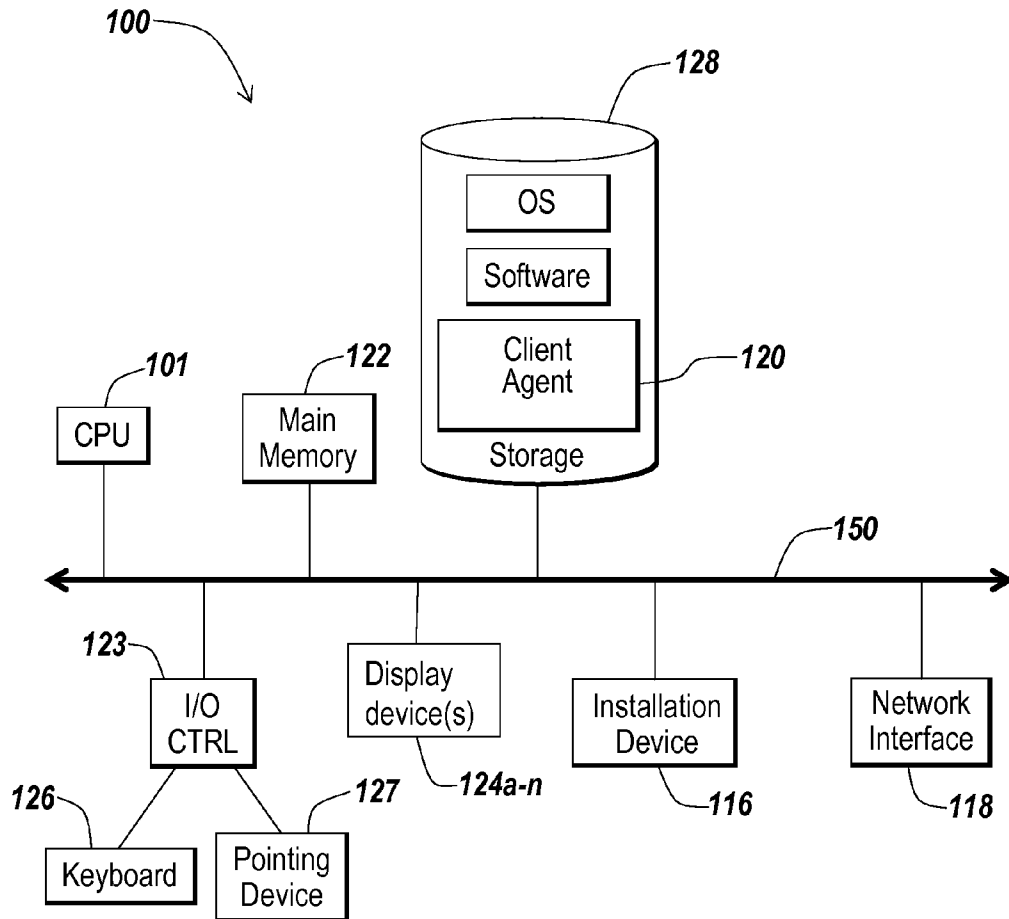

Fig. 1E

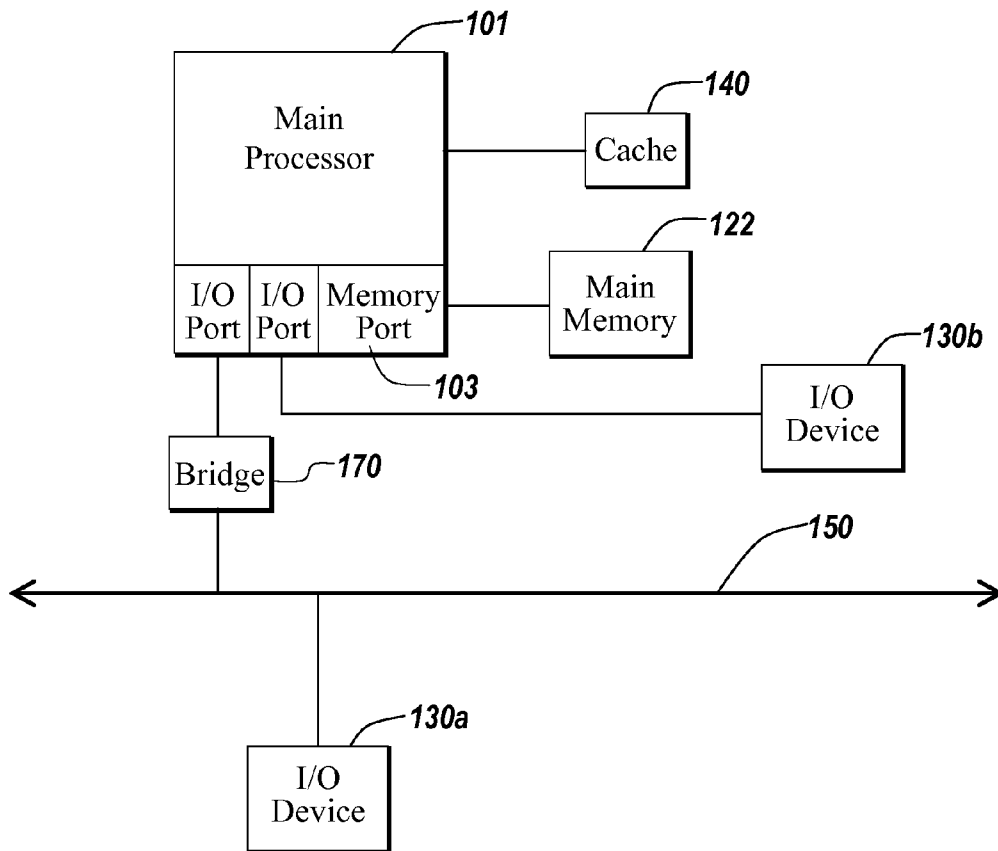

Fig. 1F

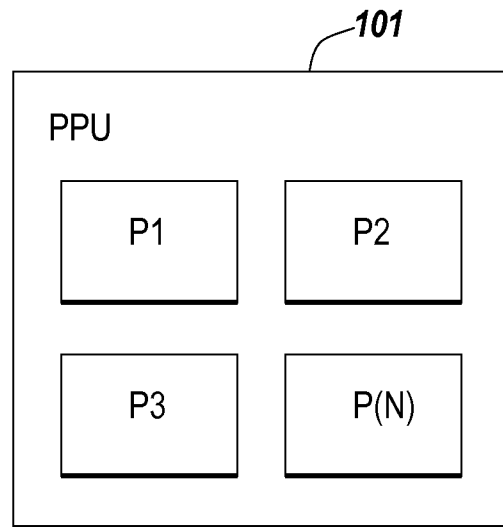

Fig. 1G

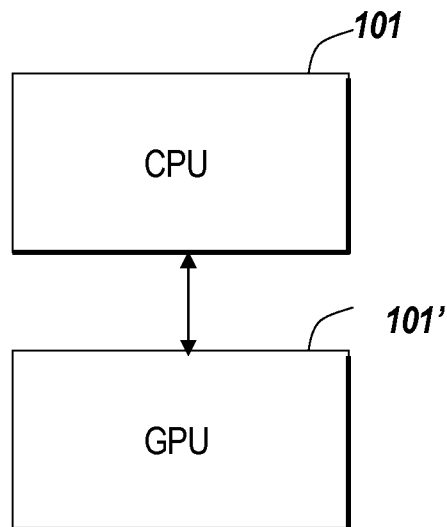

Fig. 1H

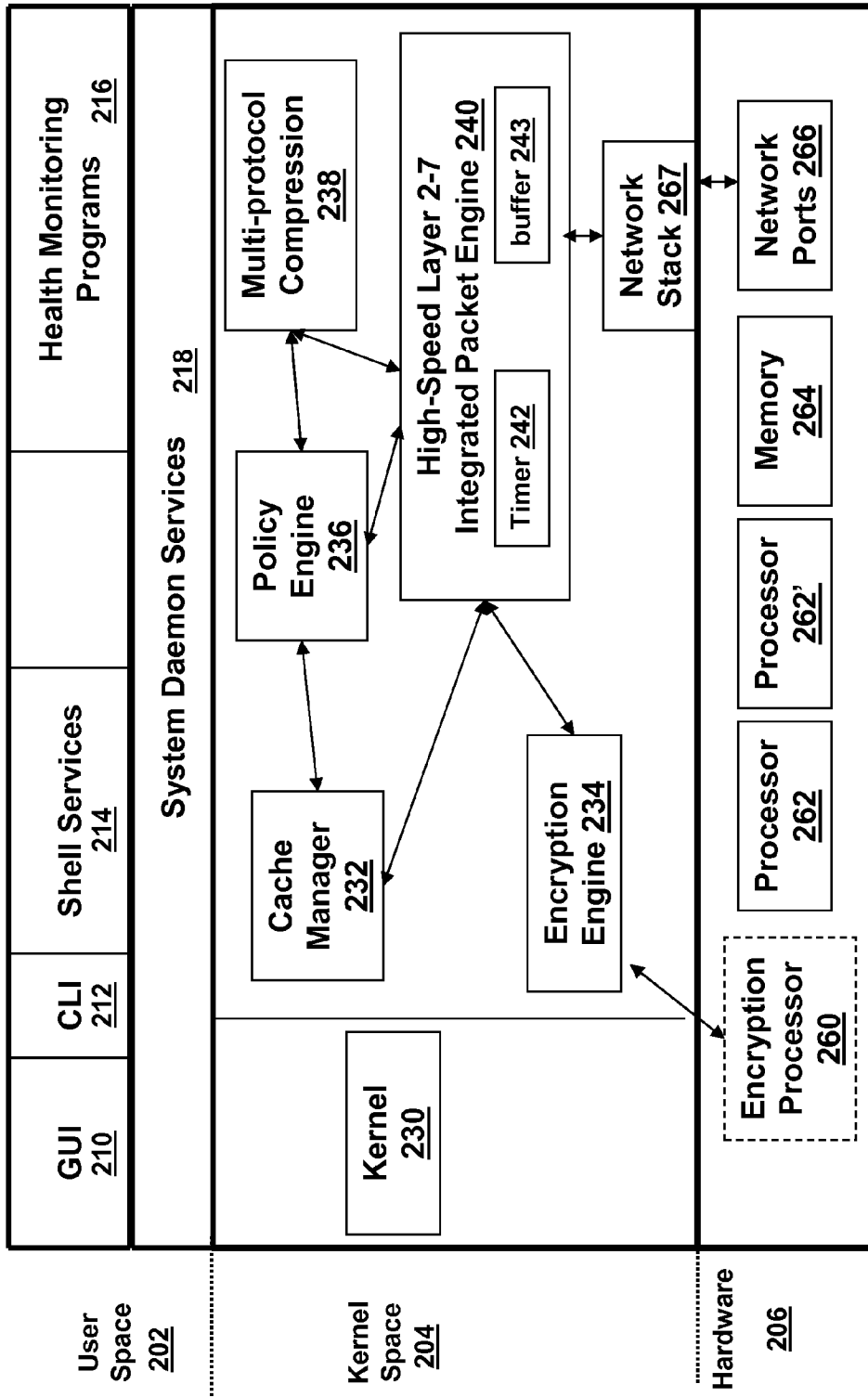
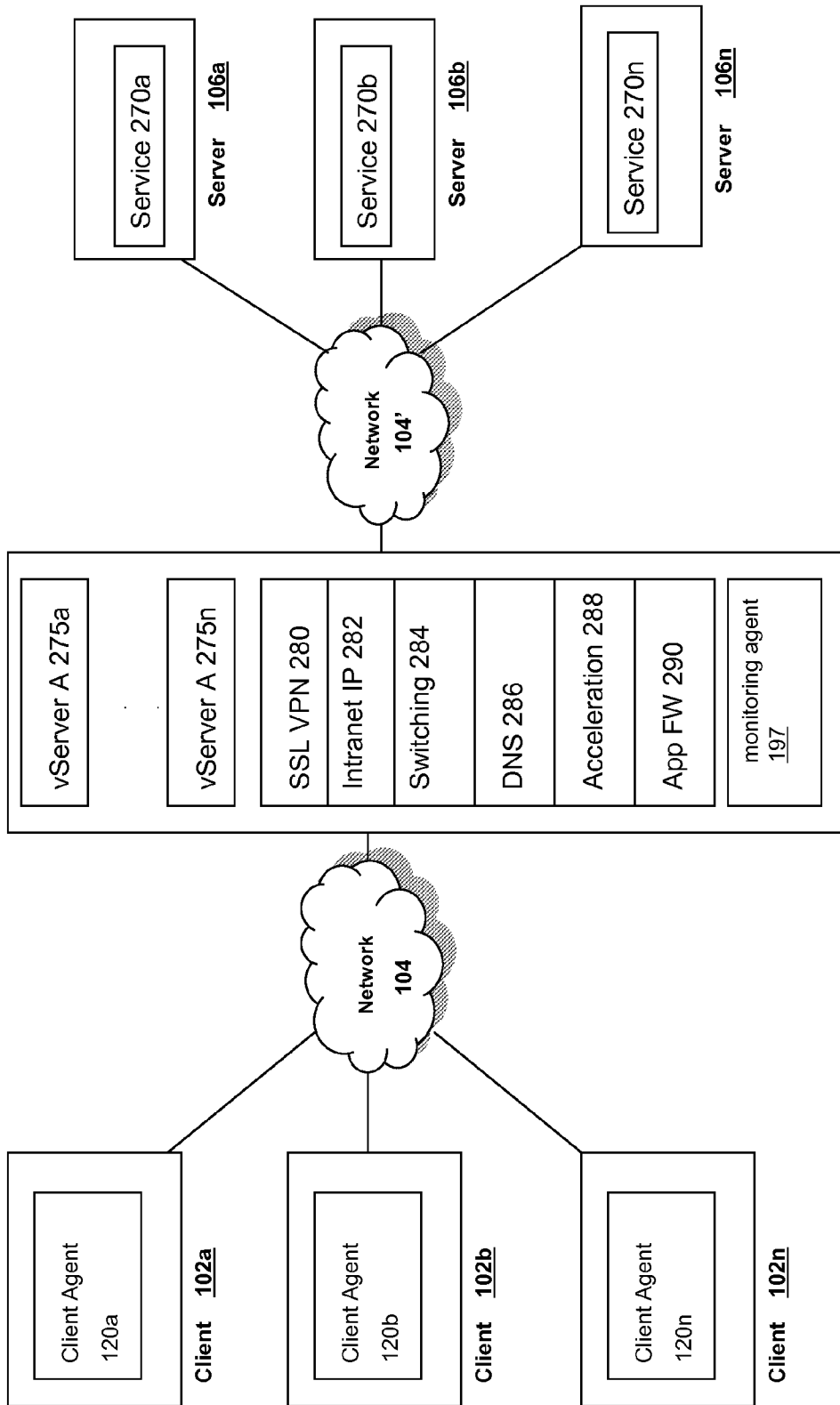
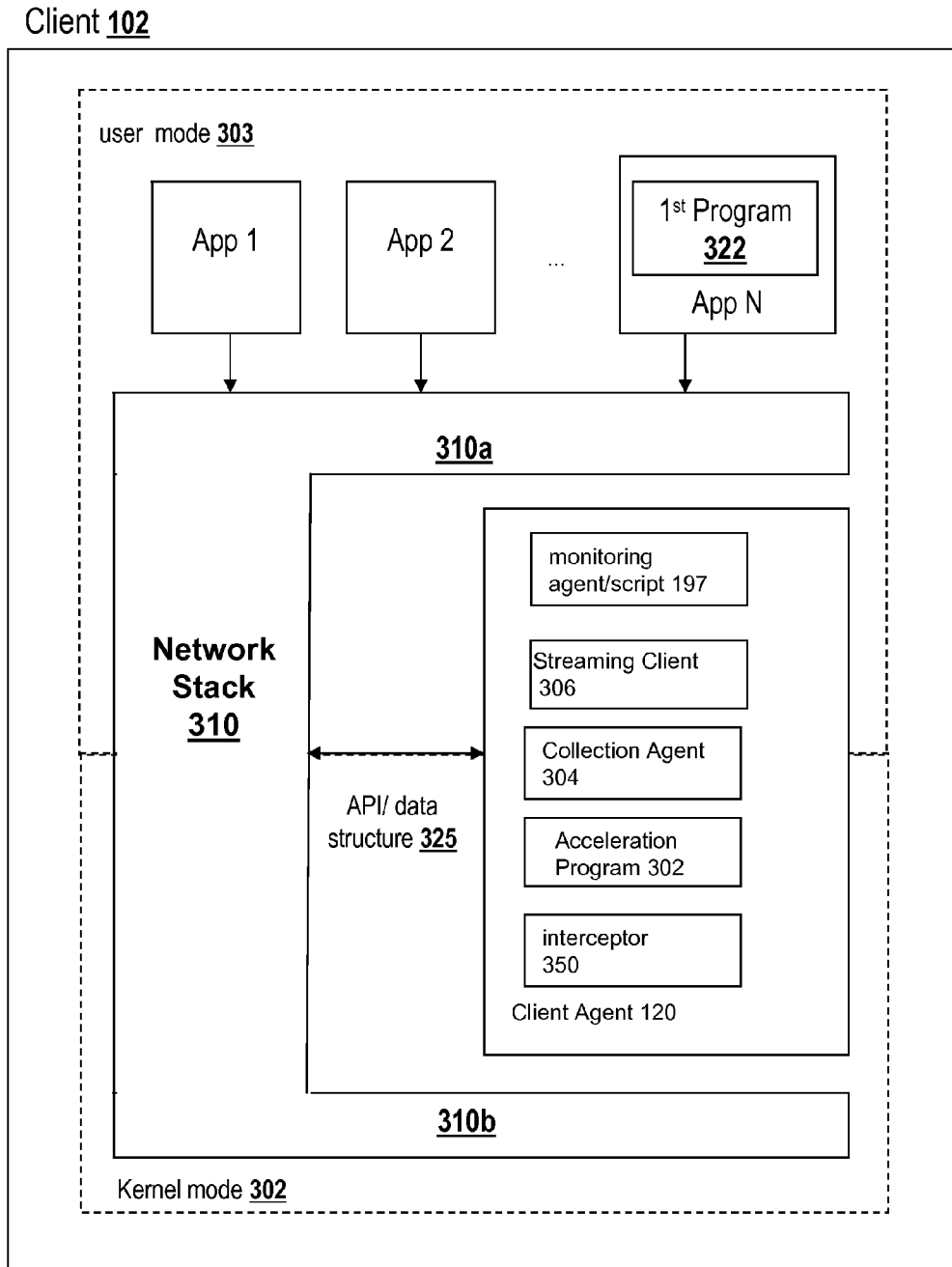

FIG. 2A



Appliance 200

FIG. 2B



100

Fig. 3

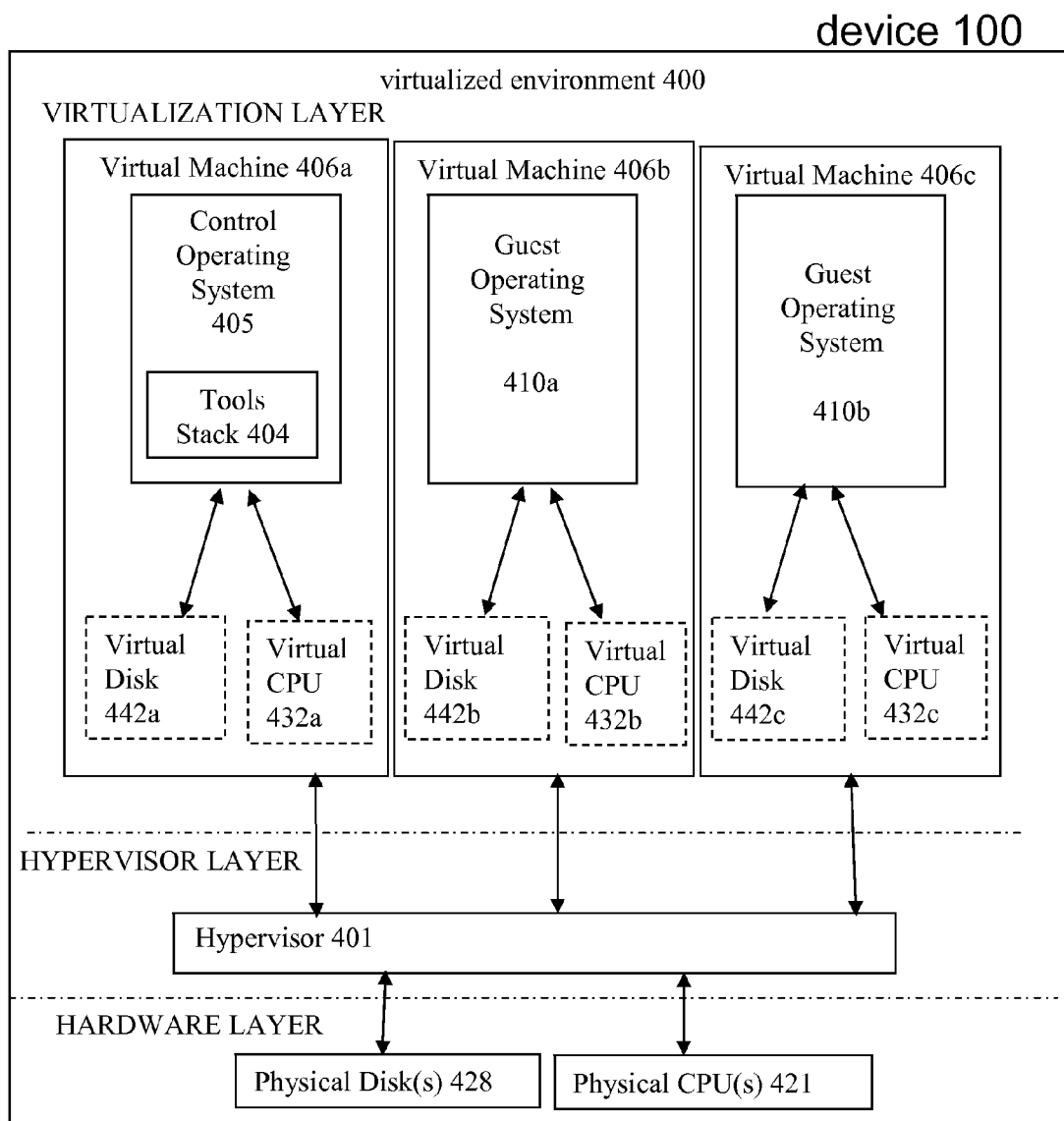

Fig. 4A

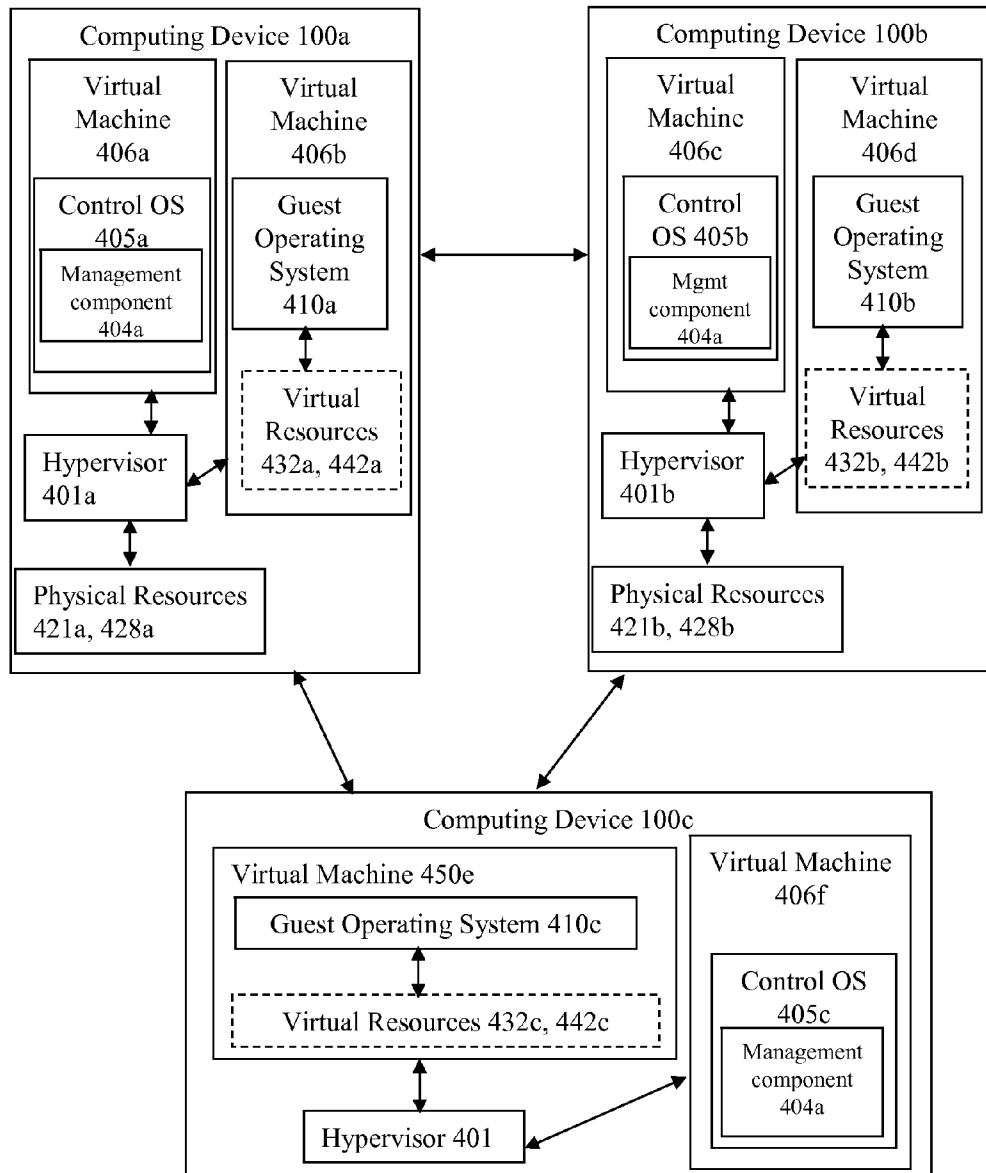
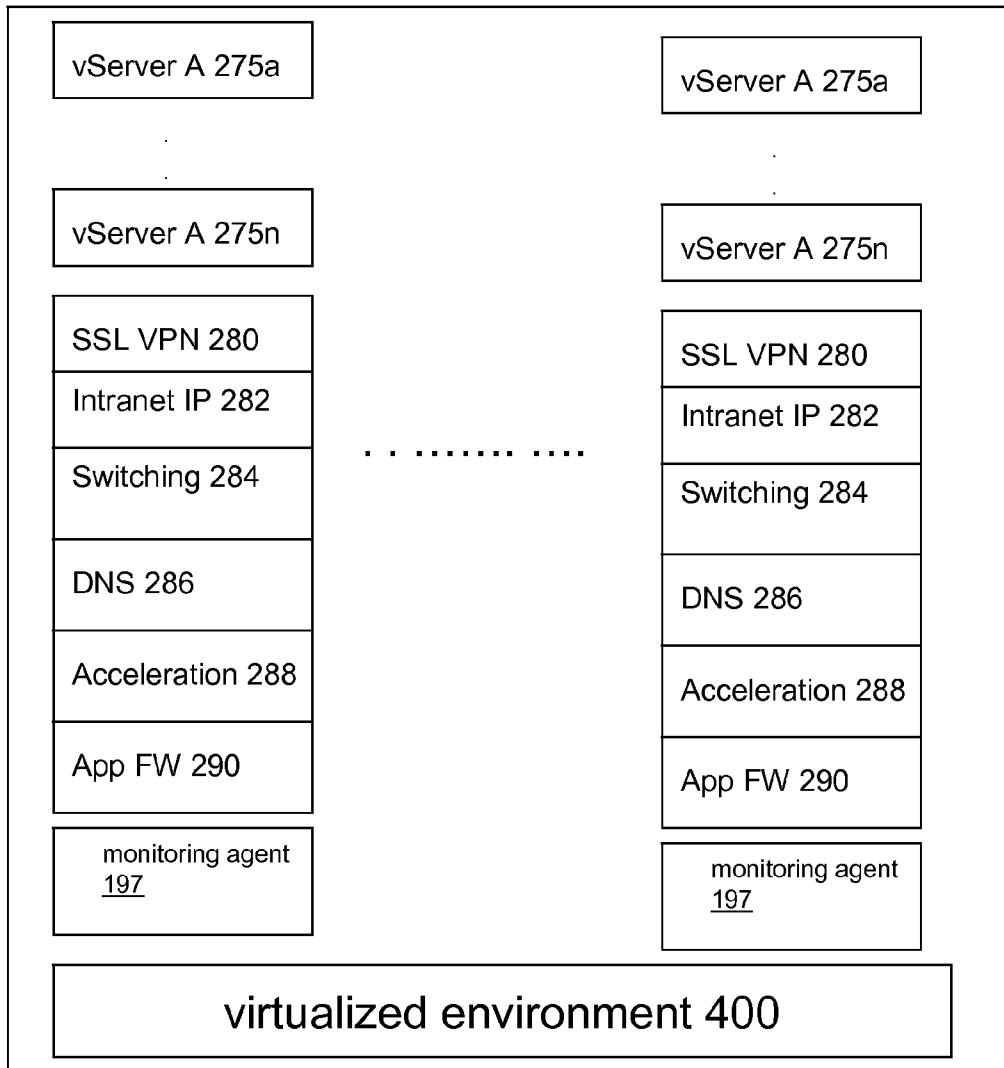

Fig. 4B

virtualized application delivery controller 450



computing device 100

Fig. 4C

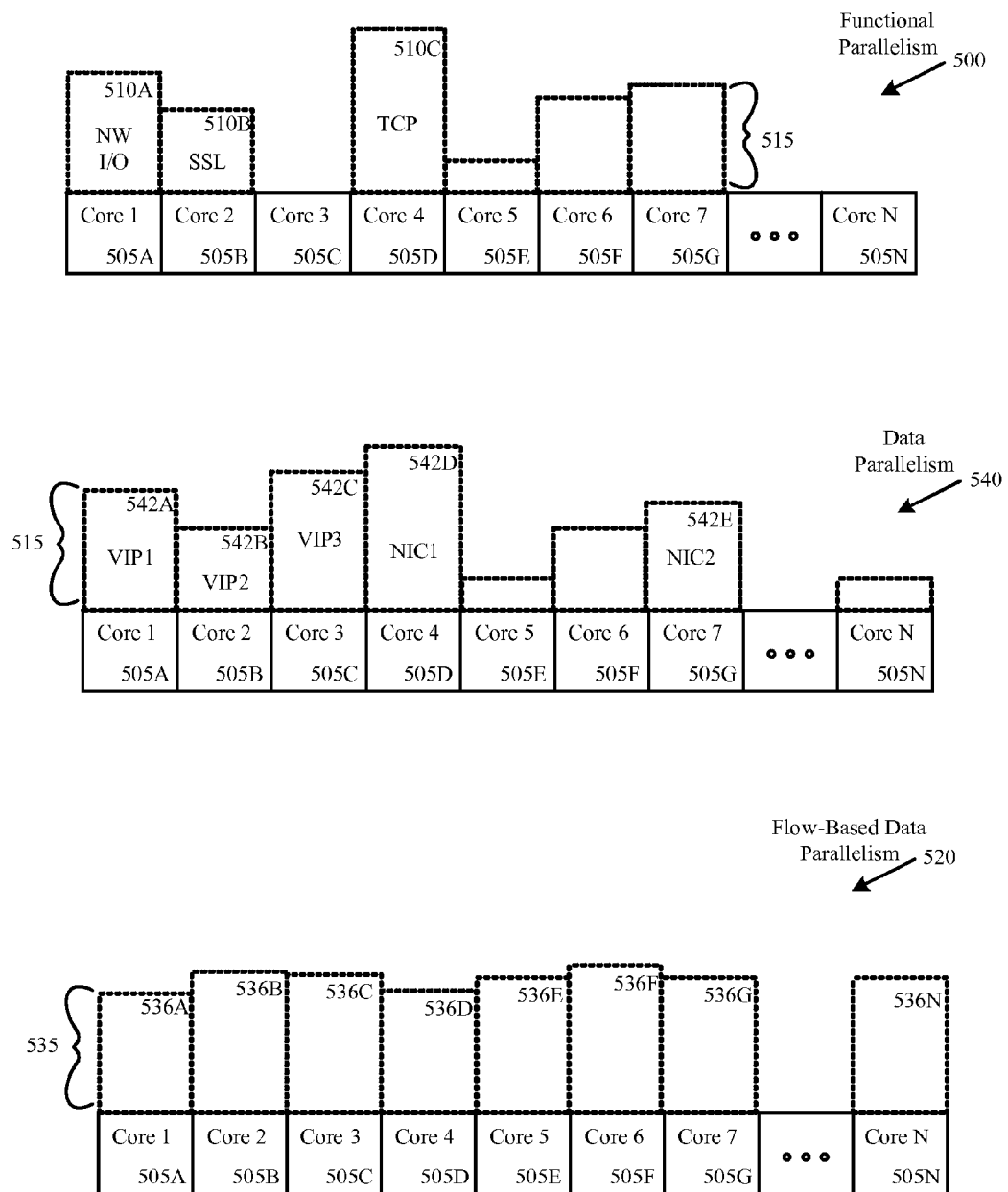

Fig. 5A

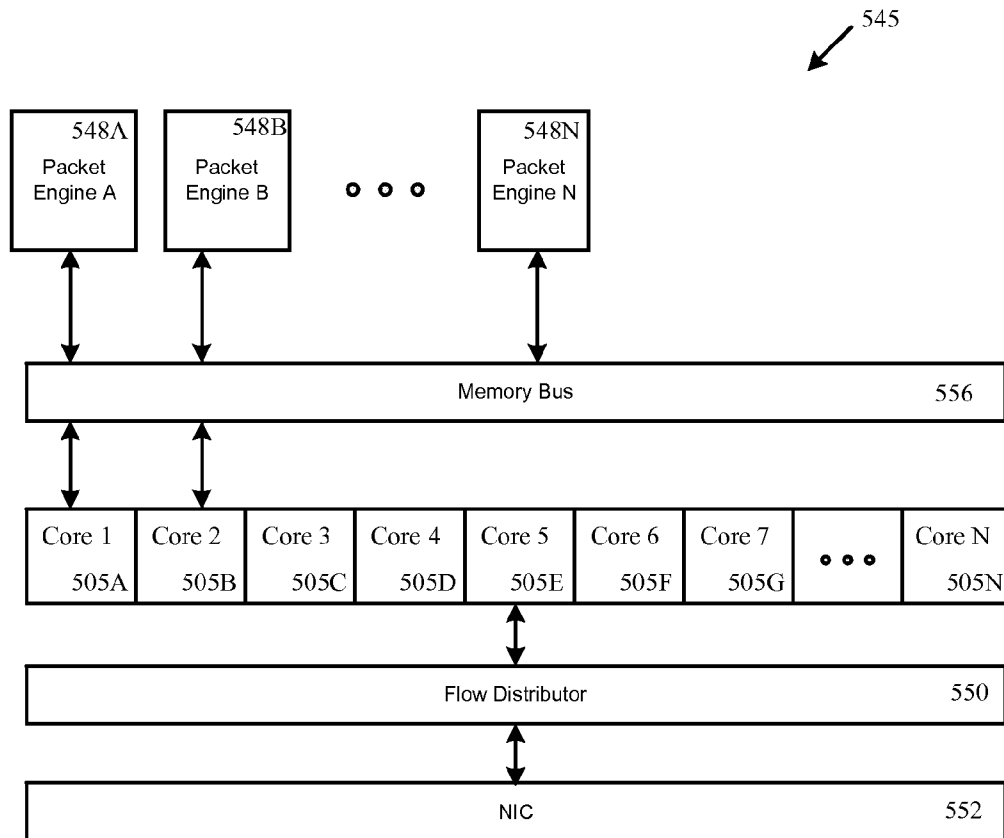

Fig. 5B

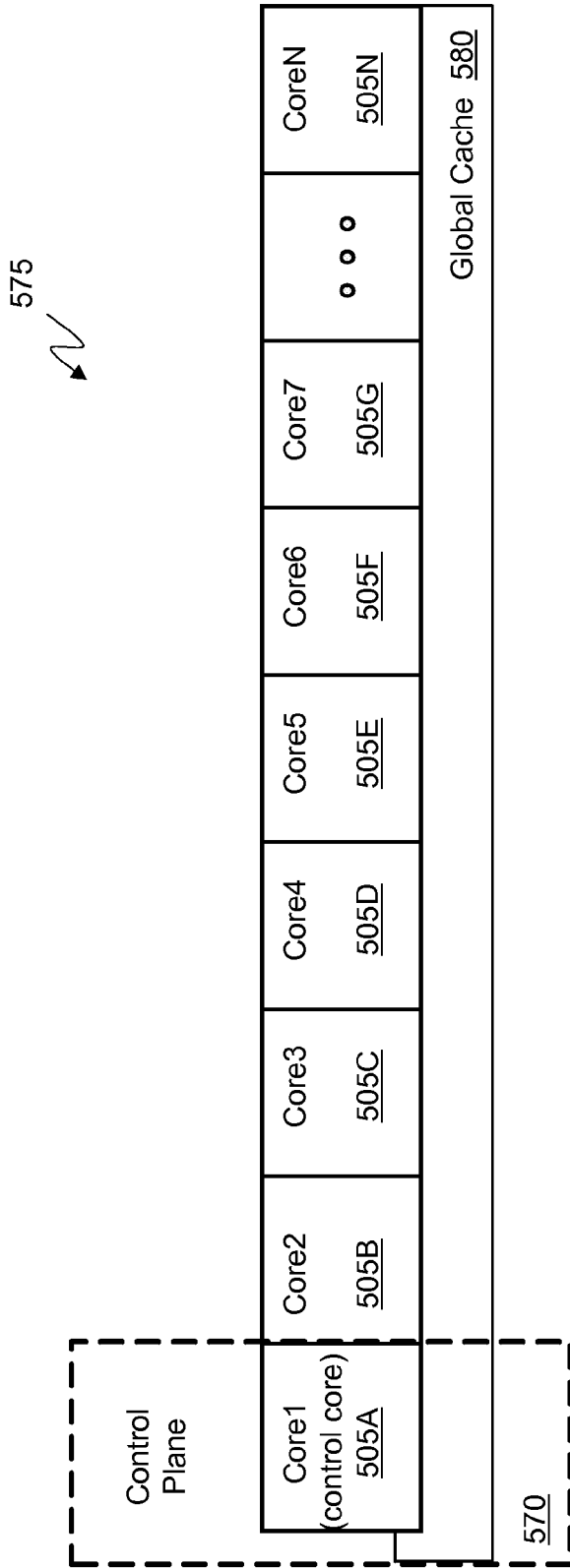

FIG. 5C

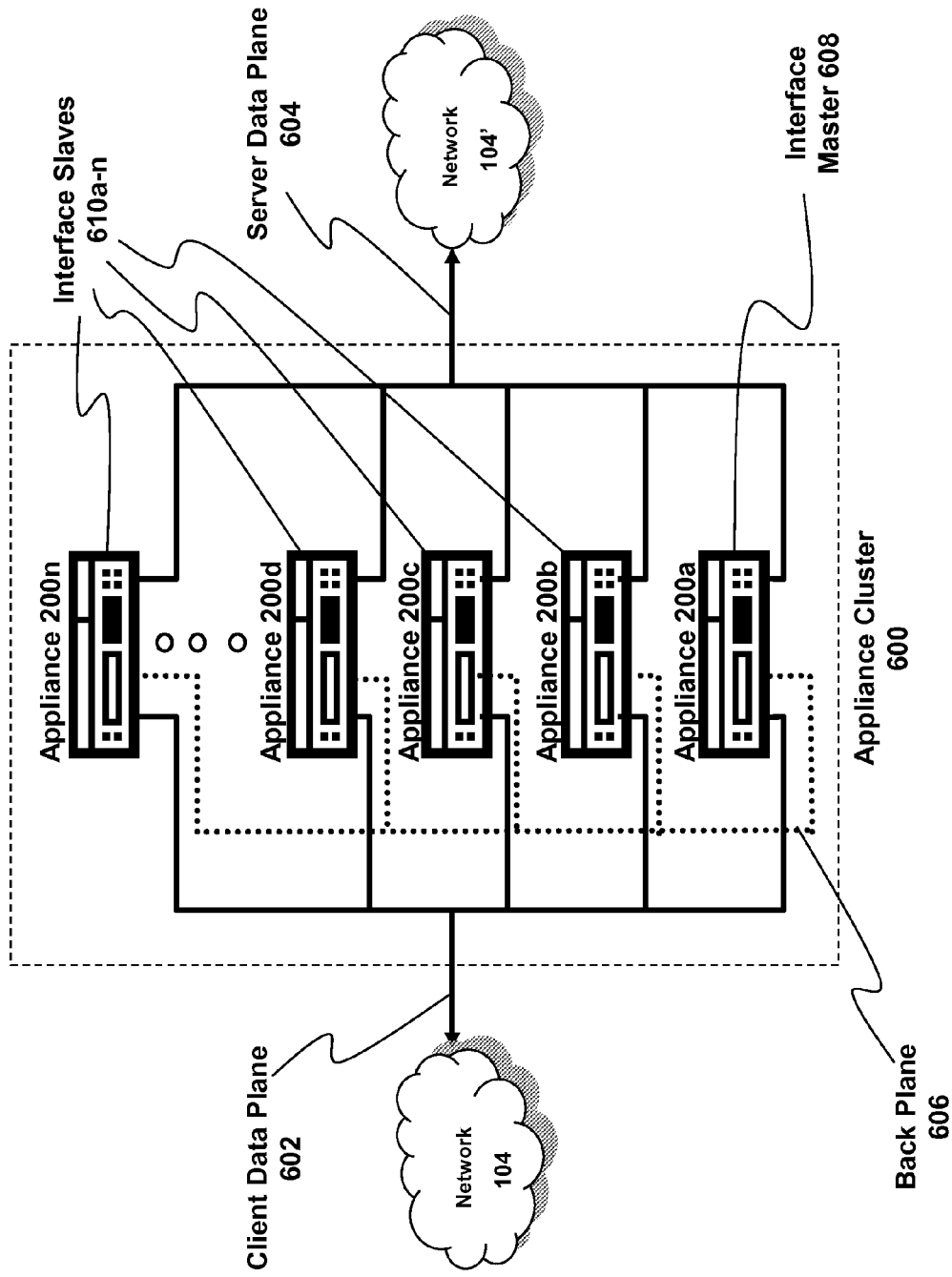

FIG. 6

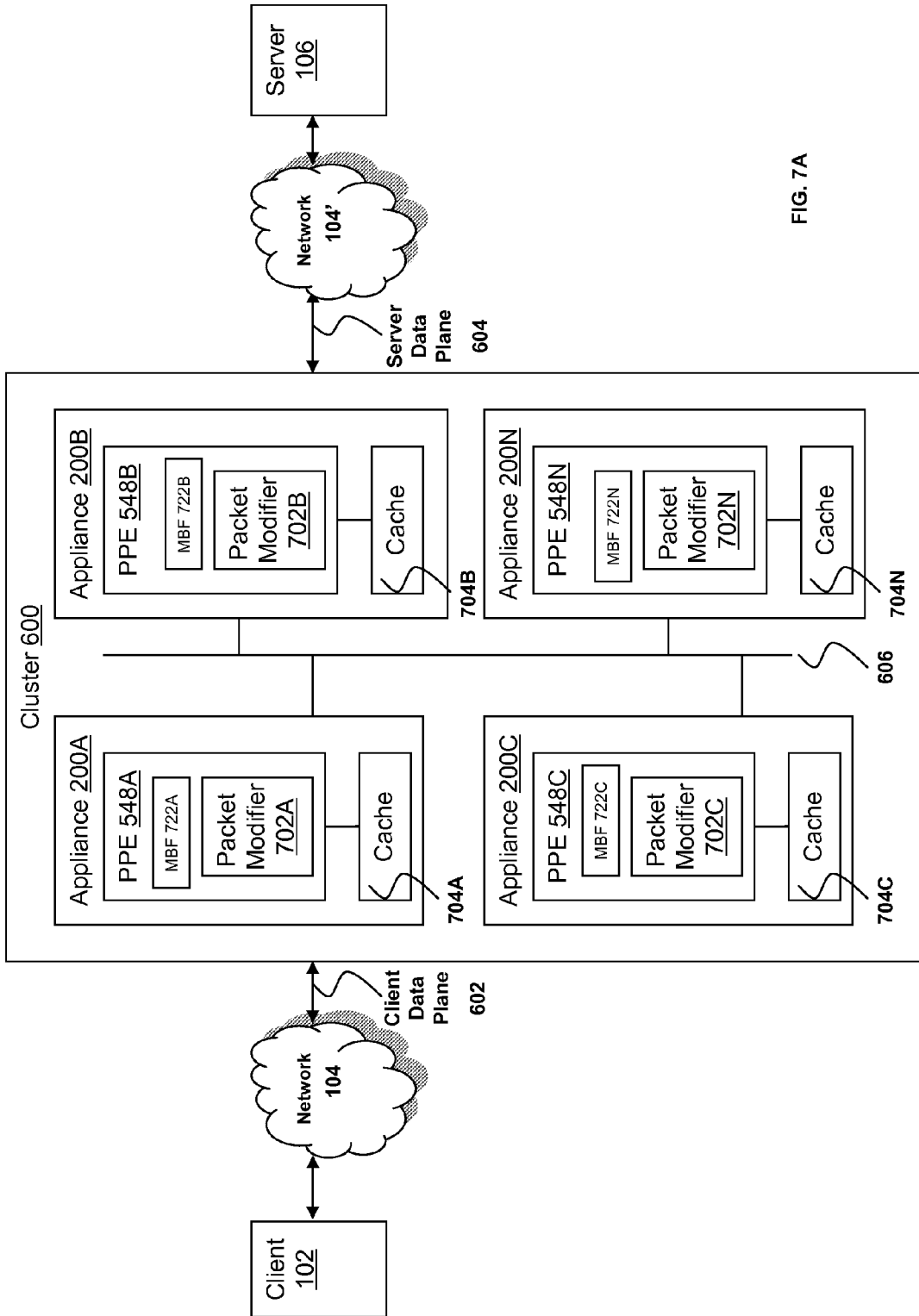

FIG. 7A

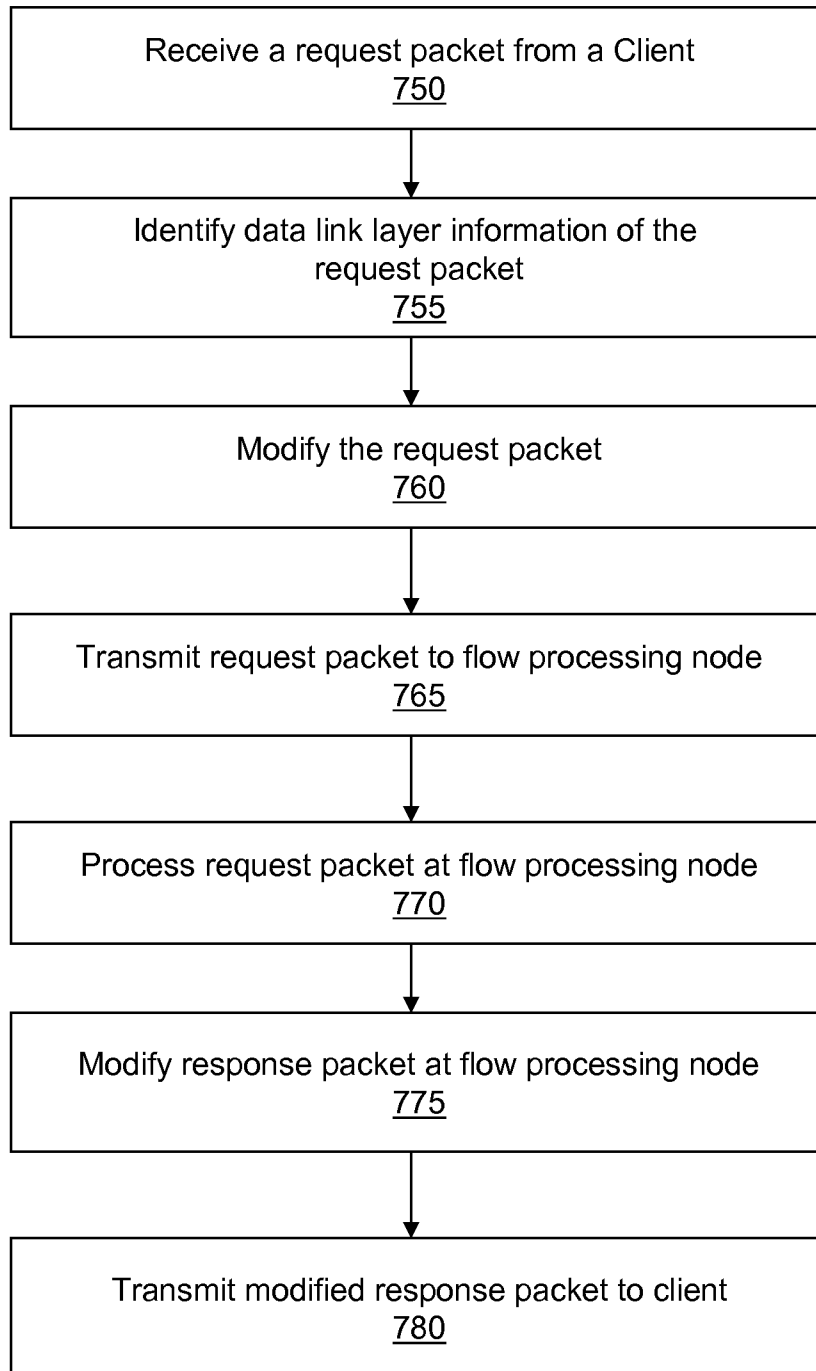

FIG. 7B

SYSTEMS AND METHODS FOR SHARING L2 INFORMATION AND MAC BASED FORWARDING

FIELD OF THE PRESENT DISCLOSURE

The present application generally relates to data communication networks. In particular, the present application relates to systems and methods for sharing data link layer information of network traffic distributed across a cluster of intermediary devices.

BACKGROUND

When a client communicates with a server through a cluster of intermediary devices, data link layer information of the transport packets may be changed by the intermediary devices to communicate with one another internally. This creates a challenging environment when one intermediary device communicates with the client and another intermediary device communicates with the server.

BRIEF SUMMARY OF THE PRESENT DISCLOSURE

In a clustered environment of nodes comprising intermediary devices between clients and servers, in some cases a node may not have the routing information for the clients. Thus, if an externally initiated connection comes from MAC A, then the response can be sent back to MAC A, without looking up for any routing information. When the traffic received by a flow received node is forwarded to a flow processor node, the layer 2 (L2) information is lost as the packet is routed to that node using current node layer 2 information. In those cases, the present solution exchanges the L2 information between the nodes, so that the flow processor knows the L2 context of the flow receiver. To resolve this, the L2 information like VLAN (virtual local area network), Interface and MAC are piggybacked to the traffic. The flow receiver gets the L2 context of the flow receiver from this L2 information. These packets are distinguished from the normal packets using a special MAC (Media Access Control).

If MAC Based Forwarding is enabled on the intermediary devices, the incoming L2 information (interface, source MAC and source VLAN) is cached and is used while forwarding the response. In a Cluster environments, when the flow receiver steers the traffic to the flow processor, the L2 information is lost. The present solution preserves this information either at the flow receiver or flow processor for Mac Based Forwarding. The flow receiver piggybacks the layer 2 information like VLAN, Interface and MAC, to the traffic. The flow processor on receiving this packet strips the L2 information and caches this. On the return path, when flow processor receives response from a server, the flow processor retrieves the cached information and tunnels the information back to the flow receiver. The flow receiver forwards the packet to the client using the tunneled information.

The present application is directed towards sharing data link layer information of network traffic distributed across a cluster of intermediary devices. In one aspect, a method for sharing data link layer information of network traffic distributed across a cluster of intermediary devices includes receiving a transport layer packet at a first intermediary device. The first intermediary device identifies a first set of data link layer information from a data link layer of the transport layer packet. The first intermediary device modifies the transport layer packet for transmission on a common data backplane of

the cluster to include the first set of data link layer information in the transport layer packet. The modified transport layer packet also includes a second set of data link layer information that is different from the first set of data link layer information at the data link layer. The first intermediary device transmits the modified transport layer packet on the common data backplane of the cluster to each of the other intermediary devices of the cluster.

In another aspect, a method for Media Access Control (MAC) based forwarding in a cluster of intermediary devices is provided. A first intermediary device identifies a Media Access Control (MAC) id at a data link layer of a transport layer packet of a request received by the first intermediary device. The first intermediary device transmits the transport layer packet on a common data backplane of the cluster to each of the other intermediary devices of the cluster. The transport layer packet is modified to include the MAC id and further includes a second MAC id that is different than the MAC id at the data link layer of the transport layer packet. A secondary intermediary device removes the MAC id from the transport layer packet received by the second intermediary device via the common data backplane of the cluster. The secondary intermediary device caches the MAC id to a cache of the second intermediary device and retrieves the MAC id from the cache in response to receiving a response to the request. The second intermediary device forwards the response modified to set the MAC id retrieved from the cache as the MAC id at the data link layer of one or more transport layer packets of the response.

The details of various embodiments of the present disclosure are set forth in the accompanying drawings and the description below.

BRIEF DESCRIPTION OF THE FIGURES

The foregoing and other objects, aspects, features, and advantages of the present disclosure will become more apparent and better understood by referring to the following description taken in conjunction with the accompanying drawings, in which:

FIG. 1A is a block diagram of an embodiment of a network environment for a client to access a server via an appliance;

FIG. 1B is a block diagram of an embodiment of an environment for delivering a computing environment from a server to a client via an appliance;

FIG. 1C is a block diagram of another embodiment of an environment for delivering a computing environment from a server to a client via an appliance;

FIG. 1D is a block diagram of another embodiment of an environment for delivering a computing environment from a server to a client via an appliance;

FIGS. 1E-1H are block diagrams of embodiments of a computing device;

FIG. 2A is a block diagram of an embodiment of an appliance for processing communications between a client and a server;

FIG. 2B is a block diagram of another embodiment of an appliance for optimizing, accelerating, load-balancing and routing communications between a client and a server;

FIG. 3 is a block diagram of an embodiment of a client for communicating with a server via the appliance;

FIG. 4A is a block diagram of an embodiment of a virtualization environment;

FIG. 4B is a block diagram of another embodiment of a virtualization environment;

FIG. 4C is a block diagram of an embodiment of a virtualized appliance;

FIG. 5A are block diagrams of embodiments of approaches to implementing parallelism in a multi-core system;

FIG. 5B is a block diagram of an embodiment of a system utilizing a multi-core system;

FIG. 5C is a block diagram of another embodiment of an aspect of a multi-core system;

FIG. 6 is a block diagram of an embodiment of a cluster system;

FIG. 7A is a block diagram of an embodiment of a system of sharing data link layer information in a clustered environment; and

FIG. 7B is a flow diagram of an embodiment of a method of sharing data link layer information.

The features and advantages of the present disclosure will become more apparent from the detailed description set forth below when taken in conjunction with the drawings, in which like reference characters identify corresponding elements throughout. In the drawings, like reference numbers generally indicate identical, functionally similar, and/or structurally similar elements.

DETAILED DESCRIPTION OF THE PRESENT DISCLOSURE

For purposes of reading the description of the various embodiments below, the following descriptions of the sections of the specification and their respective contents may be helpful:

Section A describes a network environment and computing environment which may be useful for practicing embodiments described herein;

Section B describes embodiments of systems and methods for delivering a computing environment to a remote user;

Section C describes embodiments of systems and methods for accelerating communications between a client and a server;

Section D describes embodiments of systems and methods for virtualizing an application delivery controller;

Section E describes embodiments of systems and methods for providing a multi-core architecture and environment;

Section F describes embodiments of systems and methods for providing a clustered appliance architecture environment; and

Section G describes embodiments of systems and methods for sharing data link layer information of network traffic distributed across a cluster of intermediary devices.

A. Network and Computing Environment

Prior to discussing the specifics of embodiments of the systems and methods of an appliance and/or client, it may be helpful to discuss the network and computing environments in which such embodiments may be deployed. Referring now to FIG. 1A, an embodiment of a network environment is depicted. In brief overview, the network environment comprises one or more clients **102a-102n** (also generally referred to as local machine(s) **102**, or client(s) **102**) in communication with one or more servers **106a-106n** (also generally referred to as server(s) **106**, or remote machine(s) **106**) via one or more networks **104, 104'** (generally referred to as network **104**). In some embodiments, a client **102** communicates with a server **106** via an appliance **200**.

Although FIG. 1A shows a network **104** and a network **104'** between the clients **102** and the servers **106**, the clients **102** and the servers **106** may be on the same network **104**. The networks **104** and **104'** can be the same type of network or different types of networks. The network **104** and/or the network **104'** can be a local-area network (LAN), such as a

company Intranet, a metropolitan area network (MAN), or a wide area network (WAN), such as the Internet or the World Wide Web. In one embodiment, network **104'** may be a private network and network **104** may be a public network. In some embodiments, network **104** may be a private network and network **104'** a public network. In another embodiment, networks **104** and **104'** may both be private networks. In some embodiments, clients **102** may be located at a branch office of a corporate enterprise communicating via a WAN connection over the network **104** to the servers **106** located at a corporate data center.

The network **104** and/or **104'** be any type and/or form of network and may include any of the following: a point to point network, a broadcast network, a wide area network, a local area network, a telecommunications network, a data communication network, a computer network, an ATM (Asynchronous Transfer Mode) network, a SONET (Synchronous Optical Network) network, a SDH (Synchronous Digital Hierarchy) network, a wireless network and a wireline network. In some embodiments, the network **104** may comprise a wireless link, such as an infrared channel or satellite band. The topology of the network **104** and/or **104'** may be a bus, star, or ring network topology. The network **104** and/or **104'** and network topology may be of any such network or network topology as known to those ordinarily skilled in the art capable of supporting the operations described herein.

As shown in FIG. 1A, the appliance **200**, which also may be referred to as an interface unit **200** or gateway **200**, is shown between the networks **104** and **104'**. In some embodiments, the appliance **200** may be located on network **104**. For example, a branch office of a corporate enterprise may deploy an appliance **200** at the branch office. In other embodiments, the appliance **200** may be located on network **104'**. For example, an appliance **200** may be located at a corporate data center. In yet another embodiment, a plurality of appliances **200** may be deployed on network **104**. In some embodiments, e.g., as shown in FIGS. 1A-1D, a plurality of appliances **200** may be deployed on network **104'**. In one embodiment, a first appliance **200** communicates with a second appliance **200'**. In other embodiments, the appliance **200** could be a part of any client **102** or server **106** on the same or different network **104, 104'** as the client **102**. One or more appliances **200** may be located at any point in the network or network communications path between a client **102** and a server **106**.

In some embodiments, the appliance **200** comprises any of the network devices manufactured by Citrix Systems, Inc. of Ft. Lauderdale Fla., referred to as Citrix NetScaler devices. In other embodiments, the appliance **200** includes any of the product embodiments referred to as WebAccelerator and BigIP manufactured by F5 Networks, Inc. of Seattle, Wash. In another embodiment, the appliance **205** includes any of the DX acceleration device platforms and/or the SSL VPN series of devices, such as SA 200, SA 2000, SA 4000, and SA 6000 devices manufactured by Juniper Networks, Inc. of Sunnyvale, Calif. In yet another embodiment, the appliance **200** includes any application acceleration and/or security related appliances and/or software manufactured by Cisco Systems, Inc. of San Jose, Calif., such as the Cisco ACE Application Control Engine Module service software and network modules, and Cisco AVS Series Application Velocity System.

In one embodiment, the system may include multiple, logically-grouped servers **106**. In these embodiments, the logical group of servers may be referred to as a server farm **38**. In some of these embodiments, the servers **106** may be geographically dispersed. In some cases, a farm **38** may be administered as a single entity. In other embodiments, the server farm **38** comprises a plurality of server farms **38**. In one

embodiment, the server farm executes one or more applications on behalf of one or more clients **102**.

The servers **106** within each farm **38** can be heterogeneous. One or more of the servers **106** can operate according to one type of operating system platform (e.g., WINDOWS NT, manufactured by Microsoft Corp. of Redmond, Wash.), while one or more of the other servers **106** can operate on according to another type of operating system platform (e.g., Unix or Linux). The servers **106** of each farm **38** do not need to be physically proximate to another server **106** in the same farm **38**. Thus, the group of servers **106** logically grouped as a farm **38** may be interconnected using a wide-area network (WAN) connection or medium-area network (MAN) connection. For example, a farm **38** may include servers **106** physically located in different continents or different regions of a continent, country, state, city, campus, or room. Data transmission speeds between servers **106** in the farm **38** can be increased if the servers **106** are connected using a local-area network (LAN) connection or some form of direct connection.

Servers **106** may be referred to as a file server, application server, web server, proxy server, or gateway server. In some embodiments, a server **106** may have the capacity to function as either an application server or as a master application server. In one embodiment, a server **106** may include an Active Directory. The clients **102** may also be referred to as client nodes or endpoints. In some embodiments, a client **102** has the capacity to function as both a client node seeking access to applications on a server and as an application server providing access to hosted applications for other clients **102a-102n**.

In some embodiments, a client **102** communicates with a server **106**. In one embodiment, the client **102** communicates directly with one of the servers **106** in a farm **38**. In another embodiment, the client **102** executes a program neighborhood application to communicate with a server **106** in a farm **38**. In still another embodiment, the server **106** provides the functionality of a master node. In some embodiments, the client **102** communicates with the server **106** in the farm **38** through a network **104**. Over the network **104**, the client **102** can, for example, request execution of various applications hosted by the servers **106a-106n** in the farm **38** and receive output of the results of the application execution for display. In some embodiments, only the master node provides the functionality required to identify and provide address information associated with a server **106'** hosting a requested application.

In one embodiment, the server **106** provides functionality of a web server. In another embodiment, the server **106a** receives requests from the client **102**, forwards the requests to a second server **106b** and responds to the request by the client **102** with a response to the request from the server **106b**. In still another embodiment, the server **106** acquires an enumeration of applications available to the client **102** and address information associated with a server **106** hosting an application identified by the enumeration of applications. In yet another embodiment, the server **106** presents the response to the request to the client **102** using a web interface. In one embodiment, the client **102** communicates directly with the server **106** to access the identified application. In another embodiment, the client **102** receives application output data, such as display data, generated by an execution of the identified application on the server **106**.

Referring now to FIG. 1B, an embodiment of a network environment deploying multiple appliances **200** is depicted. A first appliance **200** may be deployed on a first network **104** and a second appliance **200'** on a second network **104'**. For example a corporate enterprise may deploy a first appliance

200 at a branch office and a second appliance **200'** at a data center. In another embodiment, the first appliance **200** and second appliance **200'** are deployed on the same network **104** or network **104'**. For example, a first appliance **200** may be deployed for a first server farm **38**, and a second appliance **200** may be deployed for a second server farm **38'**. In another example, a first appliance **200** may be deployed at a first branch office while the second appliance **200'** is deployed at a second branch office'. In some embodiments, the first appliance **200** and second appliance **200'** work in cooperation or in conjunction with each other to accelerate network traffic or the delivery of application and data between a client and a server

Referring now to FIG. 1C, another embodiment of a network environment deploying the appliance **200** with one or more other types of appliances, such as between one or more WAN optimization appliance **205, 205'** is depicted. For example a first WAN optimization appliance **205** is shown between networks **104** and **104'** and a second WAN optimization appliance **205'** may be deployed between the appliance **200** and one or more servers **106**. By way of example, a corporate enterprise may deploy a first WAN optimization appliance **205** at a branch office and a second WAN optimization appliance **205'** at a data center. In some embodiments, the appliance **205** may be located on network **104'**. In other embodiments, the appliance **205'** may be located on network **104**. In some embodiments, the appliance **205'** may be located on network **104'** or network **104''**. In one embodiment, the appliance **205** and **205'** are on the same network. In another embodiment, the appliance **205** and **205'** are on different networks. In another example, a first WAN optimization appliance **205** may be deployed for a first server farm **38** and a second WAN optimization appliance **205'** for a second server farm **38'**

In one embodiment, the appliance **205** is a device for accelerating, optimizing or otherwise improving the performance, operation, or quality of service of any type and form of network traffic, such as traffic to and/or from a WAN connection. In some embodiments, the appliance **205** is a performance enhancing proxy. In other embodiments, the appliance **205** is any type and form of WAN optimization or acceleration device, sometimes also referred to as a WAN optimization controller. In one embodiment, the appliance **205** is any of the product embodiments referred to as WANScaler manufactured by Citrix Systems, Inc. of Ft. Lauderdale, Fla. In other embodiments, the appliance **205** includes any of the product embodiments referred to as BIG-IP link controller and WANjet manufactured by F5 Networks, Inc. of Seattle, Wash. In another embodiment, the appliance **205** includes any of the WX and WXC WAN acceleration device platforms manufactured by Juniper Networks, Inc. of Sunnyvale, Calif. In some embodiments, the appliance **205** includes any of the steelhead line of WAN optimization appliances manufactured by Riverbed Technology of San Francisco, Calif. In other embodiments, the appliance **205** includes any of the WAN related devices manufactured by Expand Networks Inc. of Roseland, N.J. In one embodiment, the appliance **205** includes any of the WAN related appliances manufactured by Packeteer Inc. of Cupertino, Calif., such as the PacketShaper, iShared, and SkyX product embodiments provided by Packeteer. In yet another embodiment, the appliance **205** includes any WAN related appliances and/or software manufactured by Cisco Systems, Inc. of San Jose, Calif., such as the Cisco Wide Area Network Application Services software and network modules, and Wide Area Network engine appliances.

In one embodiment, the appliance **205** provides application and data acceleration services for branch-office or remote

offices. In one embodiment, the appliance **205** includes optimization of Wide Area File Services (WAFS). In another embodiment, the appliance **205** accelerates the delivery of files, such as via the Common Internet File System (CIFS) protocol. In other embodiments, the appliance **205** provides caching in memory and/or storage to accelerate delivery of applications and data. In one embodiment, the appliance **205** provides compression of network traffic at any level of the network stack or at any protocol or network layer. In another embodiment, the appliance **205** provides transport layer protocol optimizations, flow control, performance enhancements or modifications and/or management to accelerate delivery of applications and data over a WAN connection. For example, in one embodiment, the appliance **205** provides Transport Control Protocol (TCP) optimizations. In other embodiments, the appliance **205** provides optimizations, flow control, performance enhancements or modifications and/or management for any session or application layer protocol.

In another embodiment, the appliance **205** encoded any type and form of data or information into custom or standard TCP and/or IP header fields or option fields of network packet to announce presence, functionality or capability to another appliance **205'**. In another embodiment, an appliance **205'** may communicate with another appliance **205'** using data encoded in both TCP and/or IP header fields or options. For example, the appliance may use TCP option(s) or IP header fields or options to communicate one or more parameters to be used by the appliances **205**, **205'** in performing functionality, such as WAN acceleration, or for working in conjunction with each other.

In some embodiments, the appliance **200** preserves any of the information encoded in TCP and/or IP header and/or option fields communicated between appliances **205** and **205'**. For example, the appliance **200** may terminate a transport layer connection traversing the appliance **200**, such as a transport layer connection from between a client and a server traversing appliances **205** and **205'**. In one embodiment, the appliance **200** identifies and preserves any encoded information in a transport layer packet transmitted by a first appliance **205** via a first transport layer connection and communicates a transport layer packet with the encoded information to a second appliance **205'** via a second transport layer connection.

Referring now to FIG. 1D, a network environment for delivering and/or operating a computing environment on a client **102** is depicted. In some embodiments, a server **106** includes an application delivery system **190** for delivering a computing environment or an application and/or data file to one or more clients **102**. In brief overview, a client **102** is in communication with a server **106** via network **104**, **104'** and appliance **200**. For example, the client **102** may reside in a remote office of a company, e.g., a branch office, and the server **106** may reside at a corporate data center. The client **102** comprises a client agent **120**, and a computing environment **15**. The computing environment **15** may execute or operate an application that accesses, processes or uses a data file. The computing environment **15**, application and/or data file may be delivered via the appliance **200** and/or the server **106**.

In some embodiments, the appliance **200** accelerates delivery of a computing environment **15**, or any portion thereof, to a client **102**. In one embodiment, the appliance **200** accelerates the delivery of the computing environment **15** by the application delivery system **190**. For example, the embodiments described herein may be used to accelerate delivery of a streaming application and data file processable by the application from a central corporate data center to a remote user

location, such as a branch office of the company. In another embodiment, the appliance **200** accelerates transport layer traffic between a client **102** and a server **106**. The appliance **200** may provide acceleration techniques for accelerating any transport layer payload from a server **106** to a client **102**, such as: 1) transport layer connection pooling, 2) transport layer connection multiplexing, 3) transport control protocol buffering, 4) compression and 5) caching. In some embodiments, the appliance **200** provides load balancing of servers **106** in responding to requests from clients **102**. In other embodiments, the appliance **200** acts as a proxy or access server to provide access to the one or more servers **106**. In another embodiment, the appliance **200** provides a secure virtual private network connection from a first network **104** of the client **102** to the second network **104'** of the server **106**, such as an SSL VPN connection. In yet other embodiments, the appliance **200** provides application firewall security, control and management of the connection and communications between a client **102** and a server **106**.

In some embodiments, the application delivery management system **190** provides application delivery techniques to deliver a computing environment to a desktop of a user, remote or otherwise, based on a plurality of execution methods and based on any authentication and authorization policies applied via a policy engine **195**. With these techniques, a remote user may obtain a computing environment and access to server stored applications and data files from any network connected device **100**. In one embodiment, the application delivery system **190** may reside or execute on a server **106**. In another embodiment, the application delivery system **190** may reside or execute on a plurality of servers **106a-106n**. In some embodiments, the application delivery system **190** may execute in a server farm **38**. In one embodiment, the server **106** executing the application delivery system **190** may also store or provide the application and data file. In another embodiment, a first set of one or more servers **106** may execute the application delivery system **190**, and a different server **106n** may store or provide the application and data file. In some embodiments, each of the application delivery system **190**, the application, and data file may reside or be located on different servers. In yet another embodiment, any portion of the application delivery system **190** may reside, execute or be stored on or distributed to the appliance **200**, or a plurality of appliances.

The client **102** may include a computing environment **15** for executing an application that uses or processes a data file. The client **102** via networks **104**, **104'** and appliance **200** may request an application and data file from the server **106**. In one embodiment, the appliance **200** may forward a request from the client **102** to the server **106**. For example, the client **102** may not have the application and data file stored or accessible locally. In response to the request, the application delivery system **190** and/or server **106** may deliver the application and data file to the client **102**. For example, in one embodiment, the server **106** may transmit the application as an application stream to operate in computing environment **15** on client **102**.

In some embodiments, the application delivery system **190** comprises any portion of the Citrix Access Suite™ by Citrix Systems, Inc., such as the MetaFrame or Citrix Presentation Server™ and/or any of the Microsoft® Windows Terminal Services manufactured by the Microsoft Corporation. In one embodiment, the application delivery system **190** may deliver one or more applications to clients **102** or users via a remote-display protocol or otherwise via remote-based or server-based computing. In another embodiment, the application delivery system **190** may deliver one or more applications to clients or users via streaming of the application.

In one embodiment, the application delivery system **190** includes a policy engine **195** for controlling and managing the access to, selection of application execution methods and the delivery of applications. In some embodiments, the policy engine **195** determines the one or more applications a user or client **102** may access. In another embodiment, the policy engine **195** determines how the application should be delivered to the user or client **102**, e.g., the method of execution. In some embodiments, the application delivery system **190** provides a plurality of delivery techniques from which to select a method of application execution, such as a server-based computing, streaming or delivering the application locally to the client **120** for local execution.

In one embodiment, a client **102** requests execution of an application program and the application delivery system **190** comprising a server **106** selects a method of executing the application program. In some embodiments, the server **106** receives credentials from the client **102**. In another embodiment, the server **106** receives a request for an enumeration of available applications from the client **102**. In one embodiment, in response to the request or receipt of credentials, the application delivery system **190** enumerates a plurality of application programs available to the client **102**. The application delivery system **190** receives a request to execute an enumerated application. The application delivery system **190** selects one of a predetermined number of methods for executing the enumerated application, for example, responsive to a policy of a policy engine. The application delivery system **190** may select a method of execution of the application enabling the client **102** to receive application-output data generated by execution of the application program on a server **106**. The application delivery system **190** may select a method of execution of the application enabling the local machine **10** to execute the application program locally after retrieving a plurality of application files comprising the application. In yet another embodiment, the application delivery system **190** may select a method of execution of the application to stream the application via the network **104** to the client **102**.

A client **102** may execute, operate or otherwise provide an application, which can be any type and/or form of software, program, or executable instructions such as any type and/or form of web browser, web-based client, client-server application, a thin-client computing client, an ActiveX control, or a Java applet, or any other type and/or form of executable instructions capable of executing on client **102**. In some embodiments, the application may be a server-based or a remote-based application executed on behalf of the client **102** on a server **106**. In one embodiment the server **106** may display output to the client **102** using any thin-client or remote-display protocol, such as the Independent Computing Architecture (ICA) protocol manufactured by Citrix Systems, Inc. of Ft. Lauderdale, Fla. or the Remote Desktop Protocol (RDP) manufactured by the Microsoft Corporation of Redmond, Wash. The application can use any type of protocol and it can be, for example, an HTTP client, an FTP client, an Oscar client, or a Telnet client. In other embodiments, the application comprises any type of software related to VoIP communications, such as a soft IP telephone. In further embodiments, the application comprises any application related to real-time data communications, such as applications for streaming video and/or audio.

In some embodiments, the server **106** or a server farm **38** may be running one or more applications, such as an application providing a thin-client computing or remote display presentation application. In one embodiment, the server **106** or server farm **38** executes as an application, any portion of

the Citrix Access Suite™ by Citrix Systems, Inc., such as the MetaFrame or Citrix Presentation Server™, and/or any of the Microsoft® Windows Terminal Services manufactured by the Microsoft Corporation. In one embodiment, the application is an ICA client, developed by Citrix Systems, Inc. of Fort Lauderdale, Fla. In other embodiments, the application includes a Remote Desktop (RDP) client, developed by Microsoft Corporation of Redmond, Wash. Also, the server **106** may run an application, which for example, may be an application server providing email services such as Microsoft Exchange manufactured by the Microsoft Corporation of Redmond, Wash., a web or Internet server, or a desktop sharing server, or a collaboration server. In some embodiments, any of the applications may comprise any type of hosted service or products, such as GoToMeeting™ provided by Citrix Online Division, Inc. of Santa Barbara, Calif., WebEx™ provided by WebEx, Inc. of Santa Clara, Calif., or Microsoft Office Live Meeting provided by Microsoft Corporation of Redmond, Wash.

Still referring to FIG. 1D, an embodiment of the network environment may include a monitoring server **106A**. The monitoring server **106A** may include any type and form performance monitoring service **198**. The performance monitoring service **198** may include monitoring, measurement and/or management software and/or hardware, including data collection, aggregation, analysis, management and reporting. In one embodiment, the performance monitoring service **198** includes one or more monitoring agents **197**. The monitoring agent **197** includes any software, hardware or combination thereof for performing monitoring, measurement and data collection activities on a device, such as a client **102**, server **106** or an appliance **200**, **205**. In some embodiments, the monitoring agent **197** includes any type and form of script, such as Visual Basic script, or Javascript. In one embodiment, the monitoring agent **197** executes transparently to any application and/or user of the device. In some embodiments, the monitoring agent **197** is installed and operated unobtrusively to the application or client. In yet another embodiment, the monitoring agent **197** is installed and operated without any instrumentation for the application or device.

In some embodiments, the monitoring agent **197** monitors, measures and collects data on a predetermined frequency. In other embodiments, the monitoring agent **197** monitors, measures and collects data based upon detection of any type and form of event. For example, the monitoring agent **197** may collect data upon detection of a request for a web page or receipt of an HTTP response. In another example, the monitoring agent **197** may collect data upon detection of any user input events, such as a mouse click. The monitoring agent **197** may report or provide any monitored, measured or collected data to the monitoring service **198**. In one embodiment, the monitoring agent **197** transmits information to the monitoring service **198** according to a schedule or a predetermined frequency. In another embodiment, the monitoring agent **197** transmits information to the monitoring service **198** upon detection of an event.

In some embodiments, the monitoring service **198** and/or monitoring agent **197** performs monitoring and performance measurement of any network resource or network infrastructure element, such as a client, server, server farm, appliance **200**, appliance **205**, or network connection. In one embodiment, the monitoring service **198** and/or monitoring agent **197** performs monitoring and performance measurement of any transport layer connection, such as a TCP or UDP connection. In another embodiment, the monitoring service **198** and/or monitoring agent **197** monitors and measures network

latency. In yet one embodiment, the monitoring service **198** and/or monitoring agent **197** monitors and measures bandwidth utilization.

In other embodiments, the monitoring service **198** and/or monitoring agent **197** monitors and measures end-user response times. In some embodiments, the monitoring service **198** performs monitoring and performance measurement of an application. In another embodiment, the monitoring service **198** and/or monitoring agent **197** performs monitoring and performance measurement of any session or connection to the application. In one embodiment, the monitoring service **198** and/or monitoring agent **197** monitors and measures performance of a browser. In another embodiment, the monitoring service **198** and/or monitoring agent **197** monitors and measures performance of HTTP based transactions. In some embodiments, the monitoring service **198** and/or monitoring agent **197** monitors and measures performance of a Voice over IP (VoIP) application or session. In other embodiments, the monitoring service **198** and/or monitoring agent **197** monitors and measures performance of a remote display protocol application, such as an ICA client or RDP client. In yet another embodiment, the monitoring service **198** and/or monitoring agent **197** monitors and measures performance of any type and form of streaming media. In still a further embodiment, the monitoring service **198** and/or monitoring agent **197** monitors and measures performance of a hosted application or a Software-As-A-Service (SaaS) delivery model.

In some embodiments, the monitoring service **198** and/or monitoring agent **197** performs monitoring and performance measurement of one or more transactions, requests or responses related to application. In other embodiments, the monitoring service **198** and/or monitoring agent **197** monitors and measures any portion of an application layer stack, such as any .NET or J2EE calls. In one embodiment, the monitoring service **198** and/or monitoring agent **197** monitors and measures database or SQL transactions. In yet another embodiment, the monitoring service **198** and/or monitoring agent **197** monitors and measures any method, function or application programming interface (API) call.

In one embodiment, the monitoring service **198** and/or monitoring agent **197** performs monitoring and performance measurement of a delivery of application and/or data from a server to a client via one or more appliances, such as appliance **200** and/or appliance **205**. In some embodiments, the monitoring service **198** and/or monitoring agent **197** monitors and measures performance of delivery of a virtualized application. In other embodiments, the monitoring service **198** and/or monitoring agent **197** monitors and measures performance of delivery of a streaming application. In another embodiment, the monitoring service **198** and/or monitoring agent **197** monitors and measures performance of delivery of a desktop application to a client and/or the execution of the desktop application on the client. In another embodiment, the monitoring service **198** and/or monitoring agent **197** monitors and measures performance of a client/server application.

In one embodiment, the monitoring service **198** and/or monitoring agent **197** is designed and constructed to provide application performance management for the application delivery system **190**. For example, the monitoring service **198** and/or monitoring agent **197** may monitor, measure and manage the performance of the delivery of applications via the Citrix Presentation Server. In this example, the monitoring service **198** and/or monitoring agent **197** monitors individual ICA sessions. The monitoring service **198** and/or monitoring agent **197** may measure the total and per session system

resource usage, as well as application and networking performance. The monitoring service **198** and/or monitoring agent **197** may identify the active servers for a given user and/or user session. In some embodiments, the monitoring service **198** and/or monitoring agent **197** monitors back-end connections between the application delivery system **190** and an application and/or database server. The monitoring service **198** and/or monitoring agent **197** may measure network latency, delay and volume per user-session or ICA session.

In some embodiments, the monitoring service **198** and/or monitoring agent **197** measures and monitors memory usage for the application delivery system **190**, such as total memory usage, per user session and/or per process. In other embodiments, the monitoring service **198** and/or monitoring agent **197** measures and monitors CPU usage the application delivery system **190**, such as total CPU usage, per user session and/or per process. In another embodiment, the monitoring service **198** and/or monitoring agent **197** measures and monitors the time required to log-in to an application, a server, or the application delivery system, such as Citrix Presentation Server. In one embodiment, the monitoring service **198** and/or monitoring agent **197** measures and monitors the duration a user is logged into an application, a server, or the application delivery system **190**. In some embodiments, the monitoring service **198** and/or monitoring agent **197** measures and monitors active and inactive session counts for an application, server or application delivery system session. In yet another embodiment, the monitoring service **198** and/or monitoring agent **197** measures and monitors user session latency.

In yet further embodiments, the monitoring service **198** and/or monitoring agent **197** measures and monitors measures and monitors any type and form of server metrics. In one embodiment, the monitoring service **198** and/or monitoring agent **197** measures and monitors metrics related to system memory, CPU usage, and disk storage. In another embodiment, the monitoring service **198** and/or monitoring agent **197** measures and monitors metrics related to page faults, such as page faults per second. In other embodiments, the monitoring service **198** and/or monitoring agent **197** measures and monitors round-trip time metrics. In yet another embodiment, the monitoring service **198** and/or monitoring agent **197** measures and monitors metrics related to application crashes, errors and/or hangs.

In some embodiments, the monitoring service **198** and/or monitoring agent **198** includes any of the product embodiments referred to as EdgeSight manufactured by Citrix Systems, Inc. of Ft. Lauderdale, Fla. In another embodiment, the performance monitoring service **198** and/or monitoring agent **198** includes any portion of the product embodiments referred to as the TrueView product suite manufactured by the Symphoniq Corporation of Palo Alto, Calif. In one embodiment, the performance monitoring service **198** and/or monitoring agent **198** includes any portion of the product embodiments referred to as the TeaLeaf CX product suite manufactured by the TeaLeaf Technology Inc. of San Francisco, Calif. In other embodiments, the performance monitoring service **198** and/or monitoring agent **198** includes any portion of the business service management products, such as the BMC Performance Manager and Patrol products, manufactured by BMC Software, Inc. of Houston, Tex.

The client **102**, server **106**, and appliance **200** may be deployed as and/or executed on any type and form of computing device, such as a computer, network device or appliance capable of communicating on any type and form of network and performing the operations described herein. FIGS. 1E and 1F depict block diagrams of a computing device **100** useful for practicing an embodiment of the client **102**,

server **106** or appliance **200**. As shown in FIGS. **1E** and **1F**, each computing device **100** includes a central processing unit **101**, and a main memory unit **122**. As shown in FIG. **1E**, a computing device **100** may include a visual display device **124**, a keyboard **126** and/or a pointing device **127**, such as a mouse. Each computing device **100** may also include additional optional elements, such as one or more input/output devices **130a-130b** (generally referred to using reference numeral **130**), and a cache memory **140** in communication with the central processing unit **101**.

The central processing unit **101** is any logic circuitry that responds to and processes instructions fetched from the main memory unit **122**. In many embodiments, the central processing unit is provided by a microprocessor unit, such as: those manufactured by Intel Corporation of Mountain View, Calif.; those manufactured by Motorola Corporation of Schaumburg, Ill.; those manufactured by Transmeta Corporation of Santa Clara, Calif.; the RS/6000 processor, those manufactured by International Business Machines of White Plains, N.Y.; or those manufactured by Advanced Micro Devices of Sunnyvale, Calif. The computing device **100** may be based on any of these processors, or any other processor capable of operating as described herein.

Main memory unit **122** may be one or more memory chips capable of storing data and allowing any storage location to be directly accessed by the microprocessor **101**, such as Static random access memory (SRAM), Burst SRAM or Synchronous SRAM (BSRAM), Dynamic random access memory (DRAM), Fast Page Mode DRAM (FPM DRAM), Enhanced DRAM (EDRAM), Extended Data Output RAM (EDO RAM), Extended Data Output DRAM (EDO DRAM), Burst Extended Data Output DRAM (BEDO DRAM), Enhanced DRAM (EDRAM), synchronous DRAM (SDRAM), JEDEC SRAM, PC100 SDRAM, Double Data Rate SDRAM (DDR SDRAM), Enhanced SDRAM (ESDRAM), SyncLink DRAM (SLDRAM), Direct Rambus DRAM (DRDRAM), or Ferroelectric RAM (FRAM). The main memory **122** may be based on any of the above described memory chips, or any other available memory chips capable of operating as described herein. In the embodiment shown in FIG. **1E**, the processor **101** communicates with main memory **122** via a system bus **150** (described in more detail below). FIG. **1F** depicts an embodiment of a computing device **100** in which the processor communicates directly with main memory **122** via a memory port **103**. For example, in FIG. **1F** the main memory **122** may be DRDRAM.

FIG. **1F** depicts an embodiment in which the main processor **101** communicates directly with cache memory **140** via a secondary bus, sometimes referred to as a backside bus. In other embodiments, the main processor **101** communicates with cache memory **140** using the system bus **150**. Cache memory **140** typically has a faster response time than main memory **122** and is typically provided by SRAM, BSRAM, or EDRAM. In the embodiment shown in FIG. **1F**, the processor **101** communicates with various I/O devices **130** via a local system bus **150**. Various busses may be used to connect the central processing unit **101** to any of the I/O devices **130**, including a VESA VL bus, an ISA bus, an EISA bus, a MicroChannel Architecture (MCA) bus, a PCI bus, a PCI-X bus, a PCI-Express bus, or a NuBus. For embodiments in which the I/O device is a video display **124**, the processor **101** may use an Advanced Graphics Port (AGP) to communicate with the display **124**. FIG. **1F** depicts an embodiment of a computer **100** in which the main processor **101** communicates directly with I/O device **130b** via HyperTransport, Rapid I/O, or InfiniBand. FIG. **1F** also depicts an embodiment in which local busses and direct communication are mixed:

the processor **101** communicates with I/O device **130b** using a local interconnect bus while communicating with I/O device **130a** directly.

The computing device **100** may support any suitable installation device **116**, such as a floppy disk drive for receiving floppy disks such as 3.5-inch, 5.25-inch disks or ZIP disks, a CD-ROM drive, a CD-R/RW drive, a DVD-ROM drive, tape drives of various formats, USB device, hard-drive or any other device suitable for installing software and programs such as any client agent **120**, or portion thereof. The computing device **100** may further comprise a storage device **128**, such as one or more hard disk drives or redundant arrays of independent disks, for storing an operating system and other related software, and for storing application software programs such as any program related to the client agent **120**. Optionally, any of the installation devices **116** could also be used as the storage device **128**. Additionally, the operating system and the software can be run from a bootable medium, for example, a bootable CD, such as KNOPPIX®, a bootable CD for GNU/Linux that is available as a GNU/Linux distribution from knoppix.net.

Furthermore, the computing device **100** may include a network interface **118** to interface to a Local Area Network (LAN), Wide Area Network (WAN) or the Internet through a variety of connections including, but not limited to, standard telephone lines, LAN or WAN links (e.g., 802.11, T1, T3, 56 kb, X.25), broadband connections (e.g., ISDN, Frame Relay, ATM), wireless connections, or some combination of any or all of the above. The network interface **118** may comprise a built-in network adapter, network interface card, PCMCIA network card, card bus network adapter, wireless network adapter, USB network adapter, modem or any other device suitable for interfacing the computing device **100** to any type of network capable of communication and performing the operations described herein. A wide variety of I/O devices **130a-130n** may be present in the computing device **100**. Input devices include keyboards, mice, trackpads, trackballs, microphones, and drawing tablets. Output devices include video displays, speakers, inkjet printers, laser printers, and dye-sublimation printers. The I/O devices **130** may be controlled by an I/O controller **123** as shown in FIG. **1E**. The I/O controller may control one or more I/O devices such as a keyboard **126** and a pointing device **127**, e.g., a mouse or optical pen. Furthermore, an I/O device may also provide storage **128** and/or an installation medium **116** for the computing device **100**. In still other embodiments, the computing device **100** may provide USB connections to receive handheld USB storage devices such as the USB Flash Drive line of devices manufactured by Twintech Industry, Inc. of Los Alamitos, Calif.

In some embodiments, the computing device **100** may comprise or be connected to multiple display devices **124a-124n**, which each may be of the same or different type and/or form. As such, any of the I/O devices **130a-130n** and/or the I/O controller **123** may comprise any type and/or form of suitable hardware, software, or combination of hardware and software to support, enable or provide for the connection and use of multiple display devices **124a-124n** by the computing device **100**. For example, the computing device **100** may include any type and/or form of video adapter, video card, driver, and/or library to interface, communicate, connect or otherwise use the display devices **124a-124n**. In one embodiment, a video adapter may comprise multiple connectors to interface to multiple display devices **124a-124n**. In other embodiments, the computing device **100** may include multiple video adapters, with each video adapter connected to one or more of the display devices **124a-124n**. In some embodi-

ments, any portion of the operating system of the computing device **100** may be configured for using multiple displays **124a-124n**. In other embodiments, one or more of the display devices **124a-124n** may be provided by one or more other computing devices, such as computing devices **100a** and **100b** connected to the computing device **100**, for example, via a network. These embodiments may include any type of software designed and constructed to use another computer's display device as a second display device **124a** for the computing device **100**. One ordinarily skilled in the art will recognize and appreciate the various ways and embodiments that a computing device **100** may be configured to have multiple display devices **124a-124n**.

In further embodiments, an I/O device **130** may be a bridge **170** between the system bus **150** and an external communication bus, such as a USB bus, an Apple Desktop Bus, an RS-232 serial connection, a SCSI bus, a FireWire bus, a FireWire 800 bus, an Ethernet bus, an AppleTalk bus, a Gigabit Ethernet bus, an Asynchronous Transfer Mode bus, a HIPPI bus, a Super HIPPI bus, a SerialPlus bus, a SCI/LAMP bus, a FibreChannel bus, or a Serial Attached small computer system interface bus.

A computing device **100** of the sort depicted in FIGS. **1E** and **1F** typically operate under the control of operating systems, which control scheduling of tasks and access to system resources. The computing device **100** can be running any operating system such as any of the versions of the Microsoft® Windows operating systems, the different releases of the Unix and Linux operating systems, any version of the Mac OS® for Macintosh computers, any embedded operating system, any real-time operating system, any open source operating system, any proprietary operating system, any operating systems for mobile computing devices, or any other operating system capable of running on the computing device and performing the operations described herein. Typical operating systems include: WINDOWS 3.x, WINDOWS 95, WINDOWS 98, WINDOWS 2000, WINDOWS NT 3.51, WINDOWS NT 4.0, WINDOWS CE, WINDOWS XP, WINDOWS 7, WINDOWS 8, and WINDOWS SERVER 2012, all of which are manufactured by Microsoft Corporation of Redmond, Wash.; MacOS, manufactured by Apple Computer of Cupertino, Calif.; OS/2, manufactured by International Business Machines of Armonk, N.Y.; and Linux, a freely-available operating system distributed by Caldera Corp. of Salt Lake City, Utah, or any type and/or form of a Unix operating system, among others.

In other embodiments, the computing device **100** may have different processors, operating systems, and input devices consistent with the device. For example, in one embodiment the computer **100** is a Treo 180, 270, 1060, 600 or 650 smart phone manufactured by Palm, Inc. In this embodiment, the Treo smart phone is operated under the control of the PalmOS operating system and includes a stylus input device as well as a five-way navigator device. Moreover, the computing device **100** can be any workstation, desktop computer, laptop or notebook computer, server, handheld computer, mobile telephone, any other computer, or other form of computing or telecommunications device that is capable of communication and that has sufficient processor power and memory capacity to perform the operations described herein.

As shown in FIG. **1G**, the computing device **100** may comprise multiple processors and may provide functionality for simultaneous execution of instructions or for simultaneous execution of one instruction on more than one piece of data. In some embodiments, the computing device **100** may comprise a parallel processor with one or more cores. In one of these embodiments, the computing device **100** is a shared

memory parallel device, with multiple processors and/or multiple processor cores, accessing all available memory as a single global address space. In another of these embodiments, the computing device **100** is a distributed memory parallel device with multiple processors each accessing local memory only. In still another of these embodiments, the computing device **100** has both some memory which is shared and some memory which can only be accessed by particular processors or subsets of processors. In still even another of these embodiments, the computing device **100**, such as a multi-core microprocessor, combines two or more independent processors into a single package, often a single integrated circuit (IC). In yet another of these embodiments, the computing device **100** includes a chip having a CELL BROADBAND ENGINE architecture and including a Power processor element and a plurality of synergistic processing elements, the Power processor element and the plurality of synergistic processing elements linked together by an internal high speed bus, which may be referred to as an element interconnect bus.

In some embodiments, the processors provide functionality for execution of a single instruction simultaneously on multiple pieces of data (SIMD). In other embodiments, the processors provide functionality for execution of multiple instructions simultaneously on multiple pieces of data (MIMD). In still other embodiments, the processor may use any combination of SIMD and MIMD cores in a single device.

In some embodiments, the computing device **100** may comprise a graphics processing unit. In one of these embodiments, depicted in FIG. **1H**, the computing device **100** includes at least one central processing unit **101** and at least one graphics processing unit. In another of these embodiments, the computing device **100** includes at least one parallel processing unit and at least one graphics processing unit. In still another of these embodiments, the computing device **100** includes a plurality of processing units of any type, one of the plurality of processing units comprising a graphics processing unit.

In some embodiments, a first computing device **100**, e.g., a server **106a**, executes an application on behalf of a user of a client computing device **100**, e.g., a client **102a**. In other embodiments, a computing device **100**, e.g., a server **106a**, executes a virtual machine, which provides an execution session within which applications execute on behalf of a user or a client computing devices **100**, e.g., a client **102a**. In one of these embodiments, the execution session is a hosted desktop session. In another of these embodiments, the computing device **100** executes a terminal services session. The terminal services session may provide a hosted desktop environment. In still another of these embodiments, the execution session provides access to a computing environment, which may comprise one or more of: an application, a plurality of applications, a desktop application, and a desktop session in which one or more applications may execute.

B. Appliance Architecture

FIG. **2A** illustrates an example embodiment of the appliance **200**. The architecture of the appliance **200** in FIG. **2A** is provided by way of illustration only and is not intended to be limiting. As shown in FIG. **2**, appliance **200** comprises a hardware layer **206** and a software layer divided into a user space **202** and a kernel space **204**.

Hardware layer **206** provides the hardware elements upon which programs and services within kernel space **204** and user space **202** are executed. Hardware layer **206** also provides the structures and elements which allow programs and services within kernel space **204** and user space **202** to communicate data both internally and externally with respect to

appliance 200. As shown in FIG. 2, the hardware layer 206 includes a processing unit 262 for executing software programs and services, a memory 264 for storing software and data, network ports 266 for transmitting and receiving data over a network, and an encryption processor 260 for performing functions related to Secure Sockets Layer processing of data transmitted and received over the network. In some embodiments, the central processing unit 262 may perform the functions of the encryption processor 260 in a single processor. Additionally, the hardware layer 206 may comprise multiple processors for each of the processing unit 262 and the encryption processor 260. The processor 262 may include any of the processors 101 described above in connection with FIGS. 1E and 1F. For example, in one embodiment, the appliance 200 comprises a first processor 262 and a second processor 262'. In other embodiments, the processor 262 or 262' comprises a multi-core processor.

Although the hardware layer 206 of appliance 200 is generally illustrated with an encryption processor 260, processor 260 may be a processor for performing functions related to any encryption protocol, such as the Secure Socket Layer (SSL) or Transport Layer Security (TLS) protocol. In some embodiments, the processor 260 may be a general purpose processor (GPP), and in further embodiments, may have executable instructions for performing processing of any security related protocol.

Although the hardware layer 206 of appliance 200 is illustrated with certain elements in FIG. 2, the hardware portions or components of appliance 200 may comprise any type and form of elements, hardware or software, of a computing device, such as the computing device 100 illustrated and discussed herein in conjunction with FIGS. 1E and 1F. In some embodiments, the appliance 200 may comprise a server, gateway, router, switch, bridge or other type of computing or network device, and have any hardware and/or software elements associated therewith.

The operating system of appliance 200 allocates, manages, or otherwise segregates the available system memory into kernel space 204 and user space 204. In example software architecture 200, the operating system may be any type and/or form of Unix operating system although the present solution is not so limited. As such, the appliance 200 can be running any operating system such as any of the versions of the Microsoft® Windows operating systems, the different releases of the Unix and Linux operating systems, any version of the Mac OS® for Macintosh computers, any embedded operating system, any network operating system, any real-time operating system, any open source operating system, any proprietary operating system, any operating systems for mobile computing devices or network devices, or any other operating system capable of running on the appliance 200 and performing the operations described herein.

The kernel space 204 is reserved for running the kernel 230, including any device drivers, kernel extensions or other kernel related software. As known to those skilled in the art, the kernel 230 is the core of the operating system, and provides access, control, and management of resources and hardware-related elements of the application 104. In accordance with an embodiment of the appliance 200, the kernel space 204 also includes a number of network services or processes working in conjunction with a cache manager 232, sometimes also referred to as the integrated cache, the benefits of which are described in detail further herein. Additionally, the embodiment of the kernel 230 will depend on the embodiment of the operating system installed, configured, or otherwise used by the device 200.

In one embodiment, the device 200 comprises one network stack 267, such as a TCP/IP based stack, for communicating with the client 102 and/or the server 106. In one embodiment, the network stack 267 is used to communicate with a first network, such as network 104, and a second network 104'. In some embodiments, the device 200 terminates a first transport layer connection, such as a TCP connection of a client 102, and establishes a second transport layer connection to a server 106 for use by the client 102, e.g., the second transport layer connection is terminated at the appliance 200 and the server 106. The first and second transport layer connections may be established via a single network stack 267. In other embodiments, the device 200 may comprise multiple network stacks, for example a first stack 267 and a second stack 267, and the first transport layer connection may be established or terminated at one network stack 267, and the second transport layer connection on the second network stack 267. For example, one network stack may be for receiving and transmitting network packet on a first network, and another network stack for receiving and transmitting network packets on a second network. In one embodiment, the network stack 267 comprises a buffer 243 for queuing one or more network packets for transmission by the appliance 200.

As shown in FIG. 2A, the kernel space 204 includes the cache manager 232, a high-speed layer 2-7 integrated packet engine 240, an encryption engine 234, a policy engine 236 and multi-protocol compression logic 238. Running these components or processes 232, 240, 234, 236 and 238 in kernel space 204 or kernel mode instead of the user space 202 improves the performance of each of these components, alone and in combination. Kernel operation means that these components or processes 232, 240, 234, 236 and 238 run in the core address space of the operating system of the device 200. For example, running the encryption engine 234 in kernel mode improves encryption performance by moving encryption and decryption operations to the kernel, thereby reducing the number of transitions between the memory space or a kernel thread in kernel mode and the memory space or a thread in user mode. For example, data obtained in kernel mode may not need to be passed or copied to a process or thread running in user mode, such as from a kernel level data structure to a user level data structure. In another aspect, the number of context switches between kernel mode and user mode are also reduced. Additionally, synchronization of and communications between any of the components or processes 232, 240, 235, 236 and 238 can be performed more efficiently in the kernel space 204.

In some embodiments, any portion of the components 232, 240, 234, 236 and 238 may run or operate in the kernel space 204, while other portions of these components 232, 240, 234, 236 and 238 may run or operate in user space 202. In one embodiment, the appliance 200 uses a kernel-level data structure providing access to any portion of one or more network packets, for example, a network packet comprising a request from a client 102 or a response from a server 106. In some embodiments, the kernel-level data structure may be obtained by the packet engine 240 via a transport layer driver interface or filter to the network stack 267. The kernel-level data structure may comprise any interface and/or data accessible via the kernel space 204 related to the network stack 267, network traffic or packets received or transmitted by the network stack 267. In other embodiments, the kernel-level data structure may be used by any of the components or processes 232, 240, 234, 236 and 238 to perform the desired operation of the component or process. In one embodiment, a component 232, 240, 234, 236 and 238 is running in kernel mode 204 when using the kernel-level data structure, while in another

embodiment, the component **232**, **240**, **234**, **236** and **238** is running in user mode when using the kernel-level data structure. In some embodiments, the kernel-level data structure may be copied or passed to a second kernel-level data structure, or any desired user-level data structure.

The cache manager **232** may comprise software, hardware or any combination of software and hardware to provide cache access, control and management of any type and form of content, such as objects or dynamically generated objects served by the originating servers **106**. The data, objects or content processed and stored by the cache manager **232** may comprise data in any format, such as a markup language, or communicated via any protocol. In some embodiments, the cache manager **232** duplicates original data stored elsewhere or data previously computed, generated or transmitted, in which the original data may require longer access time to fetch, compute or otherwise obtain relative to reading a cache memory element. Once the data is stored in the cache memory element, future use can be made by accessing the cached copy rather than refetching or recomputing the original data, thereby reducing the access time. In some embodiments, the cache memory element may comprise a data object in memory **264** of device **200**. In other embodiments, the cache memory element may comprise memory having a faster access time than memory **264**. In another embodiment, the cache memory element may comprise any type and form of storage element of the device **200**, such as a portion of a hard disk. In some embodiments, the processing unit **262** may provide cache memory for use by the cache manager **232**. In yet further embodiments, the cache manager **232** may use any portion and combination of memory, storage, or the processing unit for caching data, objects, and other content.

Furthermore, the cache manager **232** includes any logic, functions, rules, or operations to perform any embodiments of the techniques of the appliance **200** described herein. For example, the cache manager **232** includes logic or functionality to invalidate objects based on the expiration of an invalidation time period or upon receipt of an invalidation command from a client **102** or server **106**. In some embodiments, the cache manager **232** may operate as a program, service, process or task executing in the kernel space **204**, and in other embodiments, in the user space **202**. In one embodiment, a first portion of the cache manager **232** executes in the user space **202** while a second portion executes in the kernel space **204**. In some embodiments, the cache manager **232** can comprise any type of general purpose processor (GPP), or any other type of integrated circuit, such as a Field Programmable Gate Array (FPGA), Programmable Logic Device (PLD), or Application Specific Integrated Circuit (ASIC).

The policy engine **236** may include, for example, an intelligent statistical engine or other programmable application (s). In one embodiment, the policy engine **236** provides a configuration mechanism to allow a user to identify, specify, define or configure a caching policy. Policy engine **236**, in some embodiments, also has access to memory to support data structures such as lookup tables or hash tables to enable user-selected caching policy decisions. In other embodiments, the policy engine **236** may comprise any logic, rules, functions or operations to determine and provide access, control and management of objects, data or content being cached by the appliance **200** in addition to access, control and management of security, network traffic, network access, compression or any other function or operation performed by the appliance **200**. Further examples of specific caching policies are further described herein.

The encryption engine **234** comprises any logic, business rules, functions or operations for handling the processing of

any security related protocol, such as SSL or TLS, or any function related thereto. For example, the encryption engine **234** encrypts and decrypts network packets, or any portion thereof, communicated via the appliance **200**. The encryption engine **234** may also setup or establish SSL or TLS connections on behalf of the client **102a-102n**, server **106a-106n**, or appliance **200**. As such, the encryption engine **234** provides offloading and acceleration of SSL processing. In one embodiment, the encryption engine **234** uses a tunneling protocol to provide a virtual private network between a client **102a-102n** and a server **106a-106n**. In some embodiments, the encryption engine **234** is in communication with the Encryption processor **260**. In other embodiments, the encryption engine **234** comprises executable instructions running on the Encryption processor **260**.

The multi-protocol compression engine **238** comprises any logic, business rules, function or operations for compressing one or more protocols of a network packet, such as any of the protocols used by the network stack **267** of the device **200**. In one embodiment, multi-protocol compression engine **238** compresses bi-directionally between clients **102a-102n** and servers **106a-106n** any TCP/IP based protocol, including Messaging Application Programming Interface (MAPI) (email), File Transfer Protocol (FTP), HyperText Transfer Protocol (HTTP), Common Internet File System (CIFS) protocol (file transfer), Independent Computing Architecture (ICA) protocol, Remote Desktop Protocol (RDP), Wireless Application Protocol (WAP), Mobile IP protocol, and Voice Over IP (VoIP) protocol. In other embodiments, multi-protocol compression engine **238** provides compression of Hypertext Markup Language (HTML) based protocols and in some embodiments, provides compression of any markup languages, such as the Extensible Markup Language (XML). In one embodiment, the multi-protocol compression engine **238** provides compression of any high-performance protocol, such as any protocol designed for appliance to appliance communications. In another embodiment, the multi-protocol compression engine **238** compresses any payload of or any communication using a modified transport control protocol, such as Transaction TCP (T/TCP), TCP with selection acknowledgements (TCP-SACK), TCP with large windows (TCP-LW), a congestion prediction protocol such as the TCP-Vegas protocol, and a TCP spoofing protocol.

As such, the multi-protocol compression engine **238** accelerates performance for users accessing applications via desktop clients, e.g., Microsoft Outlook and non-Web thin clients, such as any client launched by popular enterprise applications like Oracle, SAP and Siebel, and even mobile clients, such as the Pocket PC or Android. In some embodiments, the multi-protocol compression engine **238** by executing in the kernel mode **204** and integrating with packet processing engine **240** accessing the network stack **267** is able to compress any of the protocols carried by the TCP/IP protocol, such as any application layer protocol.

High speed layer 2-7 integrated packet engine **240**, also generally referred to as a packet processing engine or packet engine, is responsible for managing the kernel-level processing of packets received and transmitted by appliance **200** via network ports **266**. The high speed layer 2-7 integrated packet engine **240** may comprise a buffer for queuing one or more network packets during processing, such as for receipt of a network packet or transmission of a network packet. Additionally, the high speed layer 2-7 integrated packet engine **240** is in communication with one or more network stacks **267** to send and receive network packets via network ports **266**. The high speed layer 2-7 integrated packet engine **240** works in conjunction with encryption engine **234**, cache manager **232**,

policy engine **236** and multi-protocol compression logic **238**. In particular, encryption engine **234** is configured to perform SSL processing of packets, policy engine **236** is configured to perform functions related to traffic management such as request-level content switching and request-level cache redirection, and multi-protocol compression logic **238** is configured to perform functions related to compression and decompression of data.

The high speed layer 2-7 integrated packet engine **240** includes a packet processing timer **242**. In one embodiment, the packet processing timer **242** provides one or more time intervals to trigger the processing of incoming, i.e., received, or outgoing, i.e., transmitted, network packets. In some embodiments, the high speed layer 2-7 integrated packet engine **240** processes network packets responsive to the timer **242**. The packet processing timer **242** provides any type and form of signal to the packet engine **240** to notify, trigger, or communicate a time related event, interval or occurrence. In many embodiments, the packet processing timer **242** operates in the order of milliseconds, such as for example 100 ms, 50 ms or 25 ms. For example, in some embodiments, the packet processing timer **242** provides time intervals or otherwise causes a network packet to be processed by the high speed layer 2-7 integrated packet engine **240** at a 10 ms time interval, while in other embodiments, at a 5 ms time interval, and still yet in further embodiments, as short as a 3, 2, or 1 ms time interval. The high speed layer 2-7 integrated packet engine **240** may be interfaced, integrated or in communication with the encryption engine **234**, cache manager **232**, policy engine **236** and multi-protocol compression engine **238** during operation. As such, any of the logic, functions, or operations of the encryption engine **234**, cache manager **232**, policy engine **236** and multi-protocol compression logic **238** may be performed responsive to the packet processing timer **242** and/or the packet engine **240**. Therefore, any of the logic, functions, or operations of the encryption engine **234**, cache manager **232**, policy engine **236** and multi-protocol compression logic **238** may be performed at the granularity of time intervals provided via the packet processing timer **242**, for example, at a time interval of less than or equal to 10 ms. For example, in one embodiment, the cache manager **232** may perform invalidation of any cached objects responsive to the high speed layer 2-7 integrated packet engine **240** and/or the packet processing timer **242**. In another embodiment, the expiry or invalidation time of a cached object can be set to the same order of granularity as the time interval of the packet processing timer **242**, such as at every 10 ms.

In contrast to kernel space **204**, user space **202** is the memory area or portion of the operating system used by user mode applications or programs otherwise running in user mode. A user mode application may not access kernel space **204** directly and uses service calls in order to access kernel services. As shown in FIG. 2A, user space **202** of appliance **200** includes a graphical user interface (GUI) **210**, a command line interface (CLI) **212**, shell services **214**, health monitoring program **216**, and daemon services **218**. GUI **210** and CLI **212** provide a means by which a system administrator or other user can interact with and control the operation of appliance **200**, such as via the operating system of the appliance **200**. The GUI **210** or CLI **212** can comprise code running in user space **202** or kernel space **204**. The GUI **210** may be any type and form of graphical user interface and may be presented via text, graphical or otherwise, by any type of program or application, such as a browser. The CLI **212** may be any type and form of command line or text-based interface, such as a command line provided by the operating system. For example, the CLI **212** may comprise a shell, which is a tool to

enable users to interact with the operating system. In some embodiments, the CLI **212** may be provided via a bash, csh, tcsh, or ksh type shell. The shell services **214** comprises the programs, services, tasks, processes or executable instructions to support interaction with the appliance **200** or operating system by a user via the GUI **210** and/or CLI **212**.

Health monitoring program **216** is used to monitor, check, report and ensure that network systems are functioning properly and that users are receiving requested content over a network. Health monitoring program **216** comprises one or more programs, services, tasks, processes or executable instructions to provide logic, rules, functions or operations for monitoring any activity of the appliance **200**. In some embodiments, the health monitoring program **216** intercepts and inspects any network traffic passed via the appliance **200**. In other embodiments, the health monitoring program **216** interfaces by any suitable means and/or mechanisms with one or more of the following: the encryption engine **234**, cache manager **232**, policy engine **236**, multi-protocol compression logic **238**, packet engine **240**, daemon services **218**, and shell services **214**. As such, the health monitoring program **216** may call any application programming interface (API) to determine a state, status, or health of any portion of the appliance **200**. For example, the health monitoring program **216** may ping or send a status inquiry on a periodic basis to check if a program, process, service or task is active and currently running. In another example, the health monitoring program **216** may check any status, error or history logs provided by any program, process, service or task to determine any condition, status or error with any portion of the appliance **200**.

Daemon services **218** are programs that run continuously or in the background and handle periodic service requests received by appliance **200**. In some embodiments, a daemon service may forward the requests to other programs or processes, such as another daemon service **218** as appropriate. As known to those skilled in the art, a daemon service **218** may run unattended to perform continuous or periodic system wide functions, such as network control, or to perform any desired task. In some embodiments, one or more daemon services **218** run in the user space **202**; in some embodiments, one or more daemon services **218** run in the kernel space.

Referring now to FIG. 2B, another embodiment of the appliance **200** is depicted. In brief overview, the appliance **200** provides one or more of the following services, functionality or operations: SSL VPN connectivity **280**, switching/load balancing **284**, Domain Name Service resolution **286**, acceleration **288** and an application firewall **290** for communications between one or more clients **102** and one or more servers **106**. Each of the servers **106** may provide one or more network related services **270a-270n** (referred to as services **270**). For example, a server **106** may provide an http service **270**. The appliance **200** comprises one or more virtual servers or virtual internet protocol servers, referred to as a vServer, VIP server, or just VIP **275a-275n** (also referred herein as vServer **275**). The vServer **275** receives, intercepts or otherwise processes communications between a client **102** and a server **106** in accordance with the configuration and operations of the appliance **200**.

The vServer **275** may comprise software, hardware or any combination of software and hardware. The vServer **275** may comprise any type and form of program, service, task, process or executable instructions operating in user mode **202**, kernel mode **204** or any combination thereof in the appliance **200**. The vServer **275** includes any logic, functions, rules, or operations to perform any embodiments of the techniques described herein, such as SSL VPN **280**, switching/load bal-

ancing **284**, Domain Name Service resolution **286**, acceleration **288** and an application firewall **290**. In some embodiments, the vServer **275** establishes a connection to a service **270** of a server **106**. The service **270** may comprise any program, application, process, task or set of executable instructions capable of connecting to and communicating with the appliance **200**, client **102** or vServer **275**. For example, the service **270** may comprise a web server, http server, ftp, email or database server. In some embodiments, the service **270** is a daemon process or network driver for listening, receiving and/or sending communications for an application, such as email, database or an enterprise application. In some embodiments, the service **270** may communicate on a specific IP address, or IP address and port.

In some embodiments, the vServer **275** applies one or more policies of the policy engine **236** to network communications between the client **102** and server **106**. In one embodiment, the policies are associated with a vServer **275**. In another embodiment, the policies are based on a user, or a group of users. In yet another embodiment, a policy is global and applies to one or more vServers **275a-275n**, and any user or group of users communicating via the appliance **200**. In some embodiments, the policies of the policy engine **236** have conditions upon which the policy is applied based on any content of the communication, such as internet protocol address, port, protocol type, header or fields in a packet, or the context of the communication, such as user, group of the user, vServer **275**, transport layer connection, and/or identification or attributes of the client **102** or server **106**.

In other embodiments, the appliance **200** communicates or interfaces with the policy engine **236** to determine authentication and/or authorization of a remote user or a remote client **102** to access the computing environment **15**, application, and/or data file from a server **106**. In another embodiment, the appliance **200** communicates or interfaces with the policy engine **236** to determine authentication and/or authorization of a remote user or a remote client **102** to have the application delivery system **190** deliver one or more of the computing environment **15**, application, and/or data file. In yet another embodiment, the appliance **200** establishes a VPN or SSL VPN connection based on the policy engine's **236** authentication and/or authorization of a remote user or a remote client **102**. In one embodiment, the appliance **200** controls the flow of network traffic and communication sessions based on policies of the policy engine **236**. For example, the appliance **200** may control the access to a computing environment **15**, application or data file based on the policy engine **236**.

In some embodiments, the vServer **275** establishes a transport layer connection, such as a TCP or UDP connection with a client **102** via the client agent **120**. In one embodiment, the vServer **275** listens for and receives communications from the client **102**. In other embodiments, the vServer **275** establishes a transport layer connection, such as a TCP or UDP connection with a client server **106**. In one embodiment, the vServer **275** establishes the transport layer connection to an internet protocol address and port of a server **270** running on the server **106**. In another embodiment, the vServer **275** associates a first transport layer connection to a client **102** with a second transport layer connection to the server **106**. In some embodiments, a vServer **275** establishes a pool of transport layer connections to a server **106** and multiplexes client requests via the pooled transport layer connections.

In some embodiments, the appliance **200** provides a SSL VPN connection **280** between a client **102** and a server **106**. For example, a client **102** on a first network **102** requests to establish a connection to a server **106** on a second network **104'**. In some embodiments, the second network **104'** is not

routable from the first network **104**. In other embodiments, the client **102** is on a public network **104** and the server **106** is on a private network **104'**, such as a corporate network. In one embodiment, the client agent **120** intercepts communications of the client **102** on the first network **104**, encrypts the communications, and transmits the communications via a first transport layer connection to the appliance **200**. The appliance **200** associates the first transport layer connection on the first network **104** to a second transport layer connection to the server **106** on the second network **104**. The appliance **200** receives the intercepted communication from the client agent **102**, decrypts the communications, and transmits the communication to the server **106** on the second network **104** via the second transport layer connection. The second transport layer connection may be a pooled transport layer connection. As such, the appliance **200** provides an end-to-end secure transport layer connection for the client **102** between the two networks **104, 104'**.

In one embodiment, the appliance **200** hosts an intranet internet protocol or IntranetIP **282** address of the client **102** on the virtual private network **104**. The client **102** has a local network identifier, such as an internet protocol (IP) address and/or host name on the first network **104**. When connected to the second network **104'** via the appliance **200**, the appliance **200** establishes, assigns or otherwise provides an IntranetIP address **282**, which is a network identifier, such as IP address and/or host name, for the client **102** on the second network **104'**. The appliance **200** listens for and receives on the second or private network **104'** for any communications directed towards the client **102** using the client's established IntranetIP **282**. In one embodiment, the appliance **200** acts as or on behalf of the client **102** on the second private network **104**. For example, in another embodiment, a vServer **275** listens for and responds to communications to the IntranetIP **282** of the client **102**. In some embodiments, if a computing device **100** on the second network **104'** transmits a request, the appliance **200** processes the request as if it were the client **102**. For example, the appliance **200** may respond to a ping to the client's IntranetIP **282**. In another example, the appliance may establish a connection, such as a TCP or UDP connection, with computing device **100** on the second network **104** requesting a connection with the client's IntranetIP **282**.

In some embodiments, the appliance **200** provides one or more of the following acceleration techniques **288** to communications between the client **102** and server **106**: 1) compression; 2) decompression; 3) Transmission Control Protocol pooling; 4) Transmission Control Protocol multiplexing; 5) Transmission Control Protocol buffering; and 6) caching. In one embodiment, the appliance **200** relieves servers **106** of much of the processing load caused by repeatedly opening and closing transport layers connections to clients **102** by opening one or more transport layer connections with each server **106** and maintaining these connections to allow repeated data accesses by clients via the Internet. This technique is referred to herein as "connection pooling".

In some embodiments, in order to seamlessly splice communications from a client **102** to a server **106** via a pooled transport layer connection, the appliance **200** translates or multiplexes communications by modifying sequence number and acknowledgment numbers at the transport layer protocol level. This is referred to as "connection multiplexing". In some embodiments, no application layer protocol interaction is required. For example, in the case of an in-bound packet (that is, a packet received from a client **102**), the source network address of the packet is changed to that of an output port of appliance **200**, and the destination network address is changed to that of the intended server. In the case of an

25

outbound packet (that is, one received from a server **106**), the source network address is changed from that of the server **106** to that of an output port of appliance **200** and the destination address is changed from that of appliance **200** to that of the receiving client **102**. The sequence numbers and acknowledgment numbers of the packet are also translated to sequence numbers and acknowledgment numbers expected by the client **102** on the appliance's **200** transport layer connection to the client **102**. In some embodiments, the packet checksum of the transport layer protocol is recalculated to account for these translations.

In another embodiment, the appliance **200** provides switching or load-balancing functionality **284** for communications between the client **102** and server **106**. In some embodiments, the appliance **200** distributes traffic and directs client requests to a server **106** based on layer 4 or application-layer request data. In one embodiment, although the network layer or layer 2 of the network packet identifies a destination server **106**, the appliance **200** determines the server **106** to distribute the network packet by application information and data carried as payload of the transport layer packet. In one embodiment, the health monitoring programs **216** of the appliance **200** monitor the health of servers to determine the server **106** for which to distribute a client's request. In some embodiments, if the appliance **200** detects a server **106** is not available or has a load over a predetermined threshold, the appliance **200** can direct or distribute client requests to another server **106**.

In some embodiments, the appliance **200** acts as a Domain Name Service (DNS) resolver or otherwise provides resolution of a DNS request from clients **102**. In some embodiments, the appliance intercepts a DNS request transmitted by the client **102**. In one embodiment, the appliance **200** responds to a client's DNS request with an IP address of or hosted by the appliance **200**. In this embodiment, the client **102** transmits network communication for the domain name to the appliance **200**. In another embodiment, the appliance **200** responds to a client's DNS request with an IP address of or hosted by a second appliance **200'**. In some embodiments, the appliance **200** responds to a client's DNS request with an IP address of a server **106** determined by the appliance **200**.

In yet another embodiment, the appliance **200** provides application firewall functionality **290** for communications between the client **102** and server **106**. In one embodiment, the policy engine **236** provides rules for detecting and blocking illegitimate requests. In some embodiments, the application firewall **290** protects against denial of service (DoS) attacks. In other embodiments, the appliance inspects the content of intercepted requests to identify and block application-based attacks. In some embodiments, the rules/policy engine **236** comprises one or more application firewall or security control policies for providing protections against various classes and types of web or Internet based vulnerabilities, such as one or more of the following: 1) buffer overflow, 2) CGI-BIN parameter manipulation, 3) form/hidden field manipulation, 4) forceful browsing, 5) cookie or session poisoning, 6) broken access control list (ACLs) or weak passwords, 7) cross-site scripting (XSS), 8) command injection, 9) SQL injection, 10) error triggering sensitive information leak, 11) insecure use of cryptography, 12) server misconfiguration, 13) back doors and debug options, 14) website defacement, 15) platform or operating systems vulnerabilities, and 16) zero-day exploits. In an embodiment, the application firewall **290** provides HTML form field protection in the form of inspecting or analyzing the network communication for one or more of the following: 1) required fields are returned, 2) no added field allowed, 3) read-only and hidden

26

field enforcement, 4) drop-down list and radio button field conformance, and 5) form-field max-length enforcement. In some embodiments, the application firewall **290** ensures cookies are not modified. In other embodiments, the application firewall **290** protects against forceful browsing by enforcing legal URLs.

In still yet other embodiments, the application firewall **290** protects any confidential information contained in the network communication. The application firewall **290** may inspect or analyze any network communication in accordance with the rules or policies of the engine **236** to identify any confidential information in any field of the network packet. In some embodiments, the application firewall **290** identifies in the network communication one or more occurrences of a credit card number, password, social security number, name, patient code, contact information, and age. The encoded portion of the network communication may comprise these occurrences or the confidential information. Based on these occurrences, in one embodiment, the application firewall **290** may take a policy action on the network communication, such as prevent transmission of the network communication. In another embodiment, the application firewall **290** may rewrite, remove or otherwise mask such identified occurrence or confidential information.

Still referring to FIG. 2B, the appliance **200** may include a performance monitoring agent **197** as discussed above in conjunction with FIG. 1D. In one embodiment, the appliance **200** receives the monitoring agent **197** from the monitoring service **198** or monitoring server **106** as depicted in FIG. 1D. In some embodiments, the appliance **200** stores the monitoring agent **197** in storage, such as disk, for delivery to any client or server in communication with the appliance **200**. For example, in one embodiment, the appliance **200** transmits the monitoring agent **197** to a client upon receiving a request to establish a transport layer connection. In other embodiments, the appliance **200** transmits the monitoring agent **197** upon establishing the transport layer connection with the client **102**. In another embodiment, the appliance **200** transmits the monitoring agent **197** to the client upon intercepting or detecting a request for a web page. In yet another embodiment, the appliance **200** transmits the monitoring agent **197** to a client or a server in response to a request from the monitoring server **198**. In one embodiment, the appliance **200** transmits the monitoring agent **197** to a second appliance **200'** or appliance **205**.

In other embodiments, the appliance **200** executes the monitoring agent **197**. In one embodiment, the monitoring agent **197** measures and monitors the performance of any application, program, process, service, task or thread executing on the appliance **200**. For example, the monitoring agent **197** may monitor and measure performance and operation of vServers **275A-275N**. In another embodiment, the monitoring agent **197** measures and monitors the performance of any transport layer connections of the appliance **200**. In some embodiments, the monitoring agent **197** measures and monitors the performance of any user sessions traversing the appliance **200**. In one embodiment, the monitoring agent **197** measures and monitors the performance of any virtual private network connections and/or sessions traversing the appliance **200**, such as an SSL VPN session. In still further embodiments, the monitoring agent **197** measures and monitors the memory, CPU and disk usage and performance of the appliance **200**. In yet another embodiment, the monitoring agent **197** measures and monitors the performance of any acceleration technique **288** performed by the appliance **200**, such as SSL offloading, connection pooling and multiplexing, caching, and compression. In some embodiments, the monitoring agent **197** mea-

sures and monitors the performance of any load balancing and/or content switching 284 performed by the appliance 200. In other embodiments, the monitoring agent 197 measures and monitors the performance of application firewall 290 protection and processing performed by the appliance 200.

C. Client Agent

Referring now to FIG. 3, an embodiment of a client agent 120 is depicted. The client 102 includes a client agent 120 for establishing and exchanging communications with the appliance 200 and/or server 106 via a network 104. In brief overview, the client 102 operates on computing device 100 having an operating system with a kernel mode 302 and a user mode 303, and a network stack 310 with one or more layers 310a-310b. The client 102 may have installed and/or execute one or more applications. In some embodiments, one or more applications may communicate via the network stack 310 to a network 104. One of the applications, such as a web browser, may also include a first program 322. For example, the first program 322 may be used in some embodiments to install and/or execute the client agent 120, or any portion thereof. The client agent 120 includes an interception mechanism, or interceptor 350, for intercepting network communications from the network stack 310 from the one or more applications.

The network stack 310 of the client 102 may comprise any type and form of software, or hardware, or any combinations thereof, for providing connectivity to and communications with a network. In one embodiment, the network stack 310 comprises a software implementation for a network protocol suite. The network stack 310 may comprise one or more network layers, such as any networks layers of the Open Systems Interconnection (OSI) communications model as those skilled in the art recognize and appreciate. As such, the network stack 310 may comprise any type and form of protocols for any of the following layers of the OSI model: 1) physical link layer, 2) data link layer, 3) network layer, 4) transport layer, 5) session layer, 6) presentation layer, and 7) application layer. In one embodiment, the network stack 310 may comprise a transport control protocol (TCP) over the network layer protocol of the internet protocol (IP), generally referred to as TCP/IP. In some embodiments, the TCP/IP protocol may be carried over the Ethernet protocol, which may comprise any of the family of IEEE wide-area-network (WAN) or local-area-network (LAN) protocols, such as those protocols covered by the IEEE 802.3. In some embodiments, the network stack 310 comprises any type and form of a wireless protocol, such as IEEE 802.11 and/or mobile internet protocol.

In view of a TCP/IP based network, any TCP/IP based protocol may be used, including Messaging Application Programming Interface (MAPI) (email), File Transfer Protocol (FTP), HyperText Transfer Protocol (HTTP), Common Internet File System (CIFS) protocol (file transfer), Independent Computing Architecture (ICA) protocol, Remote Desktop Protocol (RDP), Wireless Application Protocol (WAP), Mobile IP protocol, and Voice Over IP (VoIP) protocol. In another embodiment, the network stack 310 comprises any type and form of transport control protocol, such as a modified transport control protocol, for example a Transaction TCP (T/TCP), TCP with selection acknowledgements (TCP-SACK), TCP with large windows (TCP-LW), a congestion prediction protocol such as the TCP-Vegas protocol, and a TCP spoofing protocol. In other embodiments, any type and form of user datagram protocol (UDP), such as UDP over IP, may be used by the network stack 310, such as for voice communications or real-time data communications.

Furthermore, the network stack 310 may include one or more network drivers supporting the one or more layers, such as a TCP driver or a network layer driver. The network drivers may be included as part of the operating system of the computing device 100 or as part of any network interface cards or other network access components of the computing device 100. In some embodiments, any of the network drivers of the network stack 310 may be customized, modified or adapted to provide a custom or modified portion of the network stack 310 in support of any of the techniques described herein. In other embodiments, the acceleration program 302 is designed and constructed to operate with or work in conjunction with the network stack 310 installed or otherwise provided by the operating system of the client 102.

The network stack 310 comprises any type and form of interfaces for receiving, obtaining, providing or otherwise accessing any information and data related to network communications of the client 102. In one embodiment, an interface to the network stack 310 comprises an application programming interface (API). The interface may also comprise any function call, hooking or filtering mechanism, event or call back mechanism, or any type of interfacing technique. The network stack 310 via the interface may receive or provide any type and form of data structure, such as an object, related to functionality or operation of the network stack 310. For example, the data structure may comprise information and data related to a network packet or one or more network packets. In some embodiments, the data structure comprises a portion of the network packet processed at a protocol layer of the network stack 310, such as a network packet of the transport layer. In some embodiments, the data structure 325 comprises a kernel-level data structure, while in other embodiments, the data structure 325 comprises a user-mode data structure. A kernel-level data structure may comprise a data structure obtained or related to a portion of the network stack 310 operating in kernel-mode 302, or a network driver or other software running in kernel-mode 302, or any data structure obtained or received by a service, process, task, thread or other executable instructions running or operating in kernel-mode of the operating system.

Additionally, some portions of the network stack 310 may execute or operate in kernel-mode 302, for example, the data link or network layer, while other portions execute or operate in user-mode 303, such as an application layer of the network stack 310. For example, a first portion 310a of the network stack may provide user-mode access to the network stack 310 to an application while a second portion 310b of the network stack 310 provides access to a network. In some embodiments, a first portion 310a of the network stack may comprise one or more upper layers of the network stack 310, such as any of layers 5-7. In other embodiments, a second portion 310b of the network stack 310 comprises one or more lower layers, such as any of layers 1-4. Each of the first portion 310a and second portion 310b of the network stack 310 may comprise any portion of the network stack 310, at any one or more network layers, in user-mode 303, kernel-mode, 302, or combinations thereof, or at any portion of a network layer or interface point to a network layer or any portion of or interface point to the user-mode 303 and kernel-mode 302.

The interceptor 350 may comprise software, hardware, or any combination of software and hardware. In one embodiment, the interceptor 350 intercepts a network communication at any point in the network stack 310, and redirects or transmits the network communication to a destination desired, managed or controlled by the interceptor 350 or client agent 120. For example, the interceptor 350 may intercept a network communication of a network stack 310 of a

first network and transmit the network communication to the appliance 200 for transmission on a second network 104. In some embodiments, the interceptor 350 comprises any type of network driver constructed and designed to interface and work with the network stack 310. In some embodiments, the client agent 120 and/or interceptor 350 operates at one or more layers of the network stack 310, such as at the transport layer. In one embodiment, the interceptor 350 comprises a filter driver, hooking mechanism, or any form and type of suitable network driver interface that interfaces to the transport layer of the network stack, such as via the transport driver interface (TDI). In some embodiments, the interceptor 350 interfaces to a first protocol layer, such as the transport layer and another protocol layer, such as any layer above the transport protocol layer, for example, an application protocol layer. In one embodiment, the interceptor 350 may comprise a driver complying with the Network Driver Interface Specification (NDIS), or a NDIS driver. In another embodiment, the interceptor 350 may comprise a mini-filter or a mini-port driver. In one embodiment, the interceptor 350, or portion thereof, operates in kernel-mode 302. In another embodiment, the interceptor 350, or portion thereof, operates in user-mode 303. In some embodiments, a portion of the interceptor 350 operates in kernel-mode 302 while another portion of the interceptor 350 operates in user-mode 303. In other embodiments, the client agent 120 operates in user-mode 303 but interfaces via the interceptor 350 to a kernel-mode driver, process, service, task or portion of the operating system, such as to obtain a kernel-level data structure 225. In further embodiments, the interceptor 350 is a user-mode application or program, such as application.

In one embodiment, the interceptor 350 intercepts any transport layer connection requests. In these embodiments, the interceptor 350 execute transport layer application programming interface (API) calls to set the destination information, such as destination IP address and/or port to a desired location for the location. In this manner, the interceptor 350 intercepts and redirects the transport layer connection to a IP address and port controlled or managed by the interceptor 350 or client agent 120. In one embodiment, the interceptor 350 sets the destination information for the connection to a local IP address and port of the client 102 on which the client agent 120 is listening. For example, the client agent 120 may comprise a proxy service listening on a local IP address and port for redirected transport layer communications. In some embodiments, the client agent 120 then communicates the redirected transport layer communication to the appliance 200.

In some embodiments, the interceptor 350 intercepts a Domain Name Service (DNS) request. In one embodiment, the client agent 120 and/or interceptor 350 resolves the DNS request. In another embodiment, the interceptor transmits the intercepted DNS request to the appliance 200 for DNS resolution. In one embodiment, the appliance 200 resolves the DNS request and communicates the DNS response to the client agent 120. In some embodiments, the appliance 200 resolves the DNS request via another appliance 200' or a DNS server 106.

In yet another embodiment, the client agent 120 may comprise two agents 120 and 120'. In one embodiment, a first agent 120 may comprise an interceptor 350 operating at the network layer of the network stack 310. In some embodiments, the first agent 120 intercepts network layer requests such as Internet Control Message Protocol (ICMP) requests (e.g., ping and traceroute). In other embodiments, the second agent 120' may operate at the transport layer and intercept

transport layer communications. In some embodiments, the first agent 120 intercepts communications at one layer of the network stack 310 and interfaces with or communicates the intercepted communication to the second agent 120'.

The client agent 120 and/or interceptor 350 may operate at or interface with a protocol layer in a manner transparent to any other protocol layer of the network stack 310. For example, in one embodiment, the interceptor 350 operates or interfaces with the transport layer of the network stack 310 transparently to any protocol layer below the transport layer, such as the network layer, and any protocol layer above the transport layer, such as the session, presentation or application layer protocols. This allows the other protocol layers of the network stack 310 to operate as desired and without modification for using the interceptor 350. As such, the client agent 120 and/or interceptor 350 can interface with the transport layer to secure, optimize, accelerate, route or load-balance any communications provided via any protocol carried by the transport layer, such as any application layer protocol over TCP/IP.

Furthermore, the client agent 120 and/or interceptor may operate at or interface with the network stack 310 in a manner transparent to any application, a user of the client 102, and any other computing device, such as a server, in communications with the client 102. The client agent 120 and/or interceptor 350 may be installed and/or executed on the client 102 in a manner without modification of an application. In some embodiments, the user of the client 102 or a computing device in communications with the client 102 are not aware of the existence, execution or operation of the client agent 120 and/or interceptor 350. As such, in some embodiments, the client agent 120 and/or interceptor 350 is installed, executed, and/or operated transparently to an application, user of the client 102, another computing device, such as a server, or any of the protocol layers above and/or below the protocol layer interfaced to by the interceptor 350.

The client agent 120 includes an acceleration program 302, a streaming client 306, a collection agent 304, and/or monitoring agent 197. In one embodiment, the client agent 120 comprises an Independent Computing Architecture (ICA) client, or any portion thereof, developed by Citrix Systems, Inc. of Fort Lauderdale, Fla., and is also referred to as an ICA client. In some embodiments, the client 120 comprises an application streaming client 306 for streaming an application from a server 106 to a client 102. In some embodiments, the client agent 120 comprises an acceleration program 302 for accelerating communications between client 102 and server 106. In another embodiment, the client agent 120 includes a collection agent 304 for performing end-point detection/scanning and collecting end-point information for the appliance 200 and/or server 106.

In some embodiments, the acceleration program 302 comprises a client-side acceleration program for performing one or more acceleration techniques to accelerate, enhance or otherwise improve a client's communications with and/or access to a server 106, such as accessing an application provided by a server 106. The logic, functions, and/or operations of the executable instructions of the acceleration program 302 may perform one or more of the following acceleration techniques: 1) multi-protocol compression, 2) transport control protocol pooling, 3) transport control protocol multiplexing, 4) transport control protocol buffering, and 5) caching via a cache manager. Additionally, the acceleration program 302 may perform encryption and/or decryption of any communications received and/or transmitted by the client 102. In some embodiments, the acceleration program 302 performs one or more of the acceleration techniques in an integrated manner

or fashion. Additionally, the acceleration program **302** can perform compression on any of the protocols, or multiple-protocols, carried as a payload of a network packet of the transport layer protocol.

The streaming client **306** comprises an application, program, process, service, task or executable instructions for receiving and executing a streamed application from a server **106**. A server **106** may stream one or more application data files to the streaming client **306** for playing, executing or otherwise causing to be executed the application on the client **102**. In some embodiments, the server **106** transmits a set of compressed or packaged application data files to the streaming client **306**. In some embodiments, the plurality of application files are compressed and stored on a file server within an archive file such as a CAB, ZIP, SIT, TAR, JAR or other archive. In one embodiment, the server **106** decompresses, unpackages or unarchives the application files and transmits the files to the client **102**. In another embodiment, the client **102** decompresses, unpackages or unarchives the application files. The streaming client **306** dynamically installs the application, or portion thereof, and executes the application. In one embodiment, the streaming client **306** may be an executable program. In some embodiments, the streaming client **306** may be able to launch another executable program.

The collection agent **304** comprises an application, program, process, service, task or executable instructions for identifying, obtaining and/or collecting information about the client **102**. In some embodiments, the appliance **200** transmits the collection agent **304** to the client **102** or client agent **120**. The collection agent **304** may be configured according to one or more policies of the policy engine **236** of the appliance. In other embodiments, the collection agent **304** transmits collected information on the client **102** to the appliance **200**. In one embodiment, the policy engine **236** of the appliance **200** uses the collected information to determine and provide access, authentication and authorization control of the client's connection to a network **104**.

In one embodiment, the collection agent **304** comprises an end-point detection and scanning mechanism, which identifies and determines one or more attributes or characteristics of the client. For example, the collection agent **304** may identify and determine any one or more of the following client-side attributes: 1) the operating system an/or a version of an operating system, 2) a service pack of the operating system, 3) a running service, 4) a running process, and 5) a file. The collection agent **304** may also identify and determine the presence or versions of any one or more of the following on the client: 1) antivirus software, 2) personal firewall software, 3) anti-spam software, and 4) internet security software. The policy engine **236** may have one or more policies based on any one or more of the attributes or characteristics of the client or client-side attributes.

In some embodiments, the client agent **120** includes a monitoring agent **197** as discussed in conjunction with FIGS. **1D** and **2B**. The monitoring agent **197** may be any type and form of script, such as Visual Basic or Java script. In one embodiment, the monitoring agent **197** monitors and measures performance of any portion of the client agent **120**. For example, in some embodiments, the monitoring agent **197** monitors and measures performance of the acceleration program **302**. In another embodiment, the monitoring agent **197** monitors and measures performance of the streaming client **306**. In other embodiments, the monitoring agent **197** monitors and measures performance of the collection agent **304**. In still another embodiment, the monitoring agent **197** monitors and measures performance of the interceptor **350**. In some

embodiments, the monitoring agent **197** monitors and measures any resource of the client **102**, such as memory, CPU and disk.

The monitoring agent **197** may monitor and measure performance of any application of the client. In one embodiment, the monitoring agent **197** monitors and measures performance of a browser on the client **102**. In some embodiments, the monitoring agent **197** monitors and measures performance of any application delivered via the client agent **120**. In other embodiments, the monitoring agent **197** measures and monitors end user response times for an application, such as web-based or HTTP response times. The monitoring agent **197** may monitor and measure performance of an ICA or RDP client. In another embodiment, the monitoring agent **197** measures and monitors metrics for a user session or application session. In some embodiments, monitoring agent **197** measures and monitors an ICA or RDP session. In one embodiment, the monitoring agent **197** measures and monitors the performance of the appliance **200** in accelerating delivery of an application and/or data to the client **102**.

In some embodiments, and still referring to FIG. **3**, a first program **322** may be used to install and/or execute the client agent **120**, or portion thereof, such as the interceptor **350**, automatically, silently, transparently, or otherwise. In one embodiment, the first program **322** comprises a plugin component, such as an ActiveX control or Java control or script that is loaded into and executed by an application. For example, the first program comprises an ActiveX control loaded and run by a web browser application, such as in the memory space or context of the application. In another embodiment, the first program **322** comprises a set of executable instructions loaded into and run by the application, such as a browser. In one embodiment, the first program **322** comprises a designed and constructed program to install the client agent **120**. In some embodiments, the first program **322** obtains, downloads, or receives the client agent **120** via the network from another computing device. In another embodiment, the first program **322** is an installer program or a plug and play manager for installing programs, such as network drivers, on the operating system of the client **102**.

D. Systems and Methods for Providing Virtualized Application Delivery Controller

Referring now to FIG. **4A**, a block diagram depicts one embodiment of a virtualization environment **400**. In brief overview, a computing device **100** includes a hypervisor layer, a virtualization layer, and a hardware layer. The hypervisor layer includes a hypervisor **401** (also referred to as a virtualization manager) that allocates and manages access to a number of physical resources in the hardware layer (e.g., the processor(s) **421**, and disk(s) **428**) by at least one virtual machine executing in the virtualization layer. The virtualization layer includes at least one operating system **410** and a plurality of virtual resources allocated to the at least one operating system **410**. Virtual resources may include, without limitation, a plurality of virtual processors **432a**, **432b**, **432c** (generally **432**), and virtual disks **442a**, **442b**, **442c** (generally **442**), as well as virtual resources such as virtual memory and virtual network interfaces. The plurality of virtual resources and the operating system **410** may be referred to as a virtual machine **406**. A virtual machine **406** may include a control operating system **405** in communication with the hypervisor **401** and used to execute applications for managing and configuring other virtual machines on the computing device **100**.

In greater detail, a hypervisor **401** may provide virtual resources to an operating system in any manner which simulates the operating system having access to a physical device. A hypervisor **401** may provide virtual resources to any num-

ber of guest operating systems **410a**, **410b** (generally **410**). In some embodiments, a computing device **100** executes one or more types of hypervisors. In these embodiments, hypervisors may be used to emulate virtual hardware, partition physical hardware, virtualize physical hardware, and execute virtual machines that provide access to computing environments. Hypervisors may include those manufactured by VMWare, Inc., of Palo Alto, Calif.; the XEN hypervisor, an open source product whose development is overseen by the open source Xen.org community; HyperV, VirtualServer or virtual PC hypervisors provided by Microsoft, or others. In some embodiments, a computing device **100** executing a hypervisor that creates a virtual machine platform on which guest operating systems may execute is referred to as a host server. In one of these embodiments, for example, the computing device **100** is a XEN SERVER provided by Citrix Systems, Inc., of Fort Lauderdale, Fla.

In some embodiments, a hypervisor **401** executes within an operating system executing on a computing device. In one of these embodiments, a computing device executing an operating system and a hypervisor **401** may be said to have a host operating system (the operating system executing on the computing device), and a guest operating system (an operating system executing within a computing resource partition provided by the hypervisor **401**). In other embodiments, a hypervisor **401** interacts directly with hardware on a computing device, instead of executing on a host operating system. In one of these embodiments, the hypervisor **401** may be said to be executing on “bare metal,” referring to the hardware comprising the computing device.

In some embodiments, a hypervisor **401** may create a virtual machine **406a-c** (generally **406**) in which an operating system **410** executes. In one of these embodiments, for example, the hypervisor **401** loads a virtual machine image to create a virtual machine **406**. In another of these embodiments, the hypervisor **401** executes an operating system **410** within the virtual machine **406**. In still another of these embodiments, the virtual machine **406** executes an operating system **410**.

In some embodiments, the hypervisor **401** controls processor scheduling and memory partitioning for a virtual machine **406** executing on the computing device **100**. In one of these embodiments, the hypervisor **401** controls the execution of at least one virtual machine **406**. In another of these embodiments, the hypervisor **401** presents at least one virtual machine **406** with an abstraction of at least one hardware resource provided by the computing device **100**. In other embodiments, the hypervisor **401** controls whether and how physical processor capabilities are presented to the virtual machine **406**.

A control operating system **405** may execute at least one application for managing and configuring the guest operating systems. In one embodiment, the control operating system **405** may execute an administrative application, such as an application including a user interface providing administrators with access to functionality for managing the execution of a virtual machine, including functionality for executing a virtual machine, terminating an execution of a virtual machine, or identifying a type of physical resource for allocation to the virtual machine. In another embodiment, the hypervisor **401** executes the control operating system **405** within a virtual machine **406** created by the hypervisor **401**. In still another embodiment, the control operating system **405** executes in a virtual machine **406** that is authorized to directly access physical resources on the computing device **100**. In some embodiments, a control operating system **405a** on a computing device **100a** may exchange data with a control

operating system **405b** on a computing device **100b**, via communications between a hypervisor **401a** and a hypervisor **401b**. In this way, one or more computing devices **100** may exchange data with one or more of the other computing devices **100** regarding processors and other physical resources available in a pool of resources. In one of these embodiments, this functionality allows a hypervisor to manage a pool of resources distributed across a plurality of physical computing devices. In another of these embodiments, multiple hypervisors manage one or more of the guest operating systems executed on one of the computing devices **100**.

In one embodiment, the control operating system **405** executes in a virtual machine **406** that is authorized to interact with at least one guest operating system **410**. In another embodiment, a guest operating system **410** communicates with the control operating system **405** via the hypervisor **401** in order to request access to a disk or a network. In still another embodiment, the guest operating system **410** and the control operating system **405** may communicate via a communication channel established by the hypervisor **401**, such as, for example, via a plurality of shared memory pages made available by the hypervisor **401**.

In some embodiments, the control operating system **405** includes a network back-end driver for communicating directly with networking hardware provided by the computing device **100**. In one of these embodiments, the network back-end driver processes at least one virtual machine request from at least one guest operating system **110**. In other embodiments, the control operating system **405** includes a block back-end driver for communicating with a storage element on the computing device **100**. In one of these embodiments, the block back-end driver reads and writes data from the storage element based upon at least one request received from a guest operating system **410**.

In one embodiment, the control operating system **405** includes a tools stack **404**. In another embodiment, a tools stack **404** provides functionality for interacting with the hypervisor **401**, communicating with other control operating systems **405** (for example, on a second computing device **100b**), or managing virtual machines **406b**, **406c** on the computing device **100**. In another embodiment, the tools stack **404** includes customized applications for providing improved management functionality to an administrator of a virtual machine farm. In some embodiments, at least one of the tools stack **404** and the control operating system **405** include a management API that provides an interface for remotely configuring and controlling virtual machines **406** running on a computing device **100**. In other embodiments, the control operating system **405** communicates with the hypervisor **401** through the tools stack **404**.

In one embodiment, the hypervisor **401** executes a guest operating system **410** within a virtual machine **406** created by the hypervisor **401**. In another embodiment, the guest operating system **410** provides a user of the computing device **100** with access to resources within a computing environment. In still another embodiment, a resource includes a program, an application, a document, a file, a plurality of applications, a plurality of files, an executable program file, a desktop environment, a computing environment, or other resource made available to a user of the computing device **100**. In yet another embodiment, the resource may be delivered to the computing device **100** via a plurality of access methods including, but not limited to, conventional installation directly on the computing device **100**, delivery to the computing device **100** via a method for application streaming, delivery to the computing device **100** of output data generated by an execution of the resource on a second computing device **100'** and communi-

cated to the computing device **100** via a presentation layer protocol, delivery to the computing device **100** of output data generated by an execution of the resource via a virtual machine executing on a second computing device **100'**, or execution from a removable storage device connected to the computing device **100**, such as a USB device, or via a virtual machine executing on the computing device **100** and generating output data. In some embodiments, the computing device **100** transmits output data generated by the execution of the resource to another computing device **100'**.

In one embodiment, the guest operating system **410**, in conjunction with the virtual machine on which it executes, forms a fully-virtualized virtual machine which is not aware that it is a virtual machine; such a machine may be referred to as a "Domain U HVM (Hardware Virtual Machine) virtual machine". In another embodiment, a fully-virtualized machine includes software emulating a Basic Input/Output System (BIOS) in order to execute an operating system within the fully-virtualized machine. In still another embodiment, a fully-virtualized machine may include a driver that provides functionality by communicating with the hypervisor **401**. In such an embodiment, the driver may be aware that it executes within a virtualized environment. In another embodiment, the guest operating system **410**, in conjunction with the virtual machine on which it executes, forms a paravirtualized virtual machine, which is aware that it is a virtual machine; such a machine may be referred to as a "Domain U PV virtual machine". In another embodiment, a paravirtualized machine includes additional drivers that a fully-virtualized machine does not include. In still another embodiment, the paravirtualized machine includes the network back-end driver and the block back-end driver included in a control operating system **405**, as described above.

Referring now to FIG. 4B, a block diagram depicts one embodiment of a plurality of networked computing devices in a system in which at least one physical host executes a virtual machine. In brief overview, the system includes a management component **404** and a hypervisor **401**. The system includes a plurality of computing devices **100**, a plurality of virtual machines **406**, a plurality of hypervisors **401**, a plurality of management components referred to variously as tools stacks **404** or management components **404**, and a physical resource **421**, **428**. The plurality of physical machines **100** may each be provided as computing devices **100**, described above in connection with FIGS. 1E-1H and **4A**.

In greater detail, a physical disk **428** is provided by a computing device **100** and stores at least a portion of a virtual disk **442**. In some embodiments, a virtual disk **442** is associated with a plurality of physical disks **428**. In one of these embodiments, one or more computing devices **100** may exchange data with one or more of the other computing devices **100** regarding processors and other physical resources available in a pool of resources, allowing a hypervisor to manage a pool of resources distributed across a plurality of physical computing devices. In some embodiments, a computing device **100** on which a virtual machine **406** executes is referred to as a physical host **100** or as a host machine **100**.

The hypervisor executes on a processor on the computing device **100**. The hypervisor allocates, to a virtual disk, an amount of access to the physical disk. In one embodiment, the hypervisor **401** allocates an amount of space on the physical disk. In another embodiment, the hypervisor **401** allocates a plurality of pages on the physical disk. In some embodiments, the hypervisor provisions the virtual disk **442** as part of a process of initializing and executing a virtual machine **450**.

In one embodiment, the management component **404a** is referred to as a pool management component **404a**. In another embodiment, a management operating system **405a**, which may be referred to as a control operating system **405a**, includes the management component. In some embodiments, the management component is referred to as a tools stack. In one of these embodiments, the management component is the tools stack **404** described above in connection with FIG. 4A. In other embodiments, the management component **404** provides a user interface for receiving, from a user such as an administrator, an identification of a virtual machine **406** to provision and/or execute. In still other embodiments, the management component **404** provides a user interface for receiving, from a user such as an administrator, the request for migration of a virtual machine **406b** from one physical machine **100** to another. In further embodiments, the management component **404a** identifies a computing device **100b** on which to execute a requested virtual machine **406d** and instructs the hypervisor **401b** on the identified computing device **100b** to execute the identified virtual machine; such a management component may be referred to as a pool management component.

Referring now to FIG. 4C, a diagram of an embodiment of a virtual appliance **450** operating on a hypervisor **401** of a server **106** is depicted. In brief overview, any of the functionality and/or embodiments of the appliance **200** (e.g., an application delivery controller) described above in connection with FIGS. 2A and 2B may be deployed in any embodiment of the virtualized environment described above in connection with FIGS. 4A and 4B. Instead of the functionality of the application delivery controller being deployed in the form of an appliance **200**, such functionality may be deployed in a virtualized environment **400** on any computing device **100**, such as a client **102**, server **106** or appliance **200**.

As with the appliance **200** of FIGS. 2A and 2B, the virtual appliance **450** may provide functionality for availability, performance, offload and security. For availability, the virtual appliance may perform load balancing between layers 4 and 7 of the network and may also perform intelligent service health monitoring. For performance increases via network traffic acceleration, the virtual appliance may perform caching and compression. To offload processing of any servers, the virtual appliance may perform connection multiplexing and pooling and/or SSL processing. For security, the virtual appliance may perform any of the application firewall functionality and SSL VPN function of appliance **200**.

Any of the modules of the appliance **200** as described in connection with FIG. 2A may be packaged, combined, designed or constructed in a form of the virtualized appliance delivery controller **450** deployable as one or more software modules or components executable in a virtualized environment **300** or non-virtualized environment on any server, such as an off the shelf server. For example, the virtual appliance may be provided in the form of an installation package to install on a computing device. With reference to FIG. 2A, any of the cache manager **232**, policy engine **236**, compression **238**, encryption engine **234**, packet engine **240**, GUI **210**, CLI **212**, shell services **214** and health monitoring programs **216** may be designed and constructed as a software component or module to run on any operating system of a computing device and/or of a virtualized environment **300**. Instead of using the encryption processor **260**, processor **262**, memory **264** and network stack **267** of the appliance **200**, the virtualized appliance **400** may use any of these resources as provided by the virtualized environment **400** or as otherwise available on the server **106**.

Still referring to FIG. 4C, and in brief overview, any one or more vServers 275A-275N may be in operation or executed in a virtualized environment 400 of any type of computing device 100, such as any server 106. Any of the modules or functionality of the appliance 200 described in connection with FIG. 2B may be designed and constructed to operate in either a virtualized or non-virtualized environment of a server. Any of the vServer 275, SSL VPN 280, Intranet UP 282, Switching 284, DNS 286, acceleration 288, App FW 280 and monitoring agent may be packaged, combined, designed or constructed in a form of application delivery controller 450 deployable as one or more software modules or components executable on a device and/or virtualized environment 400.

In some embodiments, a server may execute multiple virtual machines 406a-406n in the virtualization environment with each virtual machine running the same or different embodiments of the virtual application delivery controller 450. In some embodiments, the server may execute one or more virtual appliances 450 on one or more virtual machines on a core of a multi-core processing system. In some embodiments, the server may execute one or more virtual appliances 450 on one or more virtual machines on each processor of a multiple processor device.

E. Systems and Methods for Providing a Multi-Core Architecture

In accordance with Moore's Law, the number of transistors that may be placed on an integrated circuit may double approximately every two years. However, CPU speed increases may reach plateaus, for example CPU speed has been around 3.5-4 GHz range since 2005. In some cases, CPU manufacturers may not rely on CPU speed increases to gain additional performance. Some CPU manufacturers may add additional cores to their processors to provide additional performance. Products, such as those of software and networking vendors, that rely on CPUs for performance gains may improve their performance by leveraging these multi-core CPUs. The software designed and constructed for a single CPU may be redesigned and/or rewritten to take advantage of a multi-threaded, parallel architecture or otherwise a multi-core architecture.

A multi-core architecture of the appliance 200, referred to as nCore or multi-core technology, allows the appliance in some embodiments to break the single core performance barrier and to leverage the power of multi-core CPUs. In the previous architecture described in connection with FIG. 2A, a single network or packet engine is run. The multiple cores of the nCore technology and architecture allow multiple packet engines to run concurrently and/or in parallel. With a packet engine running on each core, the appliance architecture leverages the processing capacity of additional cores. In some embodiments, this provides up to a 7x increase in performance and scalability.

Illustrated in FIG. 5A are some embodiments of work, task, load or network traffic distribution across one or more processor cores according to a type of parallelism or parallel computing scheme, such as functional parallelism, data parallelism or flow-based data parallelism. In brief overview, FIG. 5A illustrates embodiments of a multi-core system such as an appliance 200' with n-cores, a total of cores numbers 1 through N. In one embodiment, work, load or network traffic can be distributed among a first core 505A, a second core 505B, a third core 505C, a fourth core 505D, a fifth core 505E, a sixth core 505F, a seventh core 505G, and so on such that distribution is across all or two or more of the n cores 505N (hereinafter referred to collectively as cores 505.) There may be multiple virtual internet protocol servers (VIPs) 275 each running on a respective core of the plurality of cores. There

may be multiple packet engines 240 each running on a respective core of the plurality of cores. Any of the approaches used may lead to different, varying or similar work load or performance level 515 across any of the cores. For a functional parallelism approach, each core may run a different function of the functionalities provided by the packet engine, a VIP 275 or appliance 200. In a data parallelism approach, data may be paralleled or distributed across the cores based on the Network Interface Card (NIC) or VIP 275 receiving the data. In another data parallelism approach, processing may be distributed across the cores by distributing data flows to each core.

In further detail to FIG. 5A, in some embodiments, load, work or network traffic can be distributed among cores 505 according to functional parallelism 500. Functional parallelism may be based on each core performing one or more respective functions. In some embodiments, a first core may perform a first function while a second core performs a second function. In functional parallelism approach, the functions to be performed by the multi-core system are divided and distributed to each core according to functionality. In some embodiments, functional parallelism may be referred to as task parallelism and may be achieved when each processor or core executes a different process or function on the same or different data. The core or processor may execute the same or different code. In some cases, different execution threads or code may communicate with one another as they work. Communication may take place to pass data from one thread to the next as part of a workflow.

In some embodiments, distributing work across the cores 505 according to functional parallelism 500, can comprise distributing network traffic according to a particular function such as network input/output management (NW I/O) 510A, secure sockets layer (SSL) encryption and decryption 510B and transmission control protocol (TCP) functions 510C. This may lead to a work, performance or computing load 515 based on a volume or level of functionality being used. In some embodiments, distributing work across the cores 505 according to data parallelism 540, can comprise distributing an amount of work 515 based on distributing data associated with a particular hardware or software component. In some embodiments, distributing work across the cores 505 according to flow-based data parallelism 520, can comprise distributing data based on a context or flow such that the amount of work 515A-N on each core may be similar, substantially equal or relatively evenly distributed.

In the case of the functional parallelism approach, each core may be configured to run one or more functionalities of the plurality of functionalities provided by the packet engine or VIP of the appliance. For example, core 1 may perform network I/O processing for the appliance 200' while core 2 performs TCP connection management for the appliance. Likewise, core 3 may perform SSL offloading while core 4 may perform layer 7 or application layer processing and traffic management. Each of the cores may perform the same function or different functions. Each of the cores may perform more than one function. Any of the cores may run any of the functionality or portions thereof identified and/or described in conjunction with FIGS. 2A and 2B. In this approach, the work across the cores may be divided by function in either a coarse-grained or fine-grained manner. In some cases, as illustrated in FIG. 5A, division by function may lead to different cores running at different levels of performance or load 515.

In the case of the functional parallelism approach, each core may be configured to run one or more functionalities of the plurality of functionalities provided by the packet engine

of the appliance. For example, core 1 may perform network I/O processing for the appliance **200'** while core 2 performs TCP connection management for the appliance. Likewise, core 3 may perform SSL offloading while core 4 may perform layer 7 or application layer processing and traffic management. Each of the cores may perform the same function or different functions. Each of the cores may perform more than one function. Any of the cores may run any of the functionality or portions thereof identified and/or described in conjunction with FIGS. **2A** and **2B**. In this approach, the work across the cores may be divided by function in either a coarse-grained or fine-grained manner. In some cases, as illustrated in FIG. **5A** division by function may lead to different cores running at different levels of load or performance.

The functionality or tasks may be distributed in any arrangement and scheme. For example, FIG. **5B** illustrates a first core, Core 1 **505A**, processing applications and processes associated with network I/O functionality **510A**. Network traffic associated with network I/O, in some embodiments, can be associated with a particular port number. Thus, outgoing and incoming packets having a port destination associated with NW I/O **510A** will be directed towards Core 1 **505A** which is dedicated to handling all network traffic associated with the NW I/O port. Similarly, Core 2 **505B** is dedicated to handling functionality associated with SSL processing and Core 4 **505D** may be dedicated handling all TCP level processing and functionality.

While FIG. **5A** illustrates functions such as network I/O, SSL and TCP, other functions can be assigned to cores. These other functions can include any one or more of the functions or operations described herein. For example, any of the functions described in conjunction with FIGS. **2A** and **2B** may be distributed across the cores on a functionality basis. In some cases, a first VIP **275A** may run on a first core while a second VIP **275B** with a different configuration may run on a second core. In some embodiments, each core **505** can handle a particular functionality such that each core **505** can handle the processing associated with that particular function. For example, Core 2 **505B** may handle SSL offloading while Core 4 **505D** may handle application layer processing and traffic management.

In other embodiments, work, load or network traffic may be distributed among cores **505** according to any type and form of data parallelism **540**. In some embodiments, data parallelism may be achieved in a multi-core system by each core performing the same task or functionally on different pieces of distributed data. In some embodiments, a single execution thread or code controls operations on all pieces of data. In other embodiments, different threads or instructions control the operation, but may execute the same code. In some embodiments, data parallelism is achieved from the perspective of a packet engine, vServers (VIPs) **275A-C**, network interface cards (NIC) **542D-E** and/or any other networking hardware or software included on or associated with an appliance **200**. For example, each core may run the same packet engine or VIP code or configuration but operate on different sets of distributed data. Each networking hardware or software construct can receive different, varying or substantially the same amount of data, and as a result may have varying, different or relatively the same amount of load **515**.

In the case of a data parallelism approach, the work may be divided up and distributed based on VIPs, NICs and/or data flows of the VIPs or NICs. In one of these approaches, the work of the multi-core system may be divided or distributed among the VIPs by having each VIP work on a distributed set of data. For example, each core may be configured to run one or more VIPs. Network traffic may be distributed to the core

for each VIP handling that traffic. In another of these approaches, the work of the appliance may be divided or distributed among the cores based on which NIC receives the network traffic. For example, network traffic of a first NIC may be distributed to a first core while network traffic of a second NIC may be distributed to a second core. In some cases, a core may process data from multiple NICs.

While FIG. **5A** illustrates a single vServer associated with a single core **505**, as is the case for VIP1 **275A**, VIP2 **275B** and VIP3 **275C**. In some embodiments, a single vServer can be associated with one or more cores **505**. In contrast, one or more vServers can be associated with a single core **505**. Associating a vServer with a core **505** may include that core **505** to process all functions associated with that particular vServer. In some embodiments, each core executes a VIP having the same code and configuration. In other embodiments, each core executes a VIP having the same code but different configuration. In some embodiments, each core executes a VIP having different code and the same or different configuration.

Like vServers, NICs can also be associated with particular cores **505**. In many embodiments, NICs can be connected to one or more cores **505** such that when a NIC receives or transmits data packets, a particular core **505** handles the processing involved with receiving and transmitting the data packets. In one embodiment, a single NIC can be associated with a single core **505**, as is the case with NIC1 **542D** and NIC2 **542E**. In other embodiments, one or more NICs can be associated with a single core **505**. In other embodiments, a single NIC can be associated with one or more cores **505**. In these embodiments, load could be distributed amongst the one or more cores **505** such that each core **505** processes a substantially similar amount of load. A core **505** associated with a NIC may process all functions and/or data associated with that particular NIC.

While distributing work across cores based on data of VIPs or NICs may have a level of independency, in some embodiments, this may lead to unbalanced use of cores as illustrated by the varying loads **515** of FIG. **5A**.

In some embodiments, load, work or network traffic can be distributed among cores **505** based on any type and form of data flow. In another of these approaches, the work may be divided or distributed among cores based on data flows. For example, network traffic between a client and a server traversing the appliance may be distributed to and processed by one core of the plurality of cores. In some cases, the core initially establishing the session or connection may be the core for which network traffic for that session or connection is distributed. In some embodiments, the data flow is based on any unit or portion of network traffic, such as a transaction, a request/response communication or traffic originating from an application on a client. In this manner and in some embodiments, data flows between clients and servers traversing the appliance **200'** may be distributed in a more balanced manner than the other approaches.

In flow-based data parallelism **520**, distribution of data is related to any type of flow of data, such as request/response pairings, transactions, sessions, connections or application communications. For example, network traffic between a client and a server traversing the appliance may be distributed to and processed by one core of the plurality of cores. In some cases, the core initially establishing the session or connection may be the core for which network traffic for that session or connection is distributed. The distribution of data flow may be such that each core **505** carries a substantially equal or relatively evenly distributed amount of load, data or network traffic.

In some embodiments, the data flow is based on any unit or portion of network traffic, such as a transaction, a request/response communication or traffic originating from an application on a client. In this manner and in some embodiments, data flows between clients and servers traversing the appliance **200** may be distributed in a more balanced manner than the other approaches. In one embodiment, data flow can be distributed based on a transaction or a series of transactions. This transaction, in some embodiments, can be between a client and a server and can be characterized by an IP address or other packet identifier. For example, Core **1 505A** can be dedicated to transactions between a particular client and a particular server, therefore the load **515A** on Core **1 505A** may be comprised of the network traffic associated with the transactions between the particular client and server. Allocating the network traffic to Core **1 505A** can be accomplished by routing all data packets originating from either the particular client or server to Core **1 505A**.

While work or load can be distributed to the cores based in part on transactions, in other embodiments load or work can be allocated on a per packet basis. In these embodiments, the appliance **200** can intercept data packets and allocate them to a core **505** having the least amount of load. For example, the appliance **200** could allocate a first incoming data packet to Core **1 505A** because the load **515A** on Core **1** is less than the load **515B-N** on the rest of the cores **505B-N**. Once the first data packet is allocated to Core **1 505A**, the amount of load **515A** on Core **1 505A** is increased proportional to the amount of processing resources needed to process the first data packet. When the appliance **200** intercepts a second data packet, the appliance **200** will allocate the load to Core **4 505D** because Core **4 505D** has the second least amount of load. Allocating data packets to the core with the least amount of load can, in some embodiments, ensure that the load **515A-N** distributed to each core **505** remains substantially equal.

In other embodiments, load can be allocated on a per unit basis where a section of network traffic is allocated to a particular core **505**. The above-mentioned example illustrates load balancing on a per packet basis. In other embodiments, load can be allocated based on a number of packets such that every 10, 100 or 1000 packets are allocated to the core **505** having the least amount of load. The number of packets allocated to a core **505** can be a number determined by an application, user or administrator and can be any number greater than zero. In still other embodiments, load can be allocated based on a time metric such that packets are distributed to a particular core **505** for a predetermined amount of time. In these embodiments, packets can be distributed to a particular core **505** for five milliseconds or for any period of time determined by a user, program, system, administrator or otherwise. After the predetermined time period elapses, data packets are transmitted to a different core **505** for the predetermined period of time.

Flow-based data parallelism methods for distributing work, load or network traffic among the one or more cores **505** can comprise any combination of the above-mentioned embodiments. These methods can be carried out by any part of the appliance **200**, by an application or set of executable instructions executing on one of the cores **505**, such as the packet engine, or by any application, program or agent executing on a computing device in communication with the appliance **200**.

The functional and data parallelism computing schemes illustrated in FIG. **5A** can be combined in any manner to generate a hybrid parallelism or distributed processing scheme that encompasses function parallelism **500**, data par-

allelism **540**, flow-based data parallelism **520** or any portions thereof. In some cases, the multi-core system may use any type and form of load balancing schemes to distribute load among the one or more cores **505**. The load balancing scheme may be used in any combination with any of the functional and data parallelism schemes or combinations thereof.

Illustrated in FIG. **5B** is an embodiment of a multi-core system **545**, which may be any type and form of one or more systems, appliances, devices or components. This system **545**, in some embodiments, can be included within an appliance **200** having one or more processing cores **505A-N**. The system **545** can further include one or more packet engines (PE) or packet processing engines (PPE) **548A-N** communicating with a memory bus **556**. The memory bus may be used to communicate with the one or more processing cores **505A-N**. Also included within the system **545** can be one or more network interface cards (NIC) **552** and a flow distributor **550** which can further communicate with the one or more processing cores **505A-N**. The flow distributor **550** can comprise a Receive Side Scaler (RSS) or Receive Side Scaling (RSS) module **560**.

Further referring to FIG. **5B**, and in more detail, in one embodiment the packet engine(s) **548A-N** can comprise any portion of the appliance **200** described herein, such as any portion of the appliance described in FIGS. **2A** and **2B**. The packet engine(s) **548A-N** can, in some embodiments, comprise any of the following elements: the packet engine **240**, a network stack **267**; a cache manager **232**; a policy engine **236**; a compression engine **238**; an encryption engine **234**; a GUI **210**; a CLI **212**; shell services **214**; monitoring programs **216**; and any other software or hardware element able to receive data packets from one of either the memory bus **556** or the one of more cores **505A-N**. In some embodiments, the packet engine(s) **548A-N** can comprise one or more vServers **275A-N**, or any portion thereof. In other embodiments, the packet engine(s) **548A-N** can provide any combination of the following functionalities: SSL VPN **280**; Intranet UP **282**; switching **284**; DNS **286**; packet acceleration **288**; App FW **280**; monitoring such as the monitoring provided by a monitoring agent **197**; functionalities associated with functioning as a TCP stack; load balancing; SSL offloading and processing; content switching; policy evaluation; caching; compression; encoding; decompression; decoding; application firewall functionalities; XML processing and acceleration; and SSL VPN connectivity.

The packet engine(s) **548A-N** can, in some embodiments, be associated with a particular server, user, client or network. When a packet engine **548** becomes associated with a particular entity, that packet engine **548** can process data packets associated with that entity. For example, should a packet engine **548** be associated with a first user, that packet engine **548** will process and operate on packets generated by the first user, or packets having a destination address associated with the first user. Similarly, the packet engine **548** may choose not to be associated with a particular entity such that the packet engine **548** can process and otherwise operate on any data packets not generated by that entity or destined for that entity.

In some instances, the packet engine(s) **548A-N** can be configured to carry out the any of the functional and/or data parallelism schemes illustrated in FIG. **5A**. In these instances, the packet engine(s) **548A-N** can distribute functions or data among the processing cores **505A-N** so that the distribution is according to the parallelism or distribution scheme. In some embodiments, a single packet engine(s) **548A-N** carries out a load balancing scheme, while in other embodiments one or more packet engine(s) **548A-N** carry out a load balancing scheme. Each core **505A-N**, in one embodiment, can be asso-

ciated with a particular packet engine **548** such that load balancing can be carried out by the packet engine. Load balancing may in this embodiment, require that each packet engine **548A-N** associated with a core **505** communicate with the other packet engines associated with cores so that the packet engines **548A-N** can collectively determine where to distribute load. One embodiment of this process can include an arbiter that receives votes from each packet engine for load. The arbiter can distribute load to each packet engine **548A-N** based in part on the age of the engine's vote and in some cases a priority value associated with the current amount of load on an engine's associated core **505**.

Any of the packet engines running on the cores may run in user mode, kernel or any combination thereof. In some embodiments, the packet engine operates as an application or program running in user or application space. In these embodiments, the packet engine may use any type and form of interface to access any functionality provided by the kernel. In some embodiments, the packet engine operates in kernel mode or as part of the kernel. In some embodiments, a first portion of the packet engine operates in user mode while a second portion of the packet engine operates in kernel mode. In some embodiments, a first packet engine on a first core executes in kernel mode while a second packet engine on a second core executes in user mode. In some embodiments, the packet engine or any portions thereof operates on or in conjunction with the NIC or any drivers thereof.

In some embodiments the memory bus **556** can be any type and form of memory or computer bus. While a single memory bus **556** is depicted in FIG. **5B**, the system **545** can comprise any number of memory buses **556**. In one embodiment, each packet engine **548** can be associated with one or more individual memory buses **556**.

The NIC **552** can in some embodiments be any of the network interface cards or mechanisms described herein. The NIC **552** can have any number of ports. The NIC can be designed and constructed to connect to any type and form of network **104**. While a single NIC **552** is illustrated, the system **545** can comprise any number of NICs **552**. In some embodiments, each core **505A-N** can be associated with one or more single NICs **552**. Thus, each core **505** can be associated with a single NIC **552** dedicated to a particular core **505**. The cores **505A-N** can comprise any of the processors described herein. Further, the cores **505A-N** can be configured according to any of the core **505** configurations described herein. Still further, the cores **505A-N** can have any of the core **505** functionalities described herein. While FIG. **5B** illustrates seven cores **505A-G**, any number of cores **505** can be included within the system **545**. In particular, the system **545** can comprise "N" cores, where "N" is a whole number greater than zero.

A core may have or use memory that is allocated or assigned for use to that core. The memory may be considered private or local memory of that core and only accessible by that core. A core may have or use memory that is shared or assigned to multiple cores. The memory may be considered public or shared memory that is accessible by more than one core. A core may use any combination of private and public memory. With separate address spaces for each core, some level of coordination is eliminated from the case of using the same address space. With a separate address space, a core can perform work on information and data in the core's own address space without worrying about conflicts with other cores. Each packet engine may have a separate memory pool for TCP and/or SSL connections.

Further referring to FIG. **5B**, any of the functionality and/or embodiments of the cores **505** described above in connection with FIG. **5A** can be deployed in any embodiment of the

virtualized environment described above in connection with FIGS. **4A** and **4B**. Instead of the functionality of the cores **505** being deployed in the form of a physical processor **505**, such functionality may be deployed in a virtualized environment **400** on any computing device **100**, such as a client **102**, server **106** or appliance **200**. In other embodiments, instead of the functionality of the cores **505** being deployed in the form of an appliance or a single device, the functionality may be deployed across multiple devices in any arrangement. For example, one device may comprise two or more cores and another device may comprise two or more cores. For example, a multi-core system may include a cluster of computing devices, a server farm or network of computing devices. In some embodiments, instead of the functionality of the cores **505** being deployed in the form of cores, the functionality may be deployed on a plurality of processors, such as a plurality of single core processors.

In one embodiment, the cores **505** may be any type and form of processor. In some embodiments, a core can function substantially similar to any processor or central processing unit described herein. In some embodiment, the cores **505** may comprise any portion of any processor described herein. While FIG. **5A** illustrates seven cores, there can exist any "N" number of cores within an appliance **200**, where "N" is any whole number greater than one. In some embodiments, the cores **505** can be installed within a common appliance **200**, while in other embodiments the cores **505** can be installed within one or more appliance(s) **200** communicatively connected to one another. The cores **505** can in some embodiments comprise graphics processing software, while in other embodiments the cores **505** provide general processing capabilities. The cores **505** can be installed physically near each other and/or can be communicatively connected to each other. The cores may be connected by any type and form of bus or subsystem physically and/or communicatively coupled to the cores for transferring data between to, from and/or between the cores.

While each core **505** can comprise software for communicating with other cores, in some embodiments a core manager (not shown) can facilitate communication between each core **505**. In some embodiments, the kernel may provide core management. The cores may interface or communicate with each other using a variety of interface mechanisms. In some embodiments, core to core messaging may be used to communicate between cores, such as a first core sending a message or data to a second core via a bus or subsystem connecting the cores. In some embodiments, cores may communicate via any type and form of shared memory interface. In one embodiment, there may be one or more memory locations shared among all the cores. In some embodiments, each core may have separate memory locations shared with each other core. For example, a first core may have a first shared memory with a second core and a second share memory with a third core. In some embodiments, cores may communicate via any type of programming or API, such as function calls via the kernel. In some embodiments, the operating system may recognize and support multiple core devices and provide interfaces and API for inter-core communications.

The flow distributor **550** can be any application, program, library, script, task, service, process or any type and form of executable instructions executing on any type and form of hardware. In some embodiments, the flow distributor **550** can be any design and construction of circuitry to perform any of the operations and functions described herein. In some embodiments, the flow distributor distributes, forwards, routes, controls and/or manages the distribution of data packets among the cores **505** and/or packet engine or VIPs running

on the cores. The flow distributor **550**, in some embodiments, can be referred to as an interface master or manager. In one embodiment, the flow distributor **550** comprises a set of executable instructions executing on a core or processor of the appliance **200**. In another embodiment, the flow distributor **550** comprises a set of executable instructions executing on a computing machine in communication with the appliance **200**. In some embodiments, the flow distributor **550** comprises a set of executable instructions executing on a NIC, such as firmware. In still other embodiments, the flow distributor **550** comprises any combination of software and hardware to distribute data packets among cores or processors. In one embodiment, the flow distributor **550** executes on at least one of the cores **505A-N**, while in other embodiments a separate flow distributor **550** assigned to each core **505A-N** executes on an associated core **505A-N**. The flow distributor may use any type and form of statistical or probabilistic algorithms or decision making to balance the flows across the cores. The hardware of the appliance, such as a NIC, or the kernel may be designed and constructed to support sequential operations across the NICs and/or cores.

In embodiments where the system **545** comprises one or more flow distributors **550**, each flow distributor **550** can be associated with a processor **505** or a packet engine **548**. The flow distributors **550** can comprise an interface mechanism that allows each flow distributor **550** to communicate with the other flow distributors **550** executing within the system **545**. In one instance, the one or more flow distributors **550** can determine how to balance load by communicating with each other. This process can operate substantially similarly to the process described above for submitting votes to an arbiter which then determines which flow distributor **550** should receive the load. In other embodiments, a first flow distributor **550'** can identify the load on an associated core and determine whether to forward a first data packet to the associated core based on any of the following criteria: the load on the associated core is above a predetermined threshold; the load on the associated core is below a predetermined threshold; the load on the associated core is less than the load on the other cores; or any other metric that can be used to determine where to forward data packets based in part on the amount of load on a processor.

The flow distributor **550** can distribute network traffic among the cores **505** according to a distribution, computing or load balancing scheme such as those described herein. In one embodiment, the flow distributor can distribute network traffic according to any one of a functional parallelism distribution scheme **550**, a data parallelism load distribution scheme **540**, a flow-based data parallelism distribution scheme **520**, or any combination of these distribution scheme or any load balancing scheme for distributing load among multiple processors. The flow distributor **550** can therefore act as a load distributor by taking in data packets and distributing them across the processors according to an operative load balancing or distribution scheme. In one embodiment, the flow distributor **550** can comprise one or more operations, functions or logic to determine how to distribute packers, work or load accordingly. In still other embodiments, the flow distributor **550** can comprise one or more sub operations, functions or logic that can identify a source address and a destination address associated with a data packet, and distribute packets accordingly.

In some embodiments, the flow distributor **550** can comprise a receive-side scaling (RSS) network driver module or any type and form of executable instructions which distribute data packets among the one or more cores **505**. The RSS module can comprise any combination of hardware and soft-

ware. In some embodiments, the RSS module works in conjunction with the flow distributor **550** to distribute data packets across the cores **505A-N** or among multiple processors in a multi-processor network. The RSS module can execute within the NIC **552** in some embodiments, and in other embodiments can execute on any one of the cores **505**.

In some embodiments, the RSS module uses the MICROSOFT receive-side-scaling (RSS) scheme. In one embodiment, RSS is a Microsoft Scalable Networking initiative technology that enables receive processing to be balanced across multiple processors in the system while maintaining in-order delivery of the data. The RSS may use any type and form of hashing scheme to determine a core or processor for processing a network packet.

The RSS module can apply any type and form hash function such as the Toeplitz hash function. The hash function may be applied to the hash type or any the sequence of values. The hash function may be a secure hash of any security level or is otherwise cryptographically secure. The hash function may use a hash key. The size of the key is dependent upon the hash function. For the Toeplitz hash, the size may be 40 bytes for IPv6 and 16 bytes for IPv4.

The hash function may be designed and constructed based on any one or more criteria or design goals. In some embodiments, a hash function may be used that provides an even distribution of hash result for different hash inputs and different hash types, including TCP/IPv4, TCP/IPv6, IPv4, and IPv6 headers. In some embodiments, a hash function may be used that provides a hash result that is evenly distributed when a small number of buckets are present (for example, two or four). In some embodiments, hash function may be used that provides a hash result that is randomly distributed when a large number of buckets were present (for example, 64 buckets). In some embodiments, the hash function is determined based on a level of computational or resource usage. In some embodiments, the hash function is determined based on ease or difficulty of implementing the hash in hardware. In some embodiments, the hash function is determined based on the ease or difficulty of a malicious remote host to send packets that would all hash to the same bucket.

The RSS module may generate hashes from any type and form of input, such as a sequence of values. This sequence of values can include any portion of the network packet, such as any header, field or payload of network packet, or portions thereof. In some embodiments, the input to the hash may be referred to as a hash type and include any tuples of information associated with a network packet or data flow, such as any of the following: a four tuple comprising at least two IP addresses and two ports; a four tuple comprising any four sets of values; a six tuple; a two tuple; and/or any other sequence of numbers or values. The following are example of hash types that may be used by RSS:

4-tuple of source TCP Port, source IP version 4 (IPv4) address, destination TCP Port, and destination IPv4 address.

4-tuple of source TCP Port, source IP version 6 (IPv6) address, destination TCP Port, and destination IPv6 address.

2-tuple of source IPv4 address, and destination IPv4 address.

2-tuple of source IPv6 address, and destination IPv6 address.

2-tuple of source IPv6 address, and destination IPv6 address, including support for parsing IPv6 extension headers.

The hash result or any portion thereof may used to identify a core or entity, such as a packet engine or VIP, for distributing

a network packet. In some embodiments, one or more hash bits or mask are applied to the hash result. The hash bit or mask may be any number of bits or bytes. A NIC may support any number of bits, such as seven bits. The network stack may set the actual number of bits to be used during initialization. The number will be between 1 and 7, inclusive.

The hash result may be used to identify the core or entity via any type and form of table, such as a bucket table or indirection table. In some embodiments, the number of hash-result bits are used to index into the table. The range of the hash mask may effectively define the size of the indirection table. Any portion of the hash result or the hash result itself may be used to index the indirection table. The values in the table may identify any of the cores or processor, such as by a core or processor identifier. In some embodiments, all of the cores of the multi-core system are identified in the table. In other embodiments, a part of the cores of the multi-core system are identified in the table. The indirection table may comprise any number of buckets for example 2 to 128 buckets that may be indexed by a hash mask. Each bucket may comprise a range of index values that identify a core or processor. In some embodiments, the flow controller and/or RSS module may rebalance the network load by changing the indirection table.

In some embodiments, the multi-core system **545** does not include a RSS driver or RSS module. In some of these embodiments, a software steering module (not shown) or a software embodiment of the RSS module within the system can operate in conjunction with or as part of the flow distributor **550** to steer packets to cores **505** within the multi-core system **545**.

The flow distributor **550**, in some embodiments, executes within any module or program on the appliance **200**, on any one of the cores **505** and on any one of the devices or components included within the multi-core system **545**. In some embodiments, the flow distributor **550** can execute on the first core **505A**, while in other embodiments the flow distributor **550** can execute on the NIC **552**. In still other embodiments, an instance of the flow distributor **550'** can execute on each core **505** included in the multi-core system **575**. In this embodiment, each instance of the flow distributor **550'** can communicate with other instances of the flow distributor **550'** to forward packets back and forth across the cores **505**. There exist situations where a response to a request packet may not be processed by the same core, i.e. the first core processes the request while the second core processes the response. In these situations, the instances of the flow distributor **550'** can intercept the packet and forward it to the desired or correct core **505**, i.e. a flow distributor instance **550'** can forward the response to the first core. Multiple instances of the flow distributor **550'** can execute on any number of cores **505** and any combination of cores **505**.

The flow distributor may operate responsive to any one or more rules or policies. The rules may identify a core or packet processing engine to receive a network packet, data or data flow. The rules may identify any type and form of tuple information related to a network packet, such as a 4-tuple of source and destination IP address and source and destination ports. Based on a received packet matching the tuple specified by the rule, the flow distributor may forward the packet to a core or packet engine. In some embodiments, the packet is forwarded to a core via shared memory and/or core to core messaging.

Although FIG. **5B** illustrates the flow distributor **550** as executing within the multi-core system **545**, in some embodiments the flow distributor **550** can execute on a computing device or appliance remotely located from the multi-core

system **545**. In such an embodiment, the flow distributor **550** can communicate with the multi-core system **545** to take in data packets and distribute the packets across the one or more cores **505**. The flow distributor **550** can, in one embodiment, receive data packets destined for the appliance **200**, apply a distribution scheme to the received data packets and distribute the data packets to the one or more cores **505** of the multi-core system **545**. In one embodiment, the flow distributor **550** can be included in a router or other appliance such that the router can target particular cores **505** by altering meta data associated with each packet so that each packet is targeted towards a sub-node of the multi-core system **55**. In such an embodiment, CISCO's vn-tag mechanism can be used to alter or tag each packet with the appropriate meta data.

Illustrated in FIG. **5C** is an embodiment of a multi-core system **575** comprising one or more processing cores **505A-N**. In brief overview, one of the cores **505** can be designated as a control core **505A** and can be used as a control plane **570** for the other cores **505**. The other cores may be secondary cores which operate in a data plane while the control core provides the control plane. The cores **505A-N** may share a global cache **580**. While the control core provides a control plane, the other cores in the multi-core system form or provide a data plane. These cores perform data processing functionality on network traffic while the control provides initialization, configuration and control of the multi-core system.

Further referring to FIG. **5C**, and in more detail, the cores **505A-N** as well as the control core **505A** can be any processor described herein. Furthermore, the cores **505A-N** and the control core **505A** can be any processor able to function within the system **575** described in FIG. **5C**. Still further, the cores **505A-N** and the control core **505A** can be any core or group of cores described herein. The control core may be a different type of core or processor than the other cores. In some embodiments, the control may operate a different packet engine or have a packet engine configured differently than the packet engines of the other cores.

Any portion of the memory of each of the cores may be allocated to or used for a global cache that is shared by the cores. In brief overview, a predetermined percentage or predetermined amount of each of the memory of each core may be used for the global cache. For example, 50% of each memory of each core may be dedicated or allocated to the shared global cache. That is, in the illustrated embodiment, 2 GB of each core excluding the control plane core or core 1 may be used to form a 28 GB shared global cache. The configuration of the control plane such as via the configuration services may determine the amount of memory used for the shared global cache. In some embodiments, each core may provide a different amount of memory for use by the global cache. In other embodiments, any one core may not provide any memory or use the global cache. In some embodiments, any of the cores may also have a local cache in memory not allocated to the global shared memory. Each of the cores may store any portion of network traffic to the global shared cache. Each of the cores may check the cache for any content to use in a request or response. Any of the cores may obtain content from the global shared cache to use in a data flow, request or response.

The global cache **580** can be any type and form of memory or storage element, such as any memory or storage element described herein. In some embodiments, the cores **505** may have access to a predetermined amount of memory (i.e. 32 GB or any other memory amount commensurate with the system **575**). The global cache **580** can be allocated from that predetermined amount of memory while the rest of the available memory can be allocated among the cores **505**. In other

embodiments, each core 505 can have a predetermined amount of memory. The global cache 580 can comprise an amount of the memory allocated to each core 505. This memory amount can be measured in bytes, or can be measured as a percentage of the memory allocated to each core 505. Thus, the global cache 580 can comprise 1 GB of memory from the memory associated with each core 505, or can comprise 20 percent or one-half of the memory associated with each core 505. In some embodiments, only a portion of the cores 505 provide memory to the global cache 580, while in other embodiments the global cache 580 can comprise memory not allocated to the cores 505.

Each core 505 can use the global cache 580 to store network traffic or cache data. In some embodiments, the packet engines of the core use the global cache to cache and use data stored by the plurality of packet engines. For example, the cache manager of FIG. 2A and cache functionality of FIG. 2B may use the global cache to share data for acceleration. For example, each of the packet engines may store responses, such as HTML data, to the global cache. Any of the cache managers operating on a core may access the global cache to server caches responses to client requests.

In some embodiments, the cores 505 can use the global cache 580 to store a port allocation table which can be used to determine data flow based in part on ports. In other embodiments, the cores 505 can use the global cache 580 to store an address lookup table or any other table or list that can be used by the flow distributor to determine where to direct incoming and outgoing data packets. The cores 505 can, in some embodiments read from and write to cache 580, while in other embodiments the cores 505 can only read from or write to cache 580. The cores may use the global cache to perform core to core communications.

The global cache 580 may be sectioned into individual memory sections where each section can be dedicated to a particular core 505. In one embodiment, the control core 505A can receive a greater amount of available cache, while the other cores 505 can receiving varying amounts or access to the global cache 580.

In some embodiments, the system 575 can comprise a control core 505A. While FIG. 5C illustrates core 1 505A as the control core, the control core can be any core within the appliance 200 or multi-core system. Further, while only a single control core is depicted, the system 575 can comprise one or more control cores each having a level of control over the system. In some embodiments, one or more control cores can each control a particular aspect of the system 575. For example, one core can control deciding which distribution scheme to use, while another core can determine the size of the global cache 580.

The control plane of the multi-core system may be the designation and configuration of a core as the dedicated management core or as a master core. This control plane core may provide control, management and coordination of operation and functionality the plurality of cores in the multi-core system. This control plane core may provide control, management and coordination of allocation and use of memory of the system among the plurality of cores in the multi-core system, including initialization and configuration of the same. In some embodiments, the control plane includes the flow distributor for controlling the assignment of data flows to cores and the distribution of network packets to cores based on data flows. In some embodiments, the control plane core runs a packet engine and in other embodiments, the control plane core is dedicated to management and control of the other cores of the system.

The control core 505A can exercise a level of control over the other cores 505 such as determining how much memory should be allocated to each core 505 or determining which core 505 should be assigned to handle a particular function or hardware/software entity. The control core 505A, in some embodiments, can exercise control over those cores 505 within the control plane 570. Thus, there can exist processors outside of the control plane 570 which are not controlled by the control core 505A. Determining the boundaries of the control plane 570 can include maintaining, by the control core 505A or agent executing within the system 575, a list of those cores 505 controlled by the control core 505A. The control core 505A can control any of the following: initialization of a core; determining when a core is unavailable; re-distributing load to other cores 505 when one core fails; determining which distribution scheme to implement; determining which core should receive network traffic; determining how much cache should be allocated to each core; determining whether to assign a particular function or element to a particular core; determining whether to permit cores to communicate with one another; determining the size of the global cache 580; and any other determination of a function, configuration or operation of the cores within the system 575.

F. Systems and Methods for Providing a Distributed Cluster Architecture

As discussed in the previous section, to overcome limitations on transistor spacing and CPU speed increases, many CPU manufacturers have incorporated multi-core CPUs to improve performance beyond that capable of even a single, higher speed CPU. Similar or further performance gains may be made by operating a plurality of appliances, either single or multi-core, together as a distributed or clustered appliance. Individual computing devices or appliances may be referred to as nodes of the cluster. A centralized management system may perform load balancing, distribution, configuration, or other tasks to allow the nodes to operate in conjunction as a single computing system. Externally or to other devices, including servers and clients, in many embodiments, the cluster may be viewed as a single virtual appliance or computing device, albeit one with performance exceeding that of a typical individual appliance.

Referring now to FIG. 6, illustrated is an embodiment of a computing device cluster or appliance cluster 600. A plurality of appliances 200a-200n, or other computing devices, sometimes referred to as nodes, such as desktop computers, servers, rackmount servers, blade servers, or any other type and form of computing device may be joined into a single appliance cluster 600. Although referred to as an appliance cluster, in many embodiments, the cluster may operate as an application server, network storage server, backup service, or any other type of computing device without limitation. In many embodiments, the appliance cluster 600 may be used to perform many of the functions of appliances 200, WAN optimization devices, network acceleration devices, or other devices discussed above.

In some embodiments, the appliance cluster 600 may comprise a homogenous set of computing devices, such as identical appliances, blade servers within one or more chassis, desktop or rackmount computing devices, or other devices. In other embodiments, the appliance cluster 600 may comprise a heterogeneous or mixed set of devices, including different models of appliances, mixed appliances and servers, or any other set of computing devices. This may allow for an appliance cluster 600 to be expanded or upgraded over time with new models or devices, for example.

In some embodiments, each computing device or appliance 200 of an appliance cluster 600 may comprise a multi-core

appliance, as discussed above. In many such embodiments, the core management and flow distribution methods discussed above may be utilized by each individual appliance, in addition to the node management and distribution methods discussed herein. This may be thought of as a two-tier distributed system, with one appliance comprising and distributing data to multiple nodes, and each node comprising and distributing data for processing to multiple cores. Accordingly, in such embodiments, the node distribution system need not manage flow distribution to individual cores, as that may be taken care of by a master or control core as discussed above.

In many embodiments, an appliance cluster 600 may be physically grouped, such as a plurality of blade servers in a chassis or plurality of rackmount devices in a single rack, but in other embodiments, the appliance cluster 600 may be distributed in a plurality of chassis, plurality of racks, plurality of rooms in a data center, plurality of data centers, or any other physical arrangement. Accordingly, the appliance cluster 600 may be considered a virtual appliance, grouped via common configuration, management, and purpose, rather than a physical group.

In some embodiments, an appliance cluster 600 may be connected to one or more networks 104, 104'. For example, referring briefly back to FIG. 1A, in some embodiments, an appliance 200 may be deployed between a network 104 joined to one or more clients 102, and a network 104' joined to one or more servers 106. An appliance cluster 600 may be similarly deployed to operate as a single appliance. In many embodiments, this may not require any network topology changes external to appliance cluster 600, allowing for ease of installation and scalability from a single appliance scenario. In other embodiments, an appliance cluster 600 may be similarly deployed as shown in FIGS. 1B-1D or discussed above. In still other embodiments, an appliance cluster may comprise a plurality of virtual machines or processes executed by one or more servers. For example, in one such embodiment, a server farm may execute a plurality of virtual machines, each virtual machine configured as an appliance 200, and a plurality of the virtual machines acting in concert as an appliance cluster 600. In yet still other embodiments, an appliance cluster 600 may comprise a mix of appliances 200 or virtual machines configured as appliances 200. In some embodiments, appliance cluster 600 may be geographically distributed, with the plurality of appliances 200 not co-located. For example, referring back to FIG. 6, in one such embodiment, a first appliance 200a may be located at a first site, such as a data center and a second appliance 200b may be located at a second site, such as a central office or corporate headquarters. In a further embodiment, such geographically remote appliances may be joined by a dedicated network, such as a T1 or T3 point-to-point connection; a VPN; or any other type and form of network. Accordingly, although there may be additional communications latency compared to co-located appliances 200a-200b, there may be advantages in reliability in case of site power failures or communications outages, scalability, or other benefits. In some embodiments, latency issues may be reduced through geographic or network-based distribution of data flows. For example, although configured as an appliance cluster 600, communications from clients and servers at the corporate headquarters may be directed to the appliance 200b deployed at the site, load balancing may be weighted by location, or similar steps can be taken to mitigate any latency.

Still referring to FIG. 6, an appliance cluster 600 may be connected to a network via a client data plane 602. In some embodiments, client data plane 602 may comprise a commu-

nication network, such as a network 104, carrying data between clients and appliance cluster 600. In some embodiments, client data plane 602 may comprise a switch, hub, router, or other network devices bridging an external network 104 and the plurality of appliances 200a-200n of the appliance cluster 600. For example, in one such embodiment, a router may be connected to an external network 104, and connected to a network interface of each appliance 200a-200n. In some embodiments, this router or switch may be referred to as an interface manager or master, and may further be configured to distribute traffic evenly across the nodes in the application cluster 600. Thus, in many embodiments, the interface master may comprise a flow distributor external to appliance cluster 600. In other embodiments, the interface master may comprise one of appliances 200a-200n. For example, a first appliance 200a may serve as the interface master, receiving incoming traffic for the appliance cluster 600 and distributing the traffic across each of appliances 200b-200n. In some embodiments, return traffic may similarly flow from each of appliances 200b-200n via the first appliance 200a serving as the interface master. In other embodiments, return traffic from each of appliances 200b-200n may be transmitted directly to a network 104, 104', or via an external router, switch, or other device. In some embodiments, appliances 200 of the appliance cluster not serving as an interface master may be referred to as interface slaves.

The interface master may perform load balancing or traffic flow distribution in any of a variety of ways. For example, in some embodiments, the interface master may comprise a router performing equal-cost multi-path (ECMP) routing with nexthops configured with appliances or nodes of the cluster. The interface master may use an open-shortest path first (OSPF) In some embodiments, the interface master may use a stateless hash-based mechanism for traffic distribution, such as hashes based on IP address or other packet information tuples, as discussed above. Hash keys and/or salt may be selected for even distribution across the nodes. In other embodiments, the interface master may perform flow distribution via link aggregation (LAG) protocols, or any other type and form of flow distribution, load balancing, and routing.

In some embodiments, the appliance cluster 600 may be connected to a network via a server data plane 604. Similar to client data plane 602, server data plane 604 may comprise a communication network, such as a network 104', carrying data between servers and appliance cluster 600. In some embodiments, server data plane 604 may comprise a switch, hub, router, or other network devices bridging an external network 104' and the plurality of appliances 200a-200n of the appliance cluster 600. For example, in one such embodiment, a router may be connected to an external network 104', and connected to a network interface of each appliance 200a-200n. In many embodiments, each appliance 200a-200n may comprise multiple network interfaces, with a first network interface connected to client data plane 602 and a second network interface connected to server data plane 604. This may provide additional security and prevent direct interface of client and server networks by having appliance cluster 600 server as an intermediary device. In other embodiments, client data plane 602 and server data plane 604 may be merged or combined. For example, appliance cluster 600 may be deployed as a non-intermediary node on a network with clients 102 and servers 106. As discussed above, in many embodiments, an interface master may be deployed on the server data plane 604, for routing and distributing communications from the servers and network 104' to each appliance of

the appliance cluster. In many embodiments, an interface master for client data plane 602 and an interface master for server data plane 604 may be similarly configured, performing ECMP or LAG protocols as discussed above.

In some embodiments, each appliance 200a-200n in appliance cluster 600 may be connected via an internal communication network or back plane 606. Back plane 606 may comprise a communication network for inter-node or inter-appliance control and configuration messages, and for inter-node forwarding of traffic. For example, in one embodiment in which a first appliance 200a communicates with a client via network 104, and a second appliance 200b communicates with a server via network 104', communications between the client and server may flow from client to first appliance, from first appliance to second appliance via back plane 606, and from second appliance to server, and vice versa. In other embodiments, back plane 606 may carry configuration messages, such as interface pause or reset commands; policy updates such as filtering or compression policies; status messages such as buffer status, throughput, or error messages; or any other type and form of inter-node communication. In some embodiments, RSS keys or hash keys may be shared by all nodes in the cluster, and may be communicated via back plane 606. For example, a first node or master node may select an RSS key, such as at startup or boot, and may distribute this key for use by other nodes. In some embodiments, back plane 606 may comprise a network between network interfaces of each appliance 200, and may comprise a router, switch, or other network device (not illustrated). Thus, in some embodiments and as discussed above, a router for client data plane 602 may be deployed between appliance cluster 600 and network 104, a router for server data plane 604 may be deployed between appliance cluster 600 and network 104', and a router for back plane 606 may be deployed as part of appliance cluster 600. Each router may connect to a different network interface of each appliance 200. In other embodiments, one or more planes 602-606 may be combined, or a router or switch may be split into multiple LANs or VLANs to connect to different interfaces of appliances 200a-200n and serve multiple routing functions simultaneously, to reduce complexity or eliminate extra devices from the system.

In some embodiments, a control plane (not illustrated) may communicate configuration and control traffic from an administrator or user to the appliance cluster 600. In some embodiments, the control plane may be a fourth physical network, while in other embodiments, the control plane may comprise a VPN, tunnel, or communication via one of planes 602-606. Thus, the control plane may, in some embodiments, be considered a virtual communication plane. In other embodiments, an administrator may provide configuration and control through a separate interface, such as a serial communication interface such as RS-232; a USB communication interface; or any other type and form of communication. In some embodiments, an appliance 200 may comprise an interface for administration, such as a front panel with buttons and a display; a web server for configuration via network 104, 104' or back plane 606; or any other type and form of interface.

In some embodiments, as discussed above, appliance cluster 600 may include internal flow distribution. For example, this may be done to allow nodes to join/leave transparently to external devices. To prevent an external flow distributor from needing to be repeatedly reconfigured on such changes, a node or appliance may act as an interface master or distributor for steering network packets to the correct node within the cluster 600. For example, in some embodiments, when a node leaves the cluster (such as on failure, reset, or similar cases),

an external ECMP router may identify the change in nodes, and may rehash all flows to redistribute traffic. This may result in dropping and resetting all connections. The same drop and reset may occur when the node rejoins. In some embodiments, for reliability, two appliances or nodes within appliance cluster 600 may receive communications from external routers via connection mirroring.

In many embodiments, flow distribution among nodes of appliance cluster 600 may use any of the methods discussed above for flow distribution among cores of an appliance. For example, in one embodiment, a master appliance, master node, or interface master, may compute a RSS hash, such as a Toeplitz hash on incoming traffic and consult a preference list or distribution table for the hash. In many embodiments, the flow distributor may provide the hash to the recipient appliance when forwarding the traffic. This may eliminate the need for the node to recompute the hash for flow distribution to a core. In many such embodiments, the RSS key used for calculating hashes for distribution among the appliances may comprise the same key as that used for calculating hashes for distribution among the cores, which may be referred to as a global RSS key, allowing for reuse of the calculated hash. In some embodiments, the hash may be computed with input tuples of transport layer headers including port numbers, internet layer headers including IP addresses; or any other packet header information. In some embodiments, packet body information may be utilized for the hash. For example, in one embodiment in which traffic of one protocol is encapsulated within traffic of another protocol, such as lossy UDP traffic encapsulated via a lossless TCP header, the flow distributor may calculate the hash based on the headers of the encapsulated protocol (e.g. UDP headers) rather than the encapsulating protocol (e.g. TCP headers). Similarly, in some embodiments in which packets are encapsulated and encrypted or compressed, the flow distributor may calculate the hash based on the headers of the payload packet after decryption or decompression. In still other embodiments, nodes may have internal IP addresses, such as for configuration or administration purposes. Traffic to these IP addresses need not be hashed and distributed, but rather may be forwarded to the node owning the destination address. For example, an appliance may have a web server or other server running for configuration or administration purposes at an IP address of 1.2.3.4, and, in some embodiments, may register this address with the flow distributor as its internal IP address. In other embodiments, the flow distributor may assign internal IP addresses to each node within the appliance cluster 600. Traffic arriving from external clients or servers, such as a workstation used by an administrator, directed to the internal IP address of the appliance (1.2.3.4) may be forwarded directly, without requiring hashing.

G. Systems and Methods for Sharing Data Link Layer Information of Network Traffic Distributed Across a Cluster

The systems and methods of the present solution illustrated in FIGS. 7A-7B are directed to sharing data link layer information of network traffic distributed across a cluster of intermediary devices, such as the clustered environment depicted in FIG. 6. One or more intermediary devices or nodes of the cluster may operate as flow receiving nodes or flow processing nodes. Flow receiving nodes are nodes that establish a communication with a client, such that the client can send and receive transport packets to and from the flow receiving node. Flow processing nodes are nodes that establish a communication with servers corresponding to transport packets sent by the client to the flow receiving nodes. When a client sends a transport request packet to the cluster 600, the cluster selects one of the appliances to act as a flow receiving node. The flow

receiving node receives the request packet and identifies the data link layer information corresponding to the client and a destination server to which the client is sending a request. The flow receiving node modifies the transport request packet to include the identified data link layer information corresponding to the request packet sent by the client. The flow receiving node forwards the modified transport request packet to a flow processing node that is selected to process the transport request packet. The flow processing node receives the modified transport request packet and identifies the data link layer information corresponding to the request packet sent by the client. The flow processing node caches the identified data link layer information. The flow processing node forwards the transport request packet to the server identified in the cached data link layer information. The server sends back a response packet to the flow processing node as the request packet received by the server contained data link layer information corresponding to the flow processing node.

Upon receiving the response packet from the server, the flow processing node identifies the server from where the response packet was transmitted. The flow processing node matches the response packet to the request packet previously transmitted by the flow processing node. Upon identifying the request packet, the flow processing node is able to identify the flow receiving node that forwarded the request packet to the flow processing node. The flow processing node modifies the response packet to include the cached data link layer information corresponding to the request packet sent by the client, and forwards the modified response packet to the flow receiving node. The flow receiving node identifies the data link layer information corresponding to the client and forwards the response packet to the client that initially sent the request packet.

Referring now to FIG. 7A, an embodiment of a system of sharing data link layer information in a clustered environment is depicted. In brief overview, a plurality of nodes, may establish a cluster 600. Each node in the cluster may be an appliance 200A-200N (e.g., intermediary device) which can be in communication with one or more clients, such as client 102 via a network 104 and a client data plane 602, or can be in communication with one or more servers, such as server 106, via a network 104' and a server data plane 604. Each appliance in the cluster may be in communication with other appliances in the cluster via a backplane 606. Each appliance may operate one or more packet processing engines 548A-548N, generally referred to as PPE or packet engine 548. Each packet engine may comprise a packet modifier 702A-702N (generally referred to as packet modifier 702) to perform the data link layer information sharing techniques and operations described herein and update a cache 704A-704N generally referred to as cache 704) according to such techniques and operations. Any or all of the appliances 200A-200N of the cluster, such as via configuration of the PPE, may be MAC Based Forwarding (MBF) 722A-722N enabled.

The cluster 600 may comprise any embodiments of the cluster described in connection with FIG. 6. The cluster may include any number of nodes of intermediary devices, such as appliances 200, deployed between a plurality of clients and a plurality of servers, such as a datacenter. Each of the intermediary devices may comprise any embodiments of the appliance 200 described herein. Generally, an intermediary device or appliance of the cluster may also be referred to as node of the cluster. In some embodiments, an intermediary device of the cluster is a single processor appliance. In some embodiments, an intermediary device of the cluster is a multi-processor or multi-core appliance. In some embodiments, each appliance of the cluster is the same type of appliance. In

some embodiments, one or more appliances of the cluster is of a different type than one or more other appliances of the cluster.

Each node or intermediary device of the cluster may execute or operate one or more packet processing engines (PPE) 548, which may include any embodiments of the packet engine described herein. In some embodiments, the packet processing engine 548 comprises any embodiments of the packet engine described in connection with FIGS. 2A and 2B. In some embodiments, the packet processing engine comprises any embodiments of the virtualized packet processing engine described in connection with FIGS. 4A-4C. In some embodiments, the packet processing engine comprises any embodiments of the packet processing engine described in connection with FIGS. 5A-5B.

One or more nodes or intermediary devices of the cluster may be in communication via a network 104 with a client data plane 602. In some embodiments, the client data plane 602 comprises any embodiments of the client data plane described in connection with FIG. 6. Similarly, one or more nodes or intermediary devices of the cluster may be in communication via a network 104' with a server data plane 604. In some embodiments, the server data plane 604 comprises any embodiments of the server data plane described in connection with FIG. 6.

One or more nodes of the cluster may be configured to act as a flow receiving node or a flow processing node. In some embodiments, a flow receiving node can also act as a flow processing node, and vice versa. For the sake of convenience and clarity, the functionality of a flow receiving node will be described using appliance 200A, while the functionality of a flow processing node will be described using appliance 200B.

Flow receiving node 200A can receive a transport layer request packet ("request packet") from the client 102. The request packet includes data link layer information, including but not limited to a virtual local access network (VLAN) identifier, an interface identifier, and a media access control (MAC) identifier, that corresponds to the client 102. The request packet may also include destination address information of a server to which the request packet is destined.

The flow receiving node 200A includes the packet engine 548A. The packet engine may include any embodiments of the packet engine described herein, including a multi-core based packet engine or a virtualized packet engine.

The packet engine may implement, include, communicate with or use a packet modifier 702A to perform any of the packet modification functionality and operations described herein. In some embodiments, the packet engine is designed and constructed with a packet modifier 702A. In some embodiments, the packet modifier is a separate program, process, thread, service or task. In some embodiments, the packet modifier is designed and constructed to perform any of the packet processing and modification functionality and operations described herein, such as in connection with FIG. 7B.

The packet modifier may be designed and constructed to identify a predetermined set of data link layer or layer 2 information (generally referred to as layer 2 information), such as a MAC id, interface and/or VLAN identifier. The packet modifier may be designed and constructed to obtain the value of the predetermined set of layer 2 information and use these values for modifying a packet. The packet modifier may be designed and constructed to store or hold these values in memory or storage, such via a cache. The packet modifier may be designed and constructed to copy, embed, insert or modify, or otherwise what may be referred to as piggybacking by those skilled in the art, a packet to include the layer 2

information or values other than at the layer 2 portion of the packet, such as between layer 2 and layer 3 or in any layer above layer 2. The packet modifier may be designed and constructed to fit or embed the layer 2 information or values into a predetermined format or a fixed format, such as a header or field above layer 2 within a predetermined length. The packet modifier may be designed and constructed to compress the layer 2 information or values into a length shorter than the length of such information or values.

The packet modifier may be designed and constructed to identify to the receiver of the modified packet that such packet includes embedded or piggybacked layer 2 information. The packet modifier may be designed and constructed to identify the modification or piggybacking by any type of flag in any header or field of the packet. The packet modifier may be designed and constructed to identify the modification or piggybacking by a predetermined MAC id which may have a predetermined format and which may identify a cluster via a cluster identifier and a node of the cluster via a node identifier. The cluster identifier and node identifier may be embedded within a portion of the MAC id which identifies the source MAC Id of the sender of the modified packet.

The packet engine and/or packet modifier may be designed and constructed to store the layer 2 information in association with or identified by any tuple information of any transport layer connection, such as a transport layer connection with the client, the server or between the client and the server. In some embodiments, the flow receiver stores the layer 2 information in connection with, identified by or indexed by tuple information of the connection with the client. In some embodiments, the flow processor stores the layer 2 information in connection with, identified by or indexed by tuple information of the connection with the server.

In operation, the packet modifier 702A can identify the data link layer information included in the request packet. In some embodiments, the packet modifier 702A identifies the VLAN identifier, the interface identifier, and the MAC identifier of the client as well as the data link layer information corresponding to the destination server 106. In some embodiments, the flow receiving node 200A can store the data link layer information corresponding to the client 102 and the server 106 in the cache 704A.

The packet modifier can modify the received request packet and send the modified request packet to the flow processing node 200B. The packet modifier modifies the request packet by including the identified data link layer information in the request packet. In some embodiments, one or more of the VLAN identifier, the interface identifier, and the MAC identifier corresponding to the client 102 are included in the modified request packet. The packet modifier can modify the request packet by including the data link layer information corresponding to the client 102 in a payload of the request packet. In some embodiments, the request packet is modified by embedding the data link layer information in at least one of a field of a data link layer, a field of a network layer, or a field of a transport layer of the modified request packet. In some embodiments, any other identifier not related to the data link layer information of the client may be used instead, such as an address of the cache location where the data link layer information corresponding to the client 102 or the server 104 is stored.

The packet modifier 702A can further modify the source data link layer information of the request packet to include data link layer information of the flow receiving node 200A. In some embodiments, the packet modifier includes the MAC identifier of the flow receiving node as the source MAC id of the modified request packet. The MAC identifier of the flow

receiving node can include a cluster identifier identifying the cluster and a node identifier identifying the flow receiving node.

Once the packet modifier 702A modifies the request packet, the flow receiving node 200A transmits the modified request packet to one or more of the other appliances 200B-N. In some embodiments, the flow receiving node 200A transmits the modified request packet to each of the other appliances 200B-N on the common data backplane 606. In some embodiments, the flow receiving node 200A can steer the modified request packet to an appropriate flow processing node 200B via the backplane. For example, Upon receipt of network traffic, a cluster node, such as an intermediary computing device or appliance, may internally steer a portion of the traffic via an inter-node communications backplane to one or more other nodes in the cluster so that the load is equally handled by all of the nodes in the cluster. A cluster node may determine whether to process the traffic steered via the backplane by computing a hash of packet parameters of the network traffic. Hash keys may be selected such that uniformity is assured, and the key used in hash computation may be synchronized across all of the nodes so that only one node determines that it should process the particular packets or traffic flow. In one embodiment, given a hash value, a permutation of nodes is derived and the first active node in this permutation is selected as the flow processor for the traffic. This may reduce traffic steering errors or the need to calculate new hash keys and tables should a node join or leave the cluster and may result in detectable failure of at worst, no more than 1/N connections, and with connection mirroring, failure of no connections.

In some embodiments, the flow receiving node 200A can use tunneling to transmit the modified request packet to an appropriate flow processing node 200B. In some embodiments, the flow receiving node 200A can transmit the modified request packet to the appropriate flow processing node 200B using linksets. A linkset (LS) refers to a set of links of a cluster connected to the same Ethernet segment (broadcast domain). In an asymmetric network, the linkset may have as members the interfaces from the nodes of the cluster that have a presence on the same Ethernet segment. Members of the same linkset may communicate using these interface derived or identified from the linkset information. By using linksets, packet steering may be avoided. When a flow processor receives tunneled information from the flow receiver, the equivalent link on the flow processor is derived from the linkset and if the flow processor has a local link, which is used for sending the response back rather than steering to the flow receiver.

The flow receiving node 200A may wait to receive a response to the modified request packet. Upon receiving a response to the modified request packet, the flow receiving node 200A forwards the response packet to the client 102. Additional details regarding this exchange is provided below after a discussion on the flow processing node 200B.

Once the flow receiving node 200A transmits the modified request packet to the other appliances 200B-N, one of the appliances 200B-N is selected to act as a flow processing node for that particular request packet.

The flow processing node 200B can receive the modified request packet from the flow receiving node 200A via the backplane 600. In some embodiments, the flow processing node can receive the modified request packet via a dedicated link established between the flow receiving node 200A and the flow processing node 200B. Regardless of the manner in which the flow processing node 200B receives the modified request packet, the request packet includes data link layer

information corresponding to the client **102** and the server **106**. Upon receiving the modified request packet, the packet modifier **702B** processes the modified request packet. To process the modified request packet, the packet modifier **702** identifies the data link layer information corresponding to the client **102** within the modified request packet. As described above, the data link layer information corresponding to the client can include one or more of the VLAN identifier, the interface identifier, and the MAC identifier corresponding to the client **102**. The data link layer information may be located in at least one of the payload of the request packet, a field of a data link layer, a field of a network layer, or a field of a transport layer of the modified request packet. Upon identifying this data link layer information, the packet modifier **702B** stores the identified data link layer information in the cache **704B**. In embodiments where an address of the cache location in the cache **704A** of the data receiving node **200A** is provided, the packet modifier **702B** identifies the address of the cache location and stores the cache location address instead of the data link layer information of the client **102**. In addition, the packet modifier **702B** can store the data link layer information corresponding to the modified request packet. In some embodiments, the packet modifier **702B** can include the data link layer information corresponding to the flow receiving node **200A**, such as the MAC id of the flow receiving node **200A**, which is provided as the source MAC id of the modified request packet. In some embodiments, the packet modifier **702B** can also include the data link layer information corresponding to the server to which the request packet was originally destined.

The packet modifier **702B** removes the data link layer information corresponding to the client **102** that is included in the modified request packet. In addition, the packet modifier **702B** modifies the data link layer information of the modified request packet to include the data link layer information of the flow processing node. The flow processing node **200B** then transmits this further modified request packet to the server **106**. In some embodiments, the flow processing node **200B** transmits the further modified request packet to the server via the server data plane **606** over the network **104**.

The flow processing node **200B** may receive a response packet from the server **106** in response to the request packet sent to the server **106**. The flow processing node **200B** receives the response packet from the server since the server **106** utilizes the data link layer information in the further modified request packet to identify the entity to which the response is to be sent. Upon receiving the response packet from the server, the flow processing node **200B** identifies the data link layer information of the response packet to identify the server from where the response packet was sent. Upon identifying the link layer information of the server, the flow processing node performs a lookup in the cache **704B** to identify the flow receiving node **200A** corresponding to the data link layer information of the server **106**. In addition, the flow processing node **200B** can perform a lookup in the cache **704B** to identify the data link layer information of the client corresponding to the flow receiving node **200A**.

The packet modifier **702B** modifies the response packet to include the data link layer information of the client **102**. In embodiments where the flow receiving node **200A** provided a cache location address of the cache **704A**, the packet modifier **702B** can include the same cache location address instead of the client's data link layer information. In some embodiments, the packet modifier **702B** includes the data link layer information corresponding to the client **102** in at least one of the payload of the request packet, a field of a data link layer, a field of a network layer, or a field of a transport layer of the

modified response packet. In some embodiments, the packet modifier **702B** can modify the data link layer information of the response packet to include the MAC id of the data receiving node **200A** as the destination MAC id. In some embodiments, the packet modifier **702B** can modify the data link layer information of the response packet to include at least one of the MAC id of the client **102** as the destination MAC id and the MAC id of the flow receiving node **200A** as the source MAC id.

Once the response packet is modified, the flow processing node **200B** transmits the modified response packet to the data receiving node **200A**. In some embodiments, the flow processing node **200B** steers the modified response packet to the data receiving node **200A** over the backplane **606**. In some embodiments, the flow processing node **200B** can use tunneling to transmit the modified response packet to the flow receiving node **200A**. In other embodiments, the flow processing node **200B** can send the modified response packet to the data receiving node **200A** using the same or equivalent link on which the flow processing node **200B** received the modified request packet from the flow receiving node **200A**. In this way, provided that the flow processing node **200B** modified the response packet to include the MAC id of the client **102** as the destination MAC id and the MAC id of the flow receiving node **200A** as the source MAC id, the flow receiving node **200A** can receive the modified response packet and forward the modified response packet to the client **102** without additional modification.

The cache **704** (generally referred to as cache **704**) can be any type and form of memory or storage element, such as any memory or storage element described herein. In some embodiments, the appliances **200** can have a predetermined amount of memory. The cache **704** can comprise an amount of the memory allocated to each appliances **200**. This memory amount can be measured in bytes, or can be measured as a percentage of the memory allocated to each appliances **200**. Thus, the cache **704** can comprise 1 GB of memory from the memory associated with each appliances **200**, or can comprise 20 percent or one-half of the memory associated with each appliances **200**. In some embodiments, the cache **704** can comprise memory not allocated to the appliances **200**.

The cache may include a cache manager for managing the functions and operations of the cache, such as cache insertion, cache updating and cache retrieval. The cache and cache manager may be designed and constructed to efficiently store and retrieve layer 2 information as described herein. The cache manager may be designed and constructed to use as a cache index as hash of any portions of the layer information. The cache manager may be designed and constructed to store the layer 2 information in association with or identified by any tuple information of any transport layer connection, such as a transport layer connection with the client, the server or between the client and the server.

Each appliance **200** can use the cache **704** to store data link layer information corresponding to transport packets being sent from the client **102** to the server **104** and vice versa. As described above, the flow processing node **200B** can store data link layer information corresponding to the client **102** that sent the request packet in the cache **704B**. In addition, the flow processing node **200B** can also store data link layer information corresponding to the data receiving node **200A** that sent the modified request packet as well as data link layer information corresponding to the server **106** that the modified request packet was sent to and the response packet was received from. In some embodiments, some or all of the data link layer information corresponding to a request packet and a response packet responsive to the request packet can be

61

stored in the cache 704B. It should be appreciated that the flow receiving node 200A can store some or all of the data link layer information corresponding to a request packet and a response packet responsive to the request packet.

In some embodiments, the appliance(s), such as via packet processing engine(s), virtual server(s) and/or packet modifiers, are designed and constructed to support, implement and/or provide MAC based forwarding 722A-722N (generally referred to as MBF 722). With MAC-based forwarding (MBF) enabled on an appliance, when a request reaches the appliance, the appliance remembers the source MAC address of the packet and uses the source MAC as the destination MAC address for the resulting replies. MAC-based forwarding can be used to avoid multiple-route/ARP lookups and to avoid asymmetric packet flows. MAC-based forwarding may be used when the appliance is connected to multiple stateful devices, such as VPNs or firewalls, because it ensures that the return traffic is sent to the same device that the initial traffic came from. MAC-based forwarding may be useful when you use VPN devices, because MAC-based forwarding will ensure that all traffic flowing through a VPN passes back through the same VPN device.

In operation, with MAC-based forwarding (MBF) enabled, the appliance caches the MAC address of the source (a transmitting device such as router, firewall, or VPN device) of the inbound connection and the server that responds to the requests. When a server replies through the appliance, the appliance sets the destination MAC address of the response packet to the cached address, ensuring that the traffic flows in a symmetric manner, and then forwards the response to the client. The process bypasses the route table lookup and ARP lookup function. However, in some embodiments, when the appliance initiates a connection, the appliance uses the route and ARP tables for the lookup function. In embodiments of a direct server return configuration, the MAC-based forwarding is enabled on the appliance(s).

Referring now to FIG. 7B, an embodiment of a method for sharing data link layer information of network traffic distributed across a cluster of intermediary devices is depicted. In brief overview, at step 750, a request packet is received from a client at a flow receiving node 200A. At step 755, the flow receiving node 200A identifies the data link layer information of the request packet. At step 760, the flow receiving node 200A modifies the request packet. At step 765, the flow receiving node 200A transmits the modified request packet to a flow processing node 200B. At step 770, the flow processing node 200B processes the modified request packet. At step 775, the flow processing node 200B modifies the response packet. At step 780, the flow receiving node 200A transmits the modified response packet to the client 102.

At step 750, a request packet is received from a client 102 at a flow receiving node 200A. The request packet may comprise a request to establish a transport layer connection with a server. The request may comprise an application layer request or transaction via an established transport layer connection between the client and the server. Flow receiving node 200A can receive request packet from the client 102 via a client data plane 602, via a network 104. The request packet received by the flow receiving node 200A includes data link layer information, including but not limited to a VLAN identifier, an interface identifier, and a MAC identifier, that corresponds to the client 102. In addition, the request packet also includes destination address information of a server 106 to where the request packet is destined. In some embodiments, the receiving node, appliance or flow receiver is MBF enabled 722.

At step 755, the flow receiving node 200A identifies the data link layer information included in the request packet. In

62

some embodiments, the packet modifier 702A identifies the VLAN identifier, the interface identifier, and the MAC identifier of the client as well as the data link layer information corresponding to the destination server 106. In embodiments of MBF, the flow receiving node may cache the MAC address of the source and/or the server's MAC address.

At step 760, the flow receiving node 200A modifies the request packet. The packet modifier 702A can modify the request packet by including the identified data link layer information in the request packet. In some embodiments, the packet modifier modifies the request packet by including the VLAN identifier and the MAC identifier corresponding to the client 102 in the modified request packet. The packet modifier 200A can include the data link layer information in a payload of the request packet or can embed the data link layer information in at least one of a field of a data link layer, a field of a network layer, or a field of a transport layer of the modified request packet.

The packet modifier can also modify the request packet by modifying the source data link layer information of the request packet to include data link layer information of the flow receiving node 200A. In some embodiments, the packet modifier includes the MAC identifier of the flow receiving node as the source MAC id of the modified request packet. The MAC identifier of the flow receiving node can include the cluster identifier identifying the cluster and the node identifier identifying the flow receiving node.

At step 765, the flow receiving node 200A transmits the modified request packet to a flow processing node 200B. In some embodiments, the flow receiving node 200A can transmit the modified request packet to each of the other appliances 200B-N on the common data backplane 606. In some embodiments, the flow receiving node 200A can steer the modified request packet to an appropriate flow processing node 200B via the backplane. In some embodiments, the flow receiving node 200A can transmit the modified request packet to an appropriate flow processing node 200B using linksets.

At step 770, the flow processing node 200B processes the modified request packet. The step of processing the modified request packet includes receiving the request packet, further modifying the modified request packet, and transmitting the further modified request packet to the server. The flow processing node such as via a packet engine and/or virtual server may perform any of the functionality of an application delivery controller, such as acceleration, application firewall, SSL VPN, load balancing and traffic management.

The flow processing node 200B can receive the modified request packet from the backplane 606 or through a dedicated link established with the flow receiving node 200A. Regardless of the manner in which the flow processing node 200B receives the modified request packet, the request packet includes data link layer information corresponding to the client 102 and/or the server 106.

Upon receiving the modified request packet, the packet modifier 702B processes the modified request packet. To process the modified request packet, the packet modifier 702B identifies the data link layer information corresponding to the client 102 within the modified request packet. As described above, the data link layer information corresponding to the client can include one or more of the VLAN identifier, the interface identifier, and the MAC identifier corresponding to the client 102. The data link layer information may be included in at least one of the payload of the request packet, a field of a data link layer, a field of a network layer, or a field of a transport layer of the modified request packet.

Upon identifying this data link layer information, the packet modifier 702B stores the identified data link layer

63

information in the cache 704B. In addition, the packet modifier 702B can store in the cache 704B, the data link layer information corresponding to the modified request packet, such as the data link layer information, including the MAC id of the flow receiving node 200A, which is provided as the source MAC id of the modified request packet. In some embodiments, the packet modifier 702B can also store in the cache 704B, the data link layer information corresponding to the server to which the request packet was originally destined.

The packet modifier 702B removes the data link layer information corresponding to the client 102 that is included in the modified request packet. The packet modifier 702B modifies the data link layer information of the modified request packet to include the data link layer information of the flow processing node 200B. The flow processing node 200B transmits this further modified request packet to the server 106.

At step 775, the flow processing node 200B modifies the response packet. The step of modifying the response packet includes receiving the response packet from the server 106, identifying the data link layer information of the response packet, modifying the response packet to include the data link layer information of the client 102, and transmitting the modified response packet to the flow receiving node 106.

The flow processing node 200B receives the response packet from the server 106 in response to the request packet sent to the server 106. Upon receiving the response packet from the server, the flow processing node 200B identifies the data link layer information of the response packet to identify the server from where the response packet was sent. Upon identifying the link layer information of the server 106, the flow processing node 200B performs a lookup in the cache 704B to identify the flow receiving node 200A corresponding to the data link layer information of the server 106. In addition, the flow processing node 200B can perform a lookup in the cache 704B to identify the data link layer information of the client corresponding to the flow receiving node 200A. In embodiments of MBF, the appliance may use the cached MAC information as the destination MAC of the response packet to the client.

The packet modifier 702B modifies the response packet to include the data link layer information of the client 102. In some embodiments, the packet modifier 702B includes the data link layer information corresponding to the client 102 in at least one of the payload of the request packet, a field of a data link layer, a field of a network layer, or a field of a transport layer of the modified response packet. In some embodiments, the packet modifier 702B can modify the data link layer information of the response packet to include the MAC id of the data receiving node 200A as the destination MAC id. In some embodiments, such as for MBF, the packet modifier 702B can modify the data link layer information of the response packet to include at least one of the MAC id of the client 102 as the destination MAC id and the MAC id of the flow receiving node 200A as the source MAC id.

Once the response packet is modified, the flow processing node 200B transmits the modified response packet to the data receiving node 200A. In some embodiments, the flow processing node 200B steers the modified response packet to the data receiving node 200A over the backplane 606. In such embodiments, the data link layer information of the modified response packet includes the flow receiver MAC id as the destination id. The data link layer information corresponding to the client 102 can be included in the same modified response packet or may be sent to the flow receiving node 200A as a separate packet. In some embodiments, where the flow receiving node 200A also stores data link layer information corresponding to the client in an associated cache 704A,

64

the flow receiving node may not need to receive the data link layer information corresponding to the client from the flow processing node 200B. In other embodiments, the flow processing node 200B can send the modified response packet to the data receiving node 200A using the same or equivalent dedicated link on which the flow processing node 200B received the modified request packet from the flow receiving node 200A.

At step 780, the flow receiving node 200A transmits the modified response packet to the client 102. In some embodiments, the flow receiving node 200A receives the modified response packet from the flow processing node 200B. The flow receiving node can identify the data link layer information corresponding to the client, which is included in the modified response packet. The flow receiving node 200A then modifies the data link layer information of the modified response packet to include the data link layer information corresponding to the client. In some embodiments, the flow receiving node 200A modifies the data link layer information of the modified response packet to include the MAC id of the flow receiving node 200A and the destination address corresponding to the client's data link layer information. In this way, when the client receives the further modified response packet, the client recognizes the data link layer information of the flow receiving node being the same as the data link layer information of the entity that received the original request packet.

It should be understood that the systems described above may provide multiple ones of any or each of those components and these components may be provided on either a standalone machine or, in some embodiments, on multiple machines in a distributed system. The systems and methods described above may be implemented as a method, apparatus or article of manufacture using programming and/or engineering techniques to produce software, firmware, hardware, or any combination thereof. In addition, the systems and methods described above may be provided as one or more computer-readable programs embodied on or in one or more articles of manufacture. The term "article of manufacture" as used herein is intended to encompass code or logic accessible from and embedded in one or more computer-readable devices, firmware, programmable logic, memory devices (e.g., EEPROMs, ROMs, PROMs, RAMs, SRAMs, etc.), hardware (e.g., integrated circuit chip, Field Programmable Gate Array (FPGA), Application Specific Integrated Circuit (ASIC), etc.), electronic devices, a computer readable non-volatile storage unit (e.g., CD-ROM, floppy disk, hard disk drive, etc.). The article of manufacture may be accessible from a file server providing access to the computer-readable programs via a network transmission line, wireless transmission media, signals propagating through space, radio waves, infrared signals, etc. The article of manufacture may be a flash memory card or a magnetic tape. The article of manufacture includes hardware logic as well as software or programmable code embedded in a computer readable medium that is executed by a processor. In general, the computer-readable programs may be implemented in any programming language, such as LISP, PERL, C, C++, C#, PROLOG, or in any byte code language such as JAVA. The software programs may be stored on or in one or more articles of manufacture as object code.

While various embodiments of the methods and systems have been described, these embodiments are exemplary and in no way limit the scope of the described methods or systems. Those having skill in the relevant art can effect changes to form and details of the described methods and systems without departing from the broadest scope of the described meth-

65

ods and systems. Thus, the scope of the methods and systems described herein should not be limited by any of the exemplary embodiments and should be defined in accordance with the accompanying claims and their equivalents.

The invention claimed is:

1. A method for sharing data link layer information of network traffic distributed across a cluster of intermediary devices, the method comprising:

- (a) receiving, by a first intermediary device of a cluster comprising a plurality of intermediary devices, a transport layer packet;
- (b) identifying, by the first intermediary device, a first set of data link layer information from a data link layer of the transport layer packet;
- (c) modifying, by the first intermediary device, the transport layer packet for transmission on a common data backplane of the cluster to include the first set of data link layer information in the transport layer packet and to replace, at the data link layer, the first set of data link layer information with a second set of data link layer information different from the first set of data link layer information, the second set of data link layer information identifying, as a source Media Access Control (MAC) id, a Media Access Control (MAC) id comprising a cluster identifier identifying the cluster and a node identifier identifying the first intermediary device; and
- (d) transmitting, by the first intermediary device, the modified transport layer packet on the common data backplane of the cluster to each of the other intermediary devices of the cluster.

2. The method of claim 1, wherein step (a) further comprising receiving, by the first intermediary device, the transport layer packet from a client that initiated a transport layer connection to the cluster.

3. The method of claim 1, wherein step (b) further comprises identifying, by the first intermediary device, the first set of data link layer information comprising a combination of two or more of the following: interface identifier, virtual local area network (VLAN) identifier and Media Access Control (MAC) identifier.

4. The method of claim 1, wherein step (c) further comprises modifying, by the first intermediary device, the transport layer packet to include the first set of data link layer information in one of the following: a payload of the transport layer packet, embedded in a field of the data link layer of the transport layer packet, and embedded in a field of a network layer of the transport layer packet, and embedded in a field of a transport layer of the transport layer packet.

5. The method of claim 1, wherein step (d) further comprises transmitting, by the first intermediary device, the modified transport layer packet with a Media Access Control (MAC) id set at the data link layer comprising a cluster identifier identifying the cluster and a node identifier identifying the first intermediary device.

6. The method of claim 1, further comprising determining, by a second intermediary device of the cluster, to process the network packet responsive to identifying that the data link layer of the modified transport layer packet has a Media Access Control (MAC) id comprising a cluster identifier identifying the cluster and a node identifier identifying the first intermediary device.

7. The method of claim 6, further comprising identifying, by the second intermediary device responsive to the determination, the first set of data link layer information from the transport layer packet.

66

8. The method of claim 7, further comprising caching, by the second intermediary device, the first set of data link layer information.

9. The method of claim 8, further comprising using, by the second intermediary device, the cached first set of data link layer information for the data link layer of a second transport layer packet to be transmitted as a response to a request of the transport layer packet.

10. A method for Media Access Control (MAC) based forwarding in a cluster of intermediary devices, the method comprising:

- (a) identifying, by a first intermediary device of a cluster comprising a plurality of intermediary devices, a first Media Access Control (MAC) id at a data link layer of a transport layer packet of a request received by the first intermediary device;
- (b) transmitting, by the first intermediary device, the transport layer packet on a common data backplane of the cluster to each of the other intermediary devices of the cluster, the transport layer packet modified to include the first MAC id and replace, at the data link layer, the first MAC id with a second MAC id, different than the first MAC id, at the data link layer of the transport layer packet, the second MAC id comprising a cluster identifier identifying the cluster and a node identifier identifying the first intermediary device;
- (c) removing, by a second intermediary device, the first MAC id from the transport layer packet received by the second intermediary device via the common data backplane of the cluster;
- (d) caching, by the second intermediary device, the MAC id to a cache of the second intermediary device;
- (e) retrieving, by the second intermediary device responsive to receipt of a response to the request, the first MAC id from the cache; and
- (f) forwarding, by the second intermediary device, the response modified to set the first MAC id retrieved from the cache as the MAC id at the data link layer of one or more transport layer packets of the response.

11. The method of claim 10, wherein step (a) further comprises enabling MAC based forwarding on each intermediary device of the cluster.

12. The method of claim 10, wherein step (a) further comprises identifying, by the first intermediary device, from the data link layer of the transport layer request data link layer information comprising two or more of the following: MAC id, interface and source virtual local area network (VLAN) identifier.

13. The method of claim 12, wherein step (b) further comprises modifying, by the first intermediary device, the transport layer packet to include the data link layer information in one of the following: a payload of the transport layer packet, embedded in a field of the data link layer, embedded in a field of a network layer, and embedded in a field of a transport layer.

14. The method of claim 12, wherein step (c) further comprises removing, by the second intermediary device, the data link layer information from the transport layer packet received by the second intermediary device via the common data backplane of the cluster.

15. The method of claim 12, wherein step (d) further comprises caching, by the second intermediary device, the data link layer information, to the cache.

16. The method of claim 12, wherein step (e) further comprises retrieving, by the second intermediary device responsive to receipt of the response to the request, the data link layer information from the cache.

17. The method of claim 12, wherein step (f) further comprises forwarding, by the second intermediary device, the response modified to use the data link layer information retrieved from the cache for corresponding fields of the data link layer of one or more transport layer packets of the response. 5

18. The method of claim 12, wherein step (f) further comprises tunneling, by the second intermediary device, the response to the first intermediary device.

19. The method of claim 18, further comprising forward- 10
ing, by the first intermediary device, the response to a destination identified by the MAC id.

* * * * *