



(86) Date de dépôt PCT/PCT Filing Date: 2009/05/18
 (87) Date publication PCT/PCT Publication Date: 2009/11/26
 (85) Entrée phase nationale/National Entry: 2010/04/08
 (86) N° demande PCT/PCT Application No.: US 2009/044331
 (87) N° publication PCT/PCT Publication No.: 2009/143052
 (30) Priorité/Priority: 2008/05/19 (US12/123,341)

(51) Cl.Int./Int.Cl. *A63B 53/04* (2006.01)
 (71) Demandeur/Applicant:
 NIKE INTERNATIONAL, LTD., US
 (72) Inventeurs/Inventors:
 FRANKLIN, DAVID N., US;
 STITES, JOHN T., US
 (74) Agent: SMART & BIGGAR

(54) Titre : TETES DE PUTTER ET PUTTERS COMPRENANT UN MATERIAU POLYMERE EN TANT QUE PARTIE DE LA FACE FRAPPANT LA BALLE
 (54) Title: PUTTER HEADS AND PUTTERS INCLUDING POLYMERIC MATERIAL AS PART OF THE BALL STRIKING FACE

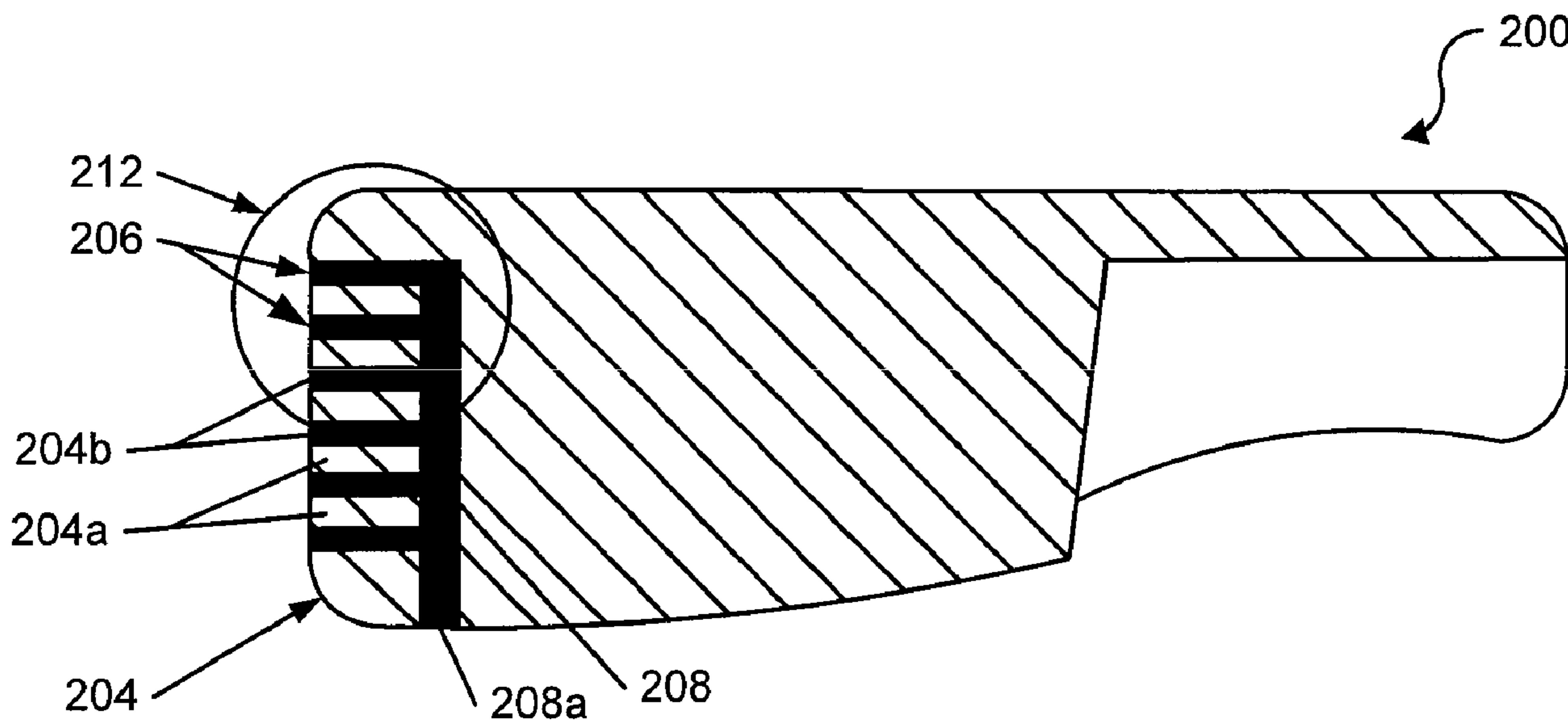

FIG. 2A

(57) **Abrégé/Abstract:**

Putters include a putter body (200) having a ball striking face member (204) made of a material having a first hardness characteristic. A cavity (208) is defined in the putter body behind the ball striking face member, and plural openings (206) are defined in the ball striking face member extending rearward with respect to the ball striking face member and into the cavity. A polymeric material (204b) at least partially fills the openings and the cavity, wherein the polymeric material has a second hardness characteristic that is softer than the first hardness characteristic. The ball striking face member and the polymeric material exposed in at least some of the openings provide a ball striking surface of the putter. The ball striking surface may include grooves or

(57) **Abrégé(suite)/Abstract(continued):**

scorelines to affect the launch angle, spin, and/or roll of the ball during a putt. Methods for making such putter devices also are described.

(12) INTERNATIONAL APPLICATION PUBLISHED UNDER THE PATENT COOPERATION TREATY (PCT)

(19) World Intellectual Property Organization
International Bureau(43) International Publication Date
26 November 2009 (26.11.2009)(10) International Publication Number
WO 2009/143052 A1(51) International Patent Classification:
A63B 53/04 (2006.01)(74) Agent: RAUCHHOLZ, William, F.; Banner & Witcoff,
Ltd., 1100 13th Street, Nw, Suite 1200, Washington, DC
20005 (US).(21) International Application Number:
PCT/US2009/044331(81) Designated States (unless otherwise indicated, for every
kind of national protection available): AE, AG, AL, AM,
AO, AT, AU, AZ, BA, BB, BG, BH, BR, BW, BY, BZ,
CA, CH, CN, CO, CR, CU, CZ, DE, DK, DM, DO, DZ,
EC, EE, EG, ES, FI, GB, GD, GE, GH, GM, GT, HN,
HR, HU, ID, IL, IN, IS, JP, KE, KG, KM, KN, KP, KR,
KZ, LA, LC, LK, LR, LS, LT, LU, LY, MA, MD, ME,
MG, MK, MN, MW, MX, MY, MZ, NA, NG, NI, NO,
NZ, OM, PG, PH, PL, PT, RO, RS, RU, SC, SD, SE, SG,
SK, SL, SM, ST, SV, SY, TJ, TM, TN, TR, TT, TZ, UA,
UG, US, UZ, VC, VN, ZA, ZM, ZW.(22) International Filing Date:
18 May 2009 (18.05.2009)

(25) Filing Language: English

(26) Publication Language: English

(30) Priority Data:
12/123,341 19 May 2008 (19.05.2008) US(71) Applicant (for all designated States except JP, KR):
NIKE INTERNATIONAL, LTD. [GB/US]; One Bow-
erman Drive, Beaverton, OR 97005 (US).(71) Applicant (for JP, KR only): **NIKE, INC.** [US/US]; One
Bowerman Drive, Beaverton, OR 97005 (US).

(72) Inventors; and

(75) Inventors/Applicants (for US only): **FRANKLIN,
David, N.** [US/US]; C/o Nike, Inc., One Bowerman
Drive, Beaverton, 97005 (US). **STITES, John, T.**
[US/US]; C/o Nike, Inc., One Bowerman Drive, Beaver-
ton, OR 97005 (US).(84) Designated States (unless otherwise indicated, for every
kind of regional protection available): ARIPO (BW, GH,
GM, KE, LS, MW, MZ, NA, SD, SL, SZ, TZ, UG, ZM,
ZW), Eurasian (AM, AZ, BY, KG, KZ, MD, RU, TJ,
TM), European (AT, BE, BG, CH, CY, CZ, DE, DK, EE,
ES, FI, FR, GB, GR, HR, HU, IE, IS, IT, LT, LU, LV,
MC, MK, MT, NL, NO, PL, PT, RO, SE, SI, SK, TR),
OAPI (BF, BJ, CF, CG, CI, CM, GA, GN, GQ, GW, ML,
MR, NE, SN, TD, TG).

Published:

— with international search report (Art. 21(3))

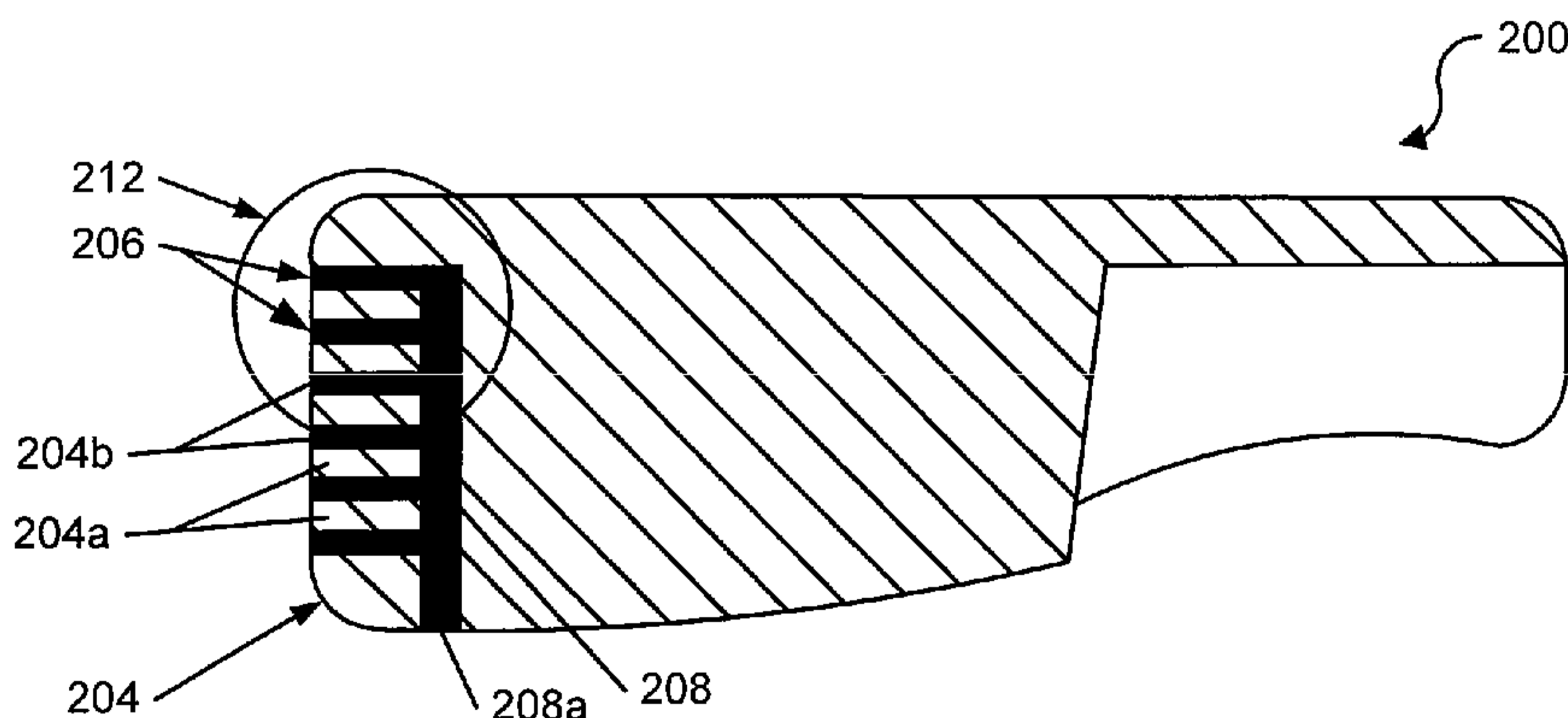
(54) Title: PUTTER HEADS AND PUTTERS INCLUDING POLYMERIC MATERIAL AS PART OF THE BALL STRIKING
FACE**FIG. 2A**(57) Abstract: Putters include a putter body (200) having a ball striking face member (204) made of a material having a first hard-
ness characteristic. A cavity (208) is defined in the putter body behind the ball striking face member, and plural openings (206)
are defined in the ball striking face member extending rearward with respect to the ball striking face member and into the cavity. A
polymeric material (204b) at least partially fills the openings and the cavity, wherein the polymeric material has a second hardness
characteristic that is softer than the first hardness characteristic. The ball striking face member and the polymeric material exposed
in at least some of the openings provide a ball striking surface of the putter. The ball striking surface may include grooves or
scorelines to affect the launch angle, spin, and/or roll of the ball during a putt. Methods for making such putter devices also are
described.

WO 2009/143052 A1

**PUTTER HEADS AND PUTTERS INCLUDING POLYMERIC
MATERIAL AS PART OF THE BALL STRIKING FACE**

FIELD OF THE INVENTION

- [01] The invention relates generally to putter heads and putters. Putter heads and putters in accordance with at least some examples of this invention may be constructed to include a relatively soft polymeric material as at least a portion of the ball striking face.

BACKGROUND

- [02] Golf is enjoyed by a wide variety of players – players of different genders and players of dramatically different ages and skill levels. Golf is somewhat unique in the sporting world in that such diverse collections of players can play together in golf events, even in direct competition with one another (*e.g.*, using handicapped scoring, different tee boxes, in team formats, etc.), and still enjoy the golf outing or competition. These factors, together with increased availability of golf programming on television (*e.g.*, golf tournaments, golf news, golf history, and/or other golf programming) and the rise of well known golf superstars, at least in part, have increased golf's popularity in recent years both in the United States and across the world. The number of individuals participating in the game and the number of golf courses have increased steadily over recent years.
- [03] Golfers at all skill levels seek to improve their performance, lower their golf scores, and reach that next performance “level.” Manufacturers of all types of golf equipment have responded to these demands, and recently, the industry has witnessed dramatic changes and improvements in golf equipment. For example, a wide range of different golf ball models now are available, with some balls designed to complement specific swing speeds and/or other player characteristics or preferences, *e.g.*, with some balls designed to fly farther and/or straighter, some designed to provide higher or flatter trajectories, some designed to provide more spin, control, and/or feel (particularly around the greens), etc. A host of swing aids and/or teaching aids also are available on the market that promise to help lower one's golf scores.

- [04] Being the sole instruments that set golf balls in motion during play, golf clubs also have been the subject of much technological research and advancement in recent years. For example, the market has seen improvements in putter designs, golf club head designs, shafts, and grips in recent years. Additionally, other technological advancements have been made in an effort to better match the various elements and/or characteristics of the golf club and/or characteristics of a golf ball to a particular user's swing features or characteristics (*e.g.*, club fitting technology, ball launch angle measurement technology, ball spin rate characteristics, etc.).
- [05] Golfers tend to be sensitive to the "feel" of a golf club, particularly with respect to putters. The "feel" of a golf club comprises the combination of various component parts of the club and various features associated with the club that produce the sensory sensations experienced by the player when a ball is swung at and/or struck. Club "feel" is a very personal characteristic in that a club that "feels" good to one user may have totally undesirable "feel" characteristics for another. Club weight, weight distribution, aerodynamics, swing speed, and the like all may affect the "feel" of the club as it swings and strikes a ball. "Feel" also has been found to be related to the visual appearance of the club and the sound produced when the club head strikes a ball to send the ball in motion.
- [06] While technological improvements to golf club designs have been made, because of the very personal nature of the putter stroke and the "feel" aspects of putting a golf ball, no single putter structure is best suited for all players. New putter structures that change the look and feel of the club are welcomed by at least some players.

SUMMARY

- [07] The following presents a general summary of aspects of the invention in order to provide a basic understanding of this invention. This summary is not intended as an extensive overview of the invention. It is not intended to identify key or critical elements of the invention or to delineate the scope of the invention. The following summary merely presents some concepts of the invention in a general form as a prelude to the more detailed description provided below.

- [08] Aspects of this invention relate to putters and putter heads that include: (a) a putter body (made from one or multiple independent pieces or parts) including a ball striking face member made of a material having a first hardness characteristic, wherein a cavity is defined in the putter body behind the ball striking face member, and wherein a plurality of independent and separated openings are defined in the ball striking face member, the independent and separated openings extending rearward with respect to the ball striking face member so as to open into the cavity; (b) a polymeric material provided to at least partially fill the plurality of openings and the cavity, wherein the polymeric material has a second hardness characteristic that is softer than the first hardness characteristic, and wherein the ball striking face member and the polymeric material exposed in at least some of the openings provide a ball striking surface of the putter head; (c) a shaft (or other handle) member engaged with the putter body; and/or (d) a grip member engaged with the shaft member (or other handle member). The polymeric material may completely fill the plurality of openings and the cavity.
- [09] The polymeric material generally will lighten the club head structure, and thus allow a club designer to provide weight at other locations in the club head structure (*e.g.*, to increase the club head's moment of inertia characteristics, to control the center of gravity location, etc.). Additionally, the presence of the polymeric material at the ball striking surface (and in contact with the ball during a putt) will influence the ball spin, as well as the sound and "feel" characteristics of the putter (*e.g.*, due to vibration damping effects of the polymeric material).
- [10] If desired, the ball striking surface of putter structures in accordance with at least some examples of this invention may include a plurality of grooves defined therein (also call "scorelines"). The grooves or scorelines can help control and produce desired launch angles and/or spin rates of a golf ball during a putt. The grooves may be defined in the material making up the ball striking face member (*e.g.*, between adjacent openings in the ball striking face member), in the polymeric material, or in both the material making up the ball striking face member and the polymeric material. If desired, a single continuous groove may be partially provided in the polymeric material and partially provided in the ball striking face member material immediately adjacent to the polymeric material.

- [11] Additional aspects of this invention also relate to methods for making putters and putter heads, *e.g.*, of the various types described above.

BRIEF DESCRIPTION OF THE DRAWINGS

- [12] A more complete understanding of the present invention and certain advantages thereof may be acquired by referring to the following detailed description in consideration with the accompanying drawings, in which like reference numbers indicate like features, and wherein:
- [13] Figs. 1A and 1B illustrate an example putter structure in accordance with this invention;
- [14] Figs. 2A through 2D illustrate additional features of a polymer filled putter head in accordance with examples of this invention;
- [15] Figs. 3 and 4 illustrate alternative features of grooves or scorelines that may be included in putter structures in accordance with at least some examples of this invention;
- [16] Figs. 5 through 9 illustrate alternative features of the openings, cavities, and port arrangements that may be included in putter structures in accordance with at least some examples of this invention;
- [17] Figs. 10 through 12B illustrate various examples of the openings and the polymeric material arrangements on the ball striking surface of a putter structure in accordance with this invention;
- [18] Figs. 13 through 15 illustrate various example putter head constructions that may include polymer filled openings on the ball striking face and cavities in accordance with examples of this invention; and
- [19] Fig. 16 provides an illustrative aid for explaining various example methods of making putter heads in accordance with this invention.

DETAILED DESCRIPTION

[20] In the following description of various example putter heads and other aspects of this invention, reference is made to the accompanying drawings, which form a part hereof, and in which are shown by way of illustration various example structures, systems, and steps in which aspects of the invention may be practiced. It is to be understood that other specific arrangements of parts, structures, example devices, systems, and steps may be utilized and structural and functional modifications may be made without departing from the scope of the present invention. Also, while the terms “top,” “bottom,” “front,” “back,” “side,” and the like may be used in this specification to describe various example features and elements of the invention, these terms are used herein as a matter of convenience, *e.g.*, based on the example orientations shown in the figures and/or the orientations during typical use. Nothing in this specification should be construed as requiring a specific three dimensional orientation of structures in order to fall within the scope of this invention.

[21] At least some example aspects of this invention relate to putters and putter heads, as well as to methods of making such structures. A general description of aspects of the invention followed by a more detailed description of specific examples of the invention follows.

A. General Description of Putters, Putter Heads, and Methods According to Aspects of the Invention

[22] In general, aspects of this invention relate to putters and putter heads. Such golf clubs, according to at least some examples of the invention, may include: (a) a putter body (made from one or multiple independent pieces or parts) including a ball striking face member made of a material having a first hardness characteristic, wherein a cavity is defined in the putter body behind the ball striking face member, and wherein a plurality of independent and separated openings are defined in the ball striking face member, the independent and separated openings extending rearward with respect to the ball striking face member so as to open into the cavity; (b) a polymeric material provided to at least partially fill the plurality of openings and the cavity, wherein the polymeric material has a second hardness characteristic that is softer than the first hardness characteristic, and wherein the ball striking face member and the polymeric material exposed in at least some of the openings provide a ball striking surface of the

- putter head; (c) a shaft (or other handle) member engaged with the putter body; and/or (d) a grip member engaged with the shaft member (or other handle member). If desired, the polymeric material may completely fill the plurality of openings and the cavity.
- [23] If desired, the ball striking surface of putter structures in accordance with at least some examples of this invention may include a plurality of grooves defined therein (also call “scorelines”). The grooves may be defined in the material making up the ball striking face member (*e.g.*, between adjacent openings in the ball striking face member), in the polymeric material, or in both the material making up the ball striking face member and the polymeric material. If desired, a single continuous groove may be partially provided in the polymeric material and partially provided in the ball striking face member material immediately adjacent to the polymeric material.
- [24] The plurality of openings in the ball striking face member may be arranged and oriented in a wide variety of ways without departing from this invention. For example, the openings may extend in a parallel or substantially parallel manner across the ball striking surface (*e.g.*, such that the material of the ball striking face member extends between two adjacent openings). The openings may be formed as one or more elongated slots. As additional examples, at least some of the openings may form a design, logo, and/or alphanumeric characters on the ball striking surface. Additionally, any number of openings in any desired arrangement may be provided on the ball striking surface without departing from this invention.
- [25] The openings may be sized and arranged in a variety of different manners without departing from this invention. For example, in some putter head products in accordance with this invention, two adjacent openings may be separated by a distance ranging from 0.03 to 0.5 inches, and in some examples, by a distance of 0.1 to 0.3 inches. This separation distance corresponds to the dimensions of the ball striking face member material between adjacent openings. This separation distance may be constant or it may vary along the length of the openings. Likewise, this separation distance may be constant or it may vary among the adjacent openings present in the ball striking face member. Similarly, the openings themselves may have a variety of dimensions without departing from this invention. For example, the openings may extend all the way across the ball striking surface or partially across the ball striking

- surface (*e.g.*, 10-80% of the way across the ball striking surface, and from 25-75% of the way across the ball striking surface in some examples). The openings may have a height dimension (in the putter head top-to-bottom direction) of any desired value, *e.g.*, ranging from 0.03 to 0.5 inches, and in some example structures from 0.1 to 0.3 inches.
- [26] If desired, the cavity defined in the putter body may extend to and open at a port located at an exterior surface of the putter body (*e.g.*, to allow introduction of the polymeric material in to the cavity and/or in to the openings during manufacture). This cavity access port may be located, for example, at a bottom surface of the putter body, at a top surface of the putter body, and/or at a rear surface of the putter body. More than one cavity access port may be provided in a putter head structure without departing from this invention. If desired, when exposed at the top surface of the putter body, the polymeric material (or a cover member provided in the cavity access port) may form at least a portion of an alignment aid for the putter head. The access port may be shaped to provide additional alignment aid features.
- [27] The openings may extend rearward from the ball striking surface of the putter body (to the cavity) in any desired manner without departing from this invention. For example, at least some of the plurality of independent and separated openings in a putter body may extend rearward from the ball striking surface in a direction substantially perpendicular to the ball striking surface. In other example structures, at least some of the plurality of independent and separated openings may extend rearward from the ball striking surface at a non-perpendicular angle with respect to the ball striking surface, *e.g.*, at an angle of 10° to 80°, and in some examples structures, at any angle within the range of 30° to 60°. The openings also may extend rearward in a curved or other non-linear or irregular manner.
- [28] Additional aspects of this invention relate to methods for making putter devices (such as putters and putter heads of the types described above). Such methods may include, for example: (a) providing a putter body (*e.g.*, by manufacturing it, by obtaining it from a third party source, etc.) including a ball striking face member made of a material having a first hardness characteristic, wherein a cavity is defined in the putter body behind the ball striking face member, and wherein a plurality of independent and separated openings are defined in the ball striking face member, the independent and

separated openings extending rearward with respect to the ball striking face member so as to open into the cavity; (b) placing a polymeric material in the putter body to at least partially fill the plurality of openings and the cavity, wherein the polymeric material has a second hardness characteristic that is softer than the first hardness characteristic, and wherein the polymeric material is inserted such that the ball striking face member and the polymeric material exposed in at least some of the openings provide a ball striking surface of the putter head; (c) attaching a shaft member to the putter body; and/or (d) attaching a grip member to the shaft member. The putter devices may have any of the various characteristics described above.

- [29] Specific examples of the invention are described in more detail below. The reader should understand that these specific examples are set forth merely to illustrate examples of the invention, and they should not be construed as limiting the invention.

B. Specific Examples of the Invention

- [30] The various figures in this application illustrate examples of putters, components thereof, and methods in accordance with examples of this invention. When the same reference number appears in more than one drawing, that reference number is used consistently in this specification and the drawings to refer to the same or similar parts throughout.
- [31] Figs. 1A and 1B illustrate an example putter structure 100 in accordance with this invention. The putter 100 includes a putter head 102 having a ball striking face 104, a top portion 106, a bottom portion 108, and a shaft member 110 engaged with the putter head 102. The top portion 106 of the putter head 102 may include an alignment aid 112 having any desired shape, structure, etc. The putter head 102 may be made from any desired materials without departing from this invention, including, for example, metals, metal alloys, and the like, including materials that are conventionally known and used in the art. Likewise, the shaft member 110 may be made of any desired materials without departing from this invention, including, for example, metals, metal alloys, composites, and the like, including materials that are conventionally known and used in the art.
- [32] As illustrated in Fig. 1A, the ball striking face 104 of the putter head 102 includes at least two different surface features. One portion 104a of the putter head 102 is made

from the base material for the ball striking face, such as the materials described above for the putter head 102 or other conventional materials used for putter ball striking faces. Another portion 104b of the putter head 102 is made from a polymeric material. The polymeric material generally will be softer and more lightweight as compared to the material of the remainder of the ball striking face 104, including portions 104a. As illustrated in Fig. 1A, in this example structure, the two portions 104a and 104b of the ball striking face 104 extend across the ball striking surface of the putter head 102 in an alternating manner, such that a plurality of parallel strips of polymeric material 104b are separated by a plurality of strips of the ball striking face material 104a. Examples of the construction of putter heads to include this alternating material structure will be described in more detail below.

[33] One potential advantage of providing a polymeric material within a putter head relates to the potential for weight savings. By removing some of the metal material from the putter head body, this material may be replaced by a lighter weight polymeric material. This weight savings allows the club designer to place additional weight at other areas of the putter head structure, such as toward the rear corners of the putter head structure. Such features may allow the club designer to control and design a club having higher moment of inertia (resistance to twisting) and desired center of gravity location characteristics. Additionally, by including this relatively soft polymeric material 104b as part of the ball striking face (such that the polymeric material 104b also directly contacts the ball during a putt), the ball strike characteristics of the putter head may be altered and controlled, which affects the sound, rebound, and other “feel” characteristics of the putter head (*e.g.*, by damping vibrations and altering the sound of a ball strike). The polymeric material 104b also may influence ball spin as the ball comes off the putter face.

[34] Figs. 2A through 2D illustrate additional details of a putter head structure 200 in accordance with at least some examples of this invention. Fig. 2A is a cross sectional view taken along a center line of a putter head 200 (between the putter head’s heel and toe direction), *e.g.*, like the putter head 102 illustrated in Figs. 1A and 1B. As shown in Fig. 2A, like Fig. 1A above, the ball striking face 204 of the putter head 200 includes two distinct portions 204a and 204b, namely, a portion 204a made up of the material making the main portion of the ball striking face 204 and a portion 204b

- made from a polymeric material as described above. The polymeric material portion 204b is filled into openings (*e.g.*, slots) 206 defined in the ball striking surface 204 of the putter head 200. The openings 206 may be formed in the ball striking face 204 of the putter head 200 in any desired manner without departing from this invention, including, for example, forming the ball striking face 204 to include such openings 206 (*e.g.*, during the molding, casting, forging, or other production process), machining such openings 206 in a solid block of the putter head material, etc. Any desired number of openings 206 may be provided in a ball striking face 204 without departing from this invention.
- [35] The openings 206 open at their rear ends into an open cavity structure 208 defined in the putter head structure 200. This cavity structure 208 may be formed in the putter head 200 in any desired manner without departing from this invention, including, for example, forming the putter head 200 to include such a cavity 208 (*e.g.*, during the molding, casting, forging, or other production process), machining such a cavity 208 in a solid block of the putter head material, etc. While a single cavity 208 is illustrated in Fig. 2A and all of the openings 206 open in to this single cavity 208, if desired, multiple cavities 208 may be provided in a putter head structure 200, and the openings 206 may open into any one or more of the available cavities without departing from this invention. In this illustrated example structure, the cavity 208 includes an access port member 208a provided in the bottom surface 210 of the putter head structure 200.
- [36] Fig. 2B illustrates an enlarged portion of the putter head structure 200 shown in Fig. 2A (the encircled portion 212 from Fig. 2A). As shown, the ball striking surface 204 includes both the metal (or other) material 204a of the ball striking surface of the putter head 200 and the exposed polymeric material 204b present in the openings 206 defined in the ball striking surface 204. The openings 206 (and thus the height of the exposed polymeric material 204b in the top-to-bottom direction on the ball striking face surface 204) may be made of any desired size without departing from this invention. For example, these openings 206 (and thus the height of the exposed polymeric material 204b) may be in the range of 0.03 to 0.5 inches, and in some examples, from about 0.1 to 0.3 inches. Likewise, the height of the metal (or other) material 204a between adjacent openings 206 (and thus between adjacent portions

- 204b of the polymeric material) may be made of any desired size without departing from this invention. For example, the height of these portions 204a may be in the range of 0.03 to 0.5 inches, and in some examples, from about 0.1 to 0.3 inches. The heights of the portions 204a may be less than, equal to, or greater than the heights of the portions 204b in a given putter head structure. Additionally, the portions 204a and 204b may be of a constant size or of different sizes in a given putter head structure without departing from this invention. The heights of these portions 204a and 204b also may change over the course of the length of the individual portions 204a and 204b (*e.g.*, in a heel-to-toe direction of the putter ball striking face). A wide variety of potential combinations of sizes of the various portions 204a and 204b are possible.
- [37] The cavity 208 may be placed at any desired position and in any desired orientation in the putter head structure 200 without departing from this invention (and thus, the openings 206 may extend in to the putter head structure 200 any desired distance without departing from this invention). For example, at least some portions of the cavity 208 may be oriented from about 0.25 to 2 inches rearward from the ball striking surface, and in some examples, from about 0.25 to 1 inch rearward. Also, while the illustrated cavity 208 is generally parallel to the ball striking face 204, this is not a requirement. Rather, the cavity 208 can have any desired size, shape, orientation, and orientation with respect to the ball striking face 204 without departing from this invention. As some more specific examples, the cavity 208 may extend in a top-to-bottom direction ranging from 50-95% of the overall putter head height at the location of the cavity 208; the cavity 208 may extend rearward by a distance ranging from 0.25 to 6 inches, and in some examples, from 0.5 to 4 inches or even from 0.5 to 3 inches; and the cavity 208 as well as its port 208a may extend in a heel-to-toe direction ranging from 5-95% of the overall putter head heel-to-toe length dimension at the location of the cavity 208 (and in some examples, from 15-85% or even from 25-75% of the overall heel-to-toe dimension at the location of the cavity 208).
- [38] As illustrated in Fig. 2B, the ball striking surface 204 may be smooth (*e.g.*, the portions 204a and 204b may smoothly transfer from one portion to the next in the alternating portion structure). The ball striking surface 204 may be flat, or it may include some roll or bulge characteristics, and/or it may have some desired loft characteristic. This flat and/or smooth surface 204 is not a requirement. To the

contrary, as illustrated in Figs. 2C and 2D, the ball striking surface 204 may include grooves or scorelines 210 formed therein. In these illustrated example structures, the scorelines 210 are formed at an area of the ball striking surface 204 bridging the junctions between the metal portion 204a and the polymeric portion 204b of the ball striking surface 204 such that the scorelines 210 are cut into each of these materials 204a and 204b. The scorelines 210 may be integrally formed in the portions 204a and 204b when the various parts of the ball striking face 204 are formed (*e.g.*, during the molding, casting, forging, or other forming process), and/or they may be formed at a later time (*e.g.*, after the polymeric material is introduced into the putter head structure and hardened, *e.g.*, by a cutting or machining process). Fig. 2C illustrates an example putter face structure in which the scorelines 210 are formed at the junctions of the bottom of a polymeric portion 204b and the top of the adjacent metal portion 204a. If desired, this structure could be flipped such that the scorelines 210 are formed at the junctions of the top of a polymeric portion 204b and the bottom of the adjacent metal portion 204a. Fig. 2D, on the other hand, illustrates another example putter face structure in which the scorelines 210 are formed: (a) at the junctions of the bottom of a polymeric portion 204b and the top of the adjacent metal portion 204a and (b) at the junctions of the top of a polymeric portion 204b and the bottom of the adjacent metal portion 204a. In other words, in the structure of Fig. 2C, at least some of the metal portions 204a and the polymeric portions 204b have a single groove defined therein, whereas in the structure of Fig. 2D, at least some of the metal portions 204a and the polymeric portions 204b have a two grooves defined therein (one groove at their top and one groove at their bottom).

- [39] Providing scorelines (*e.g.*, like scorelines 210) can affect the manner in which the ball leaves the putter head during the course of a putt. For example, the scorelines 210 can affect launch angle and/or ball spin as the ball leaves the putter face during a putt. As one more specific example, in at least some instances, the scorelines 210 and the polymeric material 204b will grip the ball somewhat and produce top spin on the ball when putted, which tends to get the ball rolling earlier and truer (*e.g.*, and eliminates some early bouncing during a putt).
- [40] The scorelines 210 may have any desired height without departing from this invention. For example, if desired, the scorelines 210 may extend up to 10% of the

height of the portion 204a and/or 204b into which it is provided, and in some examples, up to 25% or even up to 50% or 75% of this height. The scorelines 210 may extend into the portions 204a and/or 204b (in the front-to-rear or depth direction) a distance of about 0.25 to 2 times the scoreline's height, and in some examples, from 0.5 to 1.5 times the scoreline's height. The various scorelines 210 on a putter face 204 may have the same or different sizes and/or shapes, and every junction and/or every portion 204a and/or 204b on a given putter structure need not include an associated scoreline 210.

[41] The scorelines 210 may have other constructions without departing from this invention. For example, as illustrated in Fig. 3, the scorelines 210 may be formed solely in the material making up the polymeric portion 204b of the ball striking face structure 204. Alternatively, as illustrated in Fig. 4, the scorelines 210 may be formed solely in the material making up the metal (or other base material) portion 204a of the ball striking face structure 204. As yet another example, if desired, scorelines 210 of the types illustrated in Figs. 2C, 2D, 3, and/or 4 may be combined in a single putter head structure without departing from this invention. Also, if desired, in the structures of Figs. 3 and 4, grooves may be provided at both the tops and the bottoms of the polymeric portions 204b (Fig. 3) or the metal portions 204a (Fig. 4), without departing from this invention.

[42] Figs. 5-9 illustrate additional potential features of putter head structures in accordance with at least some examples of this invention. For example, Fig. 2A illustrates the openings 206 extending rearward from the ball striking face 204 in a direction generally perpendicular to the ball striking face 204. This is not a requirement. For example, as illustrated in Fig. 5, the openings 206 may extend rearward from the ball striking face 204 at a non-perpendicular angle (angle α) with respect to the ball striking face. This angle α may be in the range of 10-80°, and in some putter structures, in the range of 30-60°. Of course, the openings 206 in a given putter head structure need not extend rearward in parallel (in other words, the rearward extension angle α of the various openings 206 may vary in a single putter head structure without departing from this invention).

[43] Other variations in the putter head structure are possible without departing from this invention. For example, the port 208a of the cavity 208 need not be in the bottom

surface of the putter head, as shown in Fig. 2A. Rather, as shown in Fig. 6, the port 208a may be provided in the top surface of the putter head. In this manner, if desired (and as will be described in more detail below in conjunction with Fig. 15), the visible polymeric (or other material) present at the port 208a may provide at least a portion of an alignment aid for the putter head. While the polymeric material within the cavity 208 may be exposed at the port 208a (and at any of the ports described above), if desired, the port 208a may be closed by a cover element so that the polymeric material is not directly exposed to the exterior environment at the port 208a.

- [44] As another potential alternative structure, if desired, more than one port 208a may be provided with access to the cavity 208. For example, Fig. 7 illustrates a putter head structure in which both the top and bottom surfaces of the putter head include a port member 208a with direct access to the cavity 208. Either or both of these ports 208a may be used when filling the cavity 208 and the openings 206 with polymeric material (as will be described in more detail below in conjunction with Fig. 16).
- [45] Fig. 8 illustrates yet another example port configuration for a putter structure that may be used in accordance with at least some examples of this invention. As shown in Fig. 8, in this putter head structure the port 208a is provided in a rear face surface of the putter structure. Such a port 208a location may be desirable, for example, when the putter body is made of a relatively heavy material (such as a relatively heavy metal material) and/or removal of a relatively large amount of this material is desired to lighten the overall putter head structure (*i.e.*, the larger distance between the cavity 208 and the port 208a will require the removal of a larger amount of metal material to place the port 208a in direct fluid communication with the cavity 208. Of course, more than one port 208a may be provided on the rear surface (or on another surface) of the putter structure, if desired. The port 208a may have the same dimensions as a cross section of the cavity 208 to which it leads (*e.g.*, the same width and height, the same diameter, the same shape, etc.) or these dimensions or shapes may be different from one another.
- [46] While all of the above examples illustrated a putter structure with one main body part and the polymeric material inserted therein, the invention is not limited to this configuration. Rather, the putter main body may be constructed from multiple parts without departing from this invention. Fig. 9 illustrates an example putter head

structure 900 in which the putter head includes a ball striking face portion 902 that is engaged with a main body portion 904. Any desired manner of engaging the ball striking face portion 902 with the main body portion 904 may be used without departing from this invention. For example, these portions 902 and 904 may be engaged by mechanical connectors (*e.g.*, threaded connectors, rivets, etc.), by fusing techniques (*e.g.*, welding, brazing, soldering, etc.), by cements or adhesives, by combinations of these manners, and/or in other manners. Other numbers and combinations of parts may be provided in the overall putter head structure without departing from this invention.

[47] Fig. 9 illustrates additional potential features of putter heads in accordance with this invention. In this example structure 900, no external port 208a with access to cavity 208 is present. Rather, in this example structure 900, the cavity 208 is defined in a surface 906 of the main body portion 904 to which the striking face portion 902 is connected (the striking face portion 902 includes the openings 206 defined therein). The openings 206 and cavity 208 may be filled with polymeric material through one or more of the openings 206 located on the ball striking face 204. As additional alternatives, if desired, the cavity 208 may be defined in the rear surface of the striking face portion 902, or the cavity 208 may be partially defined in each of the portions 902 and 904. As yet an additional potential alternative, if desired, the cavity 208 may be omitted (and the various openings 206 may be separately filled with the polymeric material). A single putter head structure also may include any combination of these features, without departing from this invention.

[48] The openings on the ball striking face through which the polymeric material is exposed also may have a wide variety of configurations without departing from this invention. Figs. 1A and 2A illustrate the openings (and thus the exposed polymeric material) as a plurality of elongated, continuous slots that extend across the majority of the ball striking face. This is not a requirement. For example, as illustrated in Fig. 10, the ball striking face may include multiple sets of separated openings filled with polymeric material. These sets of openings may align with one another or may be offset from one another as one moves across the ball striking face. The sets of openings may extend to a common cavity in the body member, to different cavities, or to no common cavity at all, if desired. While not illustrated in Fig. 10, if desired, the

exposed surfaces of the sets of separated openings may be oriented at different angles from one another and/or may extend rearward at different angles from one another. As yet another example, if desired, the openings within a set need not be parallel to one another.

- [49] The openings (and thus the exposed polymeric material on the ball striking surface) are not limited to narrow, elongated slots, as illustrated in the previous examples. Rather, if desired, all or some portion of the openings may be of a different shape, *e.g.*, to produce a stylized design, pattern, alphanumeric information, or other information on the ball striking face, such as a logo, manufacturer name, brand name, or trademark information, as illustrated in Fig. 11. This feature also may be used to customize the putter head, *e.g.*, to include a personal name (such as the putter owner's name), a team name, or any other desired information, or to provide an end user (such as the club purchaser or other person) with the ability to design his or her own putter face.
- [50] Fig. 12A illustrates yet another pattern of openings (and thus another pattern of exposed polymeric material on the ball striking face surface). In this example construction, the ball striking face includes the openings and the polymeric material arranged in an arched or curved pattern across the ball striking surface. In this structure (as well as the other opening/exposed polymeric material structures described above), grooves or scorelines may be included in the polymeric material, in the material between the polymeric material, or both, *e.g.*, as described above in conjunction with Figs. 2C, 2D, 3, and 4.
- [51] Fig. 12B illustrates another pattern of openings (and thus another pattern of exposed polymeric material on the ball striking face surface). In this example construction, the ball striking face includes the openings and the polymeric material arranged in linear segments across the ball striking surface. In the center of the putter face, a series of generally horizontal linear segments 1202 are provided (when the putter is oriented in a ball address position, as shown in Fig. 12B), and on at least some of these horizontal segments 1202, slanted, linear, downwardly extending end segments 1204 are provided that extend contiguously with the horizontal segments 1202. Any desired angle θ between the slanted, linear end segments 1204 and the horizontal segments 1202 may be provided without departing from this invention. In some more specific

examples, θ may be in the range of 10-80°, and in some structures, between 20-70° or even between 30-60°, and the various angles θ within a single putter head may be the same or different without departing from this invention. In addition, if desired, one or more individual slanted segments 1206 may be provided independent of horizontal segments, *e.g.*, at the upper edges of the overall polymeric segment design (running parallel to or substantially parallel to slanted segments 1204 associated with a horizontal segment). As other alternatives, if desired, the slanted segments 1204 and/or 1206 may be parallel or non-parallel, may extend upward or downward, may differ in number from those illustrated, may be discontinuous (spaced apart somewhat) from their associated horizontal segment 1202 (if any), may all extend downward to a common base line of the putter structure (*e.g.*, to a common horizontal line), may all extend downward to different horizontal locations, etc. In this illustrated structure (as well as the other opening/exposed polymeric material structures described above), grooves or scorelines may be included in the polymeric material, in the material between the polymeric material, or both, *e.g.*, as described above in conjunction with Figs. 2C, 2D, 3, and 4. The slanted segments 1204 and/or 1206 (as well as any grooving or scorelines associated therewith), may help keep the ball on the desired line when hit off-center from the putter face.

- [52] The overall pattern of exposed polymeric material at the putter face may extend and span any desired amount across the putter face in the heel-to-toe direction, such as from 25-100% of the face's heel-to-toe direction, from 30-90% of the face's heel-to-toe direction, or even from 40-80% of the face's heel-to-toe direction. In some example structures in accordance with this invention, the overall pattern of exposed polymeric material at the putter face may extend across at least the central 25% of the face in the heel-to-toe direction, and in some examples, the polymeric material will extend across at least the central 40% of the face or across at least the central 50% of the face in the heel-to-toe direction.
- [53] Aspects of this invention may be practiced with any desired putter head construction without departing from this invention. Figs. 1A through 12B illustrate aspects of the invention included in various mallet type golf putter head structures. As illustrated in Fig. 13, aspects of this invention also may be practiced with blade type putter heads.

- Fig. 14 illustrates aspects of this invention practiced in a high moment of inertia, large size putter head construction.
- [54] Fig. 15 illustrates aspects of this invention practiced in yet another putter head construction 1500. In this example structure 1500, the port providing access to the cavity defined in the putter body is provided in the top surface 1504 of the putter head's ball striking face 1506. In this structure 1500, the exposed polymeric material 1502 at the top surface 1504 of the putter head 1500 forms a portion of the alignment aid for the putter head 1500. This exposed top surface 1504 port may extend any desired distance along the top of the putter head, *e.g.*, from 25-100% of the overall heel-to-toe width of the putter head at the location of the port, and in some examples, from 50-95% and even from 50-85% of the overall heel-to-toe width at the location of the port. As noted above, however, rather than directly exposing polymeric material 1502, the port may be closed by a cover member to prevent direct exposure of the polymeric material 1502. The exposed polymeric material and/or the cover member may be made of any desired color without departing from this invention.
- [55] The invention is not limited to use in the various putter constructions shown. Rather, aspects of this invention may be used in the construction of any desired putter construction, including general putter constructions and styles that are known and used in the art.
- [56] Fig. 16 generally illustrates a manner of making a putter head construction in accordance with examples of this invention. The method begins with a general putter body 1600 (or a putter ball striking face member) into which a cavity 1608 has been provided and into which a plurality of openings 1606 have been provided in the ball striking surface 1604. The cavity 1608 and the openings 1606 may be provided in the putter body structure 1600 in any desired manner without departing from the invention, such as by machining them in, by molding or casting them in, by forging, etc. Liquid polymer material (or a precursor thereof) 1610 is introduced into the cavity 1608 via port 1608a. The liquid polymer material 1610 flows from the cavity 1608 to fill the openings 1606 and the channels extending rearward therefrom. If desired, prior to introducing the polymer material 1610, the putter body 1600 (or at least some portions thereof) may be fit into a mold or other suitable structure to hold the liquid polymer in place. The polymeric material 1610 may be introduced by

pouring, by injection molding processes (*e.g.*, under pressure), or the like. Once introduced, if necessary, the polymeric material 1610 may be exposed to conditions that enable it to harden, such as to cool temperatures; to high temperatures; to pressure; to ultraviolet, infrared, or other radiation; etc. The final putter body 1650 (including the cured polymeric material 1610 therein), may be further processed in any desired manner, *e.g.*, by painting, anodizing, or other finishing processing; by cutting scorelines or grooves into the face of the putter head (*e.g.*, as described above); by adding a shaft and/or grip member to the club head; etc.

[57] Any desired polymeric material may be used without departing from this invention, including thermoplastic or thermosetting polymeric materials, synthetic rubber type polymeric materials, etc., such as polyurethanes, vinyls (*e.g.*, ethylvinylacetates, etc.), nylons, polyethers, polybutylene terephthalates, etc.

[58] Putters and putter heads may have any desired constructions, materials, dimensions, loft angles, lie angles, colors, designs, and the like without departing from this invention, including conventional constructions, materials, dimensions, loft angles, lie angles, colors, designs, and the like, as are known and used in the art.

CONCLUSION

[59] Of course, many modifications to the putter and putter head structures and/or methods for making these structures may be used without departing from the invention. For example, with respect to the structures, grips, aiming indicia or markings, other indicia or markings, different types of putter heads, various shaft curvatures and/or shapes, various shaft connecting member shapes, and/or other structural elements may be provided and/or modified in the structure without departing from the invention. With respect to the methods, additional production steps may be added, various described steps may be omitted, the steps may be changed and/or changed in order, and the like, without departing from the invention. Therefore, while the invention has been described with respect to specific examples including presently preferred modes of carrying out the invention, those skilled in the art will appreciate that there are numerous variations and permutations of the above described structures and methods.

Thus, the spirit and scope of the invention should be construed broadly as set forth in the appended claims.

We Claim:

1. A putter head, comprising:
a putter body including a ball striking face member made of a material having a first hardness characteristic, wherein a cavity is defined in the putter body behind the ball striking face member, and wherein a plurality of independent and separated openings are defined in the ball striking face member, the independent and separated openings extending rearward with respect to the ball striking face member so as to open into the cavity; and
a polymeric material provided to at least partially fill the plurality of openings and the cavity, wherein the polymeric material has a second hardness characteristic that is softer than the first hardness characteristic, and wherein the ball striking face member and the polymeric material exposed in at least some of the openings provide a ball striking surface of the putter head.
2. A putter head according to claim 1, wherein the polymeric material completely fills the plurality of openings and the cavity.
3. A putter head according to claim 1, wherein the ball striking surface has a plurality of grooves defined therein.
4. A putter head according to claim 3, wherein the grooves are defined in the material making up the ball striking face member.
5. A putter head according to claim 4, wherein the grooves extend into only a portion of an exposed surface of the material making up the ball striking face member between adjacent openings in the ball striking face member.
6. A putter head according to claim 3, wherein the grooves are defined in the polymeric material.
7. A putter head according to claim 6, wherein the grooves extend into only a portion of an exposed surface of the polymeric material provided in an opening in the ball striking face member.
8. A putter head according to claim 3, wherein the grooves are defined in the material making up the ball striking face member and in the polymeric material.
9. A putter head according to claim 1, wherein the plurality of openings are arranged in a parallel manner such that the material of the ball striking face member extends between two adjacent openings.

10. A putter head according to claim 9, wherein the ball striking face member includes at least four openings arranged in a parallel manner.

11. A putter head according to claim 1, wherein the plurality of openings are arranged in a manner such that the material of the ball striking face member extends between two adjacent openings.

12. A putter head according to claim 11, wherein the ball striking surface has a plurality of grooves defined therein.

13. A putter head according to claim 12, wherein the grooves are defined in the material making up the ball striking face member and in the polymeric material.

14. A putter head according to claim 12, wherein the grooves are defined in and at adjacent portions of the material making up the ball striking face and in the polymeric material.

15. A putter head according to claim 1, wherein the cavity extends to and opens at an exterior surface of the putter body.

16. A putter head according to claim 15, wherein the cavity opens at a bottom surface of the putter body.

17. A putter head according to claim 15, wherein the cavity opens at a top surface of the putter body.

18. A putter head according to claim 17, wherein the polymeric material is exposed at the top surface of the putter body and forms at least a portion of an alignment aid for the putter head.

19. A putter head according to claim 15, wherein the cavity opens at a rear surface of the putter body.

20. A putter head according to claim 1, wherein, among the plurality of independent and separated openings, two adjacent openings are separated by a distance ranging from 0.03 to 0.5 inches.

21. A putter head according to claim 20, wherein the material of the ball striking face extends between and separates the two adjacent openings.

22. A putter head according to claim 1, wherein, among the plurality of independent and separated openings, two adjacent openings are separated by a distance ranging from 0.1 to 0.3 inches.

23. A putter head according to claim 1, wherein, among the plurality of independent and separated openings, each opening is separated from any adjacent opening by a distance ranging from 0.03 to 0.5 inches.

24. A putter head according to claim 23, wherein the openings are separated from adjacent openings by a constant distance when moving from a first end of an opening to a second end of the opening.

25. A putter head according to claim 23, wherein all adjacent openings in the ball striking face member are separated from one another by a constant distance.

26. A putter head according to claim 1, wherein the openings are formed as slots that extend along the ball striking face member.

27. A putter head according to claim 1, wherein the openings are formed as a plurality of parallel slots that extend along the ball striking surface.

28. A putter head according to claim 1, wherein at least some of the plurality of independent and separated openings extend rearward from the ball striking surface in a direction substantially perpendicular to the ball striking surface.

29. A putter head according to claim 1, wherein at least some of the plurality of independent and separated openings extend rearward from the ball striking surface at a non-perpendicular angle with respect to the ball striking surface.

30. A putter head according to claim 29, wherein the non-perpendicular angle is within a range of 10° to 80°.

31. A putter head according to claim 1, wherein at least one of the plurality of independent and separated openings includes a substantially horizontal linear segment extending in a heel-to-toe direction when the putter head is oriented in a ball address position, a first slanted linear segment located at a first end of the horizontal linear segment, and a second slanted linear segment located at a second end of the horizontal linear segment.

32. A putter head according to claim 1, wherein at least a portion of the plurality of openings form a logo or a design element on the ball striking surface.

33. A putter head according to claim 1, wherein at least a portion of the plurality of openings form one or more alphanumeric characters on the ball striking surface.

34. A putter, comprising:

a putter body including a ball striking face member made of a material having a first hardness characteristic, wherein a cavity is defined in the putter body behind the ball striking face member, and wherein a plurality of independent and separated openings are defined in the ball striking face member, the independent and separated openings extending rearward with respect to the ball striking face member so as to open into the cavity;

a polymeric material provided to at least partially fill the plurality of openings and the cavity, wherein the polymeric material has a second hardness characteristic that is softer than the first hardness characteristic, and wherein the ball striking face member and the polymeric material exposed in at least some of the openings provide a ball striking surface of the putter head; and

a shaft member extending from the putter body.

35. A putter according to claim 34, wherein the ball striking surface has a plurality of grooves defined therein.

36. A putter according to claim 35, wherein the grooves are defined in the material making up the ball striking face member.

37. A putter according to claim 36, wherein the grooves extend into only a portion of an exposed surface of the material making up the ball striking face member between adjacent openings in the ball striking face member.

38. A putter according to claim 35, wherein the grooves are defined in the polymeric material.

39. A putter according to claim 38, wherein the grooves extend into only a portion of an exposed surface of the polymeric material provided in an opening in the ball striking face member.

40. A putter according to claim 35, wherein the grooves are defined in the material making up the ball striking face member and in the polymeric material.

41. A putter according to claim 34, wherein the plurality of openings are arranged in a manner such that the material of the ball striking face member extends between two adjacent openings.

42. A putter according to claim 34, wherein the cavity extends to and opens at an exterior surface of the putter body.

43. A putter according to claim 34, wherein the openings are formed as slots that extend along the ball striking face member.

44. A putter according to claim 34, wherein at least some of the plurality of independent and separated openings extend rearward from the ball striking surface in a direction substantially perpendicular to the ball striking surface.

45. A putter according to claim 34, wherein at least one of the plurality of independent and separated openings includes a substantially horizontal linear segment extending in a heel-to-toe direction when the putter is oriented in a ball address position, a first slanted linear segment located at a first end of the horizontal linear segment, and a second slanted linear segment located at a second end of the horizontal linear segment.

46. A putter according to claim 34, wherein at least a portion of the plurality of openings form a logo or a design element on the ball striking surface.

47. A putter according to claim 34, wherein at least a portion of the plurality of openings form one or more alphanumeric characters on the ball striking surface.

48. A method of forming a putting device, comprising:

providing a putter body including a ball striking face member made of a material having a first hardness characteristic, wherein a cavity is defined in the putter body behind the ball striking face member, and wherein a plurality of independent and separated openings are defined in the ball striking face member, the independent and separated openings extending rearward with respect to the ball striking face member so as to open into the cavity; and

placing a polymeric material in the putter body to at least partially fill the plurality of openings and the cavity, wherein the polymeric material has a second hardness characteristic that is softer than the first hardness characteristic, and wherein the polymeric material is inserted such that the ball striking face member and the polymeric material exposed in at least some of the openings provide a ball striking surface of the putter head.

49. A method according to claim 48, wherein the providing includes machining the cavity in the putter body.

50. A method according to claim 48, wherein the providing includes machining the plurality of independent and separated openings in the ball striking face member.

51. A method according to claim 48, wherein the placing includes introducing a liquid into the putter body.

52. A method according to claim 51, wherein the liquid is introduced through a port defined in the putter body that provides access to the cavity.

53. A method according to claim 51, wherein the placing further includes converting the introduced liquid to a solid state.

54. A method according to claim 48, further comprising:
attaching a shaft member to the putter body.

55. A method according to claim 48, further comprising:
providing a plurality of grooves in the ball striking surface.

56. A method according to claim 55, wherein at least some of the grooves are provided in the material of the ball striking face member.

57. A method according to claim 55, wherein at least some of the grooves are formed in the polymeric material.

58. A method according to claim 55, wherein at least some of the grooves are formed in adjacent portions of the material of the ball striking face member and the polymeric material.

59. A method according to claim 55, wherein a first continuous groove is formed such that a first part of the first continuous groove is provided in the material of the ball striking face member and a second part of the first continuous groove is provided in the polymeric material.

60. A method according to claim 48, wherein at least one of the plurality of independent and separated openings includes a substantially horizontal linear segment extending in a heel-to-toe direction when the putter head is oriented in a ball address position, a first slanted linear segment located at a first end of the horizontal linear segment, and a second slanted linear segment located at a second end of the horizontal linear segment.

61. A putter head, comprising:

a putter body including a ball striking face member made of a material having a first hardness characteristic, wherein a cavity is defined in the putter body behind the ball striking face member, and wherein a plurality of independent and separated openings are defined in the ball striking face member, the independent and separated openings extending rearward with respect to the ball striking face member so as to open into the cavity, and at least some portion of a first opening of the plurality of independent and separated openings extending substantially horizontally along the ball striking face member when the putter head is oriented in a ball address position; and

a polymeric material provided to at least partially fill the plurality of openings and the cavity, wherein the polymeric material has a second hardness characteristic that is softer than the first hardness characteristic, and wherein the ball striking face member and the polymeric material exposed in at least some of the openings provide a ball striking surface of the putter head.

62. A putter head according to claim 61, wherein the first opening of the plurality of independent and separated openings includes a first horizontal linear segment extending in a heel-to-toe direction when the putter head is oriented in the ball address position, a first slanted linear segment located at a first end of the first horizontal linear segment, and a second slanted linear segment located at a second end of the first horizontal linear segment.

63. A putter head according to claim 62, wherein the plurality of independent and separated openings includes a second opening having a second horizontal linear segment extending in the heel-to-toe direction when the putter head is oriented in the ball address position, a third slanted linear segment located at a first end of the second horizontal linear segment, and a fourth slanted linear segment located at a second end of the second horizontal linear segment.

64. A putter head according to claim 63, wherein the first and second horizontal linear segments are parallel; the first and third slanted linear segments are parallel; and the second and fourth linear segments are parallel.

65. A putter head according to claim 63, wherein the plurality of independent and separated openings includes a third opening having a third horizontal linear segment extending in the heel-to-toe direction when the putter head is oriented in the ball address position, a fifth slanted linear segment located at a first end of the third horizontal linear

segment, and a sixth slanted linear segment located at a second end of the third horizontal linear segment.

66. A putter head according to claim 65, wherein the first, second, and third horizontal linear segments are parallel; the first, third, and fifth slanted linear segments are parallel; and the second, fourth, and sixth slanted linear segments are parallel.

67. A putter head according to claim 65, wherein the plurality of independent and separated openings includes a fourth opening having a fourth horizontal linear segment extending in the heel-to-toe direction when the putter head is oriented in the ball address position, a seventh slanted linear segment located at a first end of the fourth horizontal linear segment, and an eighth slanted linear segment located at a second end of the fourth horizontal linear segment.

68. A putter head according to claim 67, wherein the first, second, third, and fourth horizontal linear segments are parallel; the first, third, fifth, and seventh slanted linear segments are parallel; and the second, fourth, sixth, and eighth slanted linear segments are parallel.

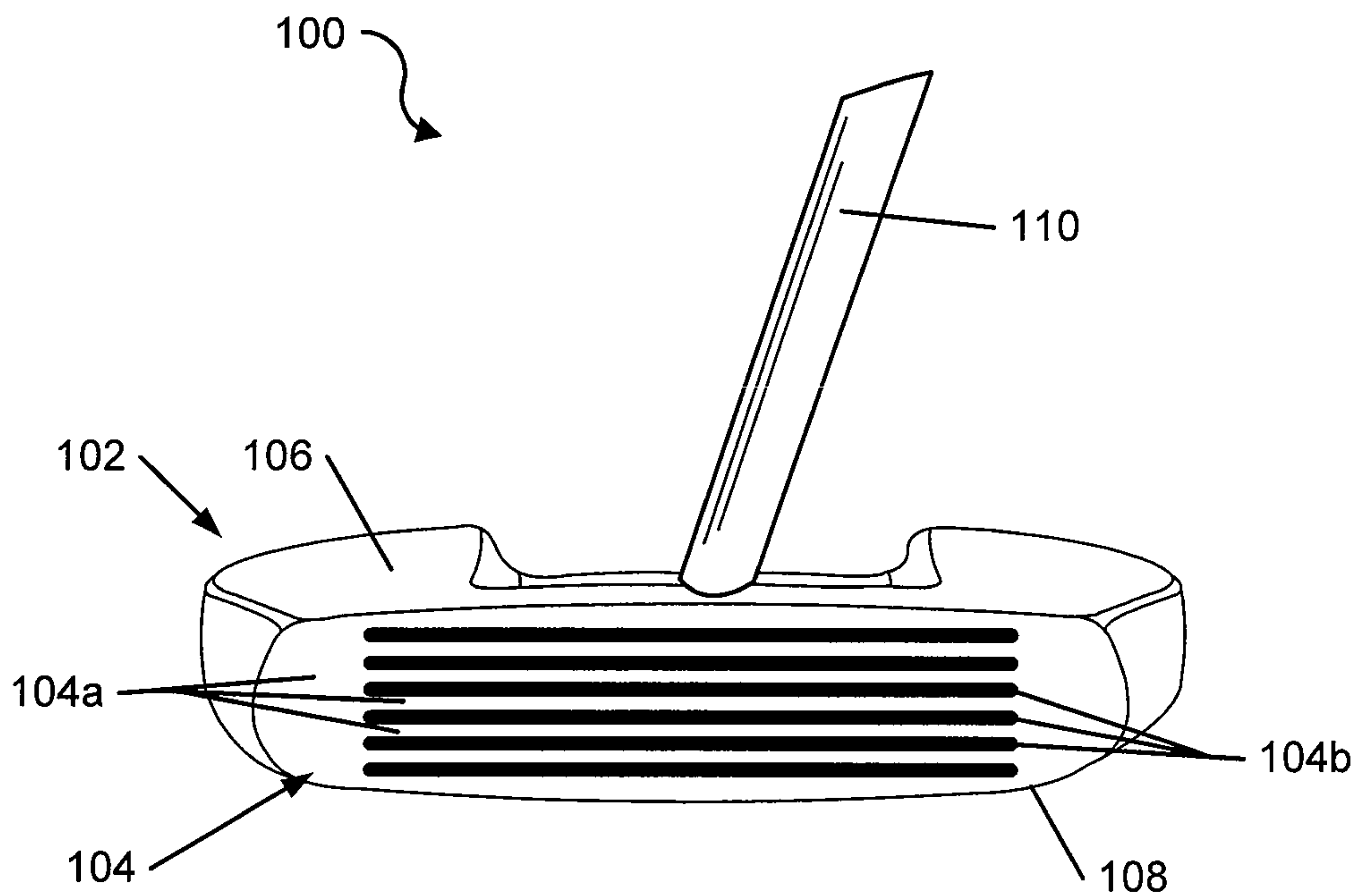

FIG. 1A

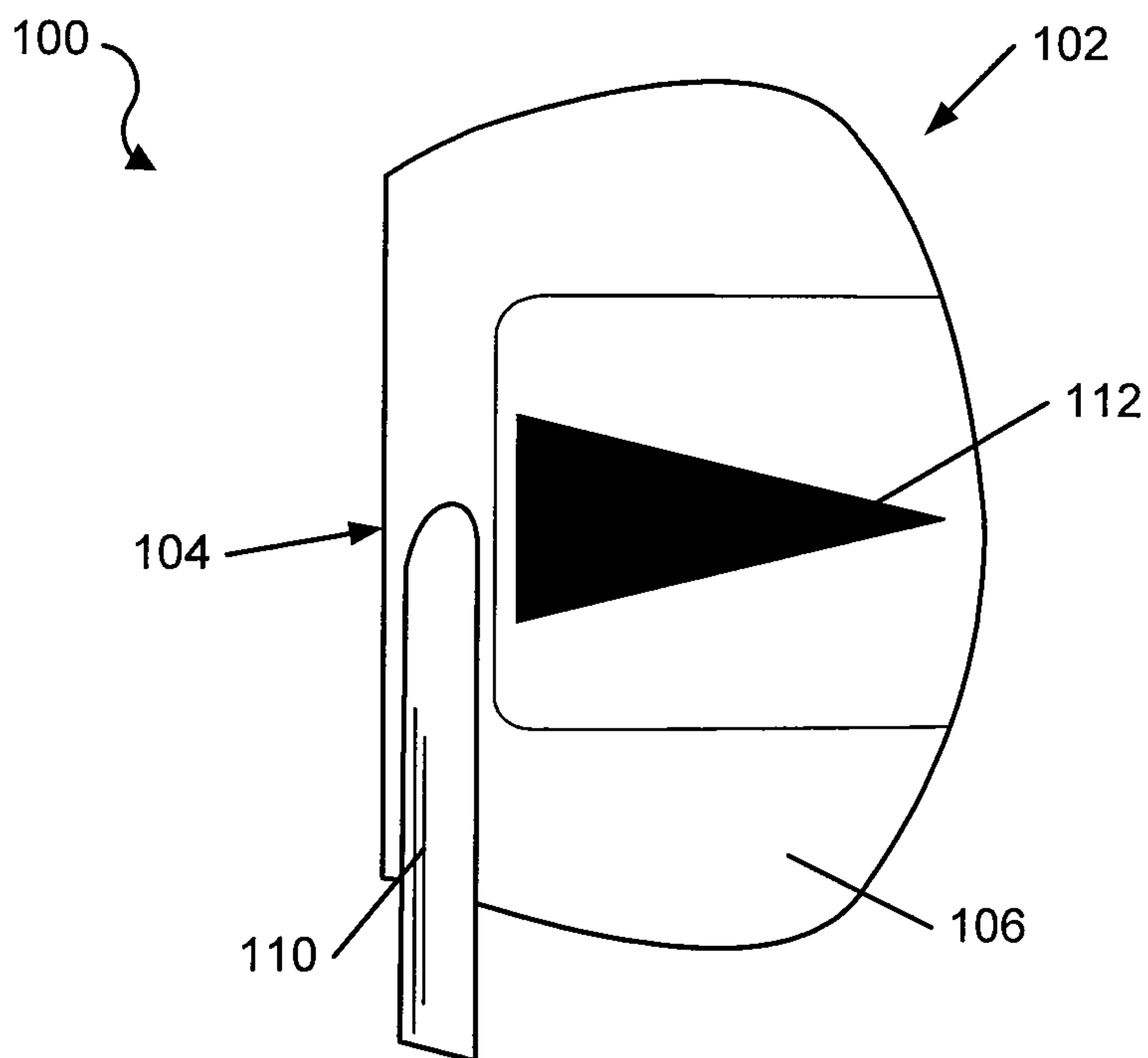

FIG. 1B

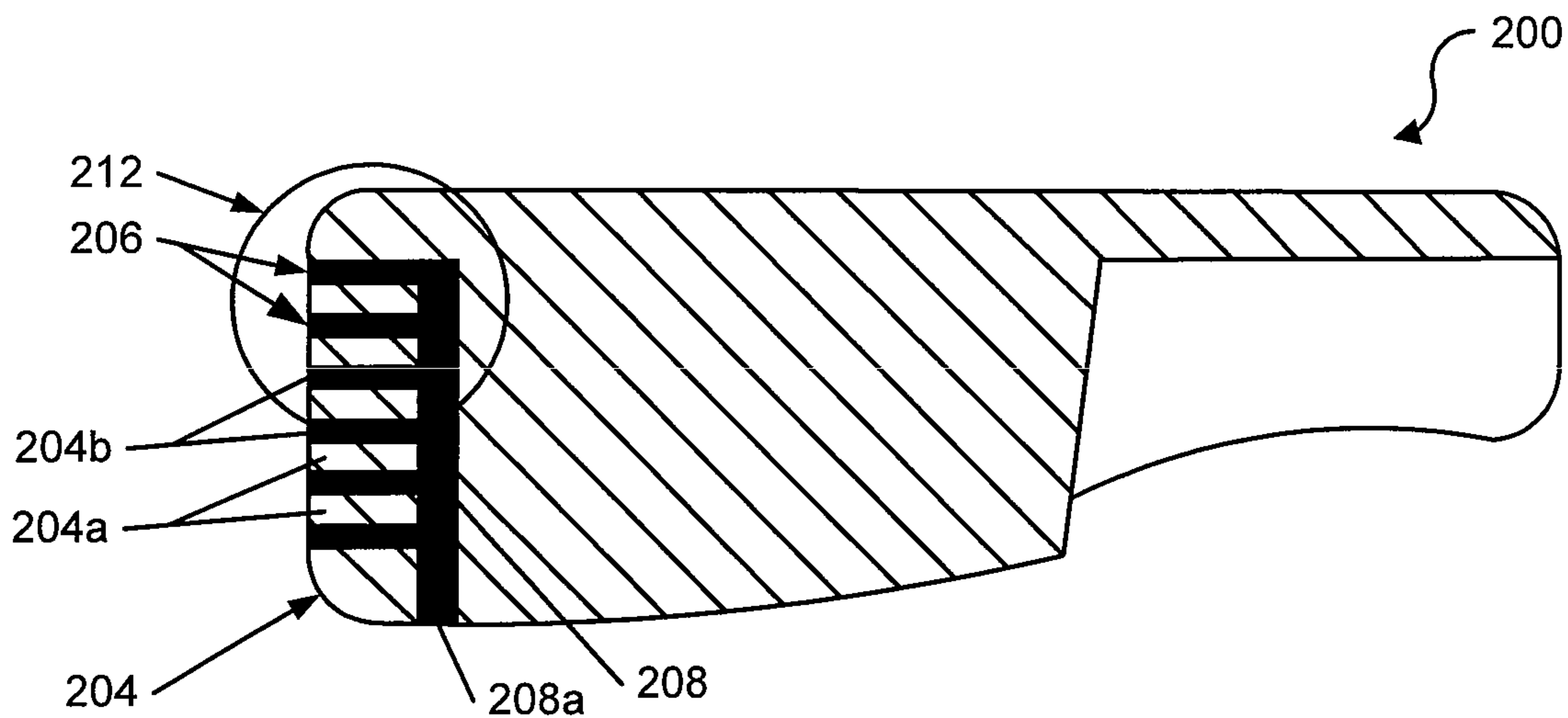

FIG. 2A

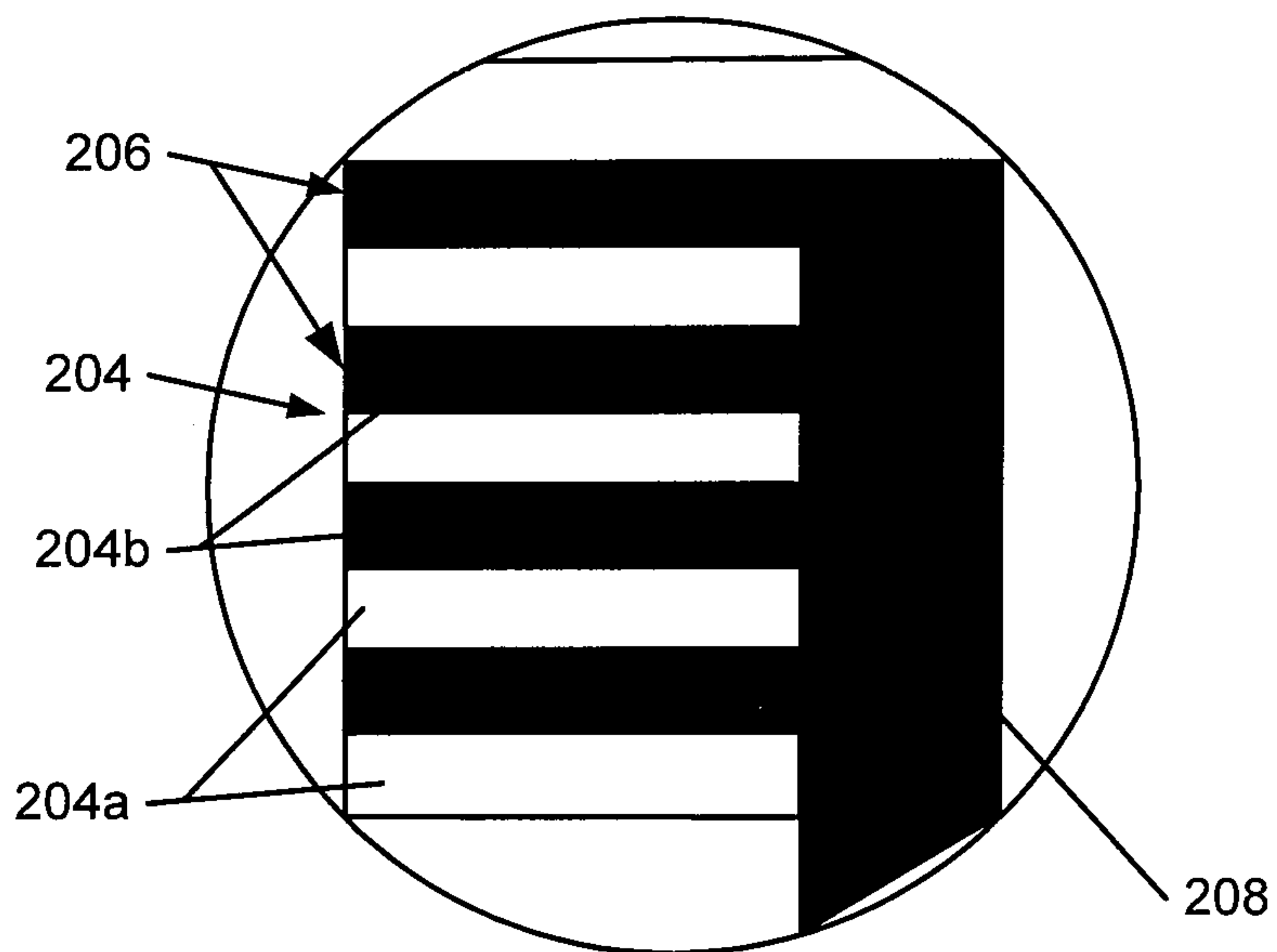

FIG. 2B

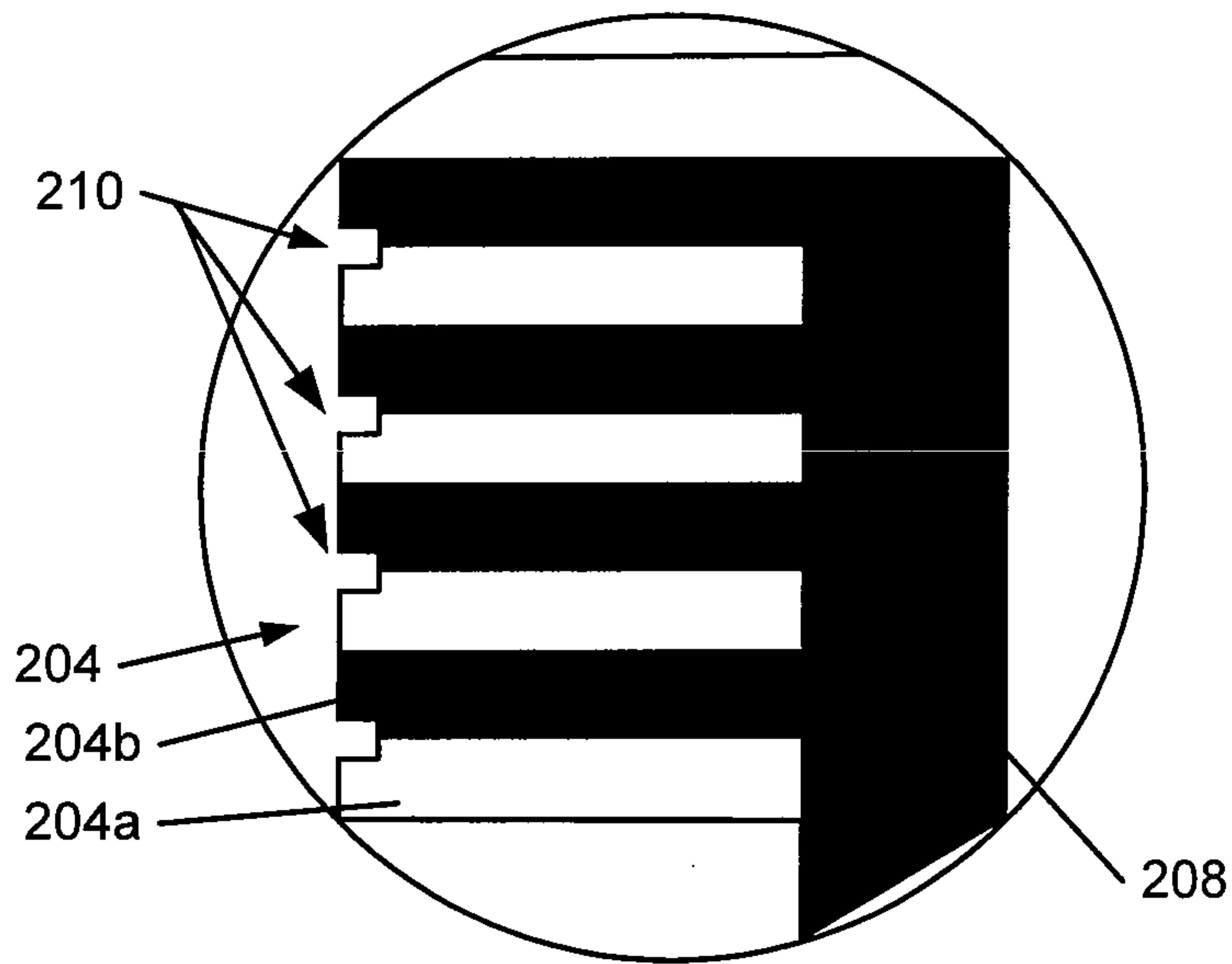

FIG. 2C

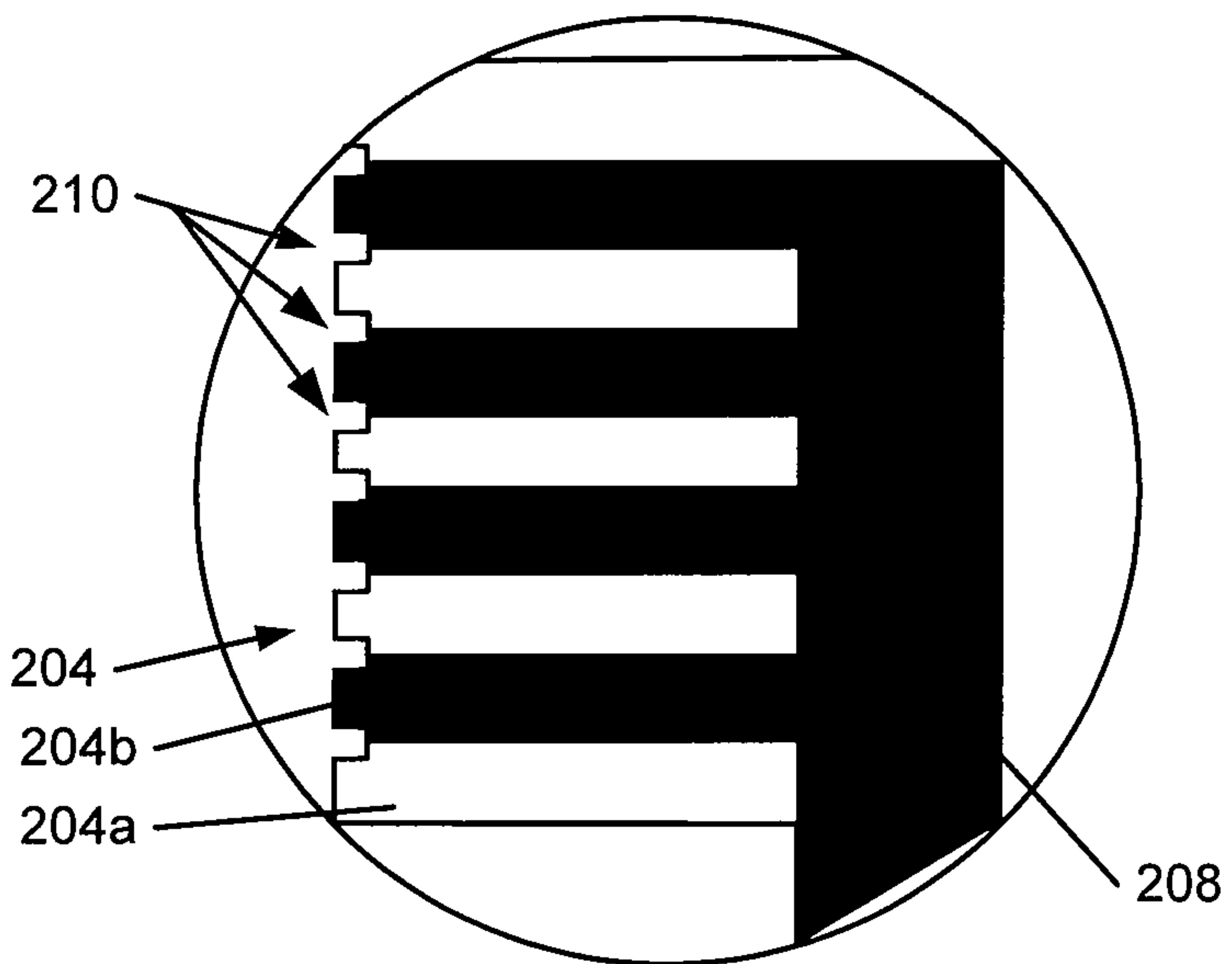

FIG. 2D

4/11

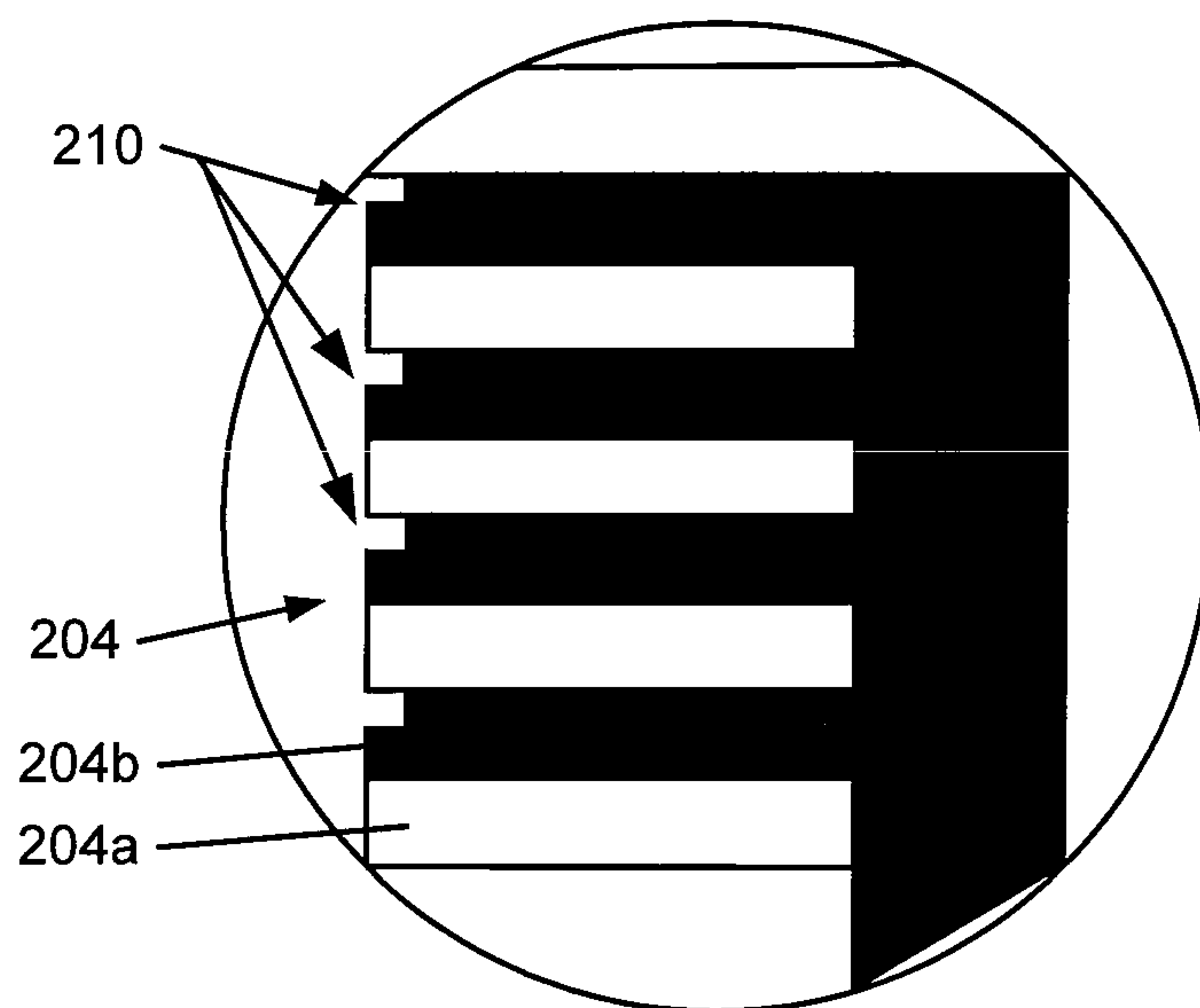

FIG. 3

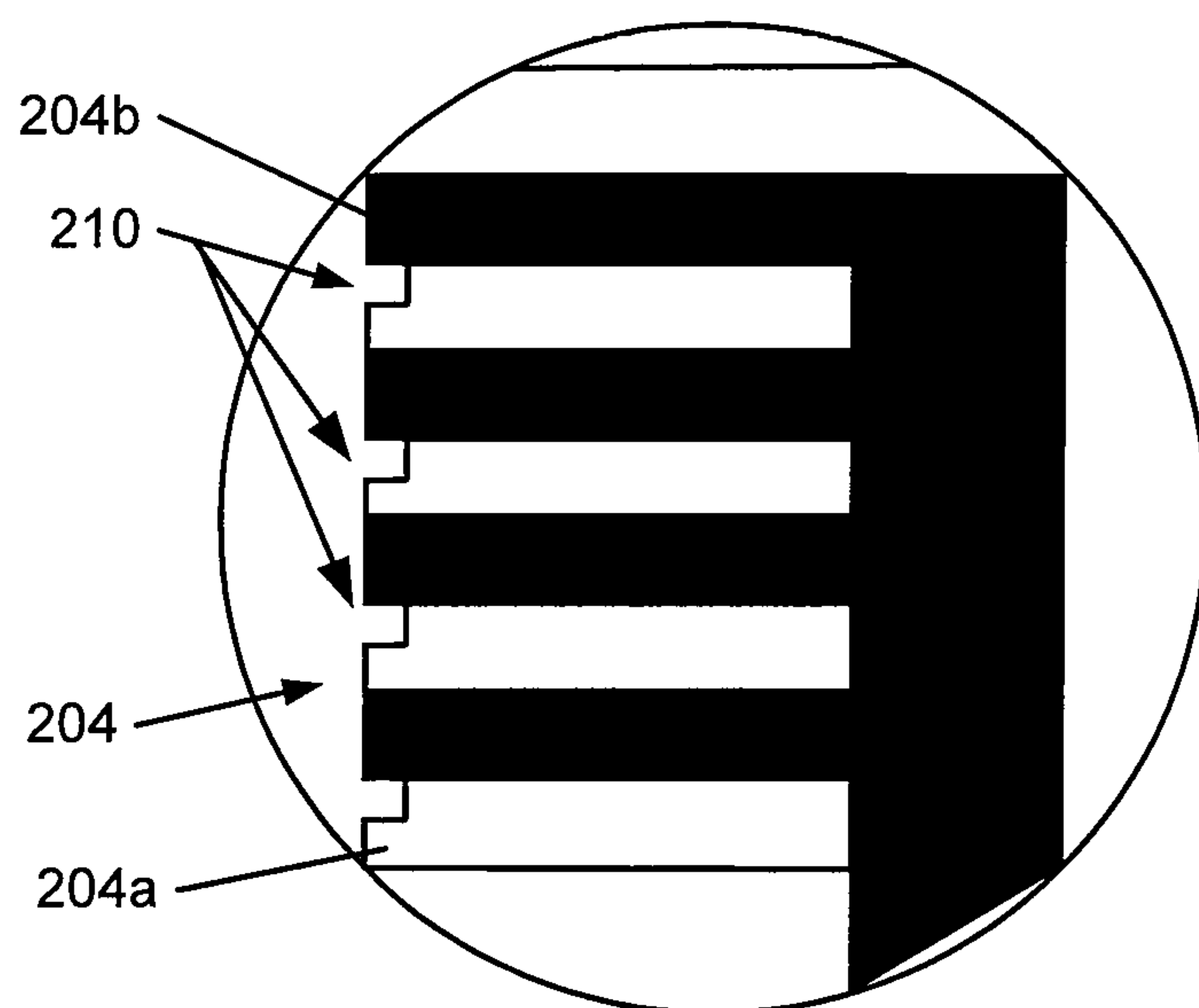

FIG. 4



FIG. 5

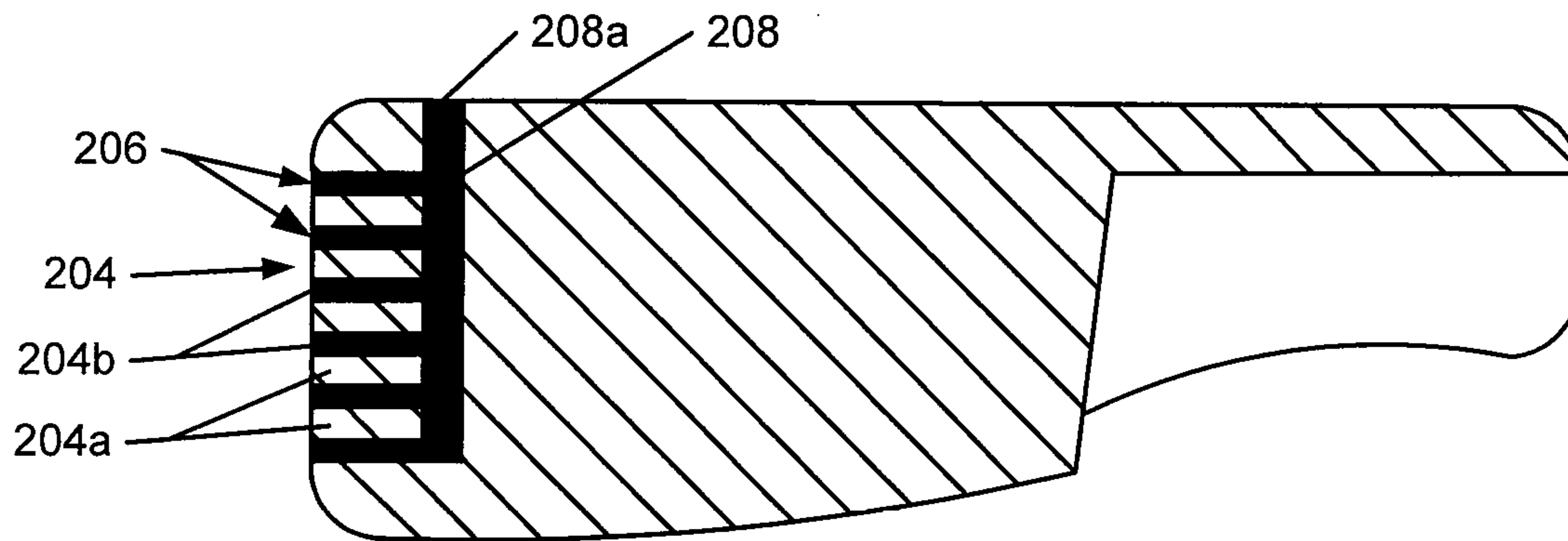

FIG. 6

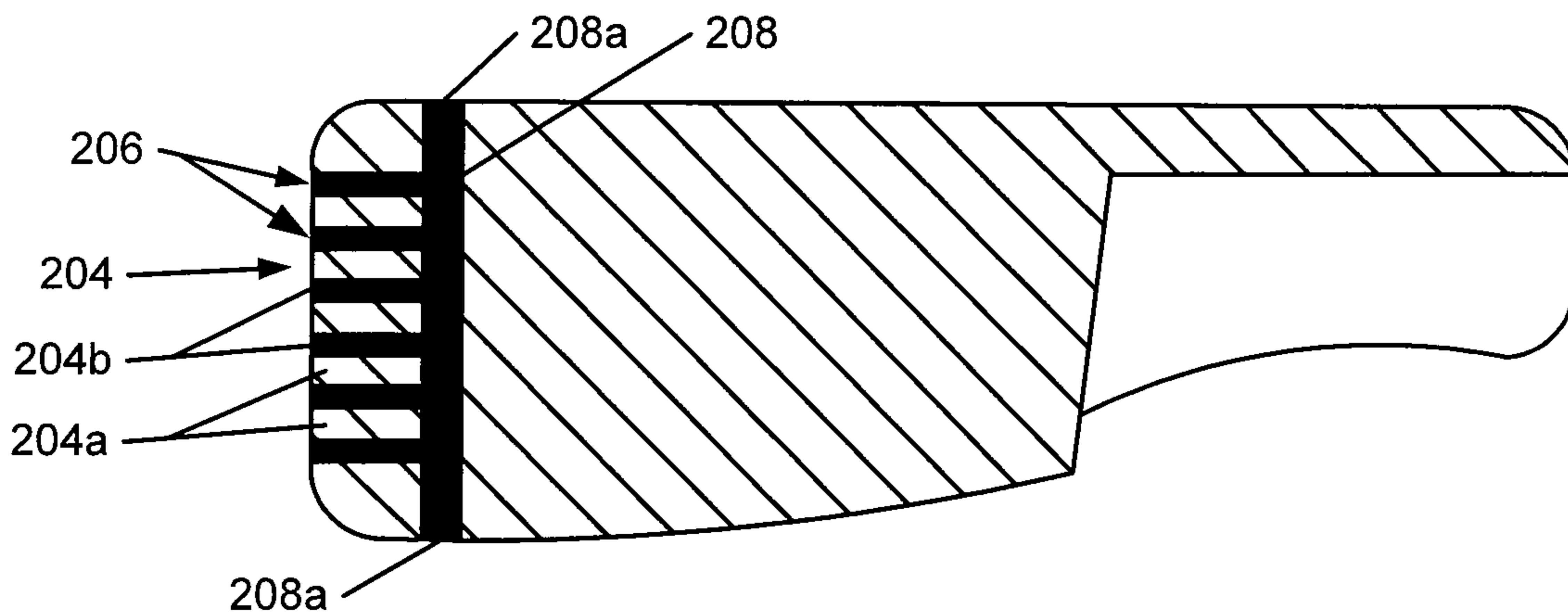

FIG. 7

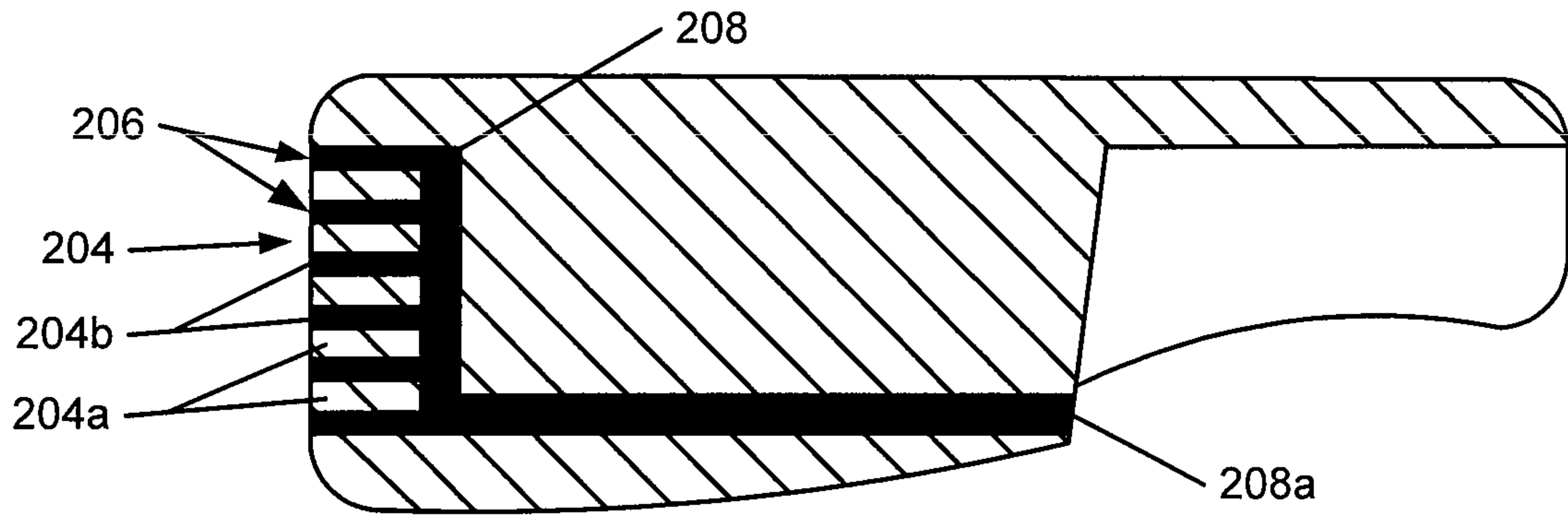

FIG. 8

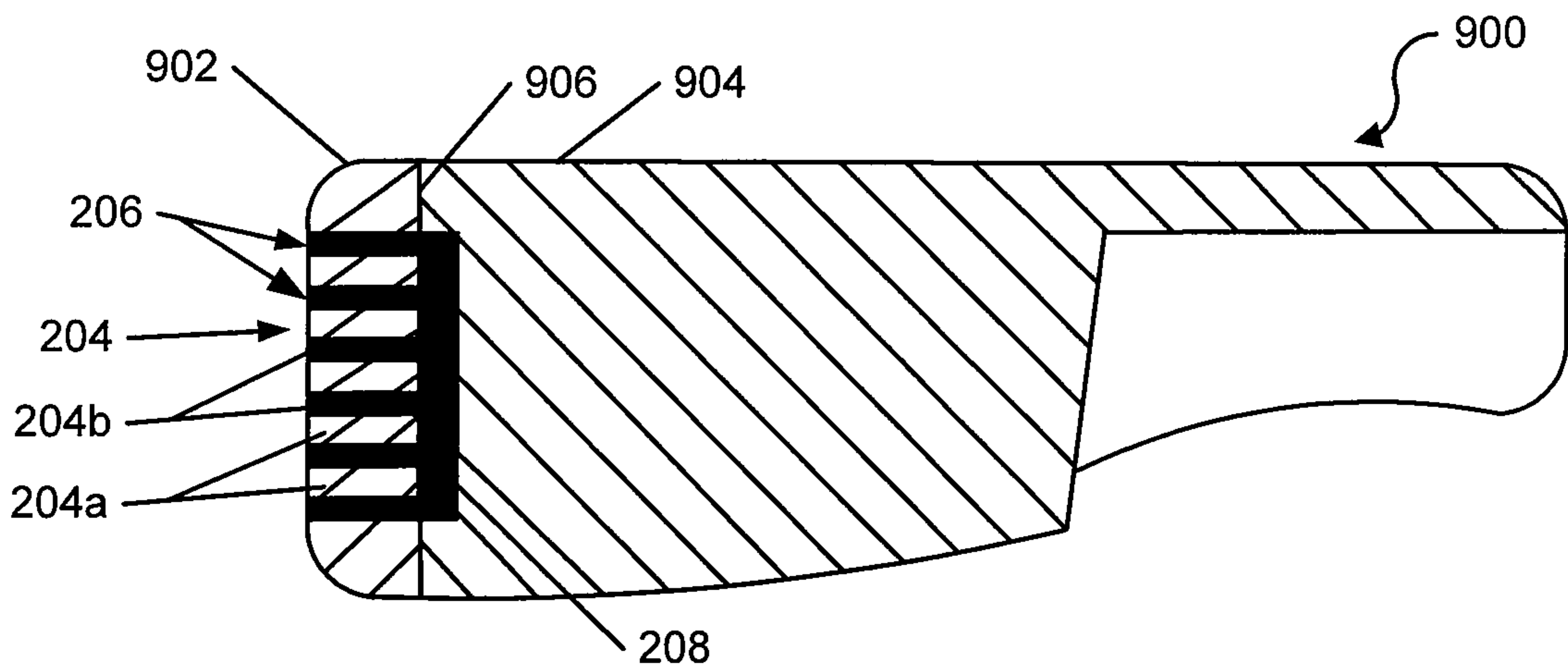

FIG. 9

7/11

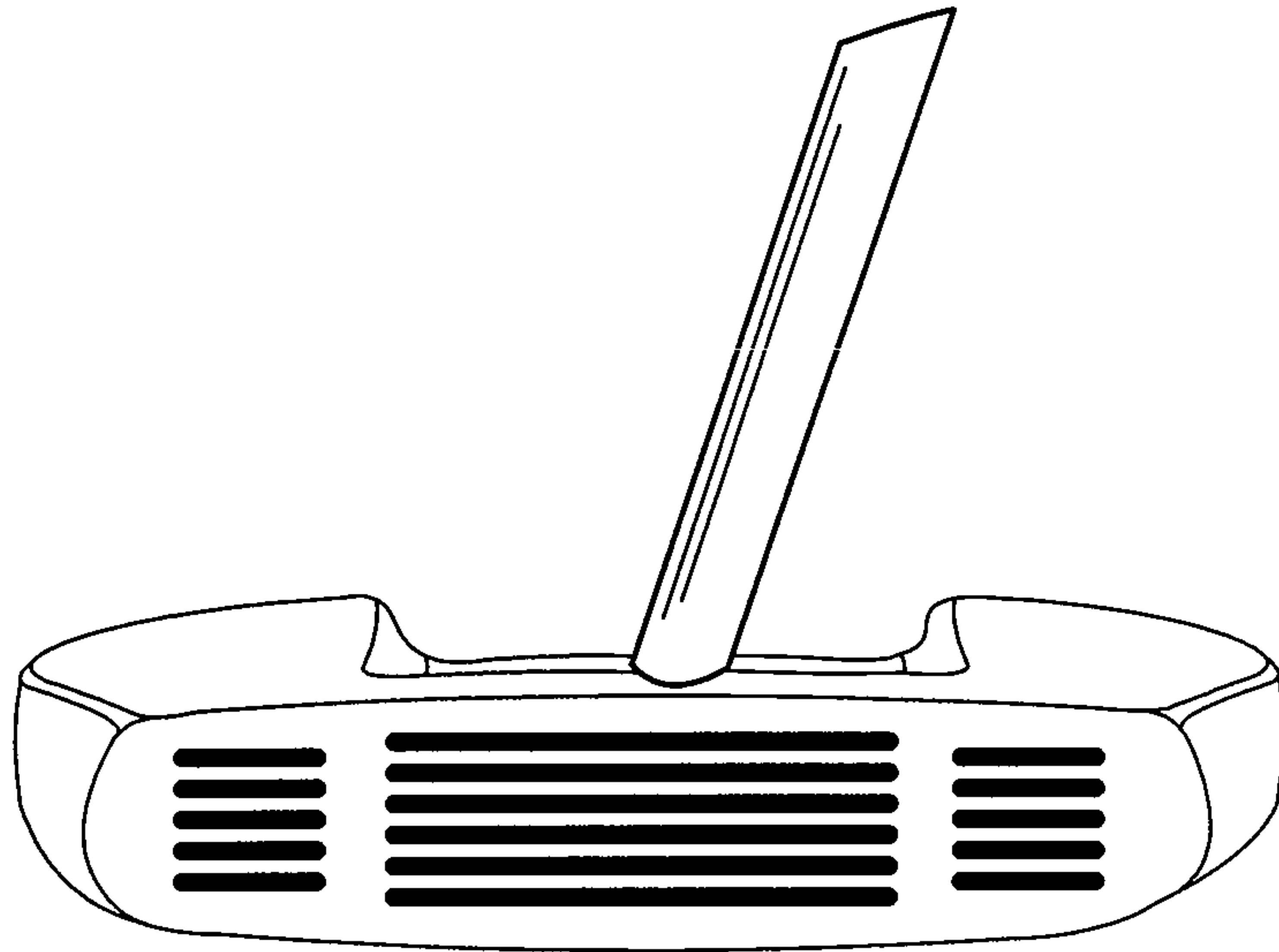

FIG. 10

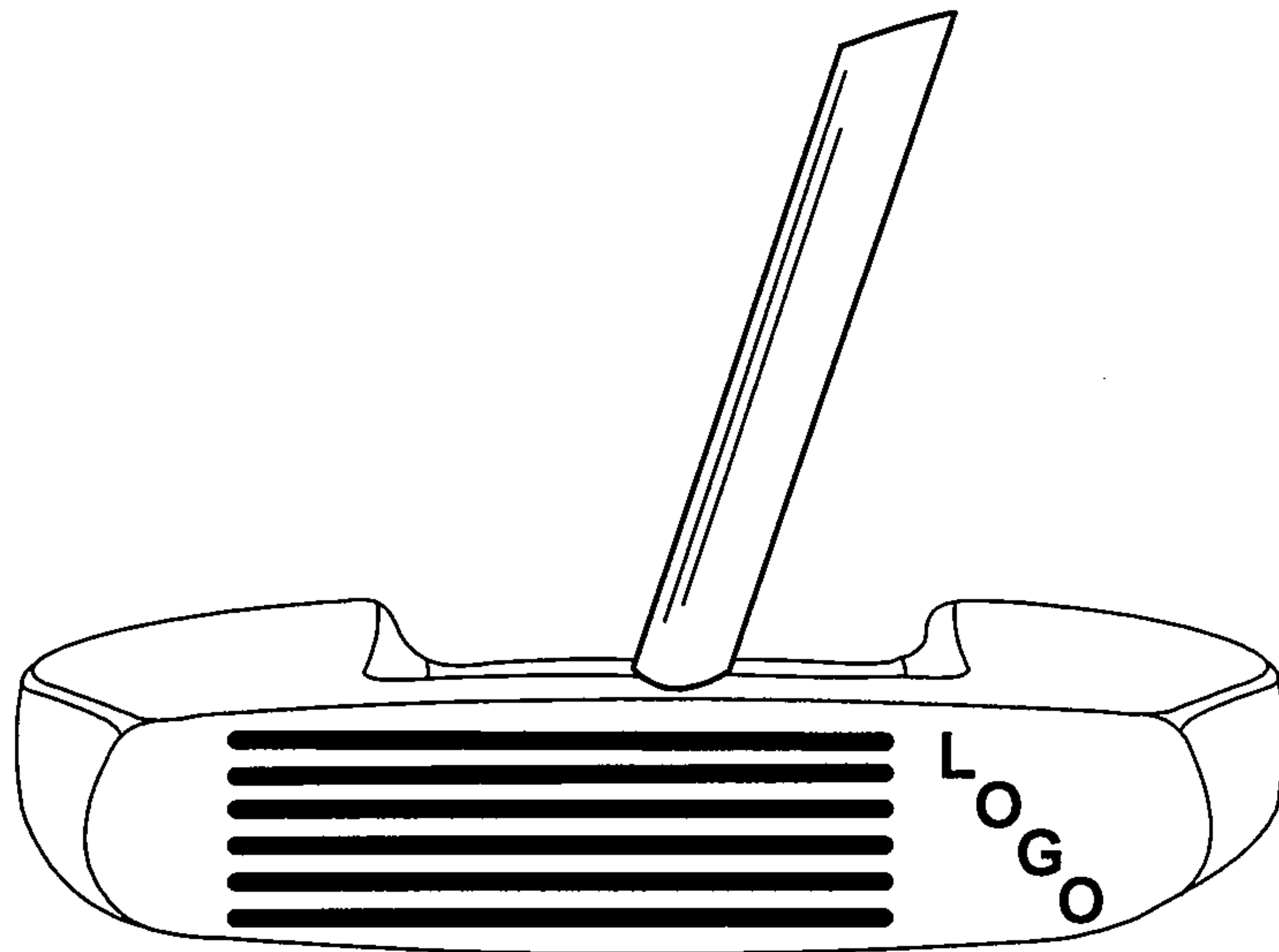

FIG. 11

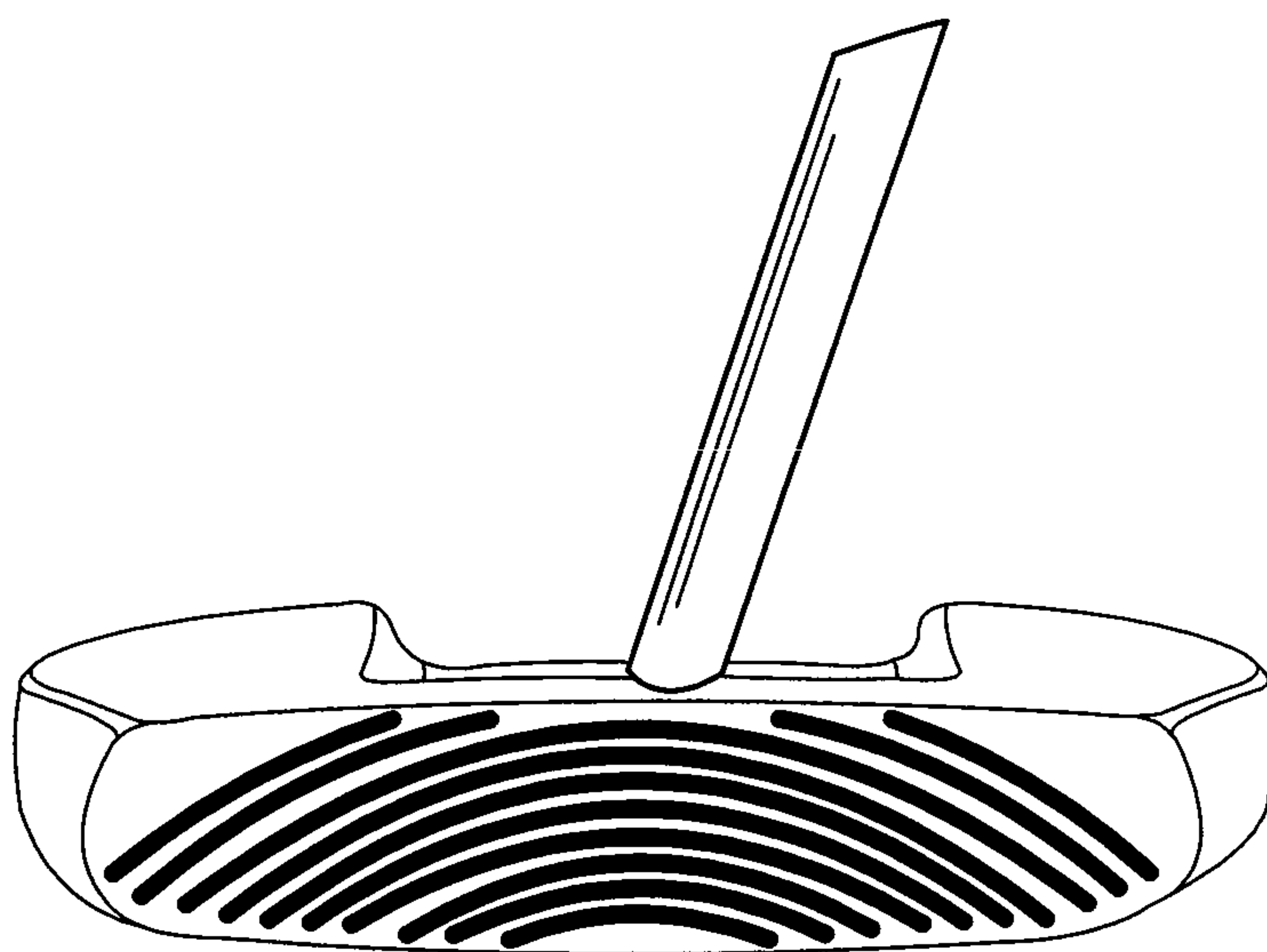

FIG. 12A

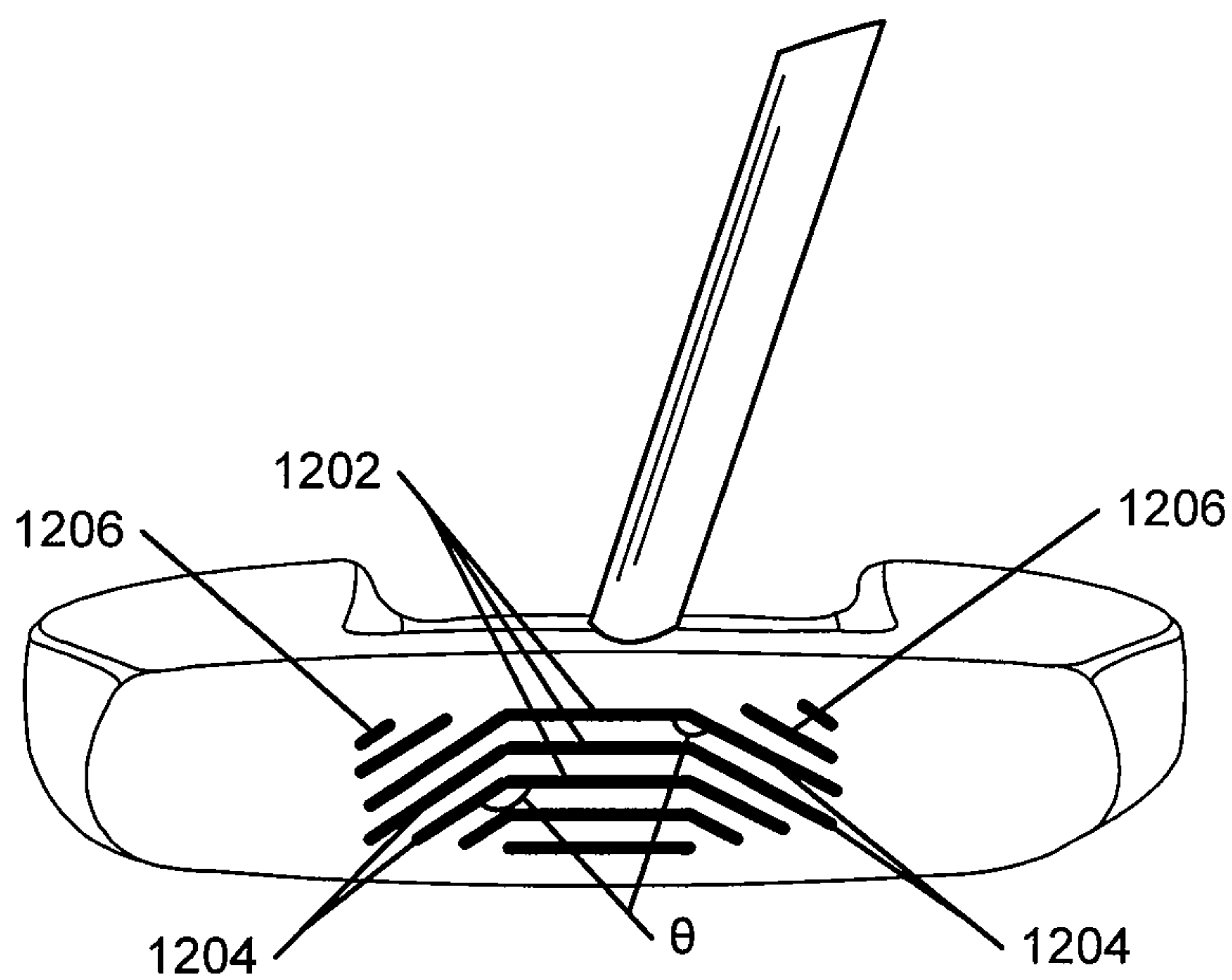

FIG. 12B

9/11



FIG. 13

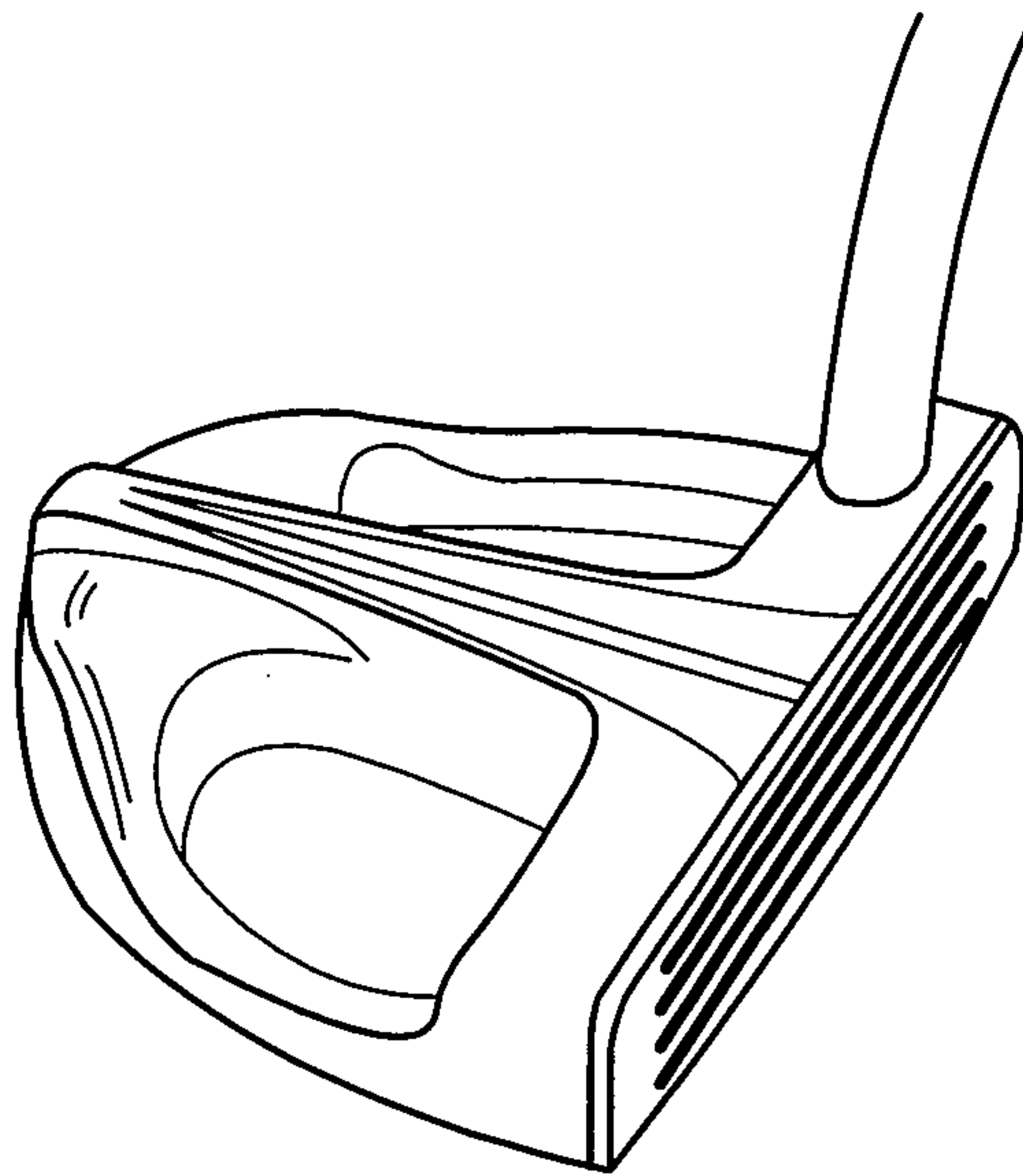

FIG. 14

10/11

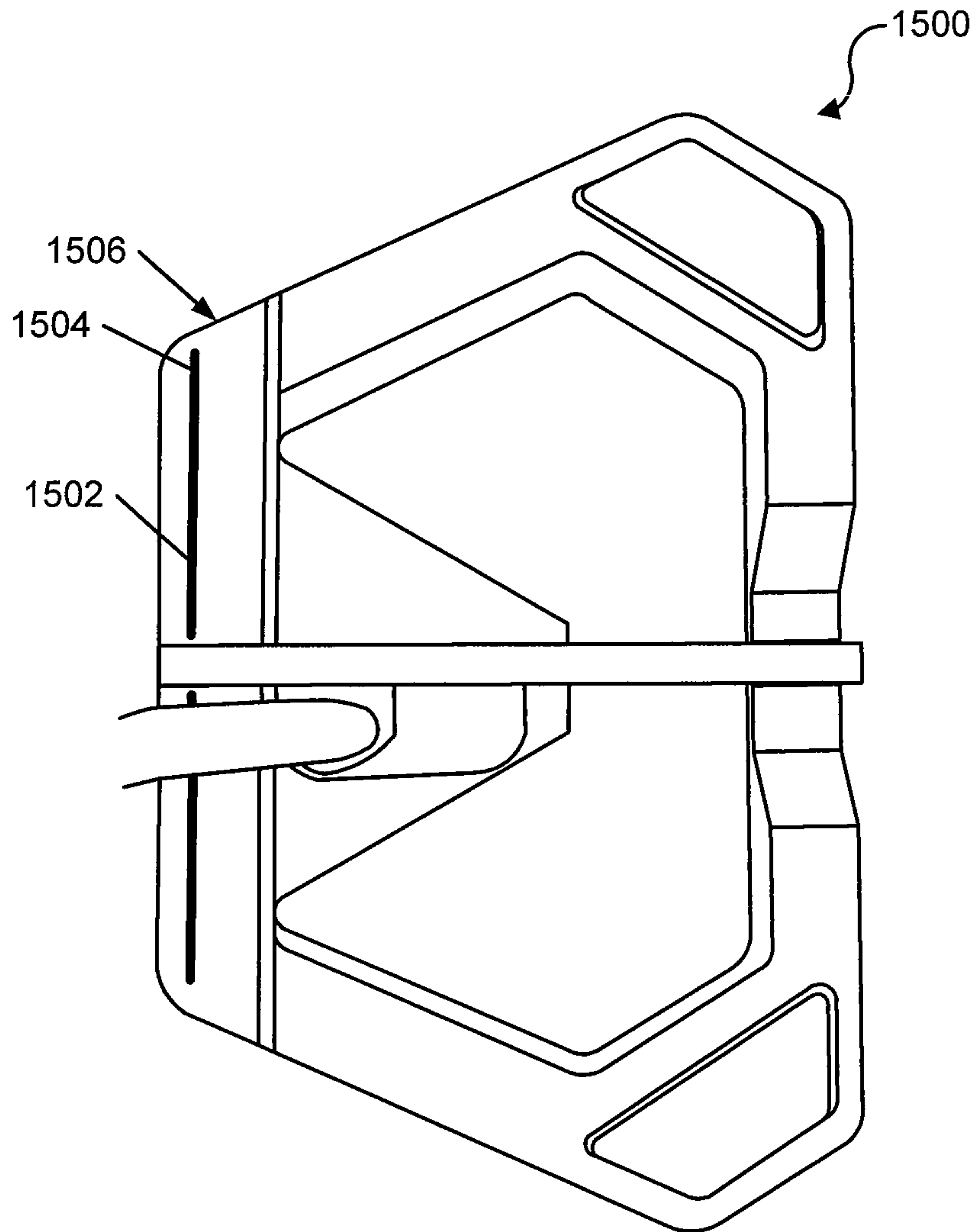

FIG. 15

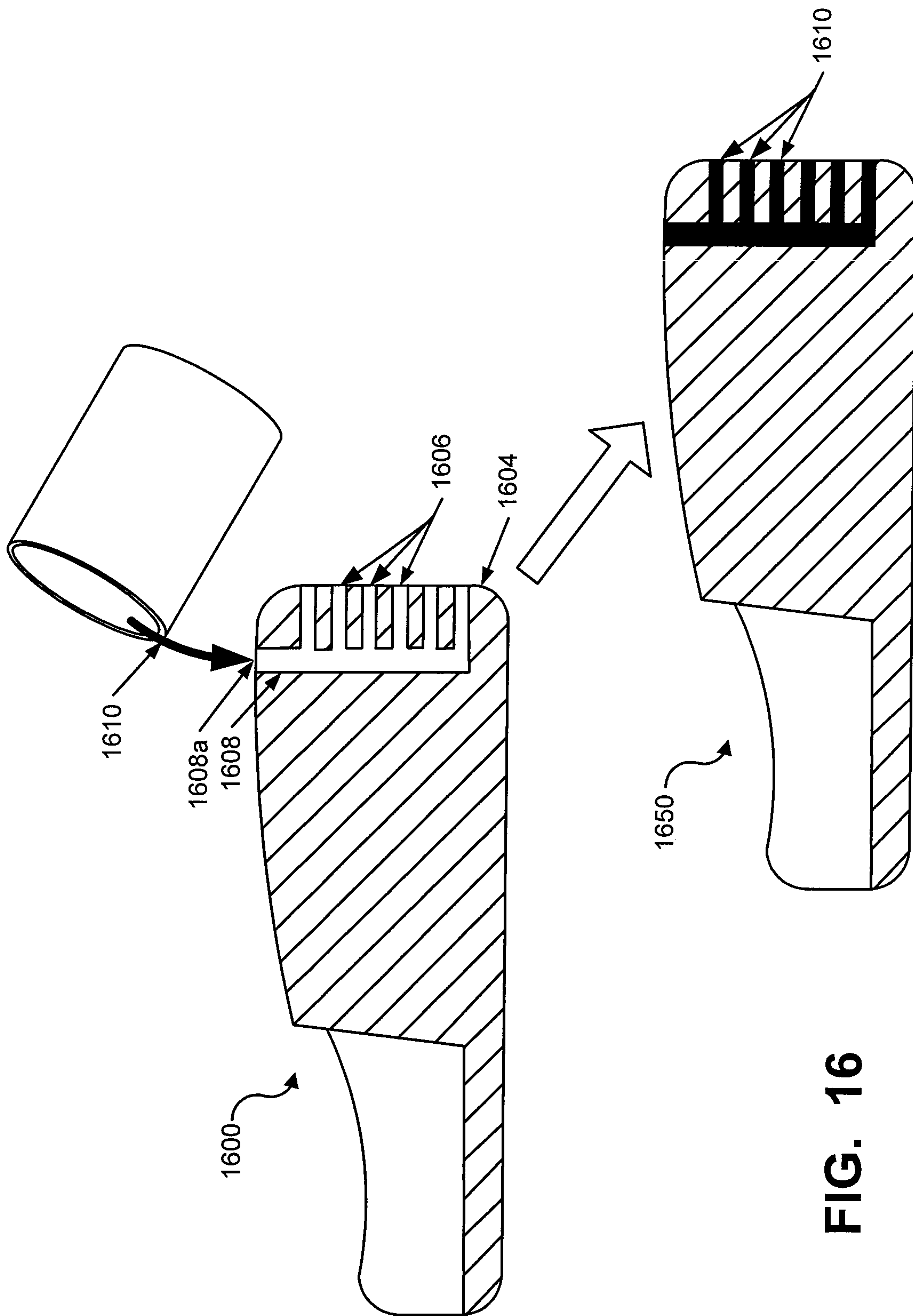

FIG. 16

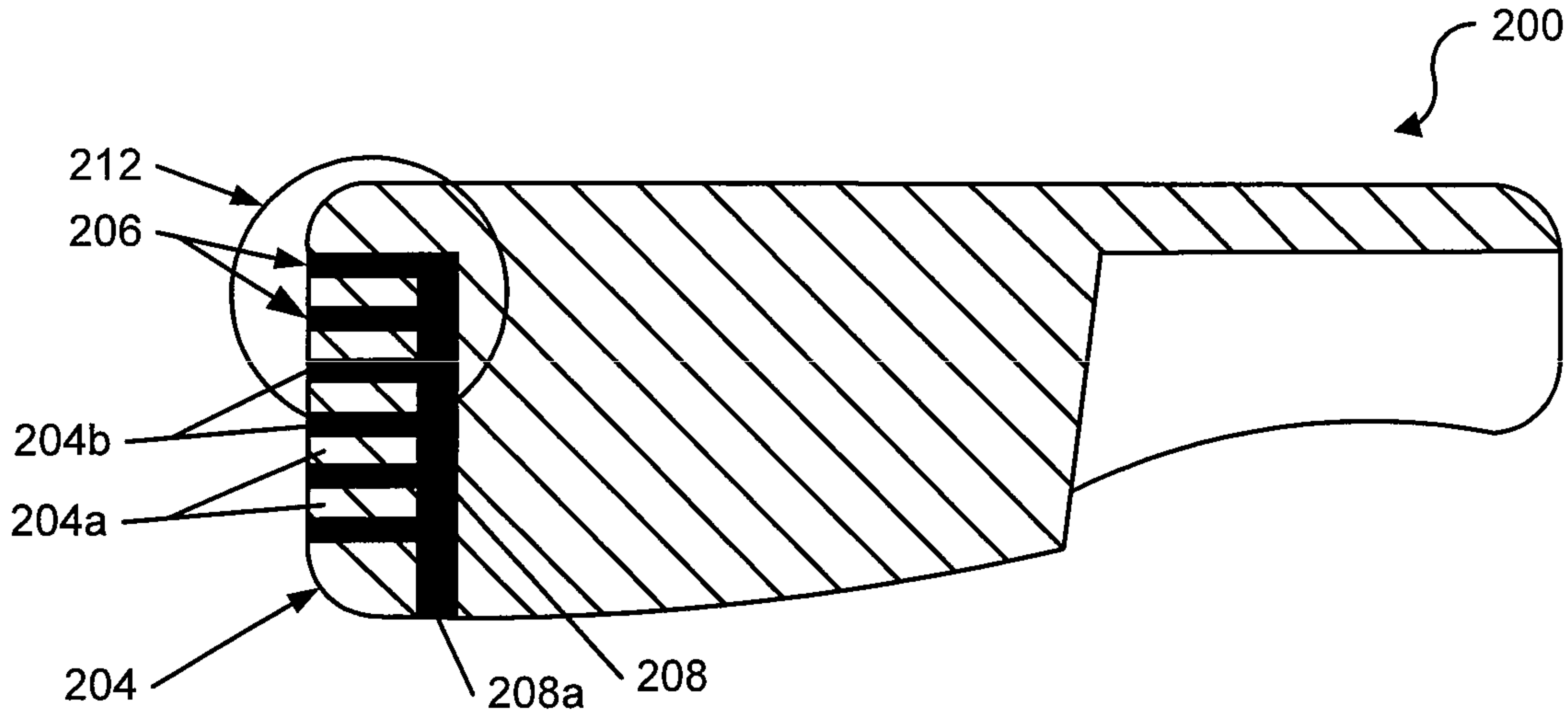

FIG. 2A