



Europäisches Patentamt  
European Patent Office  
Office européen des brevets



(11) **EP 1 375 169 A1**

(12) **EUROPEAN PATENT APPLICATION**

(43) Date of publication:  
**02.01.2004 Bulletin 2004/01**

(51) Int Cl.7: **B41J 19/78, B41J 2/21**

(21) Application number: **03076986.3**

(22) Date of filing: **23.06.2003**

(84) Designated Contracting States:  
**AT BE BG CH CY CZ DE DK EE ES FI FR GB GR  
HU IE IT LI LU MC NL PT RO SE SI SK TR**  
Designated Extension States:  
**AL LT LV MK**

(72) Inventor: **Faken, Henry  
5914 SH Venlo (NL)**

(74) Representative: **van Meeteren, Arend Anthonie  
Océ-Technologies B.V.,  
Corporate Patents,  
P.O. Box 101  
5900 MA Venlo (NL)**

(30) Priority: **26.06.2002 EP 02077774**

(71) Applicant: **Océ-Technologies B.V.  
5914 CC Venlo (NL)**

(54) **Printing device and control method thereof**

(57) A printing device comprising print heads having discharging elements arranged in (a) linear array(s) and a control method thereof is disclosed enabling to overcome or at least reduce the visibility to the human eye of systematic image dot-size variations, i.e. differences in dot-size of printed dots attributable to groups of discharging elements of print heads of the printing device. Therefore, on the basis of the dot-size differences of dots printed by different groups of discharging elements, the print heads and the image-receiving member displacement means are controlled such that in operation, for a given print mask, an optimal number of discharging elements is actually image-wise activated and an optimal displacement distance in the sub scanning direction is determined.

**FIG. 3B**

2	○	○	○	○
12	⊗	⊗	⊗	⊗
9	⊕	⊕	⊕	⊕
6	⊙	⊙	⊙	⊙
3	○	○	○	○
13	⊗	⊗	⊗	⊗
10	⊕	⊕	⊕	⊕
7	⊙	⊙	⊙	⊙
4	○	○	○	○
14	⊗	⊗	⊗	⊗
11	⊕	⊕	⊕	⊕
8	⊙	⊙	⊙	⊙
5	○	○	○	○
2	⊗	⊗	⊗	⊗
12	⊕	⊕	⊕	⊕
9	⊙	⊙	⊙	⊙
6	○	○	○	○
3	⊗	⊗	⊗	⊗
13	⊕	⊕	⊕	⊕
10	⊙	⊙	⊙	⊙
7	○	○	○	○
4	⊗	⊗	⊗	⊗
14	⊕	⊕	⊕	⊕
11	⊙	⊙	⊙	⊙
8	○	○	○	○
5	⊗	⊗	⊗	⊗
2	⊕	⊕	⊕	⊕

**EP 1 375 169 A1**

## Description

### FIELD OF THE INVENTION

**[0001]** The present invention is related to a printing device such as a printing or copying system employing print heads containing discharging elements, e.g. nozzles, for image-wise forming dots of a marking substance on an image-receiving member, where the marking substance is in fluid form when discharged. Examples of such printing devices are inkjet printers and toner-jet printers. Hereinafter reference will be made to inkjet printers.

### BACKGROUND OF THE INVENTION

**[0002]** Print heads employed in inkjet printers and the like usually each contain a plurality of nozzles arranged in (a) linear array(s) parallel to the propagation direction of the image-receiving member or in other words the sub scanning direction. The nozzles usually are placed substantially equidistant. The distance between two contiguous nozzles defines the nozzle pitch. In operation, the nozzles are controlled to image-wise discharge ink droplets on an image-receiving member such as to form columns of image dots of ink in relation to the linear arrays such that the printing pitch equals the nozzle pitch. In scanning inkjet printers, a matrix of image dots of ink, corresponding to a part of an image is subsequently formed by scanning the print heads across the image-receiving member, i.e. in the direction perpendicular to the propagation direction of the image-receiving member or in other words the main scanning direction. After a first matrix is completed the image-receiving member is displaced such as to enable the forming of the next matrix. This process may be repeated till the complete image is formed. An advantage of forming an image of image dots of ink on an image-receiving member as here described is the high productivity as only a single printing stage is employed. However, image quality may be improved by employing printing devices enabling the use of multiple printing stages. In the prior art two main categories of such printing devices can be distinguished, i.e. so-called "interlace systems" and "multi-pass systems".

**[0003]** In an interlace system, as e.g. disclosed in US 4,198,642, the print head contains N nozzles, which are arranged in (a) linear array(s) such that the nozzle pitch is an integer multiple of the printing pitch. Multiple printing stages, or so-called interlacing printing steps, are required to generate a complete image. According to this disclosure, the print head and the image-receiving member are controlled such that in I printing steps, I being defined here as the nozzle pitch divided by the printing pitch, a complete image part is formed on the image-receiving member. After each printing step, the image-receiving member is displaced over a distance of N times the printing pitch. Such a system is of particular

interest because it allows to achieve a higher print resolution with a limited nozzle resolution.

**[0004]** In a "multi-pass system", the print head contains N nozzles, which are arranged in (a) linear array (s). In operation, the print head is controlled such that only the nozzles corresponding to selected pixels of the image to be reproduced are image-wise activated. As a result an incomplete matrix of image dots is formed in a single printing stage, i.e. a horizontal scanning pass across the image-receiving member in one direction. Multiple passes are required to complete the matrix of image dots. In-between two passes the image-receiving member may be displaced in the sub scanning direction.

**[0005]** Both "interlace systems" and "multi-pass systems" as well as combinations thereof share the advantage of an improved image quality and the inherent disadvantage of a lower productivity. Such systems are known to be of particular interest to overcome or at least reduce the visibility of some banding artefacts, particularly regional banding artefacts. Regional banding artefacts are caused by irregularities which can be attributed to individual nozzles or small regional clusters of nozzles within the array(s). Such irregularities may lead to regional variations in dot-size or dot positioning. Examples of such irregularities are differences in nozzle shape or size, differences in the shape or size of the ducts connecting the ink reservoirs with the respective nozzles. These differences can occur in the manufacturing or may arise during use, e.g. caused by contamination of the ink. The so-called print mask contains the information about the number and sequence of printing stages and defines which nozzles need to be activated, or in other words contains the information defining for each printing stage which pixels will be rendered by which nozzles such that when all printing stages are completed, all the pixels are rendered. Prior art print masks are usually configured such as to minimise the influence of random regional variations in dot size and positioning. A print mask is associated with a printing mode. Selecting a printing mode enables the user to exchange image quality for productivity and vice versa dependent on his requirements. By selecting a printing mode also the nozzles on the print head which will be effectively used are determined as well as the displacement step in the sub scanning direction after each printing stage.

**[0006]** However besides banding artefacts caused by the above-described regional variations in dot-size or positioning, also very disturbing banding artefacts caused by so-called systematic variations in dot-size can arise in "interlace systems" and "multi-pass systems" as well as combinations thereof. Systematic dot-size variations are caused by differences in size of dots formed by different groups of nozzles. For instance, in a print head comprising two linear arrays of nozzles for the same colour, the first group of nozzles may constitute the first array of nozzles while the second group of nozzles constitutes the second array of nozzles. When

due to a small shift in the manufacturing process all nozzles of the first array are sized slightly different from the nozzles of the second array, systematic variations in dot-size can arise between droplets originating from nozzles of said first and second group. Another example is a print head comprising a single linear array of nozzles for a particular colour wherein the nozzles are controlled such that first the even nozzles within the array, i.e. the first group of nozzles, are discharged and thereafter the uneven nozzles within the array. Again this may lead to a systematic dot-size variation which in case of a thermal or thermal-assisted inkjet printer may be caused by e.g. a small temperature variation, or in case of a piezoelectrical inkjet printer may be caused by e.g. mechanically induced cross-talk. A further example is an inkjet printer comprising multiple print heads for a particular colour wherein the respective groups are constituted by the respective arrays of the respective print heads. In such a configuration, again e.g. small differences of nozzle sizes of nozzles groups each associated with a different print head may lead to systematic dot-size variations.

#### OBJECTS OF THE INVENTION

**[0007]** It is an object of the invention to control the print heads of "interlace systems" and "multi-pass systems" as well as combinations thereof such as to overcome or at least reduce the visibility of systematic image dot-size variations while limiting the influence on productivity.

**[0008]** It is another object of the invention to control the print head and the image-receiving member displacement means such that in operation for a given print mask an optimal number of nozzles is actually image-wise activated and an optimal displacement distance in the sub scanning direction is determined which limits the visibility of banding artefacts while maximising productivity.

#### SUMMARY OF THE INVENTION

**[0009]** In a first aspect of the invention, a printing device is disclosed comprising:

at least one print head for image-wise forming dots of a marking substance at a printing pitch,  $P$ , on an image-receiving member in relation to a pattern of image pixels, said print head comprising a plurality of  $N$  discharging elements being arranged in at least one linear array, being spaced at a predetermined element pitch, and being composed of at least a first group of discharging elements which, in operation, image-wise form dots of a marking substance of a first size and a second group of discharging elements which, in operation, image-wise form dots of a marking substance of a second size, different from said first size, on said image-receiving member,

displacement means for displacing said image-receiving member in the sub scanning direction; selecting means for selecting a print mask defining a number of  $S$  printing stages required to completely render said pattern of image pixels,  $S$  being an integer number of at least 2; control means for controlling said displacement means and for controlling said plurality of  $N$  discharging elements;

characterised in that

in operation, on the basis of the difference between said first size and said second size, said control means controls said displacement means such that said image-receiving member is displaced over a distance of  $M$  and controls said plurality of  $N$  discharging elements such that an effective number,  $N_{\text{eff}}$ , of discharging elements, is image-wise activated,  $N_{\text{eff}} \leq N$ . The printing device may further comprise scanning means for scanning the print heads in the main scanning direction.

The image-receiving member may be an intermediate member or a medium. The intermediate member may be an endless member, such as a belt or drum, which can be moved cyclically. The medium can be in web or sheet form and may be composed of e.g. paper, cardboard, label stock, plastic or textile.

**[0010]** Further according to the present invention, the respective groups of discharging elements forming image dots of different sizes may be part of a single linear array of discharge element of a single print head. The respective groups of discharging elements forming image dots of different sizes may be part of multiple linear arrays of discharging elements of a single print head, particularly the respective arrays may constitute the respective groups. The respective groups of discharging elements forming image dots of different sizes may be part of linear arrays of discharging elements of multiple print heads. The latter configuration is of particular interest when the multiple print heads form image dots of the same colour. In an embodiment of the invention, the print heads have a width, i.e. the maximal distance between discharge elements of a print head in the main scanning direction, equal to or larger than the width, i.e. the dimension in the main scanning direction, of the image-receiving member.

**[0011]** In another embodiment of the invention, the distance  $M$  and the effective number of discharging elements  $N_{\text{eff}}$  are determined, on the basis of the number of available discharging elements  $N$ , by combining at least the number of printing stages  $S$ , the number,  $q$ , of said groups of discharging elements, the printing pitch and the element pitch. Also the defect number,  $d$ , may be used to determine  $M$  and  $N_{\text{eff}}$ . The defect number,  $d$ , is defined as the number of subsequent printed image dots in the sub scanning direction originating from the same group of discharging elements when executing all the passes required to image-wise render all the pixels in the main scanning direction. Particularly, in case of

an "interlace system" a single scan is executed in the main scanning direction, while in case of a "multi-pass system" multiple scans are executed according to the print mask.

For instance, in case of a "multi-pass system", the distance  $M$  and the effective number of discharging elements  $N_{\text{eff}}$  can be obtained by satisfying the following conditions:

$$N_{\text{eff}} = S \times [(n \times q) + 1] \times d,$$

$$S \times M = N_{\text{eff}} \times p \times P,$$

and

$$p = 1,$$

wherein  $n$  is an integer greater than or equal to 1,

$p$  is the ratio between the element pitch and the printing pitch. Alternatively, in case of an "interlace system" or a combination of a "multi-pass system" and an "interlace system", the distance  $M$  and the effective number of discharging elements  $N_{\text{eff}}$  can be obtained by satisfying the following conditions:

$$p \times N_{\text{eff}} = S \times [(n \times q) + 1] \times (p \times d) + f],$$

and

$$S \times M = N_{\text{eff}} \times p \times P,$$

wherein  $n$  is an integer number greater than or equal to 1,

$p$ , the ratio between the element pitch and the printing pitch is an integer number of at least 2,

$f$  is a non-zero integer number defined as the minimal offset, expressed in number of positions in the print mask, between two subsequent printing stages. For instance, the print mask of fig. 2a defines a sequence 1,2,3,4,1,2,3,4,... therefore,  $f = \pm 1$ . A print mask defining a sequence 1, 4, 2, 5, 3, 1, 4, 2, 5, 3, ..., yields  $f = \pm 2$ ; a print mask defining a sequence 1,4,3,2,1,4,3,2, ..., yields  $f = -1$ .

**[0012]** In another aspect of the invention, a method is disclosed for image-wise forming dots of a marking substance at a printing pitch,  $P$ , on an image-receiving member in relation to a pattern of image pixels with a printing device comprising at least one print head, said print head comprising a plurality of  $N$  discharging elements being arranged in at least one linear array, being spaced at a predetermined element pitch, and being composed of at least a first group of discharging elements which, in operation, image-wise form dots of a

marking substance of a first size and a second group of discharging elements which, in operation, image-wise form dots of a marking substance of a second size, different from said first size, on said image-receiving member, said method comprising the steps of:

selecting a print mask defining a number,  $S$ , and sequence of printing stages required to completely render said pattern of image pixels,  $S$  being an integer number of at least 2;

image-wise activating on the basis of said print mask at least a part of an effective number,  $N_{\text{eff}}$ , of discharging elements,  $N_{\text{eff}} \leq N$  and intermittently displacing on the basis of said print mask said image-receiving member in the sub-scanning direction over a distance,  $M$ ;

characterised in that said distance,  $M$ , and said effective number,  $N_{\text{eff}}$ , of discharging elements are determined on the basis of the difference between said first size and said second size.

## BRIEF DESCRIPTION OF THE DRAWINGS

### **[0013]**

Figure 1 depicts an example of an inkjet printer.

Figure 2a depicts an example of a print mask.

Figure 2b depicts the image dots formed when activating the nozzles of a print head having a single linear array of 15 nozzles once.

Figure 2c depicts a part of a matrix of ink dots formed in relation to a pattern of image pixels using the same print head as used in figure 2b and the print mask of figure 2a.

Figure 3a depicts the image dots formed when activating the nozzles, selected according to an embodiment of the present invention, of the same print head as used in figure 2b once.

Figure 3b depicts a part of a matrix of ink dots formed in relation to a pattern of image pixels using the print mask of figure 2a, the nozzle selection as indicated in figure 2b and a displacement distance in the main scanning direction determined according to an embodiment of the present invention.

Figure 4 depicts the image dots formed when activating the nozzles of a print head having 99 nozzles arranged in two linear arrays once.

Figure 5 depicts the image dots formed when activating the nozzles of a print head having 99 nozzles arranged in two linear arrays once.

Figure 6a depicts an example of a print mask.

Figure 6b schematically depicts parts of a matrix of ink dots formed in relation to a pattern of image pixels using the print mask of figure 6a.

## DETAILED DESCRIPTION OF THE INVENTION

**[0014]** In relation to the appended drawings, the present invention is described in detail in the sequel. Several embodiments are disclosed. It is apparent however that a person skilled in the art can imagine several other equivalent embodiments or other ways of executing the present invention, the scope of the present invention being limited only by the terms of the appended claims.

**[0015]** The printing device of fig.1 is an inkjet printer comprising a roller (1) for supporting an image-receiving member (2) and moving it along four print heads (3), each of a different process colour. The roller is rotatable about its axis as indicated by arrow A. A scanning carriage (4) carries the four print heads and can be moved in reciprocation in the main scanning direction, i.e. the direction indicated by the double arrow B, parallel to the roller (1), such as to enable scanning of the image-receiving member in the main scanning direction. The image-receiving member can be a medium in web or in sheet form and may be composed of e.g. paper, cardboard, label stock, plastic or textile. Alternately, the image-receiving member can also be an intermediate member, endless or not. Examples of endless members, which can be moved cyclically, are a belt or a drum. The carriage (4) is guided on rods (5) (6) and is driven by suitable means (not shown). Each print head comprises a number of discharging elements (7) arranged in a single linear array parallel to the sub scanning direction. Four discharging elements per print head are depicted in the figure, however obviously in a practical embodiment typically several hundreds of discharging elements are provided per print head. Each discharge element is connected via an ink duct to an ink reservoir of the corresponding colour. Each ink duct is provided with means for activating the ink duct and an associated electrical drive circuit. For instance the ink duct may be activated thermally and/or piezoelectrically. When the ink duct is activated an ink drop is discharged from the discharge element in the direction of the roller (1) and forms a dot of ink on the image-receiving member.

**[0016]** To enable printing firstly a digital image is to be formed. There are numerous ways to generate a digital image. For instance, a digital image may be created by scanning an original using a scanner. Digital still images may also be created by a camera or a video camera. Besides digital images generated by a scanner or a camera, which are usually in a bitmap format or a compressed bitmap format also artificially created, e.g. by a computer program, digital images or documents may be offered to printing device. The latter images can be in a vector format. The latter images can also be in a structured format including but not limited to a page description language (PDL) format and an extensible markup language (XML) format. Examples of a PDL format are PDF (Adobe), PostScript (Adobe), and PCL (Hewlett-Packard). The image processing system typically con-

verts a digital image with known techniques into a series of bitmaps in the process colours of the printing device. Each bitmap is a raster representation of a separation image of a process colour specifying for each pixel ("picture element") an image density value for said process colour. The image density value is typically an 8-bit value which enables the use of 256 grey levels per process colour. These bitmaps are converted into a printable format by means of a halftoning technique. In case of binary halftoning, these 8-bit values are converted into a single-bit value specifying for each pixel whether or not an image dot of ink of the associated process colour is to be formed. The image processing system may be incorporated in a computer which can be coupled by a network or any other interface to one or more printing devices. The image processing system may also be part of the printing device.

By image-wise activating the ink ducts in relation to the pattern(s) of image pixels an image composed of ink dots can be formed on the image-receiving member.

Comparative example 1

**[0017]** A printing device as depicted in Figure 1 is used to reproduce a digital image. Instead of using the print heads each provided with four discharging elements as in the figure, each print head is provided with 15 discharging elements, i.e. nozzles, arranged in a single linear array. The nozzles are positioned equidistant at a resolution of 150 npi (nozzles per inch). This means that the nozzle pitch or element pitch, being the distance between the centres of two adjacent nozzles is about 169.3  $\mu\text{m}$ .

**[0018]** Suppose the user selects a particular printing mode enabling to reproduce a digital image at a printing resolution of 600 dpi (dots per inch) in both directions, or in other words, the printing pitch, i.e. the distance between the centres of two contiguous dots of ink both in the main scanning direction and in the sub scanning direction, is about 42.3  $\mu\text{m}$ . The print mode is such that all the available nozzles are selected. To enable rendering of an image with a resolution higher than the nozzle resolution, the print mask associated with the selected printing mode as in figure 2a defines an interlacing system. The print mask defines a sequence of four printing stages required to completely render the raster of image pixels. The sequence is such that during the first printing stage, labelled as 1 in fig. 2a, each selected nozzle of a print head renders all the associated pixels in the main scanning direction. In other words, each selected nozzle image-wise forms a complete line of image dots of ink in the main scanning direction. In the sub scanning direction only every fourth pixel is rendered during the first printing stage. After the first printing stage the image-receiving member is displaced over a distance M, being an integer multiple of the printing pitch which is about 42.3  $\mu\text{m}$ , such that in the second printing stage, labelled as 2 in fig.2a, pixel rows which are shifted one pixel with

respect to the pixel rows rendered in the first printing stage are rendered. In other words,  $M = [(4 \times m) \pm 1] \times$  printing pitch,  $m$  being an integer number. Again, in the second printing stage, each selected nozzle image-wise forms a complete line of image dots of ink in the main scanning direction while in the sub scanning direction only every fourth pixel is rendered being shifted one pixel compared to the first printing stage. After the second printing stage the image-receiving member is again displaced over the distance  $M$ , such that in the third printing stage, labelled as 3 in fig.2a, pixel rows which are shifted two pixels with respect to the pixel rows rendered in the first printing stage are rendered. In the third printing stage, each selected nozzle image-wise forms a complete line of image dots of ink in the main scanning direction while in the sub scanning direction only every fourth pixel is rendered being shifted two pixels compared to the first printing stage. After the third printing stage the image-receiving member is again displaced over the distance  $M$ , such that in the fourth printing stage, labelled as 4 in fig.2a, pixel rows, which are shifted three pixels with respect to the pixel rows rendered in the first printing stage, are rendered. In the fourth printing stage, each selected nozzle image-wise forms a complete line of image dots of ink in the main scanning direction while in the sub scanning direction only every fourth pixel is rendered being shifted three pixels compared to the first printing stage. After completing this fourth printing stage, at least a part of the raster of image pixels is completely rendered. By displacing the print head again over a distance  $M$  and repeating the sequence of printing stages as described above, the complete raster of image pixels can be rendered.

**[0019]** Further according to this comparative example, Fig.2c depicts a part of a matrix of ink dots formed in relation to a pattern of image pixels using the printing device of this comparative example and the print mask of Fig.2a. For instruction purposes, only the dots generated by a single print head are shown and a full coverage image is assumed. In practice however, it is clear that in the same way multi-colour images can be formed by adequately timing both the driving of the respective print heads and the image-wise activation of the associated nozzles. The nozzle pitch of about  $169.3 \mu\text{m}$  is indicated by the arrow D2. The printing pitch in the main scanning direction of  $42.3 \mu\text{m}$  is indicated by the arrow D3, while the printing pitch in the sub scanning direction of  $42.3 \mu\text{m}$  is indicated by the arrow D1. The distance  $M$  over which the print head is displaced after each printing stage is indicated by the arrow D4.  $M$  equals 15 times the printing pitch D1 and is chosen such as to minimise regional banding artefacts. The part of the matrix displayed in fig.2c contains an arbitrary subset of rows and columns of image dots formed by a single print head of a particular colour in relation to the associated part of the raster of image pixels of said colour. In the left column of the matrix, the nozzle number is indicated used to form the image dots of the associated row. As also

indicated in fig.2a, the dots formed during the first printing stage are represented by a blank circle, while for each of the other printing stages a representation with a specific fill pattern is chosen. As depicted in fig.2b, the 15 nozzles of the print head form image dots of ink of a different size on the image-receiving member. The image dots formed by the second group of nozzles, i.e. the even nozzles are smaller than the image dots formed by the first group of nozzles, i.e. the uneven nozzles. As a result of this group variation a systematic banding artefact is clearly visible in the sub scanning direction in fig. 2c. The banding artefact has a size of four times the print pitch.

#### 15 Example 1

**[0020]** When observing a systematic banding artefact on the image-receiving member caused by dot-size variation on a group level, as described in the comparative example 1, according to the present invention, on the basis of the dot-size differences, for a given printing mode and associated print mask, an effective number of discharging elements  $N_{\text{eff}}$ ,  $N_{\text{eff}} \leq N$ , and an optimum displacement distance,  $M$ , in the sub scanning direction is determined. Particularly, given that the print mask as depicted in fig.2a defines four printing stages,  $S$ , and that the ratio,  $p$ , between the element pitch and the printing pitch equals four, to at least reduce the visible effect of a banding artefact caused by systematic dot-size variation, the following conditions should be met:

$$p \times N_{\text{eff}} = S \times [(n \times q) + 1] \times (p \times d) + f,$$

35 and

$$S \times M = N_{\text{eff}} \times p \times P,$$

40 wherein  $n$  is an integer number greater than or equal to 1,

$$f = \pm 1,$$

45

$q$  is the number of groups of nozzles yielding image dots with different sizes; according to this example  $q$  equals 2 as there are two groups forming image dots of different size: the even nozzles and the uneven nozzles,

50

$d$ , the defect number, equals 1 according to this example as subsequent printed dots in the sub scanning direction, printed in a single scan in the main scanning direction, are alternately formed by an even and an uneven nozzle.

55

By consequence:  $N_{\text{eff}} = (8 \times n) + 4 \pm 1$  and  $M = N_{\text{eff}} \times P$ . Knowing that the print mode and the print head are such that maximal 15 nozzles can be selected, the most pro-

ductive mode yields  $N_{\text{eff}} = 13$ ,  $M = 13$  times the printing pitch. Therefore, in operation, the print head is controlled such that only 13 nozzles can be image-wise activated. As depicted in fig.3a, these 13 nozzles of the print head form image dots of ink of a different size on the image-receiving member. In the printing mode according to this example, the nozzles 1 and 15 can no longer be activated.

**[0021]** Fig.3b depicts a part of a matrix of ink dots formed in relation to the same pattern of image pixels as described in the comparative example 1. The same printing device of this comparative example and the print mask of Fig.2a are used, but the print head is controlled such that only thirteen nozzles, i.e. the nozzles 2 to 14, can be image-wise activated. As can be observed in the figure, after each of the four printing stages, the image-receiving member is displaced over a distance equal to 13 times the printing pitch. The systematic banding artefact with a size of four times the print pitch, as in fig. 2c, is less visible to the human eye due to the higher spatial frequency of the artefact. The image quality is clearly improved with a limited effect on productivity using the same print mask.

#### Example 2

**[0022]** A printing device as depicted in Figure 1 is used to reproduce a digital image. Instead of using the print heads each provided with four discharging elements as in the figure, each print head is provided with 99 discharging elements, i.e. nozzles, arranged in two staggered linear arrays. The nozzles are positioned equidistant at a resolution of 150 npi (nozzles per inch). This means that the nozzle pitch or element pitch, being the distance  $D_2$  of fig.4 between the centres of two adjacent nozzles is about 169.3  $\mu\text{m}$ . Analogous to example 1 and the comparative example 1, user selects a particular printing mode enabling to reproduce a digital image at a printing resolution of 600 dpi (dots per inch) in both directions using the same print mask as depicted in fig. 2a and previously described. The print mask as depicted in fig.2a defines four printing stages,  $S$ , and that the ratio,  $p$ , between the element pitch and the printing pitch equals four. When all the nozzles of the print head are activated once, an image dot pattern as indicated in Fig. 4 is formed on the image-receiving member. The dot-size of the image dots generated by the nozzles of the left array is different from the dot-size of the image dots generated by the nozzles of the right array. As this dot-size difference may result in a systematic banding artefact, according to the present invention an optimal effective number of nozzles,  $N_{\text{eff}}$ , as well as an optimal image-receiving member displacement distance,  $M$ , is determined such that the following conditions are satisfied:

$$p \times N_{\text{eff}} = S \times [(n \times q) + 1] \times (p \times d) + f, \text{ and}$$

$$S \times M = N_{\text{eff}} \times p \times P,$$

wherein  $n$  is an integer number greater than or equal to 1,

$$f = \pm 1,$$

$q$  is the number of groups of nozzles yielding image dots with different sizes; according to this example  $q$  equals 2 as there are two groups of nozzles forming image dots of different size: the nozzles of the left array and the nozzles of the right array,

$d$ , the defect number, equals 1 according to this example as subsequent printed dots in the sub scanning direction, printed in a single scan in the main scanning direction, are alternately formed by a nozzle of the left array and a nozzle of the right array.

By consequence:  $N_{\text{eff}} = (8 \times n) + 4 \pm 1$  and  $M = N_{\text{eff}} \times P$ .

**[0023]** Knowing that the print mode and the print head are such that maximal 99 nozzles can be selected, the most productive mode which reduces the visible effect of the banding artefact caused by the described systematic dot-size variation, yields  $N_{\text{eff}} = 99$ ,  $M = 99$  times the printing pitch.

#### Example 3

**[0024]** The same configuration is used as in example 2, except that when all the nozzles of a print head are activated once, an image dot pattern as indicated in Fig. 5 is formed on the image-receiving member. The dot-size of the image dots generated by the even nozzles within an array is different from the dot-size of the image dots generated by the uneven nozzles within an array. As this dot-size difference may result in a systematic banding artefact, according to the present invention an optimal effective number of nozzles,  $N_{\text{eff}}$ , as well as an optimal image-receiving member displacement distance,  $M$ , is determined such that the following conditions are satisfied:

$$p \times N_{\text{eff}} = S \times [(n \times q) + 1] \times (p \times d) + f,$$

and

$$S \times M = N_{\text{eff}} \times p \times P,$$

wherein  $n$  is an integer number greater than or equal to 1,

$$f = \pm 1,$$

$q$  is the number of groups of nozzles yielding im-

age dots with different sizes; according to this example  $q$  equals 2 as there are two groups of nozzles forming image dots of different size: the even nozzles of the respective arrays and the uneven nozzles of the respective arrays,

$d$ , the defect number, equals 2 according to this example as subsequent printed dots in the sub scanning direction, printed in a single scan in the main scanning direction, are alternately formed by even nozzles of the respective arrays and uneven nozzles of the respective arrays.

By consequence:  $N_{\text{eff}} = (16 \times n) + 8 \pm 1$  and  $M = N_{\text{eff}} \times P$ . Knowing that the print mode and the print head are such that maximal 99 nozzles can be selected, the most productive mode which reduces the visible effect of the banding artefact caused by the described systematic dot-size variation, yields  $N_{\text{eff}} = 89$ ,  $M = 89$  times the printing pitch.

#### Example 4

**[0025]** A printing device as depicted in Figure 1 is used to reproduce a digital image. Instead of using the print heads each provided with four discharging elements as in the figure, each print head is provided with 99 discharging elements, i.e. nozzles, arranged in a single linear array. The nozzles are positioned equidistant at a resolution of 600 npi (nozzles per inch). A particular printing mode is selected by the user enabling to reproduce a digital image at a printing resolution of 600 dpi (dots per inch) in both directions using the print mask as depicted in fig. 6a. The print mask as depicted in fig. 6a defines a "multi-pass" system with two printing stages,  $S$ , as depicted in fig. 6b. As the element pitch equals the printing pitch,  $p=1$ . Suppose the dot-size of the image dots formed by the even nozzles of the array is different from the dot-size of the image dots formed by the uneven dots of the array. Then, according an embodiment of this invention, to avoid or at least limit the visible effect of the associated systematic banding artefact, an effective number of nozzles is determined and controlled such that only these nozzles are selectable and can be image-wise activated. Particularly,  $N_{\text{eff}}$  and  $M$  are chosen such as to satisfy the following conditions:

$$N_{\text{eff}} = S \times [(n \times q) + 1] \times d,$$

and

$$S \times M = N_{\text{eff}} \times p \times P$$

wherein  $n$  is an integer number greater than or equal to 1,

$q$  is the number of groups of nozzles yielding image dots with different sizes; according to this example  $q$  equals 2 as there are two groups of nozzles forming

image dots of different size: the even nozzles of the array and the uneven nozzles of the array,

$d$ , the defect number, equals 1 according to this example as subsequent printed dots in the sub scanning direction after two scans in the main scanning direction are alternately formed by an even and an uneven nozzle.

By consequence:  $N_{\text{eff}} = (4 \times n) + 2$  and  $M = N_{\text{eff}} \times P/2$ . Knowing that the print mode and the print head are such that maximal 99 nozzles can be selected, the most productive mode which reduces the visible effect of the banding artefact caused by the described systematic dot-size variation, yields  $N_{\text{eff}} = 98$ ,  $M = 49$  times the printing pitch.

#### Claims

1. A printing device comprising:

at least one print head for image-wise forming dots of a marking substance at a printing pitch,  $P$ , on an image-receiving member in relation to a pattern of image pixels, said print head comprising a plurality of  $N$  discharging elements being arranged in at least one linear array, being spaced at a predetermined element pitch, and being composed of at least a first group of discharging elements which, in operation, image-wise form dots of a marking substance of a first size and a second group of discharging elements which, in operation, image-wise form dots of a marking substance of a second size, different from said first size, on said image-receiving member, displacement means for displacing said image-receiving member in the sub scanning direction; selecting means for selecting a print mask defining a number of  $S$  printing stages required to completely render said pattern of image pixels,  $S$  being an integer number of at least 2; control means for controlling said displacement means and for controlling said plurality of  $N$  discharging elements;

#### characterised in that

in operation, to limit the visibility of systematic banding artefacts in the sub scanning direction, on the basis of the difference between said first size and said second size, said control means controls said displacement means such that said image receiving member is displaced over a distance of  $M$  and selects an effective number,  $N_{\text{eff}}$ , of discharging elements,  $N_{\text{eff}}$ , of said plurality of  $N$  discharging elements for image-wise activation,  $N_{\text{eff}} \leq N$ .

2. The printing device as recited in claim 1, wherein,



on the basis of the number of available discharging elements N, said distance M and said effective number of discharging elements  $N_{\text{eff}}$  are determined by combining at least said number of printing stages S, the number, q, of said groups of discharging elements, the printing pitch and the element pitch.

3. The printing device as recited in claim 1 and 2, wherein the following conditions are satisfied:

$$N_{\text{eff}} = S \times [(n \times q) + 1] \times d,$$

$$S \times M = N_{\text{eff}} \times p \times P,$$

and

$$p = 1,$$

wherein n is an integer greater than or equal to 1,  
p is the ratio between the element pitch and the printing pitch,

d, the defect number, is defined as the number of subsequent printed image dots in the sub scanning direction originating from the same group of discharging elements when executing all the passes required to image-wise render all the pixels in the main scanning direction.

4. The printing device as recited in claim 3, further comprising scanning means for scanning said print head in the main scanning direction.
5. The printing device as recited in claim 1 and 2, wherein the ratio between the element pitch and the printing pitch is an integer number, p, of at least 2.
6. The printing device as recited in claim 5, wherein the following conditions are satisfied:

$$p \times N_{\text{eff}} = S \times (((n \times q) + 1) \times (p \times d) + f),$$

and

$$S \times M = N_{\text{eff}} \times p \times P,$$

wherein n is an integer number greater than or equal to 1,

f is a non-zero integer number defined as the minimal offset, expressed in number of positions in the print mask, between two subsequent printing stages,

d, the defect number, is defined as the number

of subsequent printed image dots in the sub scanning direction originating from the same group of discharging elements when executing all the passes required to render all the pixels in the main scanning direction.

7. The printing device as recited in claim 6, said print head has a width equal to or larger than the width of the image-receiving member.

8. The printing device as recited in claim 1 and 2, wherein said print head comprises a plurality of N discharging elements arranged in at least a first and a second linear array.

9. The printing device as recited in claim 8, wherein said first linear array is composed of said first group of discharging elements and said second linear array is composed of said second group of discharging elements.

10. The printing device as recited in claim 1 and 2, comprising a first print head of a colour and at least a second print head of said colour, which together comprise a plurality of N discharging elements being arranged in at least one linear array on said first print head and at least one linear array on said second print head.

11. The printing device as recited in claim 10, wherein the discharging elements of said first print head form said first group and the discharging elements of said second print head form said second group.

12. A method for image-wise forming dots of a marking substance at a printing pitch, P, on an image-receiving member in relation to a pattern of image pixels with a printing device comprising at least one print head, said print head comprising a plurality of N discharging elements being arranged in at least one linear array, being spaced at a predetermined element pitch, and being composed of at least a first group of discharging elements which, in operation, image-wise form dots of a marking substance of a first size and a second group of discharging elements which, in operation, image-wise form dots of a marking substance of a second size, different from said first size, on said image-receiving member, said method comprising the steps of:

selecting a print mask defining a number, S, and sequence of printing stages required to completely render said pattern of image pixels, S being an integer number of at least 2;  
image-wise activating on the basis of said print mask at least a part of an effective number of discharging elements,  $N_{\text{eff}}$ ,  $N_{\text{eff}} \leq N$ ; and  
intermittently displacing on the basis of said

print mask said image-receiving member in the sub-scanning direction over a distance, M;

**characterised in that**

said distance, M, is determined and said effective number of discharging elements,  $N_{eff}$ , is selected from said plurality of N discharging elements on the basis of the difference between said first size and said second size in order to limit the visibility of systematic banding artefacts in the sub scanning direction.

13. The method as recited in claim 12, wherein said distance M and said effective number of discharging elements,  $N_{eff}$ , are determined by combining at least said number of printing stages S, the number, q, of said groups of discharging elements, the printing pitch and the element pitch.

5

10

15

20

25

30

35

40

45

50

55

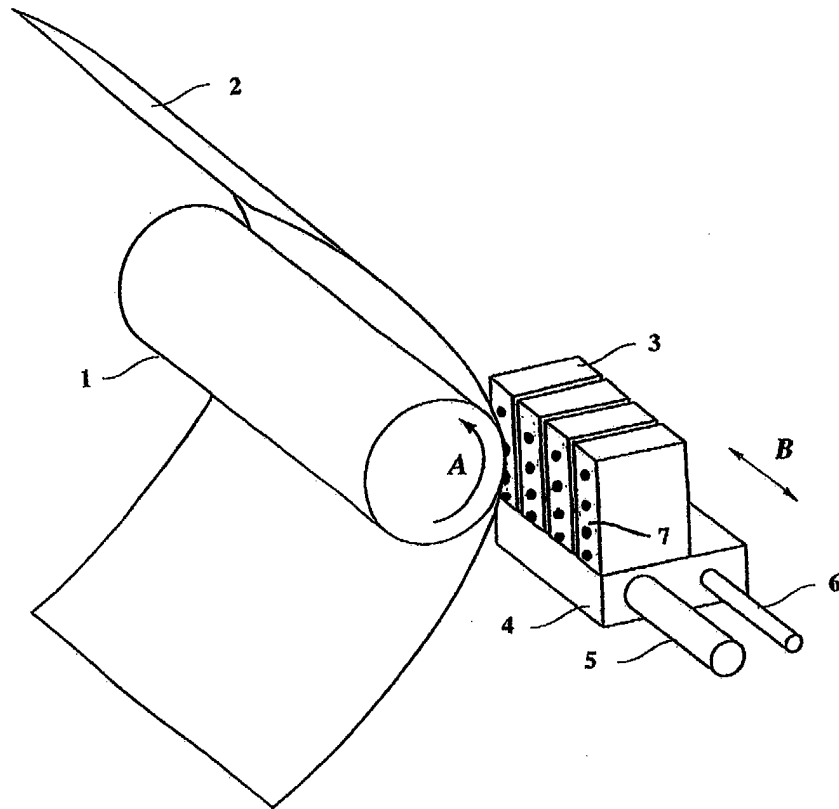

FIG. 1

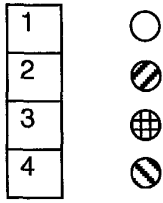

FIG. 2A

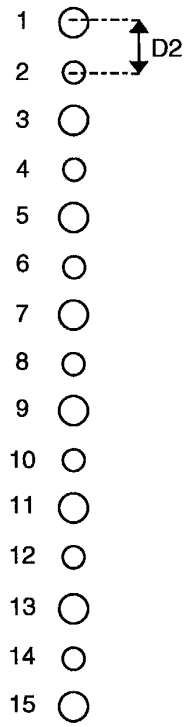

FIG. 2B

FIG. 2C

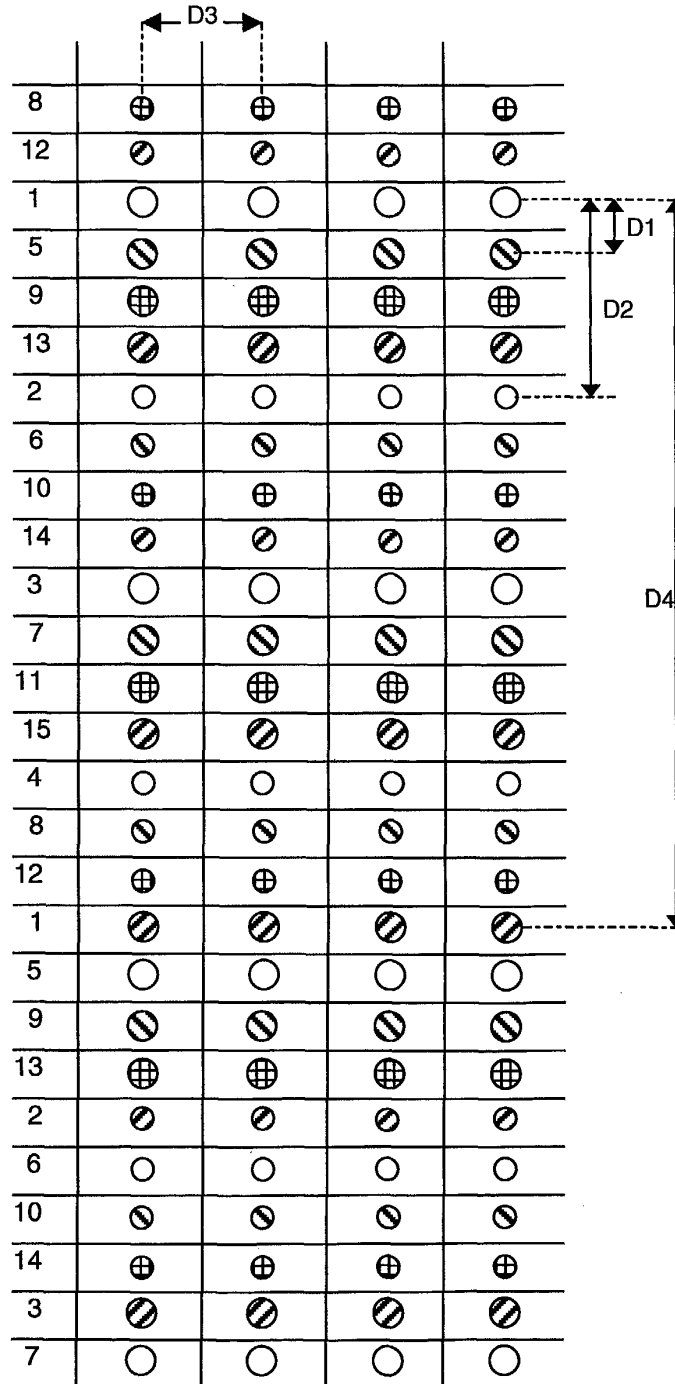

FIG. 3A















- 1 
- 2 
- 3 
- 4 
- 5 
- 6 
- 7 
- 8 
- 9 
- 10 
- 11 
- 12 
- 13 
- 14 
- 15 

FIG. 3B













































































































2				
12				
9				
6				
3				
13				
10				
7				
4				
14				
11				
8				
5				
2				
12				
9				
6				
3				
13				
10				
7				
4				
14				
11				
8				
5				
2				

FIG. 4

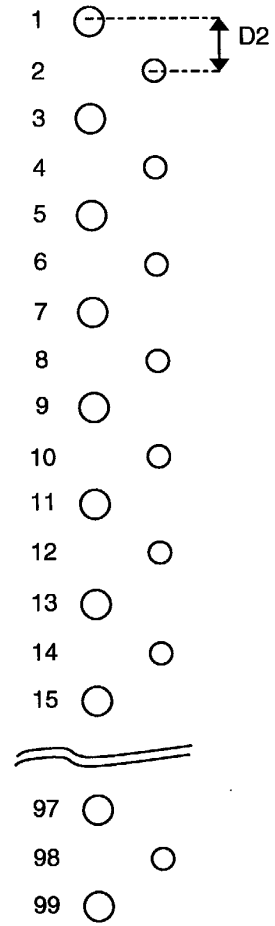

FIG. 5

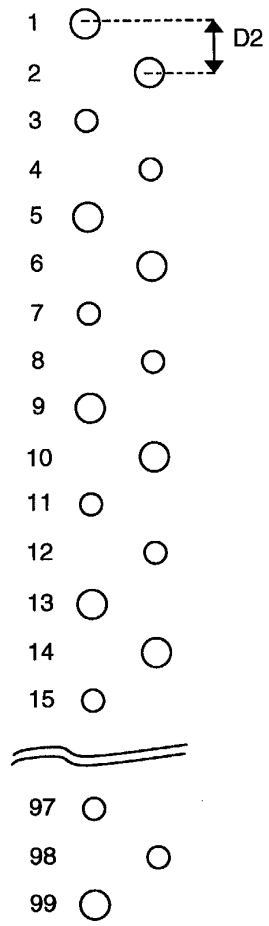
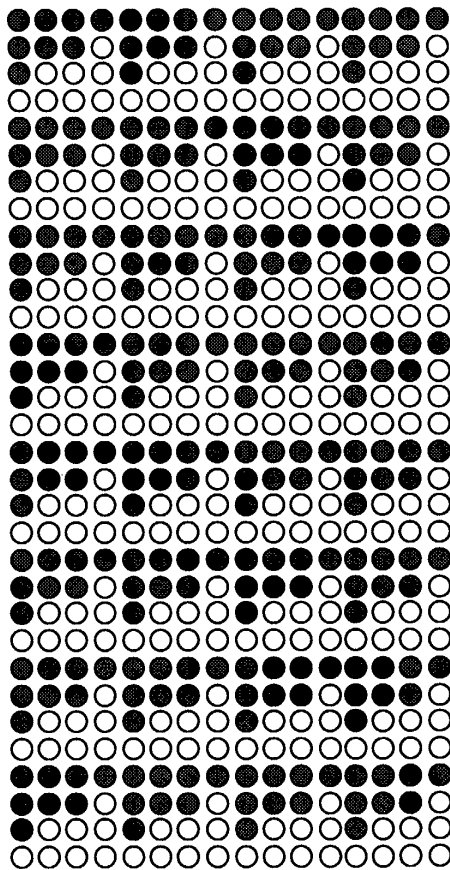

FIG. 6A

1	1	1	1
1	1	1	2
1	2	2	2
2	2	2	2

FIG. 6B



first printing stage

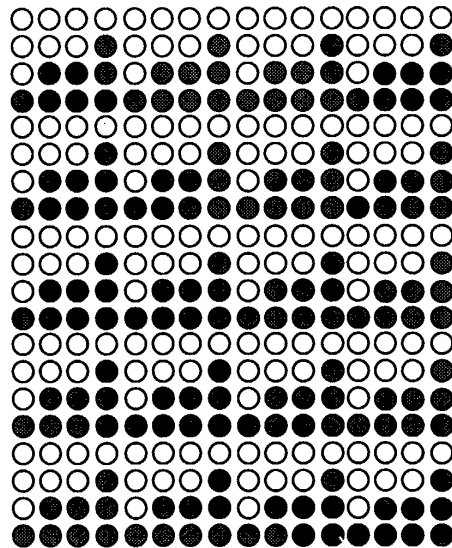

second printing stage





European Patent  
Office

## EUROPEAN SEARCH REPORT

Application Number  
EP 03 07 6986

DOCUMENTS CONSIDERED TO BE RELEVANT			
Category	Citation of document with indication, where appropriate, of relevant passages	Relevant to claim	CLASSIFICATION OF THE APPLICATION (Int.Cl.7)
X	EP 1 120 269 A (CANON KK) 1 August 2001 (2001-08-01) * paragraphs [0058], [0059], [0116] - [0124]; figures *	1,2,5, 12,13	B41J19/78 B41J2/21
A	--- EP 0 931 664 A (SEIKO EPSON CORP) 28 July 1999 (1999-07-28) * paragraphs [0054], [0064] - [0080] * * figures *	1,8-12	
A	--- EP 1 129 852 A (SEIKO EPSON CORP) 5 September 2001 (2001-09-05) * the whole document *	1,12	
			TECHNICAL FIELDS SEARCHED (Int.Cl.7)
			B41J
The present search report has been drawn up for all claims			
Place of search		Date of completion of the search	Examiner
THE HAGUE		20 October 2003	Didenot, B
CATEGORY OF CITED DOCUMENTS			
X : particularly relevant if taken alone Y : particularly relevant if combined with another document of the same category A : technological background O : non-written disclosure P : intermediate document		T : theory or principle underlying the invention E : earlier patent document, but published on, or after the filing date D : document cited in the application L : document cited for other reasons ..... & : member of the same patent family, corresponding document	

EPO FORM 1503 03.02 (P04/C01)

ANNEX TO THE EUROPEAN SEARCH REPORT  
ON EUROPEAN PATENT APPLICATION NO.

EP 03 07 6986

This annex lists the patent family members relating to the patent documents cited in the above-mentioned European search report. The members are as contained in the European Patent Office EDP file on  
The European Patent Office is in no way liable for these particulars which are merely given for the purpose of information.

20-10-2003

Patent document cited in search report	Publication date	Patent family member(s)	Publication date
EP 1120269 A	01-08-2001	JP 2001205828 A	31-07-2001
		EP 1120269 A1	01-08-2001
		US 2001026723 A1	04-10-2001
-----			
EP 0931664 A	28-07-1999	JP 11208029 A	03-08-1999
		EP 0931664 A2	28-07-1999
-----			
EP 1129852 A	05-09-2001	JP 2001121688 A	08-05-2001
		EP 1129852 A1	05-09-2001
		US 6435651 B1	20-08-2002
		WO 0112441 A1	22-02-2001
-----			

EPO FORM P0459

For more details about this annex : see Official Journal of the European Patent Office, No. 12/82