



US 20060248698A1

(19) **United States**

(12) **Patent Application Publication**

**Hanson et al.**

(10) **Pub. No.: US 2006/0248698 A1**

(43) **Pub. Date: Nov. 9, 2006**

(54) **TUBULAR STENT AND METHODS OF MAKING THE SAME**

**Publication Classification**

(76) Inventors: **Brian J. Hanson**, Little Canada, MN (US); **Wade M. Johnson**, Minneapolis, MN (US); **Kenneth M. Merdan**, Greenfield, MN (US)

(51) **Int. Cl.**  
*B21D 39/04* (2006.01)  
(52) **U.S. Cl.** ..... 29/282

Correspondence Address:  
**CROMPTON, SEAGER & TUFTE, LLC**  
1221 NICOLLET AVENUE  
SUITE 800  
MINNEAPOLIS, MN 55403-2420 (US)

(57) **ABSTRACT**

A stent and a method of making a stent from a tubular member. The stent includes a pattern and an opening cut into the wall of the stent and extending from the first end to the second end. One or more connectors may be cut in the tubular wall and extend into the opening cut in the tubular member. The connectors may aid in subsequent expansion and/or forming of the stent.

(21) Appl. No.: 11/122,397

(22) Filed: May 5, 2005

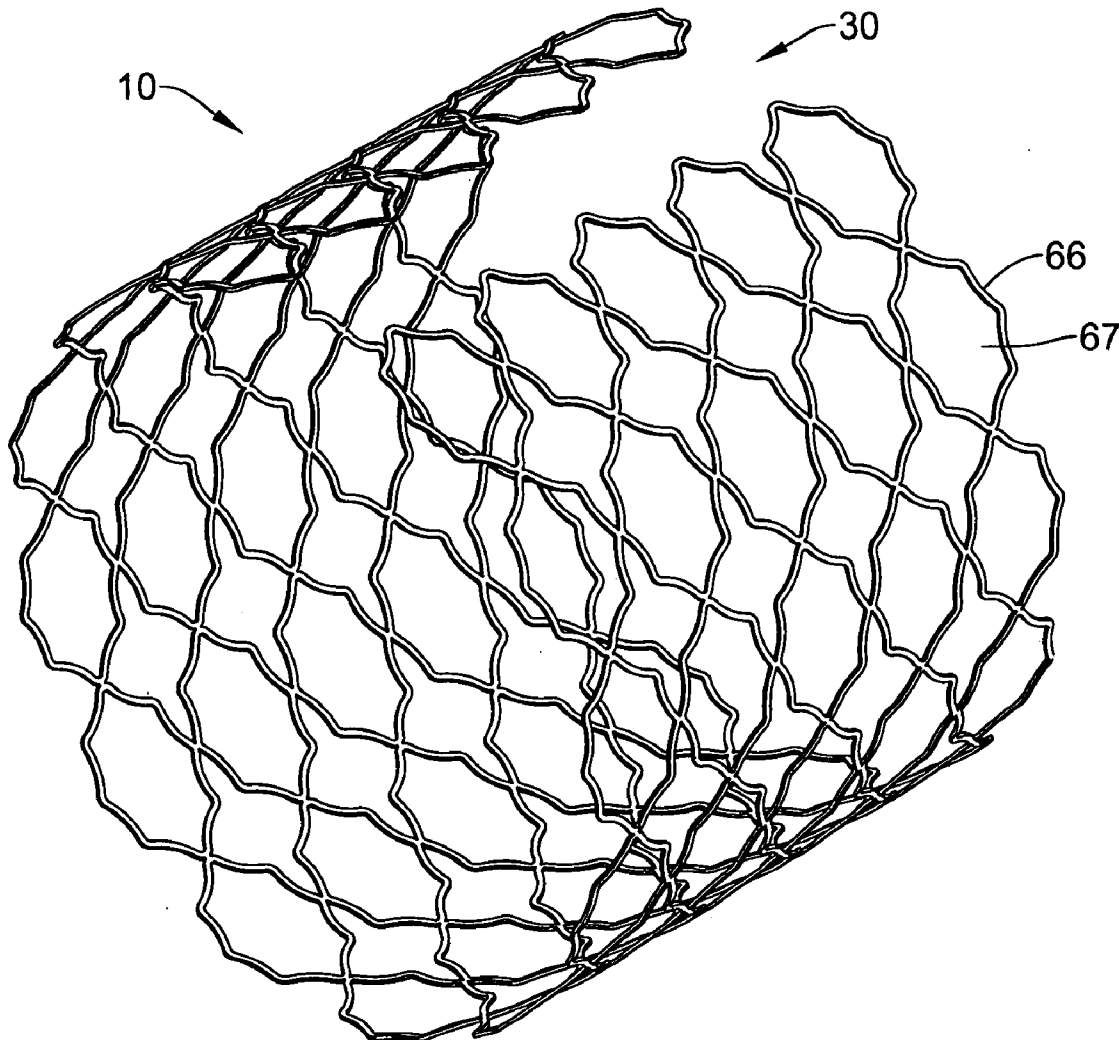

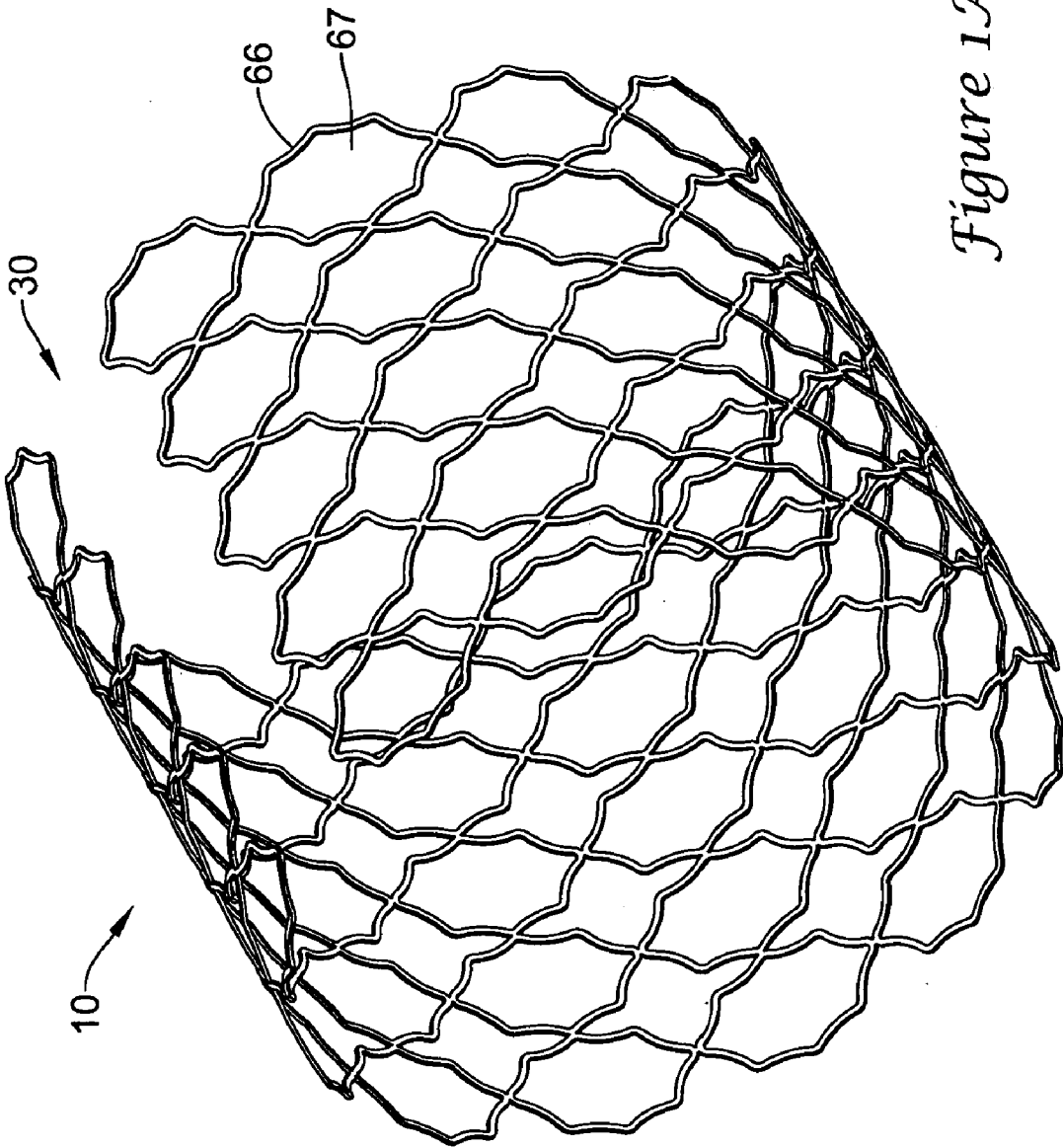

Figure 1A

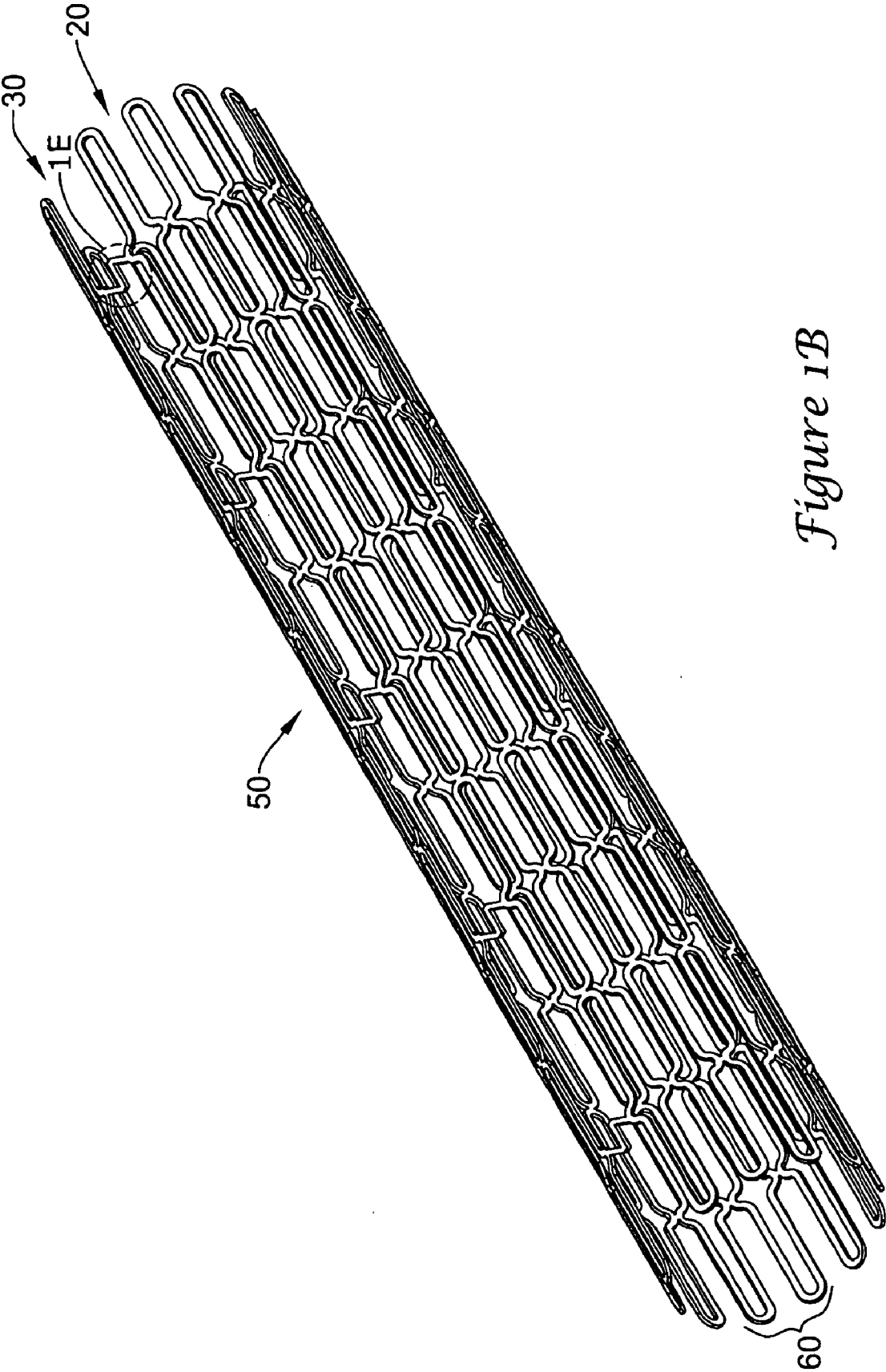

Figure 1B

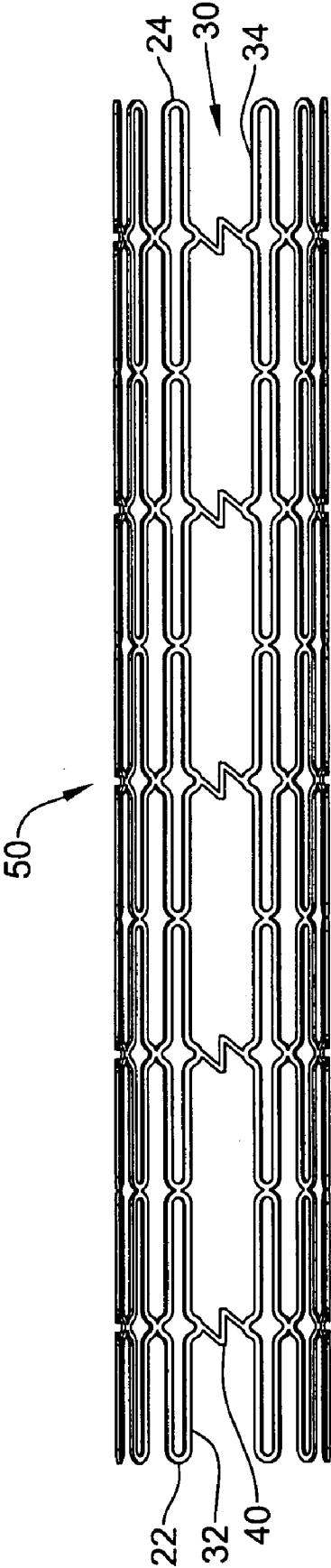

Figure 1C

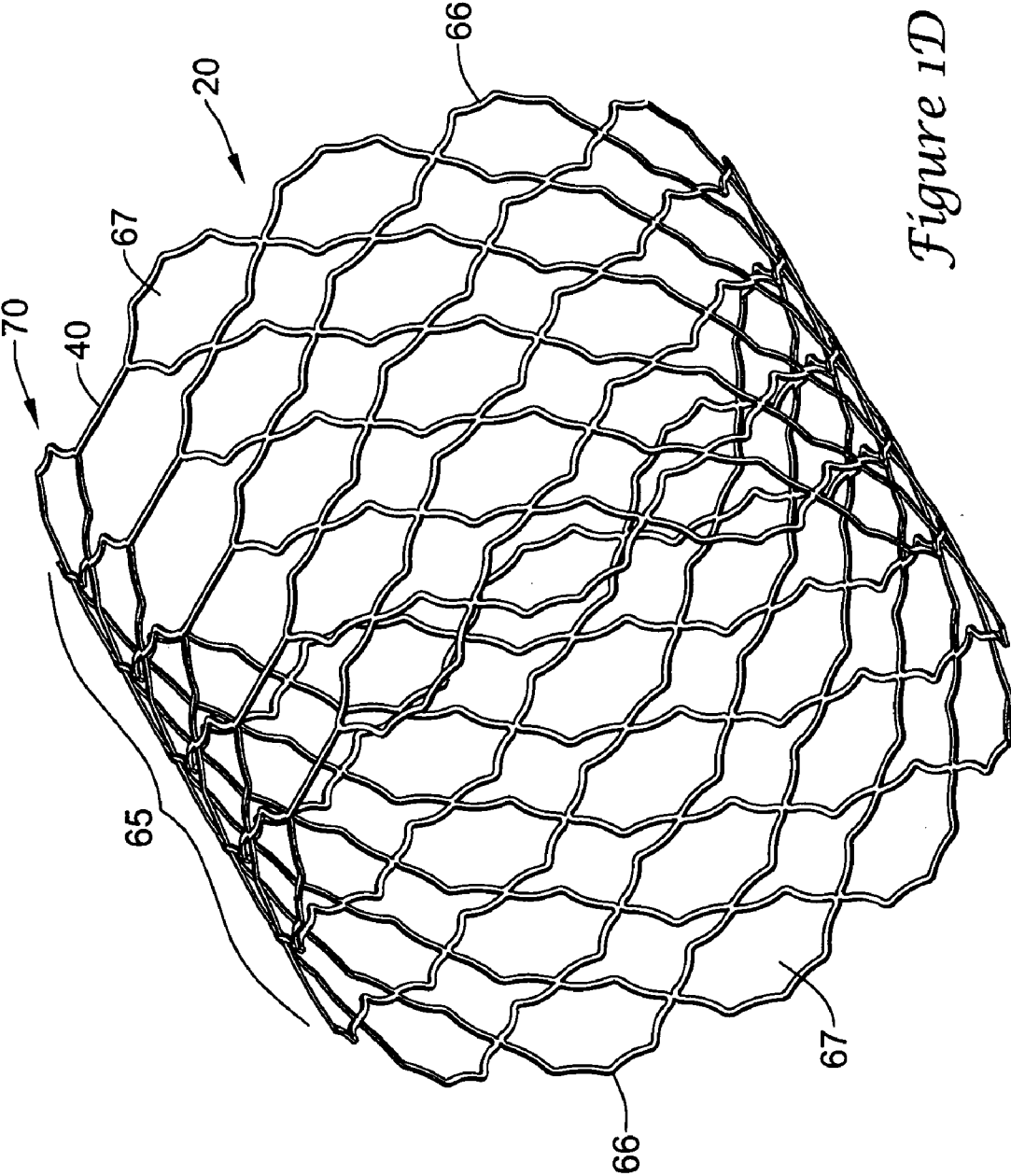
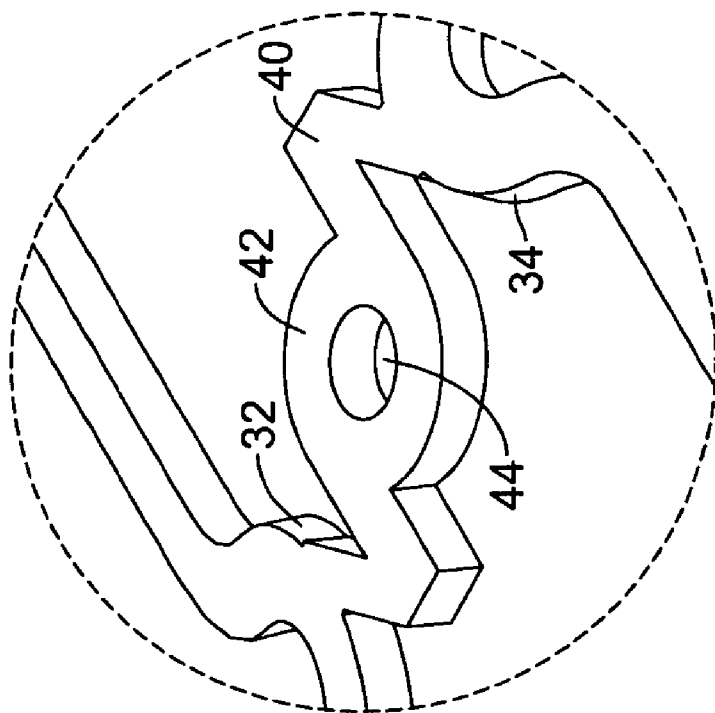
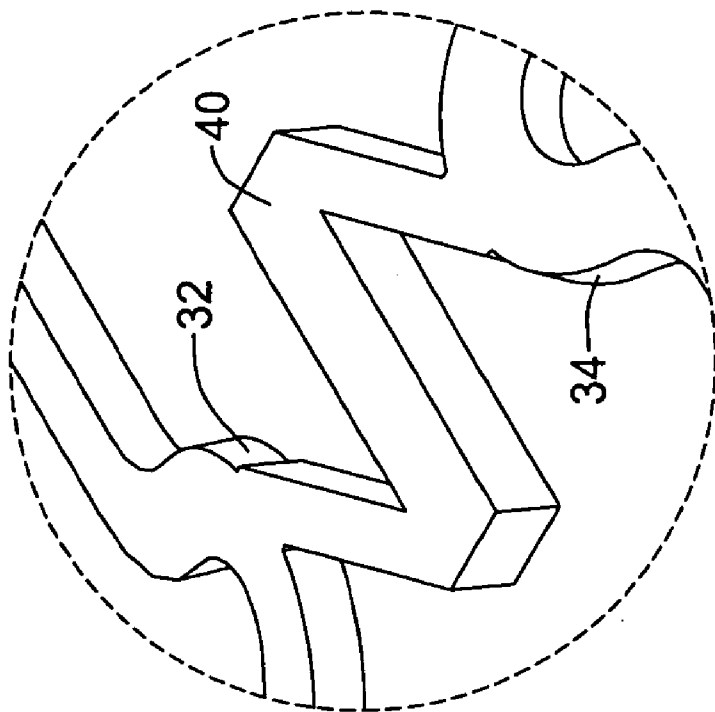

Figure 1D



*Figure 1F*



*Figure 1E*

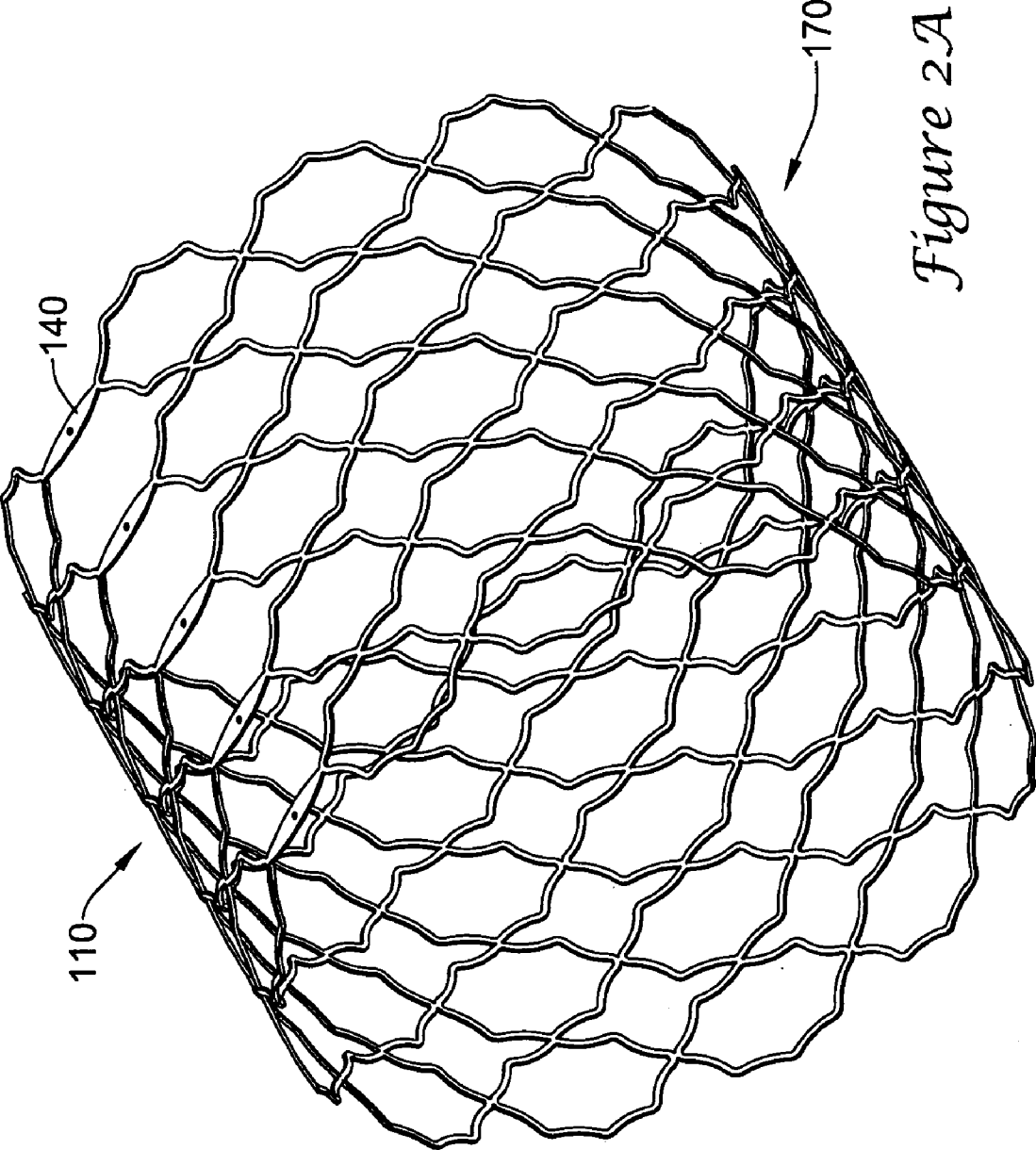

Figure 2A

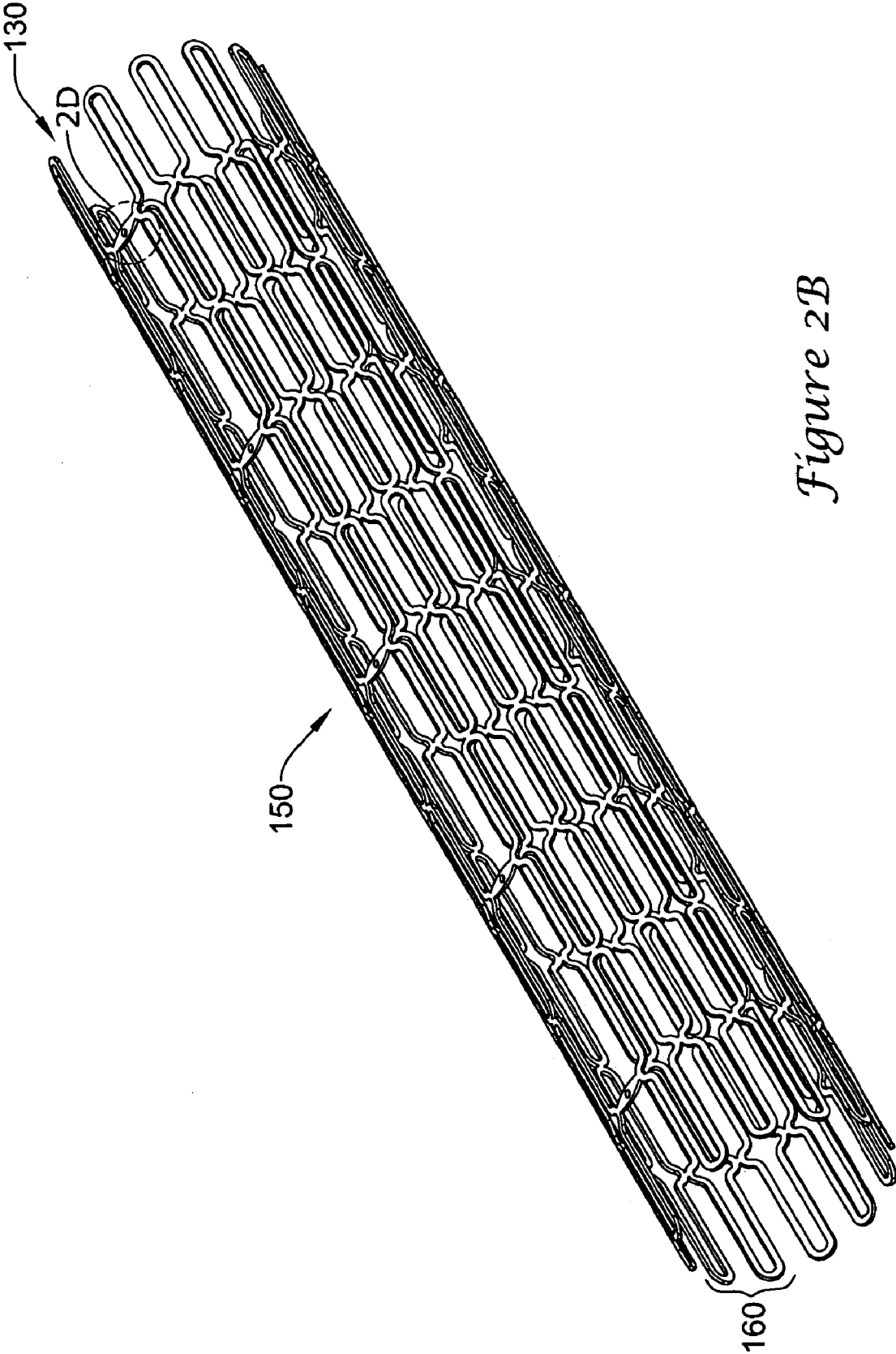

Figure 2B



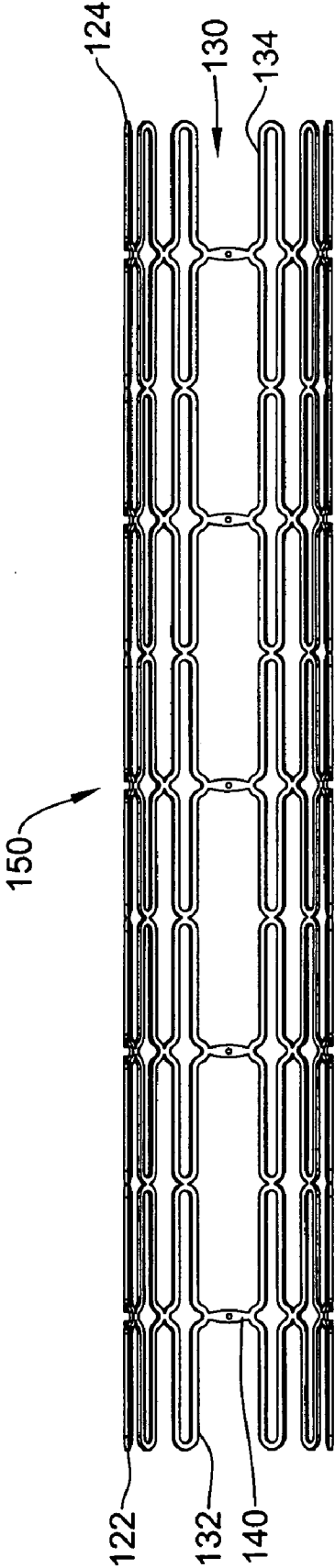
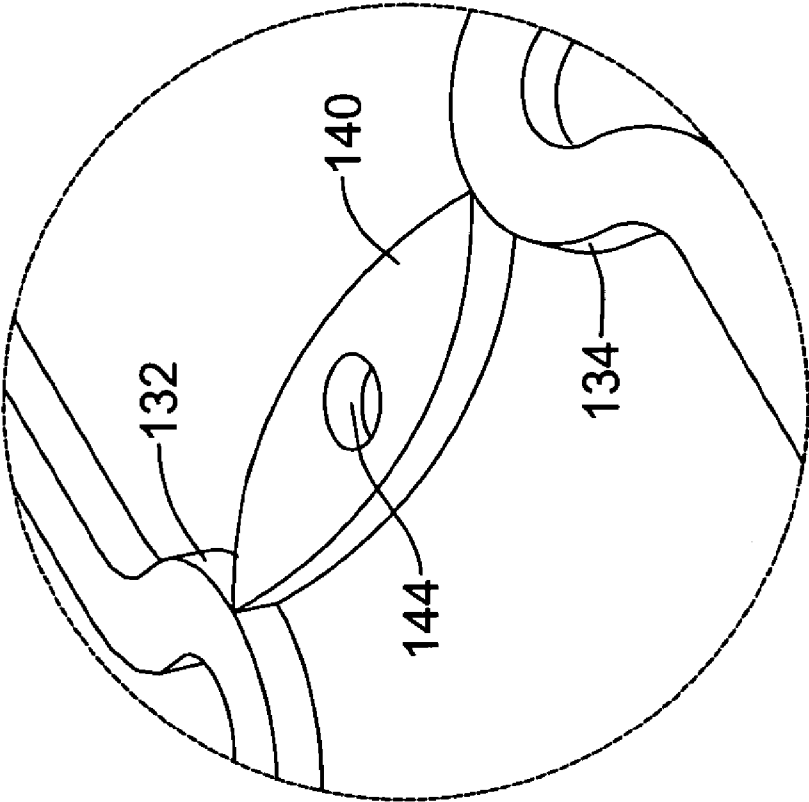

Figure 2C



*Figure 2D*

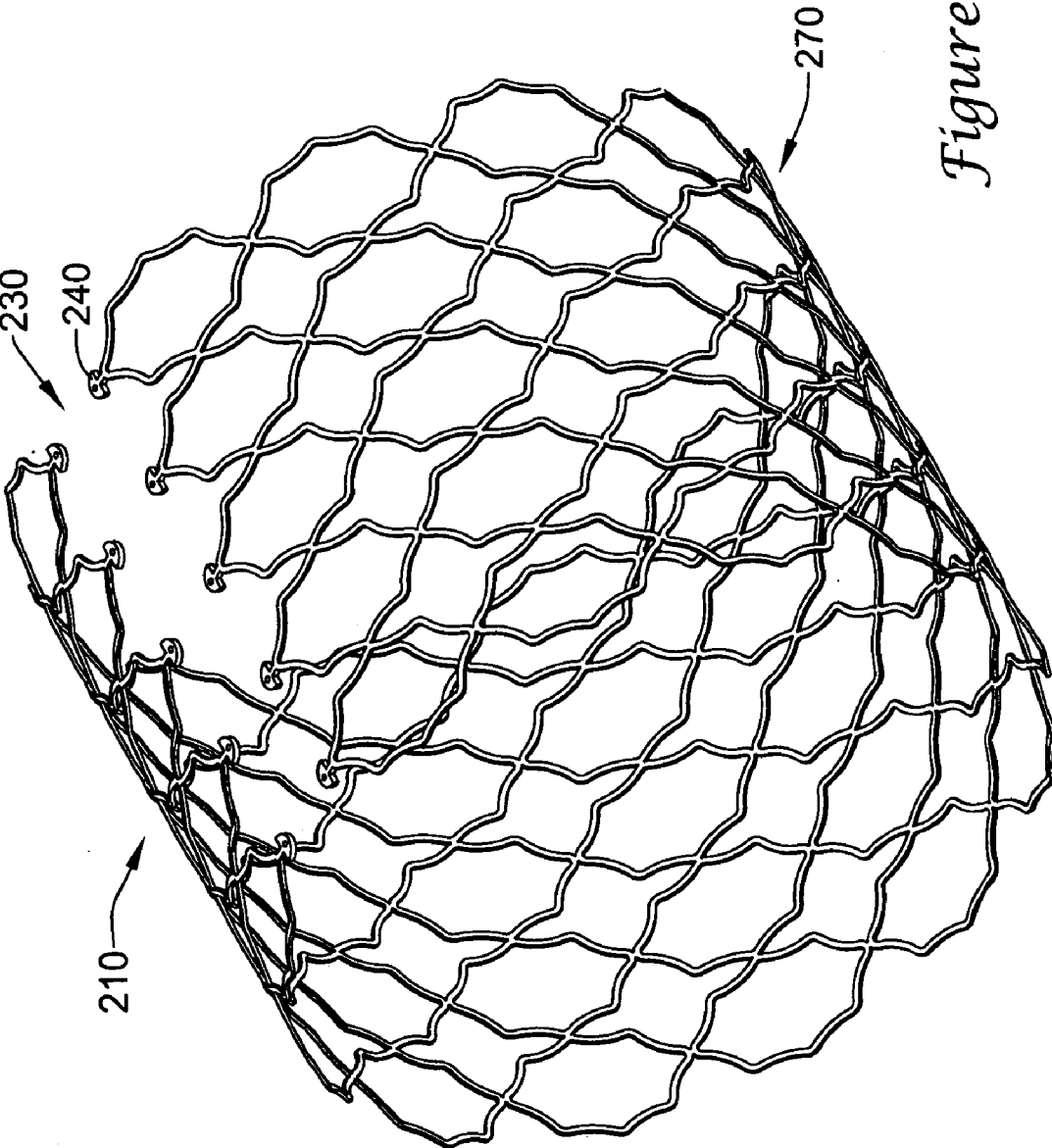

Figure 3A

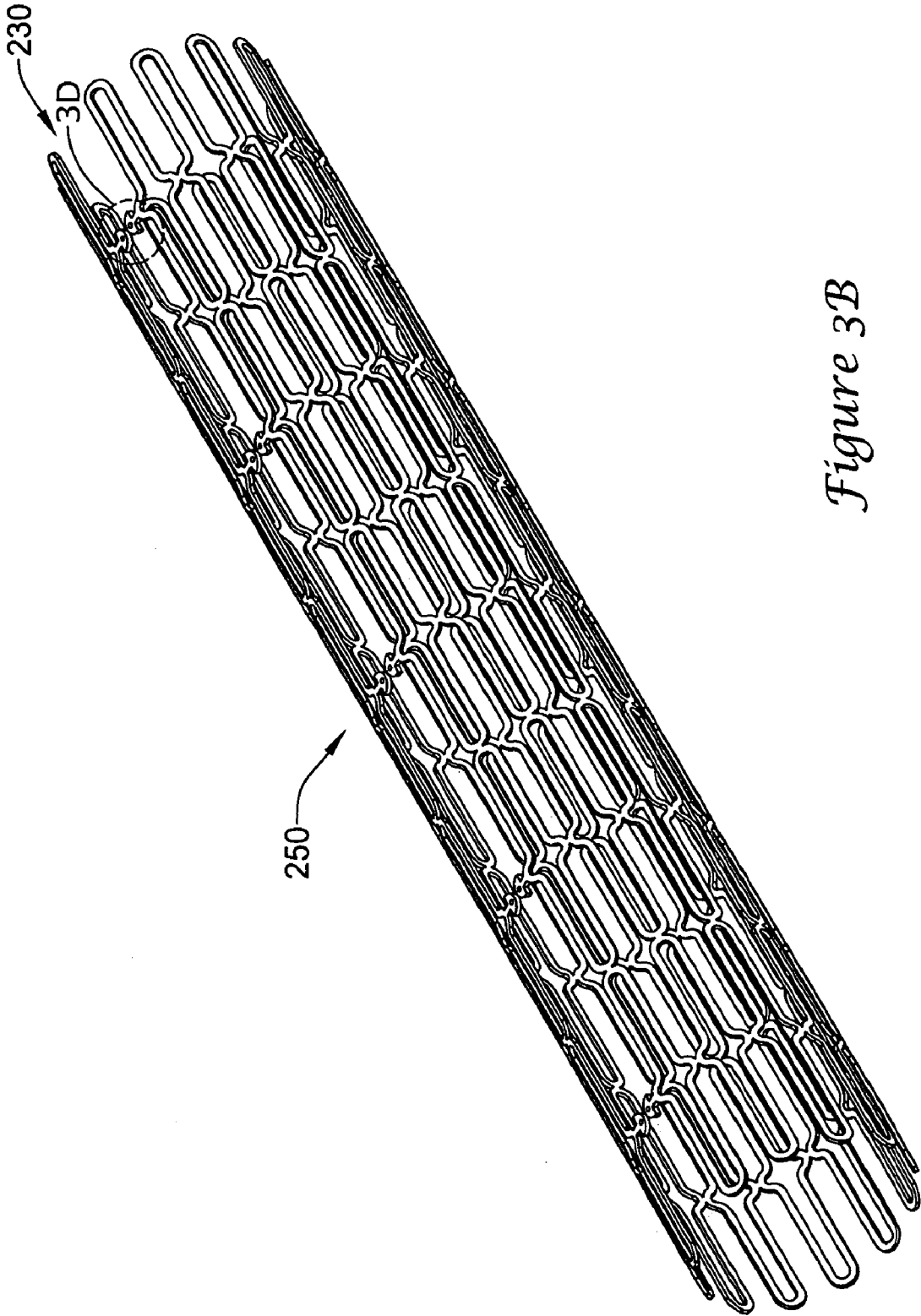

Figure 3B

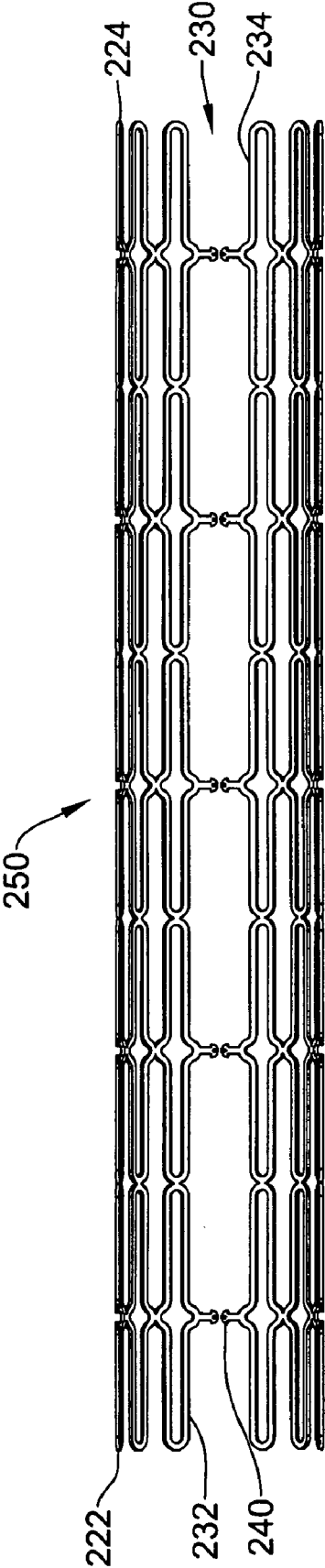

Figure 3C

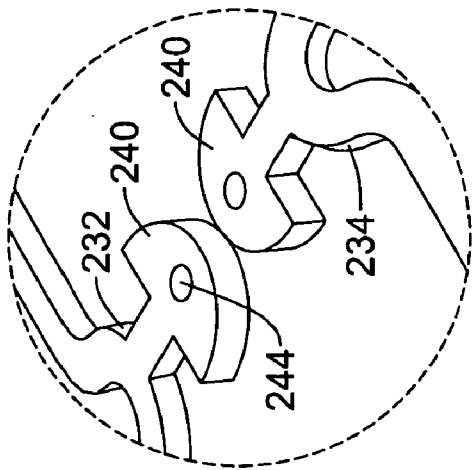

Figure 3D

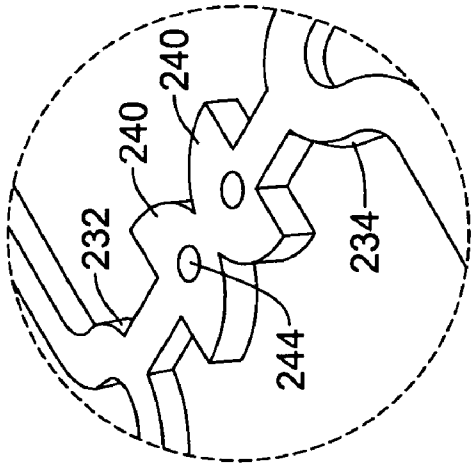

Figure 3E

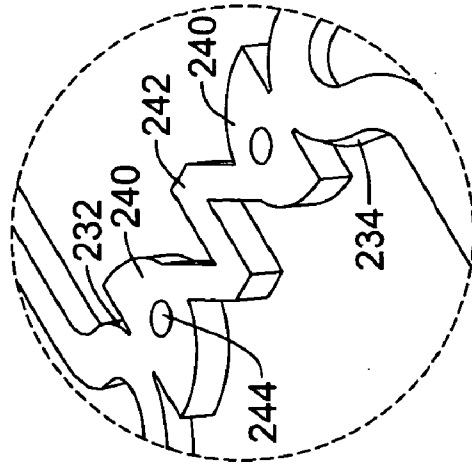

Figure 3F

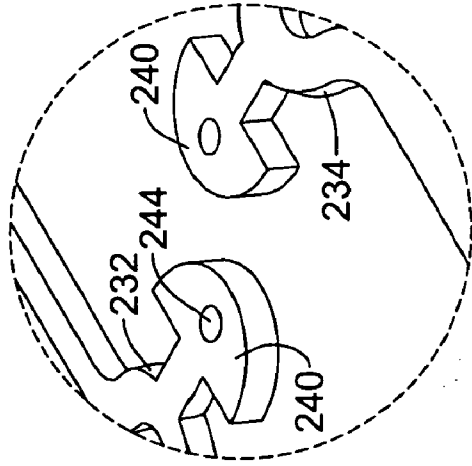

Figure 3G

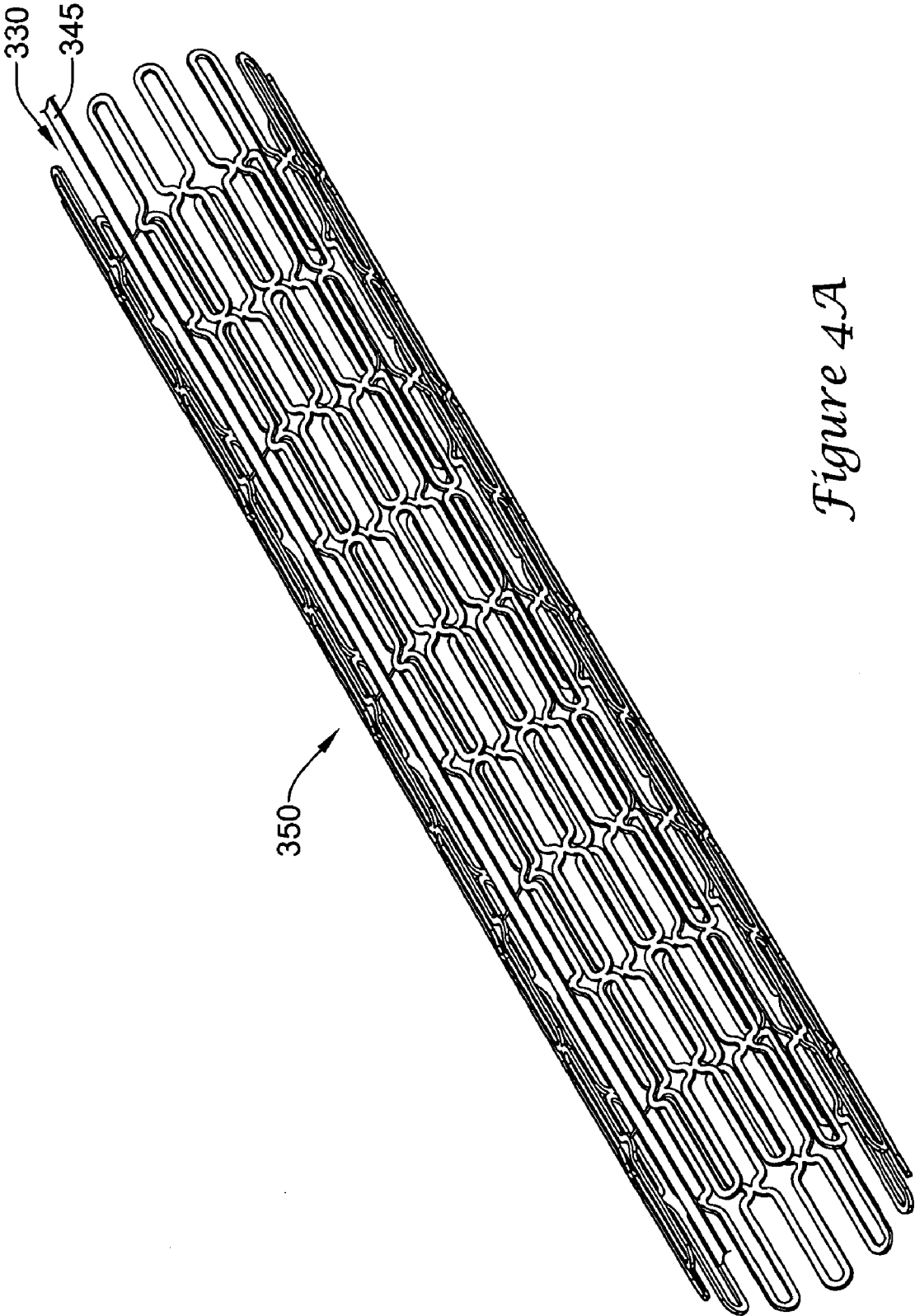

Figure 4A

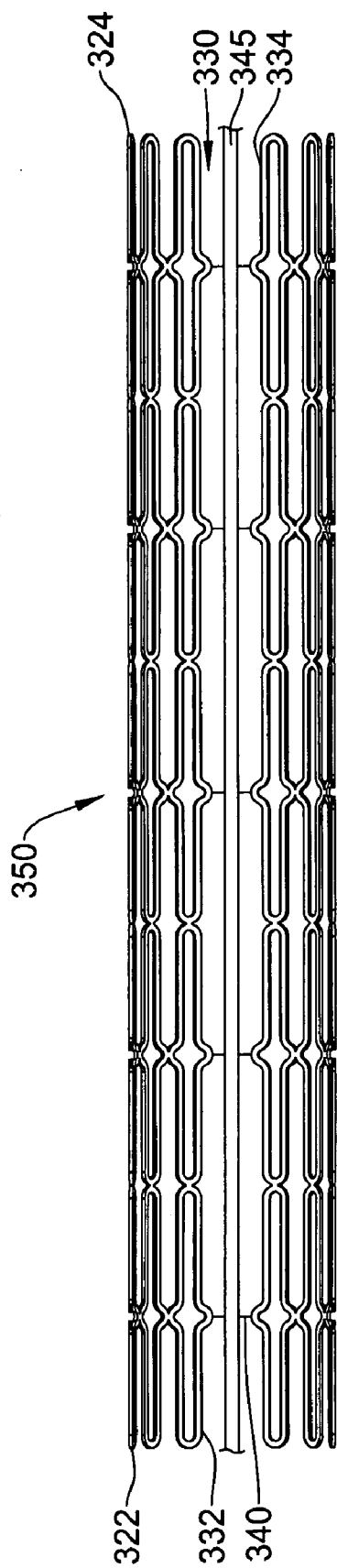

Figure 4B



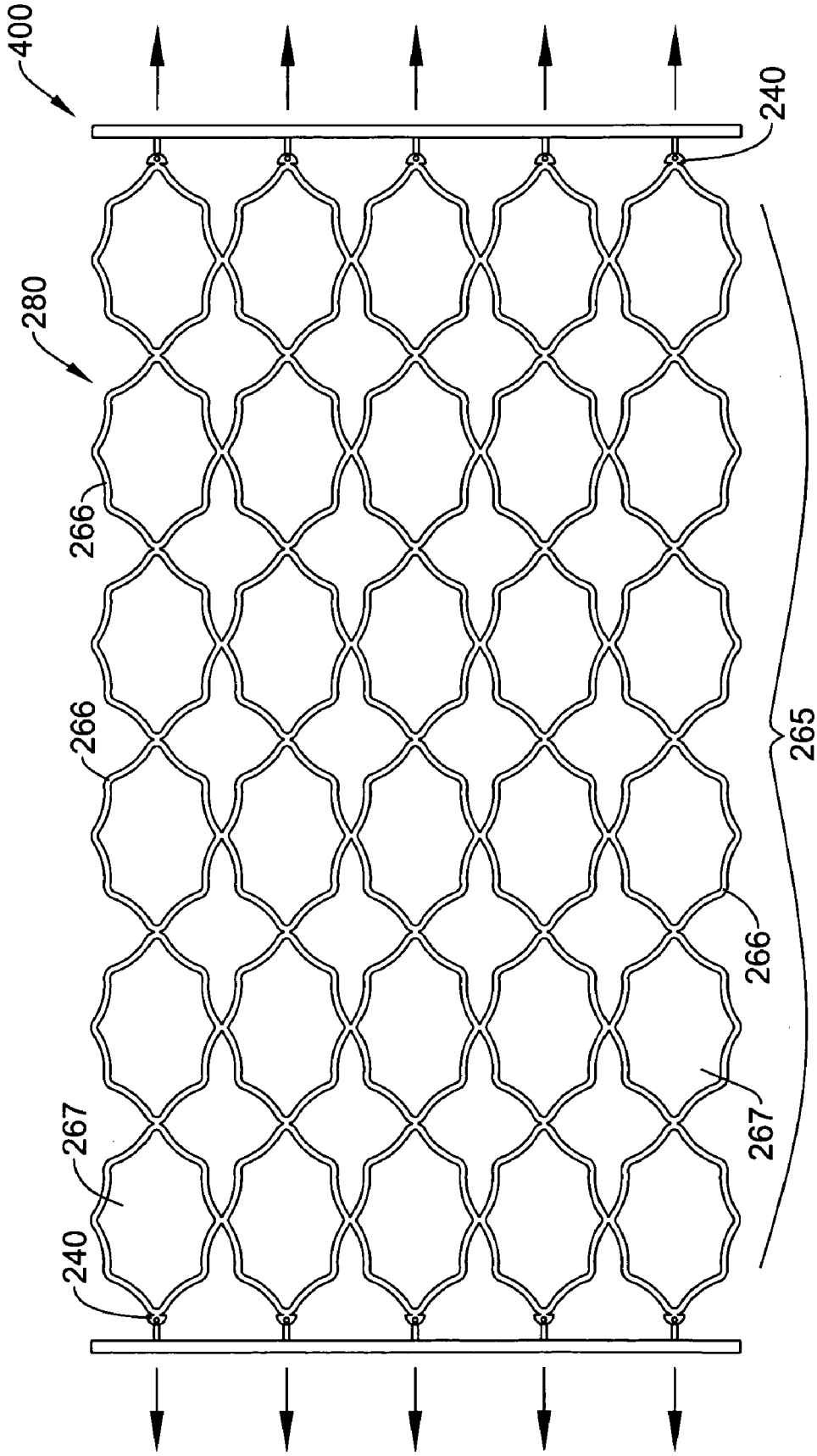

Figure 5

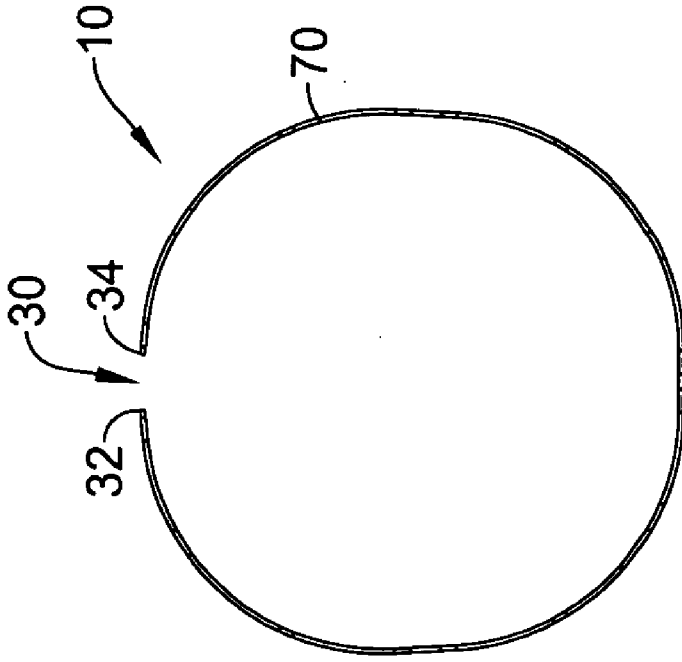

Figure 7

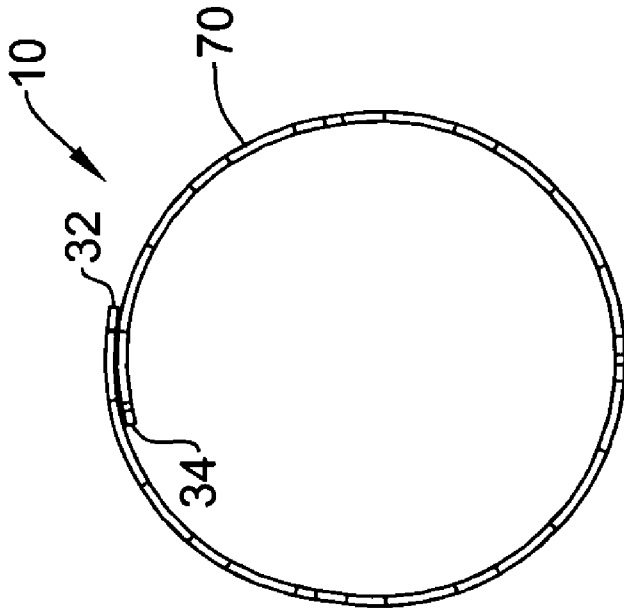

Figure 6

**TUBULAR STENT AND METHODS OF MAKING THE SAME**

**TECHNICAL FIELD**

[0001] This invention generally relates to stents and methods of making a stent from a tubular member for placement within a body lumen or interior space of a body during a medical procedure.

**BACKGROUND**

[0002] Stents are expandable endoprosthetic devices adapted to be placed in a body lumen in order to maintain the patency of a body lumen by providing a flow pathway and/or structural support, for example. Stents are typically used in the treatment of atherosclerotic stenosis in blood vessels and the like to reinforce body vessels and to prevent restenosis following angioplasty in the vascular system. Additionally, stents may be used in the treatment of aortic aneurysms, by providing strength to a weakened vascular wall. They have also been implanted in other body lumens, such as urinary tracts and bile ducts. Stents are generally tubular structures that may be radially expandable between an unexpanded size and an expanded size greater than the unexpanded size. Therefore, a stent may be inserted through a body lumen in an unexpanded state and then expanded at a specific location within the lumen to an expanded state.

[0003] As the use of stents in a variety of medical procedures is gaining widespread acceptance, it is desirable to provide improved methods of manufacturing stents in order to increase efficiency, reduce costs, and/or minimize material waste. The disclosed stents and accompanying methods of manufacturing a stent may be deemed advantageous in view of the increased usage of stents during medical procedures.

**SUMMARY**

[0004] The invention is directed to a stent manufactured from a tubular member. The stent may be cut from a tubular member such that a pattern and an opening extending from the first end to the second end of the tubular member are cut therein. The opening may define a first edge and a second edge through the wall of the tubular member. One or more connectors may be cut along either the first or second edge and may extend into the opening.

[0005] Accordingly, a process of making a stent from a tubular member is disclosed. A tubular structure having a pattern configured to provide expansion and an opening defining a first edge and a second edge may be cut from a tubular member. The opening may be cut such that one or more connectors may be cut along either the first or second edge and extend into the opening.

**BRIEF DESCRIPTION OF THE DRAWINGS**

[0006] The invention may be more completely understood in consideration of the following detailed description of various embodiments in connection with the accompanying drawings, in which:

[0007] **FIG. 1A** is a perspective view of an exemplary stent within the scope of the invention;

[0008] **FIG. 1B** is a perspective view of an exemplary embodiment of a pattern cut in a tubular member to form a stent within the scope of the invention;

[0009] **FIG. 1C** is a cut away view of the tubular member of **FIG. 1B**, more easily showing an opening cut along the tubular member including exemplary connectors within the scope of the invention;

[0010] **FIG. 1D** is a perspective view of the tubular structure formed after expansion of the tubular member of **FIG. 1B**;

[0011] **FIGS. 1E-1F** are enlarged views of exemplary embodiments of connectors within the scope of the invention;

[0012] **FIG. 2A** is a perspective view of another exemplary stent within the scope of the invention including a plurality of connectors extending across an opening;

[0013] **FIG. 2B** is a perspective view of an exemplary embodiment of a pattern cut in a tubular member to form a stent within the scope of the invention;

[0014] **FIG. 2C** is a cut away view of the tubular member of **FIG. 2B**, more easily showing an opening cut along the tubular member including exemplary connectors within the scope of the invention;

[0015] **FIG. 2D** is an enlarged view of an exemplary connector extending across an opening cut in a tubular member within the scope of the invention;

[0016] **FIG. 3A** is a perspective view of another exemplary stent within the scope of the invention;

[0017] **FIG. 3B** is a perspective view of an exemplary embodiment of a pattern cut in a tubular member to form a stent within the scope of the invention;

[0018] **FIG. 3C** is a cut away view of the tubular member of **FIG. 3B**, more easily showing an opening cut along the tubular member including exemplary connectors within the scope of the invention;

[0019] **FIGS. 3D-3G** are enlarged views of exemplary embodiments of connectors comprising tooling nodes within the scope of the invention;

[0020] **FIG. 4A** is a perspective view of an exemplary embodiment of another tubular member to form a stent within the scope of the invention;

[0021] **FIG. 4B** is a cut away view of the tubular member of **FIG. 4A**, more easily showing an opening cut along the tubular member including a spine extending along the opening within the scope of the invention;

[0022] **FIG. 5** is a plan view illustrating an exemplary device for elongating and/or forming the tubular member of **FIG. 3B**;

[0023] **FIG. 6** is a plan view illustrating forming an exemplary stent having overlapping edges within the scope of the invention; and

[0024] **FIG. 7** is a plan view illustrating forming an exemplary stent having a C-shape within the scope of the invention.

**DETAILED DESCRIPTION**

[0025] As used in this specification and the appended claims, the singular forms "a", "an", and "the" include plural referents unless the content clearly dictates otherwise. As

used in this specification and the appended claims, the term “or” is generally employed in its sense including “and/or” unless the content clearly dictates otherwise.

[0026] The following detailed description should be read with reference to the drawings in which similar elements in different drawings are numbered the same. The detailed description and the drawings, which are not necessarily to scale, depict illustrative embodiments and are not intended to limit the scope of the invention. The illustrative embodiments depicted are intended only as exemplary. Selected features of any illustrative embodiment may be incorporated into an additional embodiment unless clearly stated to the contrary.

[0027] Referring now to the drawings, and particularly **FIG. 1A**, illustrates an exemplary stent **10** within the scope of the invention. As discussed herein, stent **10** may be formed from a tubular member. Stent **10** may be manufactured from a variety of materials. For example, stent **10** may include a nickel-titanium alloy, such as a shape memory material commonly referred to as nitinol, which may provide the stent **10** with superelastic properties, pseudoelastic properties, or linear elastic properties. Other suitable materials for the stent include, but are not limited to, stainless steels and their alloys, composites, platinum enhanced stainless steel, layered materials, niobium (Nb), zirconium (Zr), Nb—Zr alloys, tantalum (Ta), platinum (Pt), titanium (Ti), gold (Au), silver (Ag), magnesium (Mg), and alloys and compositions comprising the same. Polymers, polymer composites, and combinations and mixtures thereof, may also be used. Stent **10** may be treated or coated with an anti-thrombogenic agent, an anti-proliferative agent, an anti-inflammatory agent, or an anti-coagulant. Additionally or alternatively, stent **10** may be treated or coated with a medication, such as a time-release drug. Stent **10** may also desirably have radiopaque characteristics for visualization on a fluoroscopy device, which may aid in proper placement of the stent **10** during a medical procedure. For example, stent **10** may be doped with, plated with, or otherwise include a radiopaque material. Radiopaque materials are understood to be materials capable of producing a relatively bright image on a fluoroscopy screen or another imaging technique during a medical procedure. Some examples of radiopaque materials include, but are not limited to, gold (Au), platinum (Pt), palladium (Pd), tantalum (Ta), tungsten (W), plastic material loaded with radiopaque filler, and the like. Stent **10** may, alternatively or additionally, include MRI compatible materials and/or be coated with one or more MRI compatible coatings.

[0028] Now referring to **FIG. 1B**, stent **10** may be formed from a tubular member **50**. Tubular member **50** may be a thin-walled tube having appropriate dimensions. A pattern **60** may be cut into tubular member **50**. Although a relatively simple pattern of interconnected segments is shown in **FIG. 1B**, numerous patterns of varying design and complexity are possible. A selected pattern **60** may dictate the degree of expansion and/or flexibility of stent **10**. Pattern **60** may be cut into tubular member **50** by a laser cutting device controlled by a computer automated system, for example a computer numerically controlled (CNC) machine. Such a laser cutting device may be able to replicate a very intricate and precise pattern **60**. A laser beam, for example, or a laser beam traveling through a fluid jet may be directed at the tubular member **50**. The tubular member **50** may be trans-

lated and/or rotated relative to the position of the laser, or vice versa, in order to cut the desired pattern **60**. The lumen **20** of the tubular member **50** may be subjected to a fluid column to flush dross from the tubular member, provide cooling to the cutting zone, and/or deflect the laser beam from the opposing wall of the tubular member **50** during the cutting process. The fluid column may be a gas and/or a liquid, and a single or multiple fluid columns may be provided through the lumen **20**. For example, two fluid columns may be separated by a tubular mandrel disposed within the lumen **20** of the tubular member **50**, such that a first column of fluid is positioned in the annular space between the tubular member **50** and the mandrel and a second fluid column is positioned in the lumen of the tubular mandrel. Such a laser cutting process is disclosed in U.S. Pat. No. 6,696,666 entitled Tubular Cutting Process and System, which is herein incorporated by reference in its entirety. Other cutting techniques may include optical etching, chemical etching, electron beam ablation, material deposition, as well as other laser ablation techniques.

[0029] **FIG. 1C** shows a cut away view of tubular member **50**. An opening **30** may be cut through tubular member **50** during the cutting process or during an additional cutting process. Opening **30** may extend from the first end **22** of the tubular member **50** to the second end **24** of the tubular member **50**. Opening **30** defines a first edge **32** and an opposing second edge **34** of the wall of the tubular member **50** and may extend from the first end **22** to the second end **24**. Edges **32**, **34** may extend from the outer surface to the inner surface of the wall of the tubular member **50**. Opening **30** may extend substantially longitudinally along tubular member **50**. However, opening **30** may extend helically around the tubular member **50**, providing a helical configuration of opening **30** along the length of tubular member **50**, undulate along at least a portion of the length of tubular member **50**, or otherwise extend along tubular member **50** in a regular or irregular manner.

[0030] One or more connectors **40** may be cut along the first edge **32** and extend into the opening **30**. Additionally or alternatively, one or more connectors **40** may be cut along the second edge **34** and extend into the opening **30**. Connectors **40** may be positioned adjacent one another and extend from opposing edges **32**, **34** of the tubular member **50**, or connectors **40** may be alternated along at least a portion of the length of the opening **30**. A connector **40** may extend from the first edge **32** toward the second edge **34** and be attached to a connector **40** extending from the second edge **34** toward the first edge **32**, thus creating one continuous connector **40** spanning the opening **30** between the first edge **32** to the second edge **34**. Alternatively, opposing connectors **40** may not be attached to one another, thus a space may remain between opposing connectors **40**.

[0031] **FIGS. 1E and 1F** show two possible embodiments of connector **40**. As shown in **FIG. 1E**, connector **40** may be a serpentine or zig-zag shaped strut extending from the first edge **32** to the second edge **34**. The shape and size of connector **40** may be dimensioned such that the connector **40** may be elongated a predetermined amount during a subsequent expansion process. **FIG. 1F** shows another embodiment of a connector **40** similar to that shown in **FIG. 1E**. Connector **40** may have a serpentine or zig-zag shape having a grasping portion, such as an eyelet **42**. The eyelet **42** may be substantially located in the central portion of the

connector 40, or eyelet 42 may be located at any position along connector 40. An aperture, such as hole 44 may extend through eyelet 42. Hole 44 may allow a tooling device to be coupled or otherwise be engaged with the connector 40. Eyelet 42 may be used to retain and/or manipulate the stent 10 during a subsequent manufacturing process. The aperture may extend through eyelet 42 or the aperture may be a recess or pocket with a terminus within the thickness of connector 40. Other configurations of connectors, such as connectors with a grasping portion such as tabs, slots, slits, projections, grooves, loops, or hooks are contemplated to be within the scope of the invention.

[0032] Referring now to FIG. 1D, the tubular member 50 may be expanded subsequent to cutting the pattern 60 in the tubular member 50. The resulting tubular structure 70 may have an outer diameter greater than the initial diameter of the tubular member 50. Tubular member 50 may be expanded by placing a mandrel through the lumen 20 of tubular member 50 or by other means for expanding the tubular member 50. The expanded tubular structure 70 may be a mesh 65 including a plurality of interconnected segments 66 formed from the material of the tubular member 50 remaining after cutting the pattern 60 in the tubular member 50. The interconnected segments 66 are spaced farther apart after expansion to create the mesh 65 having a plurality of interstices 67 disposed therein. The specific pattern 60 cut into the tubular member 50 and/or the material used may dictate the degree of expansion of the tubular structure 70.

[0033] As a result of the expansion of the tubular structure 70, connectors 40 may become elongated. Connectors 40 may provide support and/or continuous structure in order to ensure uniform, non-uniform or an otherwise predetermined expansion of the tubular structure 70. Therefore, the tubular shape of the structure 70 may be maintained throughout the expansion process. For example, connectors 40 may be configured to have a degree of expansion similar to that of the pattern 60. Therefore, the circumferential expansion of the tubular structure 70 may be uniform at all locations around the circumference of the tubular structure 70. Connectors 40 may be configured to provide visual confirmation of proper expansion, such as when the connectors 40 are sufficiently straightened. Therefore, the tubular structure 70 may reach its proper expanded dimensions when the connectors 40 have reached a sufficient elongated configuration. Alternatively, connectors may be configured to provide visual confirmation of proper expansion of the tubular member 50 at the point where elongation of connectors 40 commences or at the point of fracture of connectors 40 from tubular member 50.

[0034] Connectors 40 may be sufficiently frangible such that connectors 40, or a portion thereof, may be separated from the tubular structure 70 subsequent expansion of the tubular structure 70, or connectors 40 may be retained with the tubular structure 70. Connectors 40 may be removed during a subsequent process using mechanical, electrical or chemical techniques. A cutting process may be used to provide separation from the edge 32, 34 of the structure 70. For example, a laser ablation technique may be used to separate the connectors 40 from the tubular structure 70 or weaken the interface between connector 40 and tubular structure 70. Connectors 40 may be removed by mechanically cutting, snipping, breaking or otherwise severing the connectors, or by grinding, sandblasting or otherwise erod-

ing away material. Additionally or alternatively, a chemical etching or electro-polishing process may be used to remove connectors 40 or a portion thereof. Connectors 40 may be dissolved or weakened during a subsequent manufacturing process in which a portion of the material is eroded away.

[0035] FIG. 2A shows a tubular structure 170 forming another stent 110, similar to stent 10. Stent 110 may be similarly formed from a tubular member 150. Tubular structure 170, shown in FIG. 2A, includes connectors 140 coupled to stent 110 subsequent to expansion of the stent 110. However, connectors 140 may be removed from stent 110 during or subsequent the expansion process, as discussed herein. With connectors 140 removed, stent 110 may substantially replicate stent 10 illustrated in FIG. 1A. As shown in FIG. 2B, a pattern 160 may be cut through tubular member 150. Additionally, an opening 130 may extend from the first end 122 to the second end 124 of the tubular member 150. As shown in the cut away view in FIG. 2C, the opening 130 defines a first edge 132 and a second edge 134 of the wall of the tubular member 150. One or more connectors 140 may be cut in the tubular member 150 such that connector 140 extends across the opening 130 from the first edge 132 to the second edge 134. Connector 140, which may more clearly be understood from FIG. 2D, may be connected to opposing edges 132, 134 of the tubular member 150. Connector 140 may have one or more apertures, such as holes 144 used to retain and/or manipulate the tubular structure 170 during a manufacturing process. The aperture may extend through the wall of tubular structure 170 or the aperture may be a recess or pocket with a terminus within the wall of tubular structure 170. Other configurations of connectors, such as connectors having a grasping portion including tabs, slots, slits, projections, grooves, loops, or hooks are contemplated to be within the scope of the invention. Hole 144 may be located in the central portion of connector 140, or hole 144 may be located at another location of connector 140. Connector 140 may provide support and/or continuous structure in order to ensure uniform, non-uniform or otherwise proper expansion of the tubular structure 170 during expansion of the stent 110. Therefore, the tubular shape of the structure 170 may be maintained throughout the expansion process. Connector 140 may allow the tubular structure 170 to retain a uniform diameter during expansion of the stent 110. The connection between the connector 140 and the edge 132, 134 of the tubular structure 170 may be a weakened zone or an otherwise frangible region, such that prior to providing the finished product stent 110, connector 140 may be removed. The connector 140, or a portion thereof, may be removed by mechanically cutting, snipping, breaking, grinding, sandblasting, laser ablation, chemical etching, electro-polishing, or other processes wherein the connector 140 is separated, eroded or dissolved from the tubular structure 170.

[0036] FIG. 3A illustrates a stent 210 similar to stent 10 in an expanded configuration. Stent 210 may include one or more connectors 240, as discussed herein. As shown in FIG. 3B, stent 210 may be cut from a tubular member 250 such as discussed above. An opening 230, which may more easily be shown in the cut away view of FIG. 3C, may be cut along tubular member during a cutting process and may extend from the first end 222 to the second end 224 of the tubular member 250. One or more connectors 240 may be cut in tubular member 250, such that connectors 240 extend from edge 232, 234 of tubular member 250 into opening 230. As

more clearly shown in **FIGS. 3D-3G**, connectors **240** may be tooling nodes. Connectors **240** may be configured to be coupled to or otherwise engaged with a tooling apparatus. Connectors **240** may be used to retain and/or manipulate the tubular structure **270** during a subsequent manufacturing process. As shown in **FIG. 3D**, connectors **240** may extend from edge **232, 234** toward an opposing edge. However, connectors **240** may not be connected to one another. Instead, a gap may be maintained between adjacent connectors **240**. Although connectors **240** are shown adjacent one another, opposing connectors **240** may alternate along the length of the tubular structure **270**, such as shown in **FIG. 3G**. Alternatively, connectors **240** may extend toward an adjacent connector **240** and be connected to an adjacent connector **240**, as shown in **FIG. 3E**. The connection between adjacent connectors **240** may be a weakened zone or an otherwise frangible region. For example, the connection may be a region of reduced cross sectional area or an area scored during a cutting process. Such a configuration of connectors **240** may be separated during a subsequent manufacturing process. For example, connectors **240** may be separated by mechanically cutting, snipping, breaking, grinding, sandblasting, laser ablation, chemical etching, or electro-polishing. **FIG. 3F** illustrates yet another embodiment of connectors **240**. A strut **242** may bridge a pair of connectors **240** extending from opposing edges **232, 234** of the tubular structure **270**. Strut **242** may have a serpentine or zig-zag shape or otherwise have an extendable shape. During an expansion process, strut **242** may be elongated similar to connectors **40** discussed above regarding **FIGS. 1A-1F**. Therefore, strut **242** may provide support and/or continuous structure around the circumference of the tubular structure **270** in order to ensure uniform, non-uniform or otherwise proper expansion of the tubular structure **270**. Therefore, the tubular shape of the structure **270** may be maintained throughout the expansion process. Elongation of the strut **242** may be a visual indicator of proper expansion of the tubular structure **270**. Sufficient elongation of the strut **242** may indicate the tubular structure **270** has reached its predetermined expanded configuration. Subsequent to expansion of the tubular structure **270**, strut **242** may be removed by mechanical, electrical or chemical means. For example, strut **242** may be removed by laser ablation, cutting, snipping, breaking, grinding, sandblasting, or prior to or during a chemical etching or electro-polishing process.

[0037] Alternatively or additionally, a wire or filament may be extend between connectors **240** to join opposing or alternating connectors. For example, the wire may be laced or threaded through holes **244** of connectors **240**. The wire may be a temporary connector which extends across opening **230**. The wire may substantially restrain separation of opposing edges **232, 234** or tubular structure **270**. The wire may provide support and/or continuous structure to the tubular member **250** to ensure uniform, non-uniform or an otherwise predetermined expansion of the tubular structure **270**. Therefore, the tubular shape of the structure **270** may be maintained throughout the expansion process. Subsequent expansion and/or forming of the tubular structure **270**, the wire may be removed from the structure **270**. The wire may be removed by mechanical, electrical or chemical means. The wire may be dissolvable whereby it is dissolved with a solvent, by a thermal process, a chemical process or an electrical process. The wire may have characteristics similar to a dissolvable suture. Alternatively, wire may be

mechanically removed by a laser, grinding, sandblasting, cutting, snipping, etching, breaking, or by another process.

[0038] Additionally or alternatively, connectors, such as connectors **240**, having an aperture such as a recess, may include an adhesive. The adhesive, which may be disposed in the recess of the connector **240**, may be used to secure one portion of the tubular structure **270** with another portion of the tubular structure **270**. For example, one connector **240** may be adhesively secured to an opposing connector **240**. The adhesive may also be used to secure the tubular structure **270** to another apparatus for forming and/or processing of the tubular structure **270**. The adhesive may be dissolvable, or otherwise provide temporary securement, or the adhesive may be intended to provide permanent securement.

[0039] Alternatively or additionally, an apparatus such as a mandrel having hooks, tines, clips, or other engagement means, may be used to engage connectors **240**. The mandrel may substantially couple opposing edges **232, 234** such that edges **232, 234** are restrained from separation during expansion of the tubular structure **270**. For example, the hooks of the mandrel may be inserted in holes **244** of connectors **240**. The mandrel may provide support and/or continuous structure to the tubular member **250** to ensure uniform, non-uniform or an otherwise predetermined expansion of the tubular structure **270**. Therefore, the tubular shape of the structure **270** may be maintained throughout the expansion process. Subsequent expansion and/or forming of the tubular structure **270**, the mandrel may be removed from the structure **270**. Although the mandrel may engage connectors **240**, mandrel may also engage another portion of the stent to restrain separation of opposing edges **232, 234**.

[0040] **FIG. 4A** shows another embodiment of a tubular member **350** for forming a stent within the scope of the invention. As more easily shown in **FIG. 4B**, tubular member **350** may be cut with an opening **330** extending from a first end **322** to a second end **324**. A connecting spine **345** may be disposed along opening **330**. One or more connectors **340** may extend from edge **332, 334** to connecting spine **345**. An electrical current of a sufficient magnitude may be applied to the connecting spine **345** to remove the connectors **340**. The connectors **340** may be sufficiently thin relative to the other portions of the tubular member **350**, such that the magnitude of the electrical current and/or the geometry of the connectors **340** is sufficient to remove the connectors **340** from the stent. Alternatively, an electrical current may be directly applied to the connectors **340**, thus alleviating the need for the connecting spine **345**.

[0041] Connectors **240**, characterized as tooling nodes as shown in **FIGS. 3D-3G**, may be used to retain and manipulate tubular structure **250** during a subsequent process. For example, **FIG. 5** illustrates an exemplary process wherein a tooling device **400** is coupled to or otherwise engaged with one or more connectors **240**. Tooling device **400** may be manipulated such that tubular member **250** is unrolled and/or elongated into a substantially planar sheet **280**. Thus, interconnected segments **266** may be sufficiently directed away from one another to form a mesh **265** with a plurality of interstices **267** disposed thereon. While elongated in a substantially planar sheet **280**, the sheet may be subjected to one or more additional processes, such as a heat treatment process, a cleaning process, a chemical etching process, an electro-polishing process, a quenching process, a coating

process, or another chosen process. Sheet **280** may undergo a forming process, wherein the sheet **280** is rolled into a tubular stent. Additional processes, such as a heat treatment process, a cleaning process, an electro-polishing process and/or a coating process may follow rolling the sheet **280** into a tubular stent. Tooling device **400**, or an additional tooling device, may be used to re-roll or otherwise form the sheet **280** into a tubular stent or an intermediate form. For example, a mandrel having clips, tines, hooks or other means of engaging the structure may be used to expand, roll, form, wrap or otherwise manipulate the structure to form a stent.

[0042] Any one of the previously disclosed tubular structures may further be rolled into a coil stent. As shown in **FIG. 6**, a stent, such as stent **10** may be wrapped such that the first edge **32** of the tubular structure **70** overlaps the second edge **34**. The degree of overlap may be determined by the profile necessary to provide sufficient clearance through a body lumen, such as a blood vessel, and/or the degree of expansion necessary to provide sufficient patency of a body lumen. A tooling device, such as a mandrel, may be coupled to one or more connectors **40** along one edge of stent **10** and rotated such that the first edge **32** is urged toward the second edge **34**. Thus the stent **10** may be wrapped into a chosen tubular shape such as a coiled overlapping configuration. However, stent **10** may be rolled into a coil using other mechanical means. Alternatively, stent **10** may be rolled such that edge **32** substantially abuts edge **34** to form a generally continuous tubular structure. Edge **32** may be secured to edge **34** by welding, brazing, soldering, bonding, adhesive, mechanically coupling, crimping, or the like, or edges **32**, **34** may remain unconnected.

[0043] Alternatively, one of the previously disclosed tubular structures may be formed in a C-shape such as shown in **FIG. 7**. A stent **10** having a C-shape may be readily expanded within a lumen to provide necessary patency of the lumen. The opening **30** extending along the length of the stent **10** allows opposing edges **32**, **34** to deflect away from one another when stent **10** is allowed to expand within a lumen. Stent **10** may be formed into a C-shape during a subsequent forming/rolling process, or C-shape may be the result of cutting a tubular member **50** and expanding into a tubular structure **70** having a longitudinal, helical, undulating or otherwise elongate opening **30** as discussed above.

[0044] Any one of the previously described stent forming processes may include one or more further processing steps. For example, the tubular member may be subjected to a cleaning process to remove dross or residue subsequent a cutting process. For instance, an alcohol and/or water solution may be used to clean foreign material from the tubular structure. A chemical etching process may be used to remove connectors and/or other material from the tubular structure to provide a surface with no sharp edges or burrs. An electro-polishing process may be used to reduce the surface roughness of the machined tubular member and provide a stent having a substantially smooth outer surface. An electro-polishing process, or similar electrical process, may also be used to dissolve or otherwise separate a connector from the stent. For example, an electro-polishing process may dissolve a percentage of the mass of the material forming the stent. By dimensioning the connectors relatively small compared to the material of the interconnected segments of the stent, the connectors will completely dissolve, erode or otherwise be separated from the stent without fully dissolv-

ing the interconnected segments during an electro-polishing process. An electrical current of a sufficient magnitude may be applied to the connectors to separate the connectors from the stent. Additionally, a stent may be subjected to one or more heat treating processes in order to remove residual stresses and/or provide favorable characteristics to the stent, such as shape memory properties.

[0045] One illustrative stent forming process may include a plurality of processes. Initially a stent may be laser cut from a tubular member as discussed above. The stent may then be subjected to a chemical etching and/or electro-polishing process to remove residue, connectors and/or rough edges remaining after being cut from the tubular member. Alternatively or additionally, the stent may be placed in an ultrasonic cleaning process. Next, the stent may be expanded or otherwise formed by rolling and/or tucking the ends of the stent. Once formed, the stent may be heat treated to remove any residual stresses and/or provide shape memory properties and then quenched. The stent may then undergo a final cleaning process to remove any remaining residue. Additional processes, such as chemical etching, electro-polishing, cleaning or heat treating, may be included throughout. For example, the stent may be subjected to a chemical etching or electro-polishing process subsequent to being expanded in order to remove temporary connectors from the stent.

[0046] It is contemplated that the disclosed process of forming a stent may be substantially used to form other similar products from a tubular member. For example, a filter mesh or frame for an intravenous filter or distal protection device may be formed utilizing the disclosed process.

[0047] Those skilled in the art will recognize that the present invention may be manifested in a variety of forms other than the specific embodiments described and contemplated herein. Accordingly, departure in form and detail may be made without departing from the scope and spirit of the present invention as described in the appended claims.

What is claimed is:

1. A method of forming a stent comprising:

providing a tubular structure having a first end and a second end, a wall surface disposed between the first end and the second end, and a lumen extending longitudinally through the tubular structure from the first end to the second end;

cutting a pattern in the wall surface of the tubular structure, the pattern adapted to allow radial expansion or radial contraction of the tubular structure; and

cutting an opening in the wall surface that extends from the first end to the second end of the tubular structure, the opening defining a first edge and a second edge, each extending from the first end to the second end of the tubular structure on either side of the opening.

2. The method of claim 1, wherein the opening extends substantially longitudinally from the first end to the second end of the tubular structure.

3. The method of claim 1, wherein the opening extends substantially helically from the first end to the second end of the tubular structure.

4. The method of claim 1, wherein the opening extends in an undulating course from the first end to the second end of the tubular structure.

5. The method of claim 1, wherein the tubular structure is further processed to form a coiled stent.

6. The method of claim 1, wherein the cutting step is performed with a laser.

7. The method of claim 1, wherein a connector is cut into the wall surface of the tubular structure and extends from the first edge.

8. The method of claim 7, wherein the connector extends into the opening between the first edge and the second edge and connects the first edge to the second edge.

9. The method of claim 7, wherein a first connector is cut into the wall surface of the tubular structure at the first edge and a second connector is cut into the wall surface of the tubular structure at the second edge.

10. The method of claim 9, wherein the first connector and the second connector are not connected.

11. The method of claim 10, wherein the first connector is a tooling node for unrolling, stretching, expanding, handling or rolling the stent.

12. The method of claim 10, wherein the second connector is a tooling node for unrolling, stretching, expanding, handling or rolling the stent.

13. The method of claim 9, wherein the first connector and the second connector are connected, thereby interrupting the opening extending from the first end to the second end of the tubular structure.

14. The method of claim 7, wherein the connector includes an aperture.

15. The method of claim 14, wherein the aperture is a hole extending through the connector.

16. The method of claim 14, wherein the aperture is a recess in the connector.

17. The method of claim 7, wherein the connector is a shape adapted to expand or contract upon expansion or contraction of the tubular structure.

18. The method of claim 17, wherein the connector is a serpentine or zig-zag shape.

19. The method of claim 18, wherein the connector includes a hole extending through the connector.

20. The method of claim 17, wherein the connector is adapted to elongate upon expansion of the tubular structure.

21. The method of claim 9, wherein the tubular structure is processed to remove the first connector from the first edge and the second connector from the second edge.

22. The method of claim 7, wherein the tubular structure is processed to remove the connector from the first edge.

23. The method of claim 7, wherein the tubular structure is processed to form a coiled stent.

24. The method of claim 7, wherein the connector is a plurality of tooling nodes, wherein the plurality of tooling nodes are engaged to unroll the tubular structure from a tubular shape to a substantially planar shape for processing.

25. The method of claim 7, wherein a wire is laced between the first connector and the second connector.

26. The method of claim 1, further comprising a connecting spine extending along the opening, a first connector extending from the first edge to the connecting spine, and a second connector extending from the second edge to the connecting spine.

27. The method of claim 26, further comprising applying an electrical current to the connecting spine.

28. A method of forming a stent, comprising:

providing a tubular member having a first end and a second end, a wall surface disposed between the first end and the second end, and a lumen extending longitudinally through the tubular member from the first end to the second end;

cutting a pattern in the wall surface of the tubular member to form a tubular structure, the pattern adapted to allow radial expansion or radial contraction of the tubular structure; wherein the tubular structure includes an opening defining a first edge and a second edge extending from the first end to the second end of the tubular member; wherein the tubular structure further includes a connector extending from the first edge into the opening; and

expanding the tubular structure.

29. The method of claim 28, further comprising removing the connector from the tubular structure.

30. The method of claim 28, further comprising electro-polishing the tubular structure.

31. The method of claim 28, wherein the tubular structure is expanded into a substantially planar sheet.

32. The method of claim 28, further comprising wrapping the tubular structure into a coil stent.

33. The method of claim 28, wherein the connector includes a tooling node having an aperture.

34. The method of claim 33, wherein the aperture is a hole extending through the tooling node.

35. The method of claim 33, wherein the aperture is a recess in the tooling node.

36. The method of claim 33, further comprising wrapping the tubular structure into a coil stent by gripping the tooling node and wrapping the tooling node toward the second edge.

37. The method of claim 36, wherein the tubular structure is wrapped such that the first edge overlaps the second edge.

38. A tubular structure having a pattern provided therein, the pattern adapted to allow radial expansion or contraction of the tubular structure;

the tubular structure having a first end and a second end with a circumferential wall disposed between the first end and the second end and a lumen extending there-through;

the tubular structure having an opening in the wall extending from the first end to the second end of the tubular structure, the opening defining a first wall edge and a second wall edge extending from the first end to the second end of the tubular structure; and

a connector extending into the opening from the first edge toward the second edge.

39. The tubular structure of claim 38, wherein the connector extends from the first edge to the second edge.

40. The tubular structure of claim 38, wherein the connector includes an aperture.

41. The tubular structure of claim 40, wherein the aperture is a hole extending through the connector.

42. The tubular structure of claim 40, wherein the aperture is a recess in the connector.

43. The tubular structure of claim 38, wherein a first connector extends into the opening from the first edge and a second connector extends into the opening from the second edge.



44. The tubular structure of claim 43, wherein the first connector and the second connector are substantially adjacent each other on opposite sides of the opening.

45. The tubular structure of claim 44, wherein the first connector is connected to the second connector to form a strut.

46. The tubular structure of claim 45, wherein the strut is a shape adapted to elongate upon expansion of the tubular structure.

47. The tubular structure of claim 46, wherein the strut is serpentine or zig-zag shaped.

48. The tubular structure of claim 43, wherein the first and second connectors each include an eyelet having a hole extending therethrough.

49. The tubular structure of claim 43, wherein the first and second connectors are each a tooling node adapted to be gripped to unroll or expand the tubular structure.

50. The tubular structure of claim 43, wherein the first connector overlaps the second connector.

\* \* \* \* \*