



US0D1019893S

(12) **United States Design Patent**
Svendsen et al.

(10) **Patent No.:** **US D1,019,893 S**

(45) **Date of Patent:** **** Mar. 26, 2024**

(54) **NOZZLE**

(71) Applicant: **Melnor, Inc.**, Winchester, VA (US)

(72) Inventors: **Sean Svendsen**, Columbus, OH (US);
Donald Collins Meves, Columbus, OH (US);
Eric James Fickas, Plain City, OH (US)

(73) Assignee: **Melnor, Inc.**, Winchester, VA (US)

(**) Term: **15 Years**

(21) Appl. No.: **29/800,872**

(22) Filed: **Jul. 23, 2021**

Related U.S. Application Data

(62) Division of application No. 29/718,894, filed on Dec. 30, 2019, now Pat. No. Des. 928,288, which is a division of application No. 29/670,349, filed on Nov. 15, 2018, now Pat. No. Des. 875,212, which is a division of application No. 29/598,136, filed on Mar. 23, 2017, now Pat. No. Des. 838,809.

(51) **LOC (14) Cl.** **23-01**

(52) **U.S. Cl.**
USPC **D23/223**

(58) **Field of Classification Search**
USPC D23/226, 213, 223
CPC B05B 9/01
See application file for complete search history.

(56) **References Cited**

U.S. PATENT DOCUMENTS

2,376,881 A	5/1945	Adolph
3,150,829 A	9/1964	Specht et al.
3,820,716 A	6/1974	Bauer
4,903,897 A	2/1990	Hayes
D314,609 S	2/1991	Liaw
D325,620 S	4/1992	Heren
D338,706 S	8/1993	Wang

D340,762 S	10/1993	Wang
D355,953 S	2/1995	Wang
D359,101 S	6/1995	Kuo
D369,853 S	5/1996	Wang
D370,713 S	6/1996	Guo
D372,297 S	7/1996	Wang
D373,813 S	9/1996	Guo
D373,814 S	9/1996	Wang
D387,128 S	12/1997	Wang

(Continued)

FOREIGN PATENT DOCUMENTS

CN 102553757 B 2/2014

OTHER PUBLICATIONS

Best Garden Hose Nozzles & Sprayers: Guide & Recommendations, posted to gardeningproductsreview.com. Available date: Apr. 19, 2014 [site visited Aug. 2, 2023] Available: <https://gardeningproductsreview.com/best-garden-hose-nozzles/> (Year: 2014).*

(Continued)

Primary Examiner — Kevin K Rudzinski
(74) *Attorney, Agent, or Firm* — HEA Law PLLC; Darrin Auito

(57) **CLAIM**

The ornamental design for a nozzle, as shown and described.

DESCRIPTION

FIG. 1 is a rear perspective view of a nozzle;
FIG. 2 is a front elevational view thereof;
FIG. 3 is a rear elevational view thereof;
FIG. 4 is a right side elevational view thereof;
FIG. 5 is a left side elevational view thereof;
FIG. 6 is a top plan view thereof;
FIG. 7 is a bottom plan view thereof; and,
FIG. 8 is a front perspective view thereof.

1 Claim, 6 Drawing Sheets

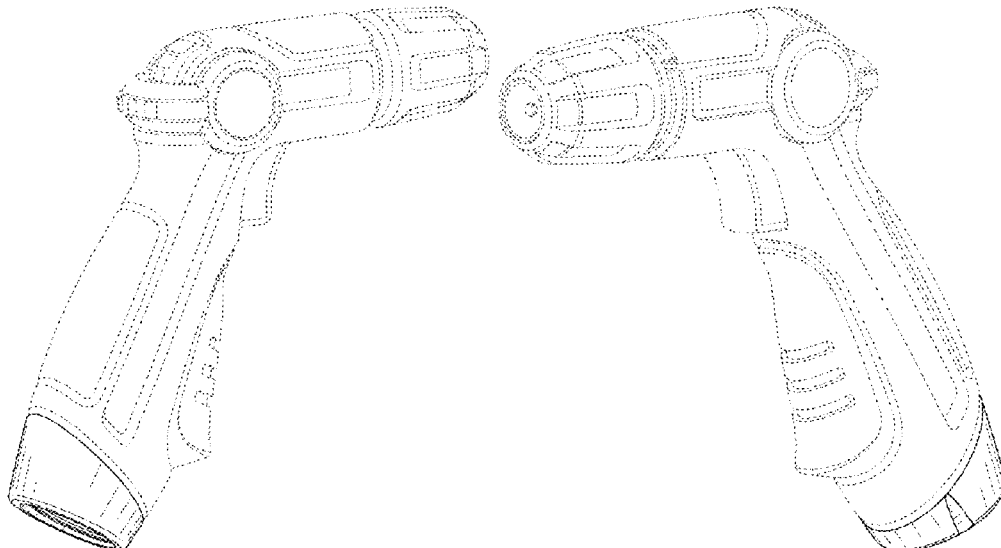

(56)

References Cited

U.S. PATENT DOCUMENTS

5,806,770 A	9/1998	Wang		D726,872 S	4/2015	Thurgood et al.
D402,000 S *	12/1998	Goodin	D23/226	9,073,075 B2	7/2015	Chen
D408,496 S	4/1999	Wang		D736,349 S	8/2015	Wojan
D408,497 S	4/1999	Wang		D736,350 S	8/2015	Cheng
D408,890 S	4/1999	Wang		D746,945 S	1/2016	Näslund
D409,720 S	5/1999	Guo		D746,946 S	1/2016	Näslund
D415,557 S	10/1999	Kuo		D746,947 S	1/2016	Näslund
D417,256 S	11/1999	Kuo		D748,758 S	2/2016	Duong et al.
D431,069 S	9/2000	Heren		D749,696 S	2/2016	Thurgood et al.
D431,280 S	9/2000	Kuo		D760,349 S	6/2016	Chen
D446,282 S	8/2001	Wang		9,427,760 B2	8/2016	Chiu
D446,283 S	8/2001	Wang		D766,400 S	9/2016	Chen
D447,217 S	8/2001	Jacobs et al.		D767,091 S	9/2016	Chen
D447,539 S	9/2001	Tse		D767,094 S	9/2016	Chen
D447,790 S	9/2001	Heren et al.		D767,096 S	9/2016	Chen
D451,981 S	12/2001	Erickson		D768,817 S	10/2016	Chen
D451,982 S	12/2001	Chao		D769,415 S	10/2016	Chen
D452,297 S *	12/2001	Chao	D23/226	D770,017 S	10/2016	Chen
D453,371 S *	2/2002	Wang	D23/226	D771,773 S	11/2016	Chen
D453,814 S *	2/2002	Wang	D23/226	D771,774 S	11/2016	Chen
D454,619 S	3/2002	Wang		D771,775 S	11/2016	Chen
D461,227 S	8/2002	Guo		D774,164 S	12/2016	Chen
D464,707 S *	10/2002	Wang	D23/226	D779,035 S	2/2017	Chen
D467,993 S	12/2002	Chen		D779,036 S	2/2017	Chen
D468,396 S	1/2003	Chen		D779,040 S	2/2017	Chen
D475,122 S	5/2003	Kuo		D779,041 S	2/2017	Chen
D475,435 S	6/2003	Chen		D779,634 S	2/2017	Chen
D475,762 S	6/2003	Kuo		D780,293 S	2/2017	Chen
D475,763 S	6/2003	Kuo		D780,294 S	2/2017	Chen
6,644,625 B1	11/2003	Jacobs et al.		D782,005 S	3/2017	Näslund et al.
D501,538 S *	2/2005	Zeng	D23/226	D782,007 S	3/2017	Näslund et al.
D502,533 S	3/2005	Chen		D782,008 S	3/2017	Näslund et al.
D517,645 S	3/2006	Chang		D783,123 S	4/2017	Chen
D522,088 S	5/2006	Roman		D783,125 S	4/2017	Chen
7,124,965 B1	10/2006	Chen		D792,555 S	7/2017	Hung
D534,241 S	12/2006	Wang		D792,944 S	7/2017	Cheng
D548,392 S	8/2007	Lo et al.		D792,945 S	7/2017	Cheng
7,258,285 B1	8/2007	Combs et al.		D792,947 S	7/2017	Hung
D553,713 S	10/2007	Chih		9,707,573 B1	7/2017	Huang
D554,231 S	10/2007	Chih		9,770,731 B1	9/2017	Chen
D554,233 S	10/2007	Chih		D799,001 S	10/2017	Gooden
D557,767 S	12/2007	Chih		D799,002 S	10/2017	Gooden
D557,769 S	12/2007	Chih		D799,007 S	10/2017	Cheng
D558,302 S	12/2007	Chih		D800,254 S	10/2017	Chen
D558,858 S	1/2008	Chih		D800,255 S	10/2017	Chen
D559,353 S	1/2008	Chih		D802,092 S	11/2017	Näslund et al.
D559,354 S	1/2008	Chih		D819,783 S	6/2018	Urry
D564,065 S	3/2008	Yu		D820,953 S *	6/2018	Chen
D569,478 S	5/2008	Cichy et al.		D821,544 S	6/2018	Urry
D576,252 S *	9/2008	Lo	D23/223	D824,486 S	7/2018	Urry
D584,380 S	1/2009	Cheng		D824,487 S	7/2018	Montoya et al.
D584,381 S	1/2009	Hung		D824,488 S	7/2018	Montoya et al.
D585,109 S	1/2009	Cheng		D824,489 S	7/2018	Montoya et al.
D599,433 S	9/2009	Zore		D824,490 S	7/2018	Montoya et al.
D599,884 S	9/2009	Zore		D824,491 S	7/2018	Montoya et al.
D604,389 S	11/2009	Cheng		D824,492 S *	7/2018	Chen
D604,390 S	11/2009	Cheng		D825,716 S	8/2018	Helmsderfer et al.
D604,395 S	11/2009	Zore		D838,340 S	1/2019	Svendsen et al.
D605,251 S	12/2009	Zore		D838,341 S	1/2019	Svendsen et al.
D606,625 S	12/2009	Zore		D838,809 S	1/2019	Svendsen et al.
D606,626 S	12/2009	Zore		D839,384 S	1/2019	Svendsen et al.
D614,729 S	4/2010	Cheng		D839,992 S	2/2019	Svendsen et al.
D648,824 S *	11/2011	Hung	D23/226	10,213,800 B2	2/2019	Chen
D650,044 S	12/2011	Nies et al.		D846,072 S *	4/2019	Pease
D650,045 S	12/2011	Nies et al.		D846,074 S	4/2019	Pease et al.
D677,362 S	3/2013	Christopher		D846,695 S	4/2019	Pease et al.
D678,980 S	3/2013	Nies et al.		D849,889 S	5/2019	Pease et al.
D681,777 S	5/2013	Nies et al.		D851,209 S	6/2019	Cheng
8,496,190 B2	7/2013	Chen		D855,758 S *	8/2019	Chen
D694,360 S	11/2013	Gaetano		D875,212 S *	2/2020	Svendsen
D702,319 S	4/2014	Mammen		D875,213 S *	2/2020	Svendsen
D704,801 S	5/2014	Chen		D876,581 S *	2/2020	Hsieh
D705,898 S	5/2014	Chen		10,610,879 B2	4/2020	Duong et al.
D714,423 S	9/2014	Mammen et al.		D892,271 S *	8/2020	Urry
D714,908 S	10/2014	Mammen et al.		D892,272 S	8/2020	Urry
				D901,635 S *	11/2020	Chen
				D914,137 S	3/2021	Chen
				D917,666 S	4/2021	Urry
				D921,840 S *	6/2021	Chen

(56)

References Cited

U.S. PATENT DOCUMENTS

D923,746	S	*	6/2021	Svendsen	D23/223
D923,750	S	*	6/2021	Zheng	D23/226
D925,002	S	*	7/2021	Lin	D23/226
D926,931	S	*	8/2021	Chen	D23/226
D927,644	S	*	8/2021	Svendsen	D23/223
D928,287	S	*	8/2021	Svendsen	D23/223
D928,288	S	*	8/2021	Svendsen	D23/223
D929,536	S	*	8/2021	Chen	D23/223
D931,413	S	*	9/2021	Chen	D23/226
D931,414	S	*	9/2021	Chen	D23/226
D946,118	S	*	3/2022	Chen	D23/226
D952,796	S	*	5/2022	Svendsen	D23/223
D962,390	S	*	8/2022	Svendsen	D23/223
2005/0237742	A1		10/2005	Wang		
2006/0249599	A1		11/2006	Guo		
2011/0180636	A1		7/2011	Cheng		
2011/0220738	A1		9/2011	Cheng		
2013/0015271	A1		1/2013	Chen		
2014/0054399	A1		2/2014	Hsieh		
2015/0343467	A1		12/2015	Chen		
2016/0263593	A1		9/2016	Keim		
2017/0204978	A1		7/2017	Huang		
2018/0161795	A1		6/2018	Su		

OTHER PUBLICATIONS

Karcher Premium Multi-Functional Spray Gun posted to amazon.com. Available date: Apr. 20, 2016 (site visited May 17, 2021) Available: (Year: 2016).

Orbit 8-Pattern Nozzle posted to www.lowes.com. Available date: Feb. 16, 2015 (site visited May 17, 2021) Available: (Year: 2015).

* cited by examiner

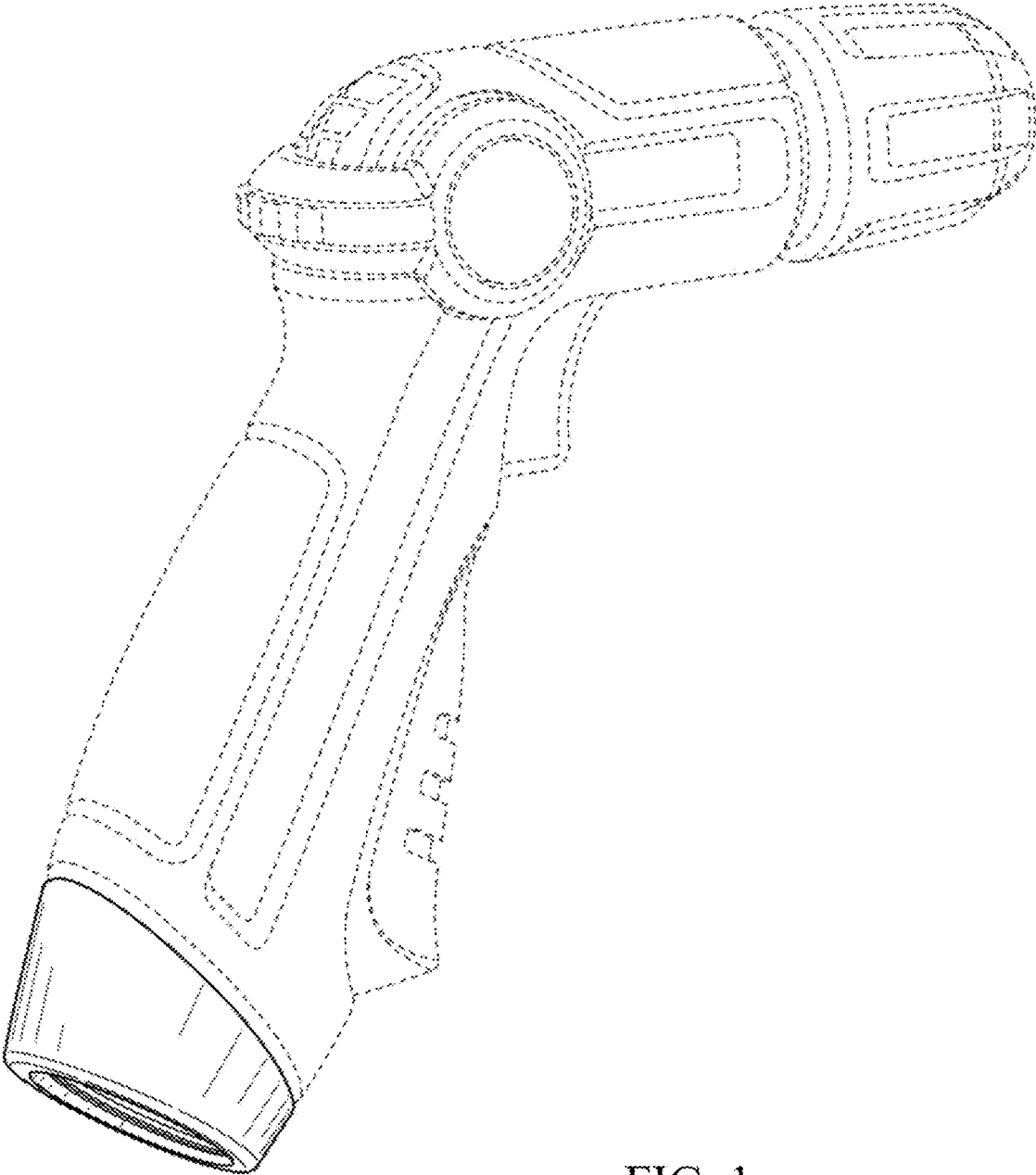

FIG. 1

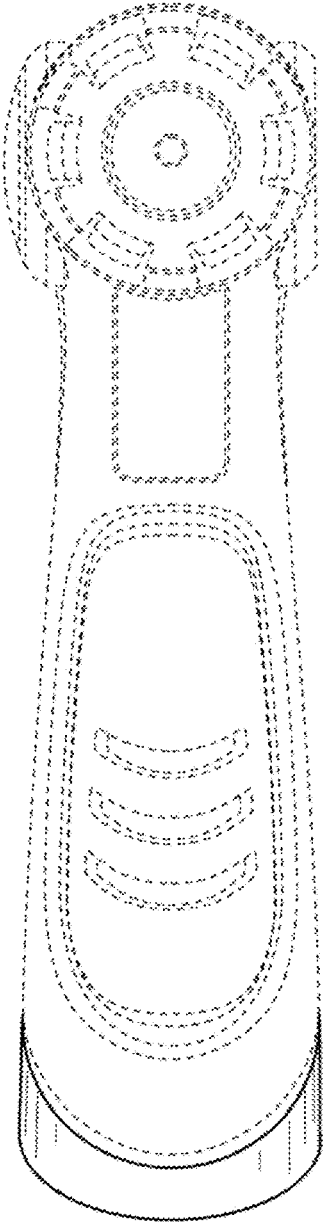

FIG. 2

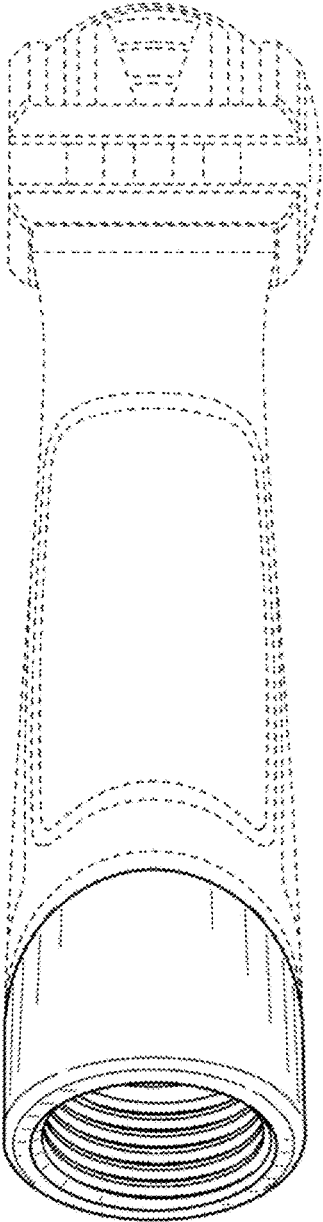

FIG. 3

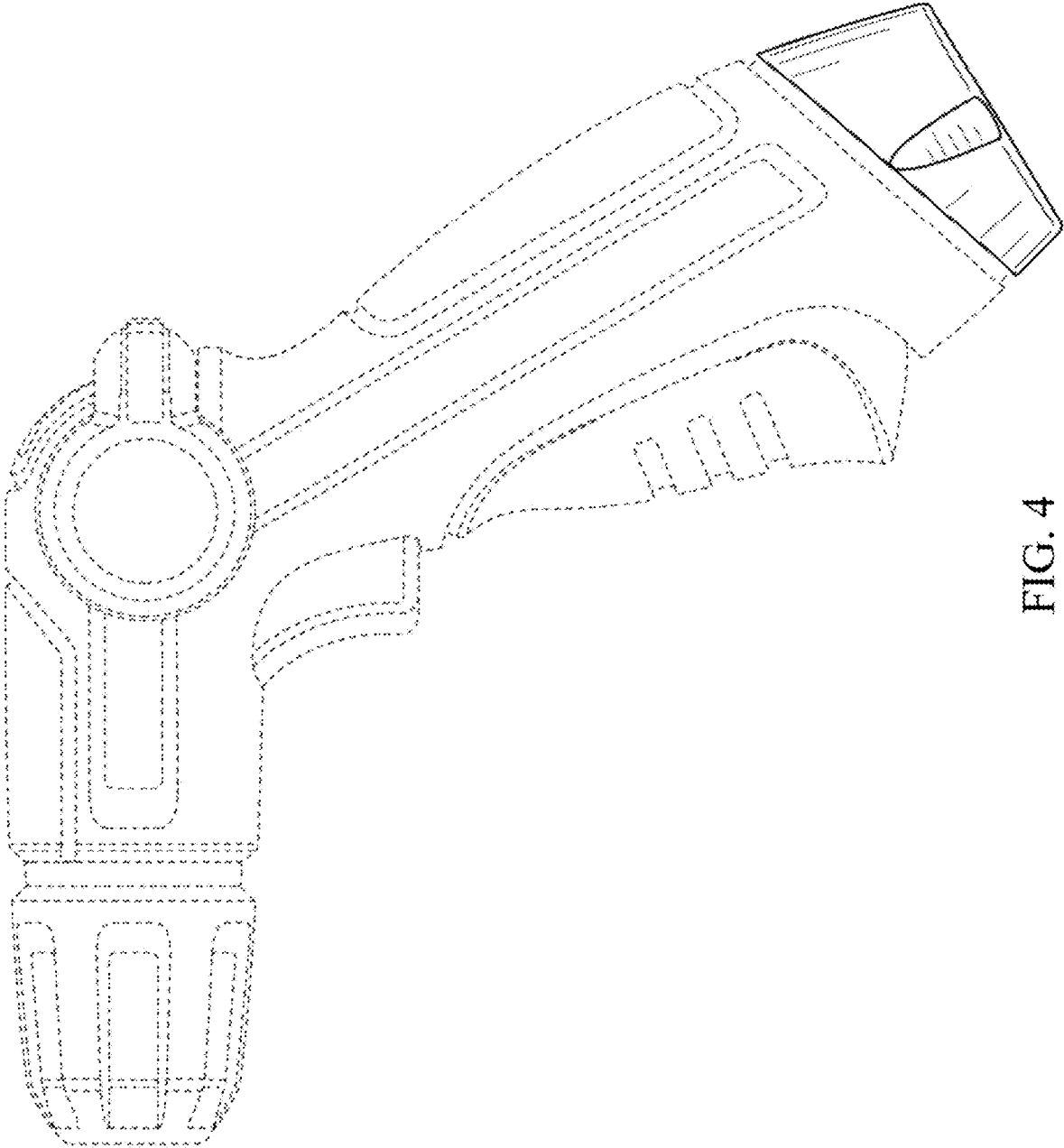

FIG. 4

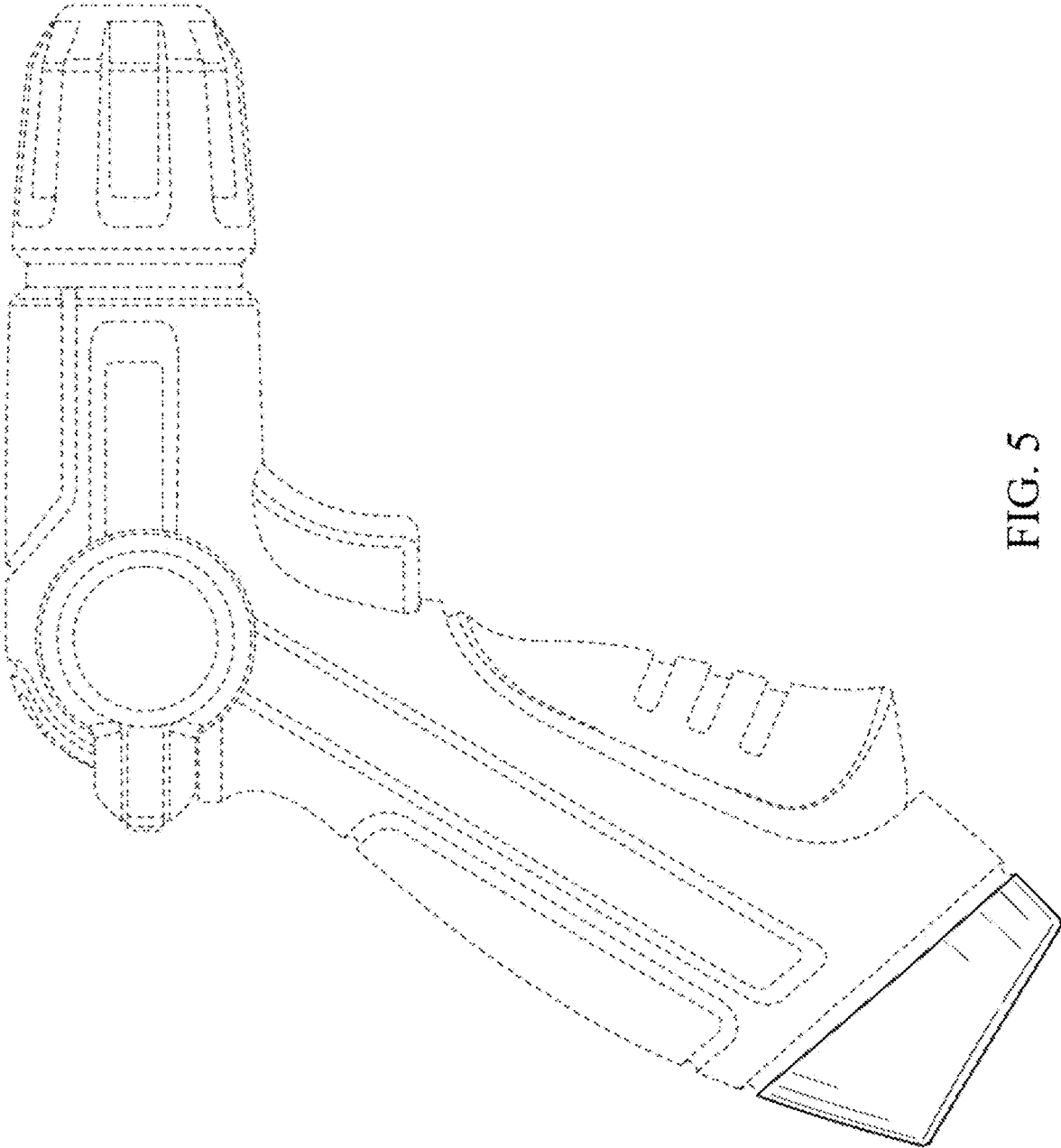

FIG. 5

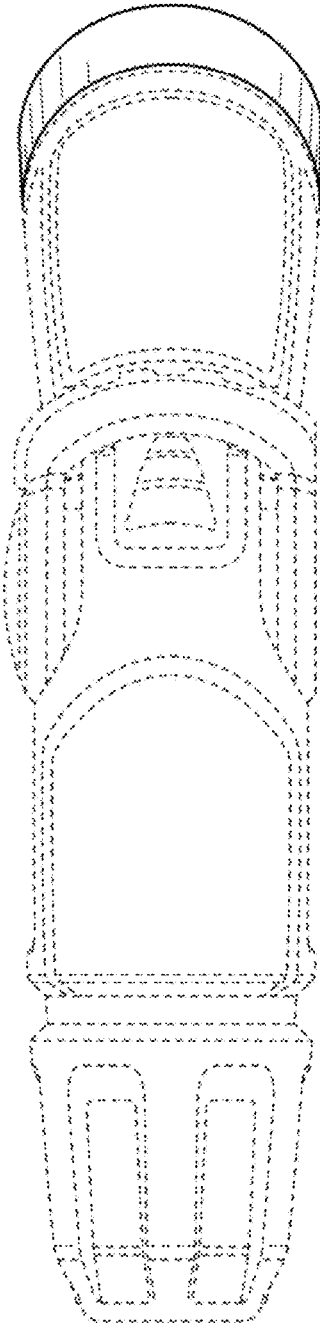

FIG. 6

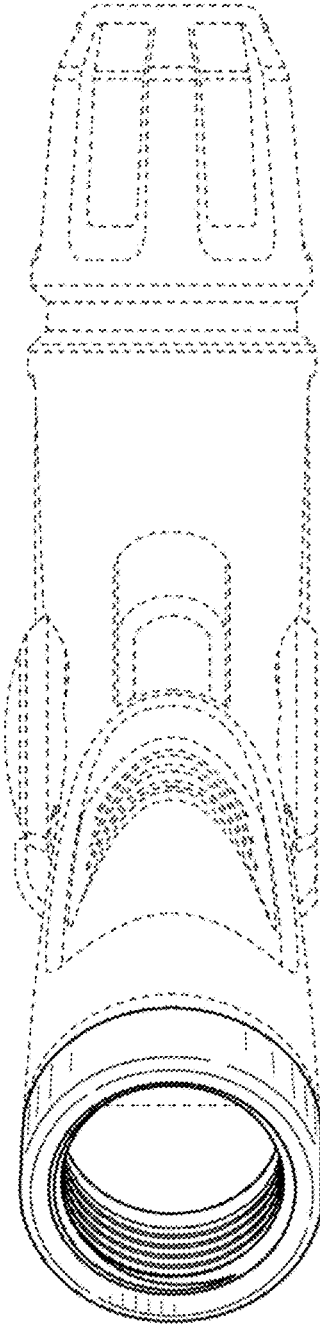

FIG. 7

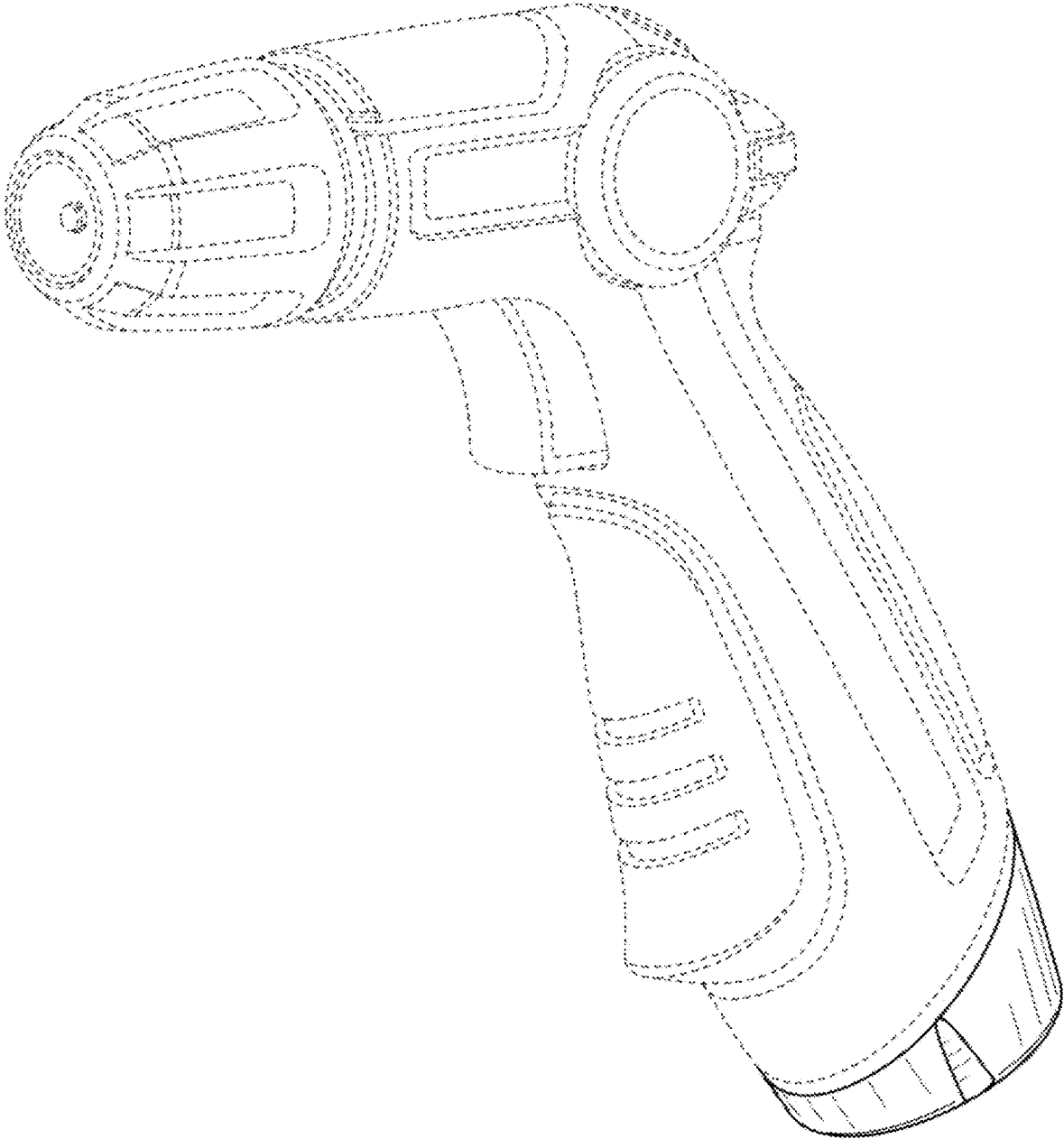

FIG. 8