

Nov. 19, 1968

R. BUCHER

3,411,547

WEFT THREAD SUPPLY APPARATUS FOR LOOMS

Filed Sept. 22, 1966

2 Sheets-Sheet 1

Fig. 1

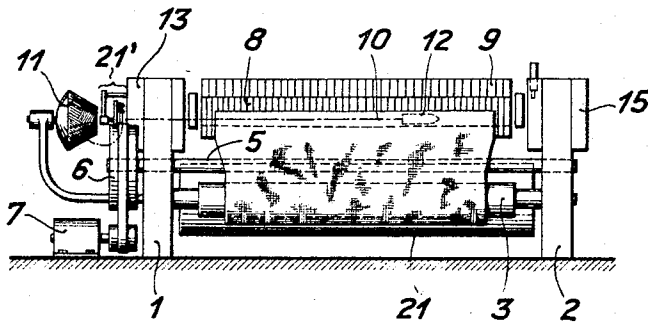

**Inventor:**  
Robert Bucher  
BY *Bennie Edmonds*  
*Morton, Taylor and Alden*  
ATTORNEYS

Nov. 19, 1968

R. BUCHER

3,411,547

WEFT THREAD SUPPLY APPARATUS FOR LOOMS

Filed Sept. 22, 1966

2 Sheets-Sheet 2

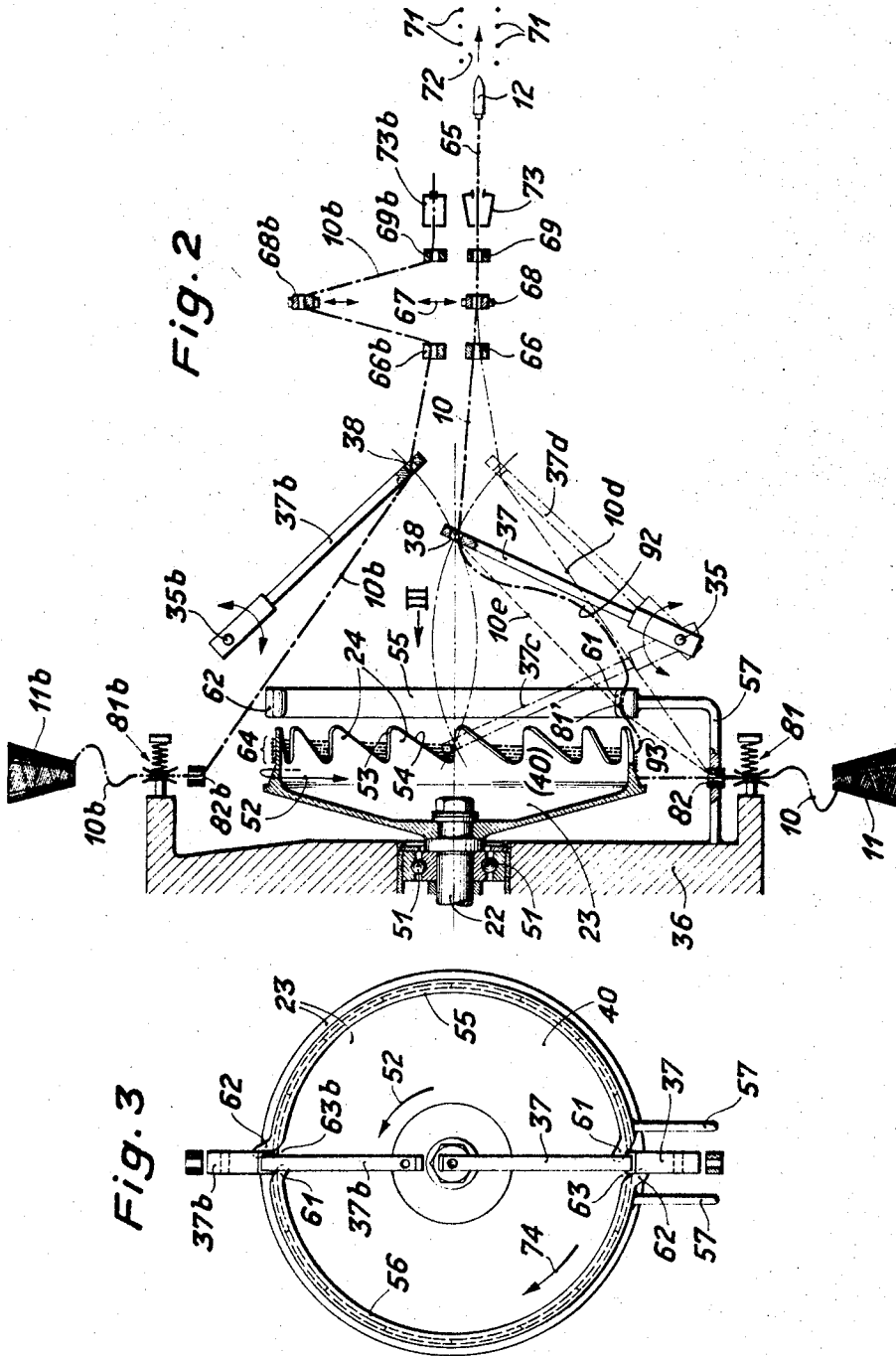

Inventor:  
Robert Bucher  
BY *Pennie, Edmonds,  
Morton, Taylor and Adams*  
ATTORNEYS

1

3,411,547

WEFT THREAD SUPPLY APPARATUS  
FOR LOOMSRobert Bucher, Winterthur, Switzerland, assignor to  
Sulzer Brothers Limited, Winterthur, Switzerland, a  
Swiss Company

Filed Sept. 22, 1966, Ser. No. 581,226

Claims priority, application Switzerland, Oct. 6, 1965,  
13,753/65

3 Claims. (Cl. 139—122)

## ABSTRACT OF THE DISCLOSURE

There is disclosed an intermediate weft thread storage apparatus for looms of the type in which the weft supply bobbin remains outside the shed. This storage apparatus includes a rotatable winder having a ring-shaped array of axially extending fingers and at least two pairs of thread eyes, one eye of each pair being fixed and the other being movably supported on a lever to be movable between a first position in which a thread stretched between the two eyes will be engaged by the fingers of the winder, a second position in which such a thread is clear of the winder, and a third position in which such a thread is moreover outside a split ring supported coaxially of the winder to limit the thread balloon formed when thread wound up on the winder is pulled off thereof. The ring is split adjacent each of the movable eyes to permit operation successively with wefts from separate bobbins.

The present invention relates to looms of the kind employing a weft bobbin which remains outside the shed during picking. According to the present invention, a loom of this type includes a weft preparation system for preparing a length of weft for picking. This system comprises a rotatable winder having a ring-shaped array of axially extending fingers and at least one control lever which has a weft thread guide and which can be tilted in synchronism with the picking operation, alternately into the space defined by the fingers and out again. By means of this lever the weft thread is held inside the space for winding and outside it for drawing off over one end of the winder. The system further comprises an annular or substantially annular member coaxial with the winder and having approximately the diameter of the ring-shaped array of fingers for controlling a thread balloon when the stored weft thread is drawn off the winder during picking.

The balloon control ring, as it may for convenience be called, is particularly advantageous with weft preparation systems having winders with relatively large diameters and high speeds of rotation, since if such systems have no thread balloon control ring a relatively large thread balloon may be produced during picking and in a thread balloon of large diameter and high speed of rotation the weft thread may be highly stressed and may even break. However in accordance with the invention the ring controls the balloon and the weft thread is subjected to practically no centrifugal force in the area where it is drawn off the winder.

In one form of the invention, the thread balloon control ring is positioned immediately in front of the ends of the fingers of the winder over which the weft thread is drawn off. A small balloon of thread therefore remains during unwinding, facilitating removal of the yarn from the winder but stressing the yarn only minimally.

In a construction according to the invention having more than one control lever for multi-weft operation, the thread balloon control ring may have a gap, i.e. be split, adjacent each such control lever to permit the weft thread controlled by that lever to be introduced into the inside

2

of the ring for winding and picking and to permit that thread to be taken outside the ring while the other weft thread or threads are wound and picked. Preferably, the portions of the inner surface of the balloon control member adjacent each gap are respectively turned-in and turned-out so that the portion reached first by weft thread spinning around the surface in the unwinding direction is turned-in and the portion following the gap is turned-out. Thus with multi-weft operation only the weft thread required for the next pick is introduced into the thread balloon control ring and is wound onto the winder. During picking the stored yarn is unwound again. At first it remains inside the balloon control ring, but at the end of picking it can be passed out again through the gap in the ring so that it is no longer within range of the winder. Another thread, e.g. a yarn of a different color, can now be introduced into the balloon control ring by means of a second control lever and wound onto the winder for the next pick.

The invention will now be further described by way of an exemplary embodiment with reference to the accompanying drawings, in which:

FIG. 1 is a diagrammatic general view of a loom incorporating one embodiment of the invention, the loom being seen from the cloth end;

FIG. 2 is a vertical section through part of the loom of FIG. 1, partly in elevation and partly diagrammatic; and FIG. 3 is a corresponding front view of the essential parts in FIG. 2, i.e. looking in the direction of the arrow III in FIG. 2.

Referring to FIG. 1, the loom has two side frames 1 and 2, a cross member 5 between them, a cloth beam 3, a warp beam 21, a reed 8, shafts 9, a picking motion 13 and a catching motion 15 for the shuttle 12, and a drive 7, 6. The weft preparation system 21' is mounted on the picking motion.

Referring to FIG. 2, a shaft 22 is rotatably mounted in ball bearings 51 in a support portion 36 of the main frame of the loom. The shaft shown at 22 in FIG. 2 may be mounted on the loom of FIG. 1 to be parallel to the cloth beam 3 and to the shuttle flight path 10 thereof. An overhung store winder wheel 23 is attached to the right-hand end of the shaft as viewed in FIG. 2. A drive (not shown), e.g. a belt drive, coupled to the loom drive 7, 6, rotates the shaft 22 and the wheel 23 in the direction of arrow 52 in FIG. 3. The winder wheel has saw-tooth-shaped catching and winding fingers 24 arranged so that a thread guided between the fingers is engaged by the tooth flanks 53 which are perpendicular to the direction of rotation, while the diagonal flanks 54 follow the flanks 53.

A short distance, e.g. between one and five millimeters, in front of the winder wheel 23 there is a thread balloon control ring made of two substantially semi-circular portions 55 and 56 attached to separate support posts 57 (FIG. 3). In front of the ring there are two control levers 37 and 37b which contain thread eyes 38 and which turn on stationary pivots 35 and 35b on the loom frame.

Each of the portions 55 and 56 of the thread balloon control ring has a radially turned-in end 61 and a radially turned-out end 62. Between each pair of adjacent ends 61 and 62 there is a gap, 63 or 63b, approximately equal to the thickness of the levers 37 and 37b. The arrangement shown in FIGS. 2 and 3 is designed for operation with two weft yarns by way of example.

The loom operates as follows. FIG. 2 shows the situation when a sufficient length of weft thread 10 for one pick has been wound onto the store wheel 23 from the weft supply bobbin 11 (which may be stationary) outside the shed 72. The length stored forms a coil 64. The coil is produced by the control lever 37 moving temporarily into the space 40 radially and axially inside the fingers 24, i.e. upon tilting of the lever into the position shown

for it at 37c. As a result of this motion of the lever, the thread 10 moves between two catching and winding fingers 24, is caught and is carried by the flank 53 of one of the fingers in the direction of the arrow 52. Yarn is drawn off the bobbin 11 and forms the coil 64.

During picking the lever 37 assumes the position shown in solid lines in FIG. 2 so that its thread eye 38 is approximately in the line of picking 65. The thread passes through a thread brake 81, eyes 82, 38 and 66, a thread tensioning device 68 movable up and down as indicated by an arrow 67, then through an eye 69 and a thread feed and return device 73 to the gripper shuttle 12. A picking device drives the shuttle into the shed 72. The whole of the coil 64 is wound off over the free end of the store wheel 23, in a direction of thread rotation 74 (FIG. 3) opposite to the direction of wheel rotation 52. The store wheel continues to turn in the direction of the arrow 52.

As long as thread winds off the coil 64 in the direction of the arrow 74, it slides, due to centrifugal force, on the inside surfaces of the ring portions 55 and 56, jumping the gaps 63, 63b because of the turned-in ends 61 preceding the gaps. Thus the yarn remains inside the balloon control ring made up of parts 55 and 56. FIG. 2 shows at 81' the position of the yarn as it jumps the gap 63. Towards the end of picking the whole coil 64 has been used and the correct length of yarn has been picked into the shed 72.

Towards the end of the picking operation and after the wound length 64 has been used, the weft thread 10 is slightly tensioned by means of the brake 81 whereas the lever 37 is tilted into the position 37d. Since the unwinding movement is over and the thread is being drawn directly from the bobbin 11, it slips through the gap 63 to position 10d, lever 37 being aligned with the gap 63 circumferentially of the shaft 22 and balloon control ring 55, 56. The shuttle draws a short length of weft thread directly from the bobbin 11 along the line 10d outside the balloon control ring, and then comes to a stop in the catching motion 15 of the loom.

If, for the next pick, yarn 10b (which may for example be of another color) is to be taken from the bobbin 11b onto the store wheel 23, the control lever 37b is tilted clockwise in FIG. 2 to a position corresponding to that shown at 37c for the lever 37, so that the next coil 64 wound up on the wheel 23 will be taken from the bobbin 11b. For picking, the thread feed device 73b is brought into the picking line or axis 75 and the thread tensioning device 68b is moved down so that the thread being picked passes through parts 81b, 82b, eye 38 of lever 37b, 66b, 68b, 69b and 73b to another shuttle (not shown) which draws the thread into the shed 72. At this stage, the control lever 37b is in the picking position, i.e. the position for lever 37b corresponding to the position shown in full lines for lever 37. Towards the end of picking, before the shuttle comes to a stop, the lever 37b is tilted into the inoperative position shown for it in FIG. 2 in which the thread 10b is taut and slips out through the gap 63b in the two-part ring 55, 56 as shown at 10b in FIG. 2.

If thread for several picks is to be prepared on the store wheel 23 from the same bobbin, e.g. bobbin 11, and picked into the shed, the control lever 37 will move only between the winding position shown for it at 37c and the picking position shown for it in full lines. The lever 37 takes up the position indicated at 37d only upon a change of weft thread.

As FIG. 2 shows, there is practically no yarn balloon formed when the stored coil 64 is wound off through the two-part ring 55, 56. The balloon is snubbed at 81 and there is a partial balloon as indicated at 92 between the ring and the eye 38 and also a slight winding-off balloon as indicated at 93 directly adjacent the fingers 24. The winding-off balloon is desirable because it avoids friction on the winding fingers 24. The centrifugal force in both partial balloons 92 and 93 is comparatively small and is

absorbed by the ring 55, 56 so that the weft thread is only slightly tensioned.

In an alternative embodiment of the invention for a loom with single-weft operation, e.g. with only one color of yarn, the balloon control ring 55, 56 may be a continuous ring with no gaps 63, 63b or bent ends 61, 62. The second control lever 37b is then unnecessary, and the lever 37 needs only to be rocked between the winding position indicated at 37c and the picking position shown for the lever 37 in solid lines. At first during picking the weft thread 10 will run on the inside of the continuous balloon control ring. At the end of picking it will take up the position 10e shown with a dashed line in FIG. 2. In doing so it makes a slight detour across the inner edge of the control ring, but this can be accepted.

If the weft store is to be adapted for example for 4-weft operation, there must be four control levers of the type shown at 37, four gaps in the balloon control ring, and four associated pairs of bent ends 61, 62 on the portions of the ring, in contrast to the construction shown in FIGS. 2 and 3. The balloon control ring is then in four portions.

The balloon control ring may be mounted on the loom frame so that it is free to rotate about its own axis, so that it may be drawn around by the spinning weft thread as the thread is drawn off the wheel 23.

The control ring may have a slightly larger diameter relative to wheel 23 than is shown in FIG. 3 and it may to some extent surround the catching and winding fingers 24, i.e. it may be positioned further to the left than is indicated in FIG. 2.

It will thus be seen that the invention provides weft thread supply apparatus for looms. This apparatus comprises a rotatable thread winder 23 having a plurality of axially extending fingers 24, a stationary thread guide such as the guide 81, and a movable thread guide such as the eye 38 on lever 37. This movable thread guide is movable between a first position (that on lever 37 as shown in full lines in FIG. 2) in which a thread extending between those guides is clear of those fingers and a second position (that of eye 38 on lever 37 for the position of lever 37 shown at 37c in FIG. 2) in which a thread extending between those guides is engaged by those fingers upon rotation of the thread winder. The apparatus further comprises, for control of thread ballooning during picking, a substantially annular member positioned coaxially of the thread winder and at a location axially of the winder between the stationary thread guide 81 and the first position of the movable thread guide. In the embodiment illustrated this annular member is made up of two parts 55 and 56, and it is positioned axially of the thread winder 23 beyond the free ends of its fingers 24.

In the presently preferred embodiment of the invention illustrated for plural-weft operation, the apparatus of the invention includes a plurality of pairs of thread guides, one for each type or color of weft thread to be woven. Thus in FIG. 2 guide 81 and the eye 37 of lever 37 make up one pair while guide 81b and the eye 38 of lever 37b make up another pair. Each such pair includes a stationary thread guide and a movable thread guide as defined in the preceding paragraph, and each movable thread guide is additionally movable to a third position in which a thread extending between the stationary thread guide of that pair and that movable thread guide lies outside the annular member. This third position is illustrated, for the pair including guide 81, by the eye 38 on lever 37 in the position of lever 37 shown at 37d. For the pair including guide 81b it is shown by the eye 38 on lever 37b in the single position of lever 37b indicated in the drawing. The annular member is moreover circumferentially split, as at 63 and 63b at a position about the axis thereof adjacent each of the movable thread guides. Preferably moreover, in embodiments in which the annular member is so split, that member includes a

5

portion (as at 61) sloping radially inwardly adjacent each of those gaps, the radially inwardly sloping portion being circumferentially in advance of its gap for motion circumferentially of the annular member opposite to the sense of rotation of the thread winder.

Similarly the annular member may include a portion (as at 62) sloping radially outward on the circumferential side of its gap opposite the radially inwardly sloping portion. Advantageously each movable thread guide is mounted on a lever. While the fingers 24 extend axially, they are not required to have no radial extension.

While the invention has been described above in terms of a presently preferred embodiment, the invention itself is not limited thereto but rather includes all modifications and departures from the embodiment so described and illustrated, properly falling within the spirit and scope of the appended claims.

I claim:

1. Weft thread supply apparatus for looms, said apparatus comprising a rotatable thread winder having a plurality of axially extending fingers, a substantially annular member positioned coaxially of the thread winder, and a plurality of pairs of thread guides, each such pair including a stationary thread guide and a movable thread guide movable between a first position in which a thread extending between the guides of such pair is engaged by said fingers upon rotation of the winder, a second posi-

6

tion in which a thread extending between the guides of such pair is clear of said winder, and a third position in which a thread extending between the guides of such pair is outside said annular member, said annular member being split to form a gap at a position about the axis thereof adjacent each of said movable thread guides.

2. Weft thread supply apparatus according to claim 1 in which said annular member includes a portion sloping radially inwardly adjacent each of said gaps, said portions being circumferentially on the same side of the gap at each of said gaps.

3. Weft thread supply apparatus according to claim 1 wherein said annular member is positioned axially of the thread winder beyond the free ends of said fingers.

#### References Cited

##### UNITED STATES PATENTS

3,276,484	10/1966	Bucher	139—122
3,370,618	2/1968	Svaty et al.	139—122
2,720,223	10/1955	Svaty	139—127
3,280,853	10/1966	Brown et al.	139—122

##### FOREIGN PATENTS

865,729	2/1953	Germany.
1,261,463	4/1961	France.

HENRY S. JAUDON, *Primary Examiner.*