

(19)



(11)

EP 1 790 767 A2

(12)

EUROPEAN PATENT APPLICATION

(43) Date of publication:

30.05.2007 Bulletin 2007/22

(51) Int Cl.:

D06F 57/08 (2006.01)

(21) Application number: **06124541.1**

(22) Date of filing: **22.11.2006**

(84) Designated Contracting States:

AT BE BG CH CY CZ DE DK EE ES FI FR GB GR HU IE IS IT LI LT LU LV MC NL PL PT RO SE SI SK TR

Designated Extension States:

AL BA HR MK YU

(71) Applicant: **GIMI S.p.A.**

35043 Monselice PD (IT)

(72) Inventor: **Miola, Adriano**

35024, BOVOLENTA PD (IT)

(74) Representative: **Modiano, Micaela Nadia**

Dr. Modiano & Associati SpA

Via Meravigli 16

20123 Milano (IT)

(30) Priority: **28.11.2005 IT PD20050096**

(54) **Clothes drying hanger**

(57) A clothes drying hanger (10), of the type comprising a quadrangular frame structure (11) constituted by two longitudinal members (12) and two opposite crossmembers (13), between which rod-like components (14) are arranged which form, together with the quadrangular frame structure (11), a single rack (15) for hanging

clothes which can be extended in the longitudinal direction of the rod-like components (14); stiffening crossmembers (31a) are associated with the legs (16). The clothes drying hanger (10) further comprises means (40) for quick engagement/disengagement to respective portions (18a) of the supporting legs (16) for at least one of the stiffening crossmembers (31a) of the hanger.

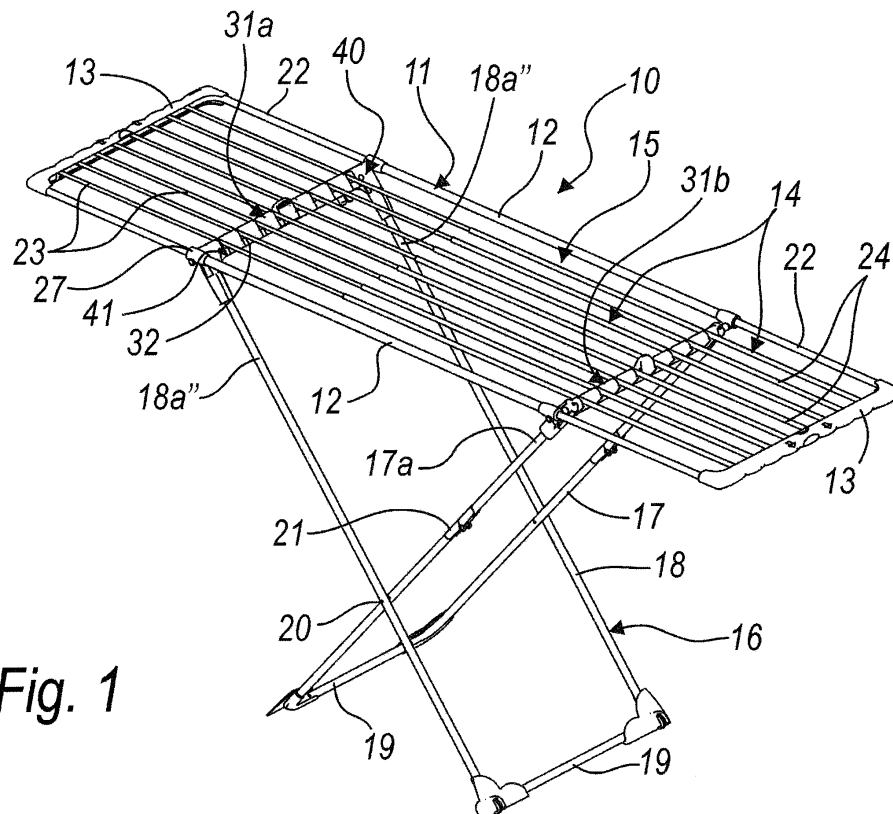

Fig. 1

EP 1 790 767 A2

Description

[0001] The present invention relates to a clothes drying hanger of the type with an extensible clothes hanging rack for hanging clothes.

[0002] Clothes drying hangers are known which are provided with a rack for hanging clothes which can be extended in order to vary the load capacity and adapt it to the space in which the drying hanger is arranged.

[0003] Among these, Italian patent application PD2005U000004, filed by this same Applicant on 11 February 2005, discloses a clothes drying hanger of the type which comprises a quadrangular frame structure constituted by two longitudinal members and two opposite crossmembers, between which rod-like components are arranged which form, together with the quadrangular frame structure, a single rack for hanging clothes which can be extended along the longitudinal direction of said rod-like components; supporting legs which have a scissor-like articulation are coupled to said longitudinal members.

[0004] Two mutually opposite and parallel rod-like portions protrude from the ends of each crossmember and form a U-shaped configuration with the crossmembers.

[0005] Such rod-like portions are coupled slidingly to the longitudinal members; each rod-like component is constituted by two elements which are mutually coupled slidingly and are fixed respectively to a corresponding crossmember.

[0006] One embodiment of such clothes drying hanger further includes a pair of stiffening crossmembers, which connect the ends of the legs; when the clothes drying hanger is open in the active configuration, each rod-like component lies proximate to the stiffening crossmembers.

[0007] This clothes drying hanger solves in an optimum manner the problem of load variability but is not free from drawbacks.

[0008] These drawbacks are linked to the interference of said stiffening crossmembers with respect to the possibility to hang large items of clothing comfortably.

[0009] The aim of the present invention is to provide a clothes drying hanger which is capable of changing its dimensions and therefore its clothes loading capacity in order to optimize the space available but without renouncing the presence of stiffening crossmembers when needed.

[0010] Within this aim, an object of the present invention is to provide a clothes drying hanger which is particularly easy to move when changing configuration.

[0011] Another object of the present invention is to provide a clothes drying hanger which can be manufactured with known systems and technologies.

[0012] This aim and these and other objects, which will become better apparent hereinafter, are achieved by a clothes drying hanger of the type which comprises a quadrangular frame structure constituted by two longitudinal members and two opposite crossmembers, be-

tween which rod-like components are arranged which form, together with said quadrangular frame structure, a single rack for hanging clothes which can be extended in the longitudinal direction of said rod-like components, supporting legs being rigidly coupled to said longitudinal members, a mutually opposite and parallel pair of rod-like portions protruding from the ends of each of said crossmembers and forming, together with said crossmembers, a U-shaped configuration, said rod-like portions being slidingly coupled to said longitudinal members, each rod-like component being constituted by two elements which are mutually coupled slidingly and are fixed respectively to a corresponding said crossmember, said clothes drying hanger further comprising two stiffening crossmembers, each of which connects two corresponding portions of said supporting legs associated with separate longitudinal members, each rod-like component, when the clothes hanger is open in the active configuration, being proximate to said stiffening crossmembers, characterized in that it comprises means for quick engagement/disengagement on said legs for at least one of said stiffening crossmembers.

[0013] Further characteristics and advantages of the invention will become better apparent from the following detailed description of a preferred but not exclusive embodiment thereof, illustrated by way of non-limiting example in the accompanying drawings, wherein:

Figure 1 is a perspective view of a clothes drying hanger according to the invention;

Figure 2 is a perspective view of the clothes drying hanger of Figure 1 with a stiffening crossmember which does not connect respective leg portions;

Figure 3 is a transverse sectional view of the stiffening crossmember proximate to one of its ends, which corresponds to the point of engagement to the corresponding leg portion;

Figure 4 is a transverse sectional view of said stiffening crossmember proximate to the opposite end with respect to Figure 3, at a point for pivoting to the corresponding leg portion.

[0014] It is noted that anything found to be already known during the patenting process is understood not to be claimed and to be the subject of a disclaimer.

[0015] With reference to the figures, a clothes drying hanger according to the invention is generally designated by the reference numeral 10.

[0016] The clothes hanger 10 comprises a quadrangular frame structure 11, which is constituted by two tubular longitudinal members 12 and two mutually opposite crossmembers 13, between which rod-like components 14, which are likewise tubular, are arranged parallel to each other and to the longitudinal members 12.

[0017] The rod-like components 14 form, together with the quadrangular frame structure 11, a single rack 15 for hanging clothes; the rack 15 can be extended in the longitudinal direction of the rod-like components 14, as de-

scribed in greater detail hereinafter (Figure 1 shows in broken lines the direction of elongation of the rack 15).

[0018] Supporting legs 16, for example of the scissor-like type, are pivoted to the tubular longitudinal members 12 substantially at the ends.

[0019] According to a per se known layout, the supporting legs 16 of the scissor-like type are constituted by two separate U-shaped legs, respectively a first U-shaped leg 17 and a second U-shaped leg 18, each of which is pivoted by the ends of the U-shape to corresponding ends of the two tubular longitudinal members 12.

[0020] The horizontal portions 19 of the U-shaped legs 17 and 18 act as a supporting base.

[0021] The first U-shaped leg 17 has, above the point 20 for pivoting with the second U-shaped leg 18, on both arms of the U-shape, respective joints 21 in order to allow 180° folding of the first U-shaped leg 17 in order to allow the collapse of the legs so as to assume a flattened configuration on the quadrangular frame structure 11.

[0022] Two mutually opposite and parallel rod-like portions 22 protrude from the ends of each crossmember 13 and form a U-shape together with the corresponding crossmember 13.

[0023] The rod-like portions 22 are slidingly coupled by insertion in the longitudinal members 12, which, as mentioned, are tubular in this embodiment.

[0024] Each rod-like component 14 is constituted by two elements, respectively a first element 23 and a second element 24, which are mutually coupled slidingly by mutual insertion; in particular, the first element 23, which has a circular cross-section, is inserted in the second element 24, which is tubular.

[0025] Each element 23 and 24 is fixed to a corresponding crossmember 13.

[0026] In this manner it is possible to extend the single rack 15 for hanging clothes; by pulling the crossmembers 13 toward the outside of the rack 15, it is in fact possible to increase the length of the rod-like components 14.

[0027] Each rod-like component 14, being composed of two elements which are coupled slidingly, in practice telescopically, can in fact extend.

[0028] The pivoting of the legs 16 to the longitudinal members 12 occurs by means of a hinge block 27, which is fixed both to the longitudinal members and to the legs.

[0029] The hinge block 27 is constituted for example by a bush made of plastic material, which is keyed at the end to the longitudinal members 12.

[0030] The clothes drying hanger 10 further comprises two stiffening crossmembers 31.

[0031] Each stiffening crossmember 31 connects the ends of each U-shaped leg 17 and 18 substantially proximate to the hinge block 27.

[0032] Each rod-like component 14, when the clothes hanger 10 is open in the active configuration, lies proximate to the stiffening crossmember 31.

[0033] Slots 32 are further formed longitudinally on the stiffening crossmembers 31 in order to accommodate the

rod-like components 14 once the clothes hanger 10 has been arranged in the closed inactive configuration, with the legs 16 flattened onto the frame structure 11.

[0034] As clearly shown in the figures, the stiffening crossmembers 31 connect two corresponding supporting leg portions which are associated with separate longitudinal members 12; in particular, one crossmember 31, termed first crossmember 31 a, is connected between the portions of supporting leg 18a which form the ends of the second U-shaped leg 18, while the other crossmember 31, termed second crossmember 31b, is connected between the portions of supporting leg 17a which form the ends of the first U-shaped leg 17.

[0035] Advantageously, the clothes drying hanger 10 is provided with quick engagement/disengagement means 40 for one of the stiffening crossmembers 31 on the supporting legs 16, so as to provide a rack 15 which is free from transverse obstacles, to be used if it is necessary to hang large items.

[0036] In this embodiment, the quick engagement/disengagement means 40 are associated with the first crossmember 31a.

[0037] It is evident that the quick engagement/disengagement means 40 can be provided also on both of the stiffening crossmembers 31 depending on design requirements.

[0038] The first stiffening crossmember 31a is connected to a respective leg portion 18a' by means of a hinge 41 which is formed at one end, while the means 40 for quick engagement/disengagement (described hereinafter) on the opposite leg portion 18a" are provided at the opposite end.

[0039] The first stiffening crossmember 31 a is arranged, when the quick engagement/disengagement means 40 are in the disengagement configuration, in a configuration in which the rack 15 substantially has no obstacles.

[0040] In particular, the stiffening crossmember 31a can be arranged, when the quick engagement/disengagement means 40 are in the disengagement configuration, along the leg portion 18a' to which it is pivoted, as shown in Figure 2.

[0041] In particular, the axis of the hinge 41 is substantially perpendicular to the plane on which the longitudinal axes of the leg portions 18a' and 18a" are arranged, connected by the stiffening crossmember 31a, which in practice is perpendicular to the plane of arrangement on which the U-shaped configuration of the first leg 17 is arranged.

[0042] The first stiffening crossmember 31 a is provided with means 42 for reversible locking to the leg portion 16 to which it is pivoted, said means being active when the quick engagement/disengagement means 41 are in the disengagement configuration and therefore the stiffening crossmember 31 is arranged along the corresponding second leg portion 18a'.

[0043] The reversible locking means 42 comprise two parallel tabs 43 with an enlarged head, which are elastically deformable and protrude from the face 46 of the

stiffening crossmember 31a which is directed, when the first crossmember 31a is in a configuration in which it substantially does not form an obstacle on the rack 15, toward the leg portion 18a' to which it is pivoted.

[0044] The tabs 43 lie on opposite sides of the leg portion 18a', and lock it; the enlarged heads form an extraction-preventing undercut for the leg portion 18a'.

[0045] The quick engagement/disengagement means 40 are formed at one end of the first stiffening crossmember 31a, the one which lies opposite the hinge 41.

[0046] It is evident that in other embodiments, not shown, the quick engagement/disengagement means can be associated with both ends of the first crossmember 31a, making it completely disengageable from the supporting structure of the clothes drying hanger.

[0047] In this embodiment, the quick engagement/disengagement means 40 comprise a coupling which is formed by a retention body 47, which is elastically flexible and is suitable to mate with a corresponding locking seat 48.

[0048] The elastically flexible retention body 47 is arranged at the end of the first stiffening crossmember 31a, while the corresponding locking seat 48 is formed on the corresponding leg portion 18a'.

[0049] The ends of the leg portions 18a' and 18a" are fitted on corresponding identical bushes 34 made of plastic material; the hinge blocks 27 of the longitudinal members 12 are pivoted on said bushes.

[0050] A cradle 49 for accommodating the end of the first stiffening crossmember 31a, on which the retention body 47 is provided, is formed on the bush 34 related to the leg portion 18a'.

[0051] The cradle 49 is provided with two mutually opposite walls 50, in one of which there is a through hole which forms the locking seat 48 for the retention body 47.

[0052] The end portion 47a of the retention body 47, when it is in the engagement configuration, protrudes from the through hole which forms the locking seat 48 and can be available as a release button to a user.

[0053] In particular, the retention body 47 is constituted by a ring 51 made of elastically deformable plastic material, which is arranged within a compartment 52 formed inside the first stiffening crossmember 31a.

[0054] The ring is locked between the two mutually opposite walls 50 of the cradle 49; a stud protrudes from a circumferential external position of the ring 51 and forms the end portion 47a, which can be inserted in the locking seat 47.

[0055] An additional cradle 53 for the end of the first stiffening crossmember 31a associated with the hinge 41 is provided on the bush 34 related to the pivoting end of the stiffening crossmember 31a.

[0056] Two coaxial through holes 54 are provided in the additional cradle 53 and are suitable to define the hinge seats for coaxial pivot-like studs 55, which protrude laterally from the first stiffening crossmember 31a.

[0057] In practice it has been found that the invention thus described achieves the intended aim and objects.

[0058] In particular, the present invention provides a clothes drying hanger which allows to use stiffening crossmembers when it is not necessary to have the rack completely free of transfers obstacles and to remove them easily (just one or both, depending on design choices) when it is necessary to have the rack completely free.

[0059] In practice, the materials used, so long as they are compatible with the specific use, as well as the dimensions, may be any according to requirements and to the state of the art.

[0060] The disclosures in Italian Utility Model Application No. PD2005U000096 from which this application claims priority are incorporated herein by reference.

[0061] Where technical features mentioned in any claim are followed by reference signs, those reference signs have been included for the sole purpose of increasing the intelligibility of the claims and accordingly such reference signs do not have any limiting effect on the interpretation of each element identified by way of example by such reference signs.

Claims

1. A clothes drying hanger, of the type comprising a quadrangular frame structure (11) constituted by two longitudinal members (12) and two opposite crossmembers (13), between which rod-like components (14) are arranged which form, together with said quadrangular frame structure (11), a single rack (15) for hanging clothes which can be extended in the longitudinal direction of said rod-like components (14), supporting legs (16) being rigidly coupled to said longitudinal members (12), a mutually opposite and parallel pair of rod-like portions (22) protruding from the ends of each of said crossmembers (13) and forming, together with said crossmembers (13), a U-shaped configuration, said rod-like portions (22) being slidingly coupled to said longitudinal members (12), each rod-like component (14) being constituted by two elements (23) which are mutually coupled slidingly and are fixed respectively to a corresponding said crossmember (13), said clothes drying hanger further comprising two stiffening crossmembers (31), each of which connects two corresponding portions of said supporting legs (18a', 18a'') associated with separate longitudinal members, each rod-like component (14), when the clothes hanger (10) is open in the active configuration, being proximate to said stiffening crossmembers (31), **characterized in that** it comprises means (40) for quick engagement/disengagement on said supporting leg portions (18a) for at least one of said stiffening crossmembers (31a).
2. The clothes drying hanger according to claim 1, **characterized in that** the at least one said stiffening crossmember (31a) with which said quick engage-

- ment/disengagement means (40) are associated is connected to a respective said leg portion (18a') by means of a hinge (41) which is formed at one end, while at the opposite end there are said means (40) for quick engagement/disengagement on the opposite leg portion (18a"), said at least one stiffening crossmember (31a) being arranged, when said quick engagement/disengagement means (40) are in the disengagement configuration, in a configuration in which they substantially do not form an obstacle of said rack (15).
3. The clothes drying hanger according to claim 2, **characterized in that** said at least one stiffening crossmember (31a) can be arranged, when said quick engagement/disengagement means (40) are in the disengagement configuration, along the leg portion (18a') to which it is pivoted.
 4. The clothes drying hanger according to claim 3, **characterized in that** said at least one stiffening crossmember (31a) has means (42) for reversible locking to the leg portion (18a') to which it is pivoted, said means being active when said quick engagement/disengagement means (40) are in the disengagement configuration.
 5. The clothes drying hanger according to claim 4, **characterized in that** said reversible locking means (40) comprise two parallel tabs (43) which have an enlarged head, are elastically deformable and protrude from the face (46) of said at least one stiffening crossmember (31a) which is directed, when it is in the configuration for substantially not forming an obstacle on the rack (15), toward the leg portion (18a') to which it is pivoted, said tabs (43) being arranged on opposite sides of said leg portion (18a'), locking thereon, said enlarged heads forming an extraction-preventing undercut.
 6. The clothes drying hanger according to one or more of the preceding claims, **characterized in that** the axis of said hinge (41) is substantially perpendicular to the plane on which the longitudinal axes of the leg portions (18a) connected by said at least one stiffening crossmember (31a) are arranged.
 7. The clothes drying hanger according to one or more of the preceding claims, **characterized in that** said quick engagement-disengagement means (40) are formed at at least one end of a corresponding said stiffening crossmember (31a) and comprise a coupling which is formed by at least one retention body (47), which is elastically flexible and is suitable to mate with a corresponding locking seat (48).
 8. The clothes drying hanger according to claim 7, **characterized in that** said at least one retention body (47) is arranged at the end of said at least one stiffening crossmember (31a), while said corresponding locking seat (48) is formed on the corresponding leg portion (18a").
 9. The clothes drying hanger according to claim 8, **characterized in that** it comprises a cradle (49) for accommodating the end of said at least one stiffening crossmember (31a) on which said at least one retention body (47) is provided, said cradle being formed monolithically with a bush (34) in which the end of the corresponding leg portion (18a") is stably inserted and the corresponding longitudinal member (12) is pivoted, said cradle (49) having two mutually opposite walls (50), on at least one of which there is a through hole which forms a said locking seat (48) for said elastically flexible retention body (47), the end portion (47a) of said mutually opposite retention body (47) protruding from said through hole when in the engagement configuration and being available as a button to a user.
 10. The clothes drying hanger according to claim 9, **characterized in that** said retention body (47) is constituted by an elastically deformable ring (51), which is arranged inside a compartment (52) which is formed inside said at least one stiffening crossmember (31a), said ring (51) being locked between said mutually opposite walls (50) of said cradle (49), a stud protruding from an external circumferential position of said ring (51) and forming the end portion (47a) which can be inserted in said locking seat (47).
 11. The clothes drying hanger according to the preceding claim, **characterized in that** it comprises an additional cradle (53) for the end of said at least one stiffening crossmember (31a) which is associated with said hinge (41), said additional cradle (53) being formed by an identical bush on which the end of the respective leg (18a') is fitted stably, two coaxial through holes (54) being provided in said additional cradle (53) and being suitable to form the hinge seats for coaxial pivot-shaped studs (55) which protrude from said at least one stiffening crossmember (31a).

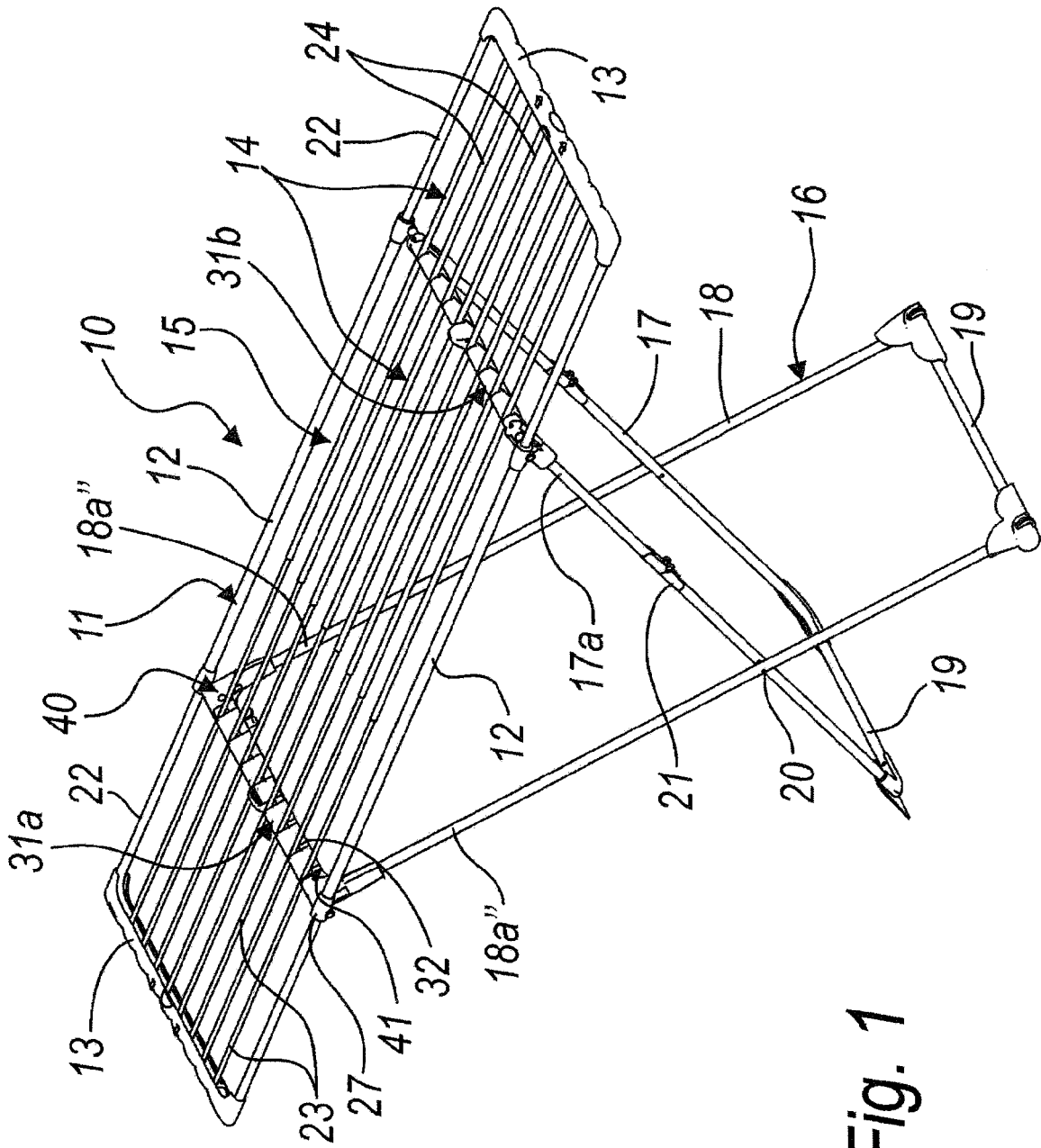

Fig. 1

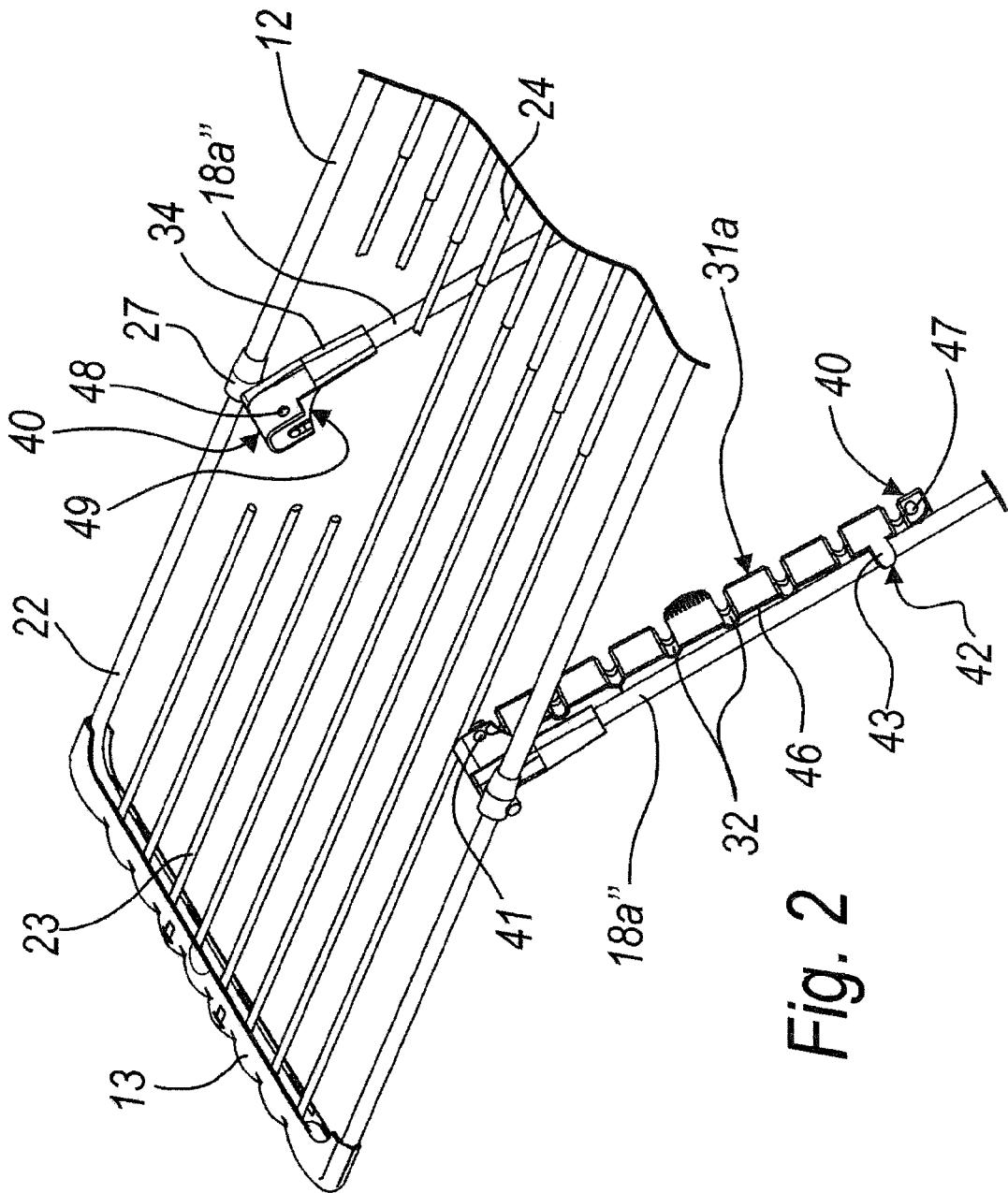

Fig. 2

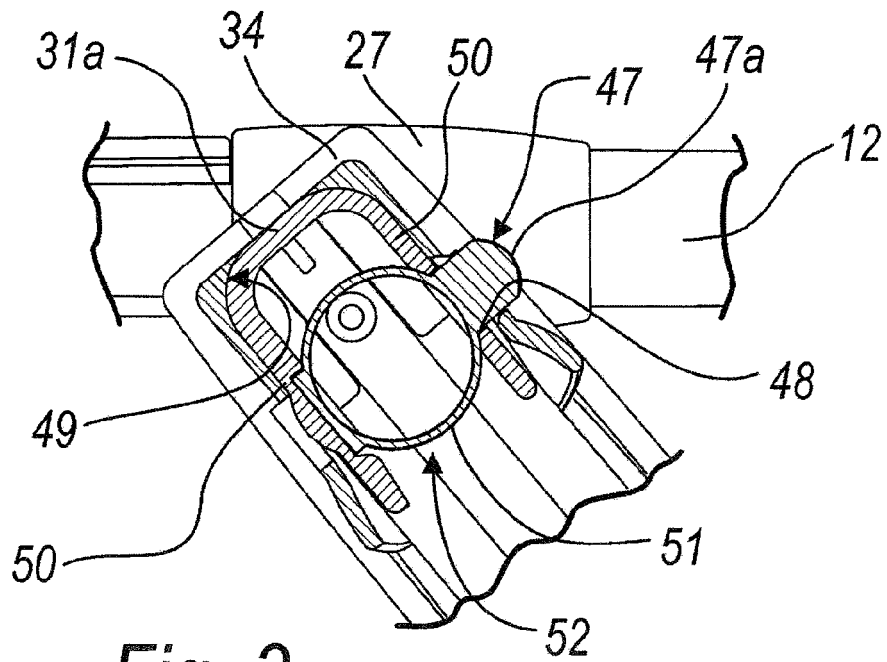

Fig. 3

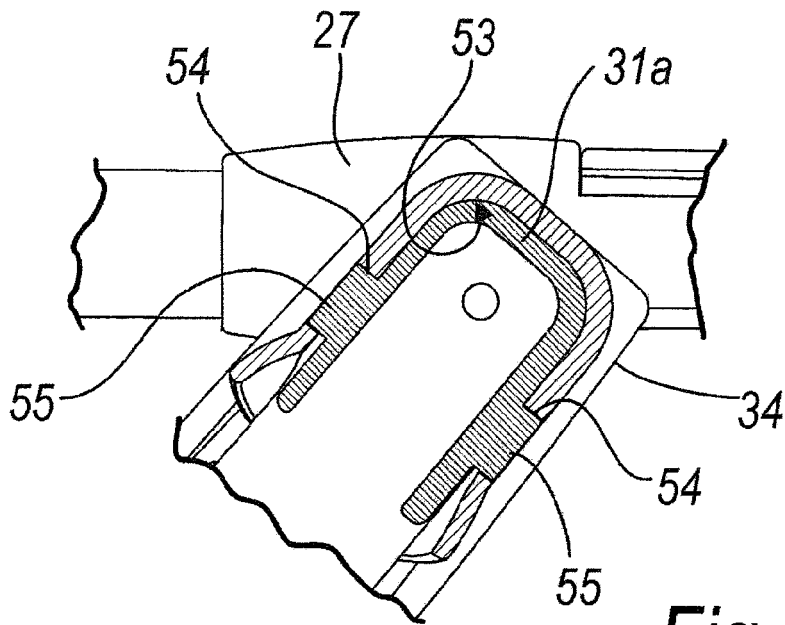

Fig. 4

REFERENCES CITED IN THE DESCRIPTION

This list of references cited by the applicant is for the reader's convenience only. It does not form part of the European patent document. Even though great care has been taken in compiling the references, errors or omissions cannot be excluded and the EPO disclaims all liability in this regard.

Patent documents cited in the description

- IT PD20050004 U [0003]
- IT PD20050096 U [0060]