

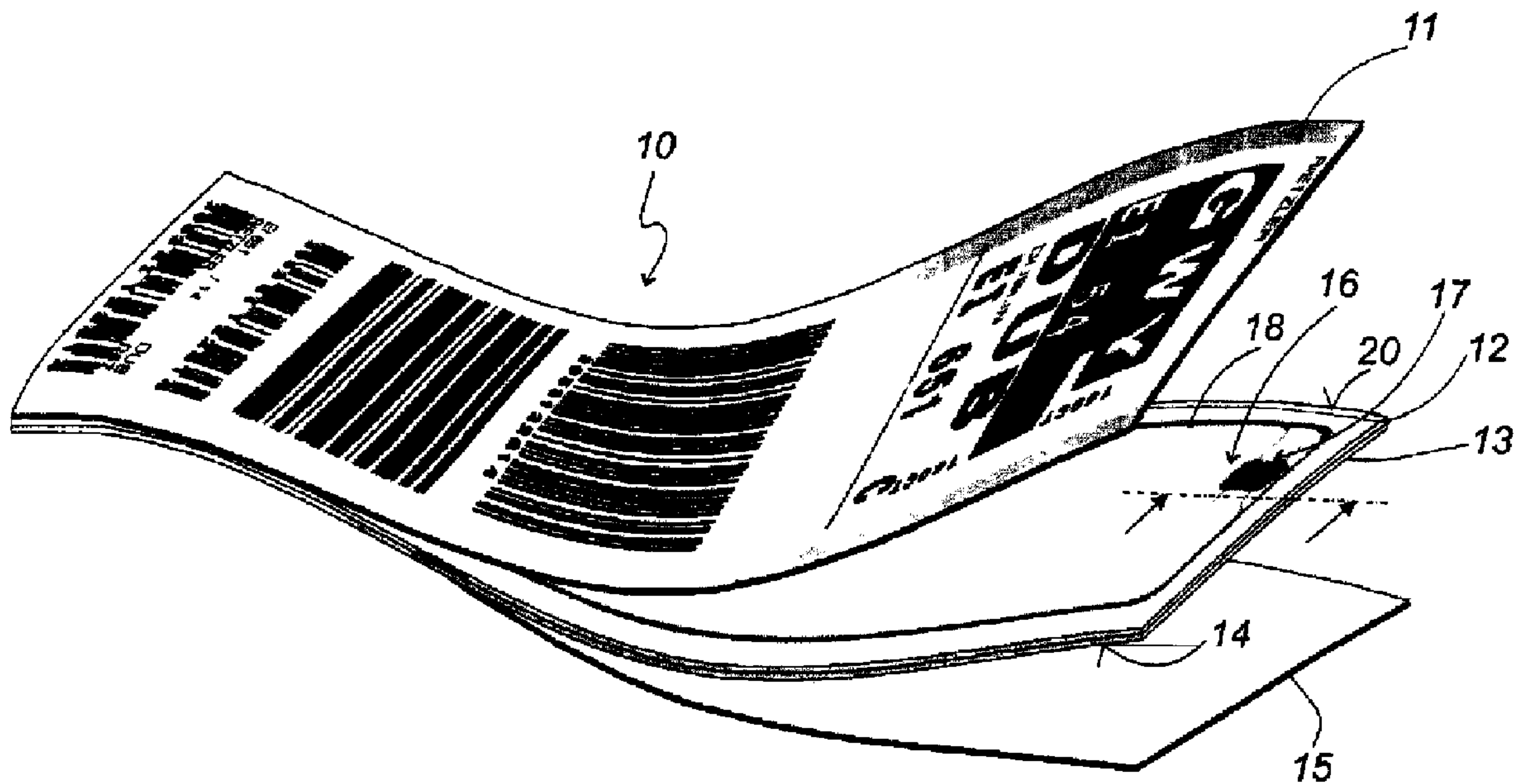

(86) Date de dépôt PCT/PCT Filing Date: 1999/10/28  
 (87) Date publication PCT/PCT Publication Date: 2000/05/11  
 (45) Date de délivrance/Issue Date: 2006/02/14  
 (85) Entrée phase nationale/National Entry: 2001/05/02  
 (86) N° demande PCT/PCT Application No.: DE 1999/003448  
 (87) N° publication PCT/PCT Publication No.: 2000/026855  
 (30) Priorité/Priority: 1998/11/02 (198 50 353.9) DE

(51) Cl.Int./Int.Cl. *G06K 19/077* (2006.01),  
*H04B 1/59* (2006.01), *G09F 3/02* (2006.01),  
*G01V 15/00* (2006.01)  
 (72) Inventeurs/Inventors:  
 FINN, DAVID, DE;  
 RIETZLER, MANFRED, DE  
 (73) Propriétaires/Owners:  
 FINN, DAVID, DE;  
 RIETZLER, MANFRED, DE  
 (74) Agent: OGILVY RENAULT LLP/S.E.N.C.R.L.,S.R.L.

(54) Titre : ETIQUETTE D'IDENTIFICATION ET PROCEDE DE PRODUCTION D'UNE ETIQUETTE D'IDENTIFICATION  
 (54) Title: IDENTIFICATION LABEL AND PROCESS FOR PRODUCING AN IDENTIFICATION LABEL



(57) **Abrégé/Abstract:**

The invention relates to an identification label (10) to be fastened on the surface or around articles. Said identification label has a multi-layer structure with an identification layer (11) for optically labeling, a reinforcement layer (12) for mechanically stabilizing the identification layer and an adhesive layer (13) for fastening the identification label on the article. The reinforcement layer serves as the substrate for arranging thereon a transponder unit (16).

### **Abstract**

The invention relates to an identification label (10) to be fastened on the surface or around articles. Said identification label has a multi-layer structure with an identification layer (11) for optically labeling, a reinforcement layer (12) for mechanically stabilizing the identification layer and an adhesive layer (13) for fastening the identification label on the article. The reinforcement layer serves as the substrate for arranging thereon a transponder unit (16).

## **Identification Label and Process for Producing an Identification Label**

5

The present invention relates to an identification label with a transponder unit for surface mounting on or for mounting around an object provided with a multi-layered layer structure with an identification layer for optical marking, a reinforcement layer for mechanical stabilization of the identification layer and an adhesion layer for mounting the identification label on the object. Furthermore, the invention relates to a process for producing such an identification label as well as additionally a base unit for producing the identification label.

15

Identification labels of the type mentioned in the outset are generally embodied as so-called „self-adhesive labels“ for marking objects. A particularly large range of use is the field of luggage identification of airfreight parcels. Here, labels are used which are provided with an essentially three-layered structure in the applied state, namely one identification layer, oriented visibly outwards for the purpose of the primary identification of the corresponding luggage parcel which is provided with an optical marking, a reinforcement layer which serves as a carrier layer for the identification layer and its mechanical stabilization, and finally an adhesion layer which enables an adhesive mounting to the luggage parcel when contacting the surface of the corresponding luggage parcel.

20  
25

The particular advantage of the known identification labels consists in their flexible nature, which enables an application of the labels not only on plane surfaces but on sharply curved surfaces as well, such as handles, for example.

In order to enable a touchless identification of the luggage parcels provided with the identification labels even at greater distances, in addition to an optical marking on the exterior identification layer of the identification label by means of so-called „bar-codes“ and alphanumeric markings, it is desirable to combine the identification labels known per se with so-called transponder units which enable a touchless access to the information stored in a chip unit of the transponder unit. The chip unit contacts an antenna coil and forms the transponder unit together therewith. For this purpose, the chip unit and the antenna coil are positioned on a common transponder substrate. Attempts to combine such a transponder unit with an identification label known per se for creating an overall identification label that allows an electronic marking in addition to an optical marking lead to an overall label structure in which a conventional identification label is supplemented with a transponder unit provided on the transponder substrate. Thus, an additional layer was added to the multi-layered layer structure of the conventional identification layer in form of the substrate of the transponder unit. However, this change of the overall layer structure of the identification label results in disadvantages regarding the thickness and the flexibility of identification labels of such nature.

In EP-A-0 595 549 an identification label with a transponder and marking is known with the transponder provided on a transponder substrate being combined with a conventional identification label.

2a

The invention is therefore based on the object to create an identification label improved in its functionality by means of a transponder unit without disadvantageous modifications to the layer structure of the identification label.

This object is attained in an identification label with the characteristics of claim 1.

In the identification label according to the invention the reinforcement layer serves as a substrate for arranging the transponder unit. The functional expanse of an identification label with an electronic marking, allowed by the transponder unit, without changing the layer structure of the identification label is enabled by using the reinforcement layer,

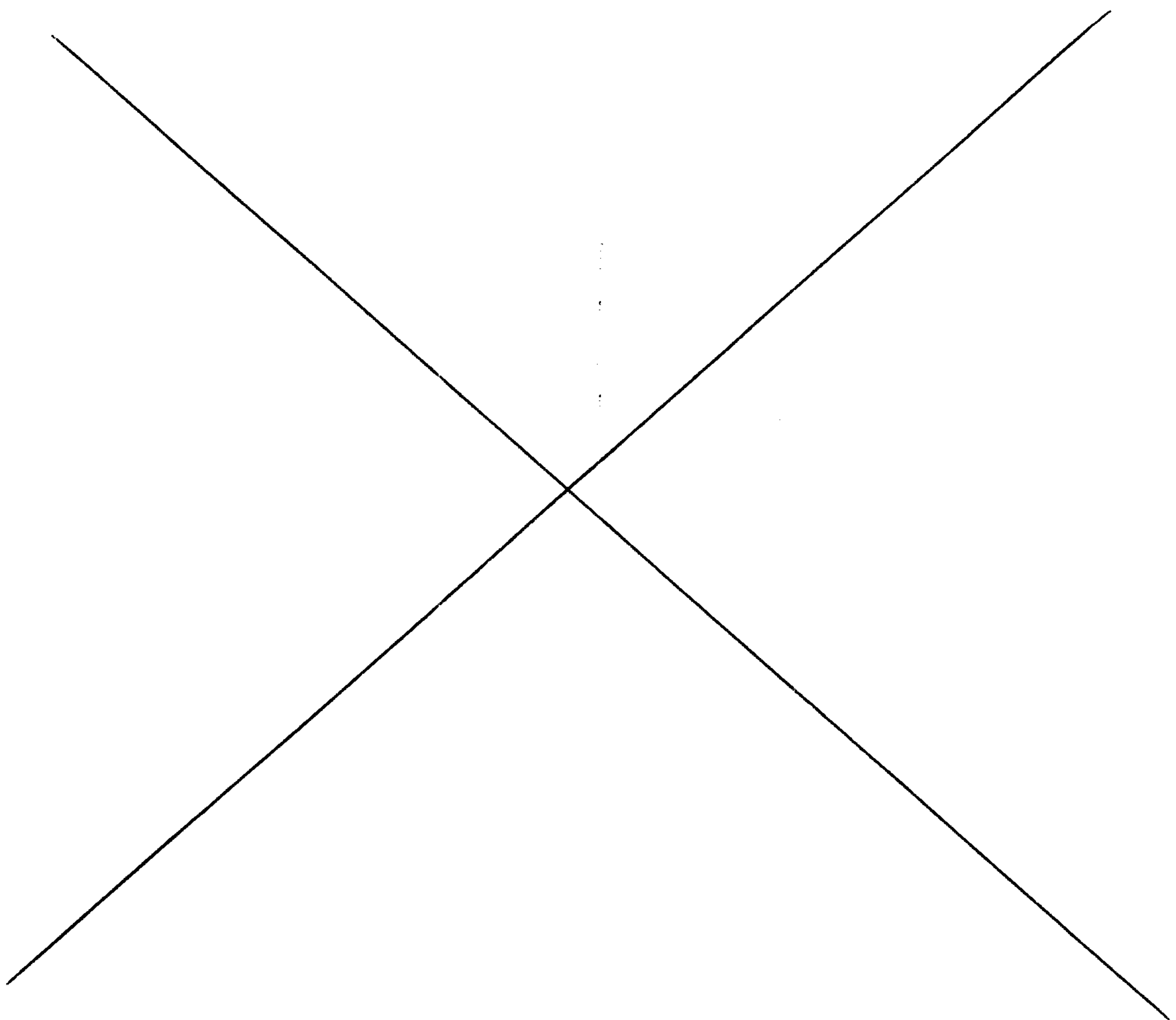

already provided in the layered structure of conventional identification labels, as a substrate for arranging the transponder unit. Thereby, the flexible and almost unlimited application of the identification label onto objects, which specifically recommends the use of identification labels, is unobstructed in spite of the integration of a transponder unit in the layer structure. Therefore, a separate substrate for arranging the transponder unit can be omitted which would change the mechanical and geometrical characteristics of the layer structure of the identification label.

10 It has been proven particularly advantageous for the transponder unit to extend in a boundary layer between the reinforcement layer and the adhesion layer since, thereby, the adhesion layer serves the purpose of covering the transponder unit in a leveling fashion, in particular, in case of the transponder unit being applied essentially superficially onto the reinforcement layer. Thus, it is possible to use processes which lead to an antenna coil which is rather embedded in the reinforcement layer as well as processes which rather lead to a surface application of the antenna coil, in particular, for creating and/or applying the antenna coil of the transponder unit, with the respective selection of the process for the creation and/or application of the antenna coil depending on the nature of the material of the reinforcement layer as well, i.e., whether the reinforcement layer allows at least a partial embedding of the antenna coil or only a surface application of the antenna coil.

25 In order to allow another type of mounting the identification label the adhesion layer can be covered with a deadening layer and the reinforcement layer can be provided with a mounting device, for example a mounting tape, for mounting the identification label onto an object.

30 The object the invention is based upon is also attained in a base unit for producing an identification label with the characteristics of claim 4.

The base unit according to the invention for producing an identification unit for surface mounting on or for mounting around an object serves as the base for the further layer structure in the production of an identification label and includes a reinforcement layer and an adhesion layer with the reinforcement layer serving as the substrate for arranging a transponder unit in a boundary layer embodied between the reinforcement layer and the adhesion layer.

The base unit according to the invention allows providing a semi-finished product in the process of producing an identification label. Here, the semi-finished product is already provided with a transponder unit and shows a layer structure, which is part of the overall layer structure of conventional identification labels as well. Originating in the base unit according to the invention, the further production steps for finishing identification labels, known from the production of conventional identification labels, can occur in an unchanged manner in the production of an identification label according to the invention. Therefore, the base unit according to the invention offers the advantageous possibility for the producer of identification labels to maintain his process for processing and applying the exterior identification layer and his customary process for coding the exterior identification layer unchanged subsequent to the introduction of the base unit into his production process for producing identification labels.

It proves particularly advantageous for a mostly integrated arrangement of the transponder unit in the reinforcement layer to provide the reinforcement layer with a window opening for an at least proportional acceptance of a chip unit and the chip unit being in contact with an antenna coil made of wire for the embodiment of the transponder unit. On the one hand, the window opening allows a largely sunken arrangement of the chip unit in the reinforcement layer, and, on the other hand, the condition of the antenna coil made of wire offers the possibility to

arrange also the antenna coil by means of a suitable pressure effect at least proportionally sunken in the reinforcement layer. Hereby, overall the portion of the transponder unit projecting from the surface of the reinforcement layer is kept small so that even a very thin-layered  
5 embodiment of the adhesion layer is sufficient to cover the transponder unit in a leveling fashion.

Additional window openings in the reinforcement layer have been proven advantageous for contacting the contact ends of the antenna coil by  
10 accessing the contact regions of the chip unit.

It has also proven advantageous to surround the chip unit at least partially with a stiffening device extending in the level of the reinforcement layer in order to keep adverse mechanical pressures away  
15 from the chip unit during the production of the layer structure.

However, depending on the nature of the material of the reinforcement layer it is possible as well to provide the antenna coil made of wire on the surface of the reinforcement layer and to cover the antenna coil by a  
20 rather thick-layered embodiment of the adhesion layer in a leveling fashion.

In order to exclude the accidental adhesion of the adhesion layer of the base unit when the base unit is placed at disposal for further use in the  
25 production process for producing identification labels the possibility exists to cover the adhesion surface of the adhesion layer with a deadening layer. This deadening layer can be embodied, e. g. by a silicon paper layer applied onto the adhesion layer and easily removable therefrom.

30

The deadening layer can be embodied in the clear surface of the reinforcement layer of another base unit as well, at least while the base



unit is placed at disposal for the subsequent use in the production of an identification label. A deadening layer embodied in such a fashion simultaneously provides a secure, temporarily stacked compound of a multitude of base units prior to their separation and utilization in the production process for producing an identification label.

An additional solution of the object the invention is based upon consists in performing a process according to claim 12 in which, initially, a base unit is placed at disposal according to one or more of the claims 4 through 11 and, subsequently, an identification label is applied onto the base unit.

Therefore, the process according to the invention provides for the production of an identification label based on a previously produced base unit so that the producer of identification labels based on the base unit is able to produce an identification label which allows an optical as well as an electronic marking without the production process becoming more complex for the producer of identification labels than in the production of known conventional identification labels which allow only an optical marking.

Depending on the type of the construction of the identification layer the identification layer can be applied directly on the base unit or subsequently to a previous application of an intermediate layer as a carrier layer for the identification layer. A paper layer can be used as the carrier layer, for example.

For producing an adhesion between the base unit and the identification layer or the carrier layer a permanent adhesion layer can be applied onto the base unit, the identification layer, or the carrier layer. Instead of the permanent adhesion layer another adhesion layer can be provided next to the initial adhesion layer as well.

It has proven particularly advantageous when, in a common process at the end of the production process for producing the identification labels, the coding of the exterior identification layer as well as the coding of the transponder unit and/or the chip unit of the transponder unit occurs in a common coding process. Thus, identification labels can be produced in a particularly easy and economical fashion which enables the recognition of identification data by means of an optical reader, based on the coding of the exterior identification layer, as well as the recognition of stored chip data by means of an electronic reader. Identification labels of such nature can equally be used in cooperation with optical and electronic reading devices, depending on equipment standard.

In the following, an embodiment of the identification label according to the invention and a modification therefrom for producing the identification label according to the process according to the invention is described in detail with the help of the drawings. They show:

Fig. 1. an embodiment of an identification label with an exterior identification layer and a transponder unit;

Fig. 2 a partial sectional representation of the identification label shown in Fig. 1 with the particular representation of a base unit;

Fig. 3 the base unit shown in Fig. 2 having a permanent adhesion layer;

Fig. 4 an identification layer with a transponder unit integrated into a conventional layer structure according to an initial embodiment;

Fig. 5 a conventional identification label according to prior art;

Fig. 6 another identification label with a modified configuration of the transponder unit;

5

Fig. 7 a base unit with a reinforcement layer provided between two adhesion layers.

Fig. 1 shows an identification label 10 with an exterior identification layer 11 which is applied onto a reinforcement layer 12 for the purpose of mechanically stabilizing the identification layer 11. On the bottom of the reinforcement layer 12 an adhesion layer 13 is provided formed from an adhesive glue application, which adhesion layer is connected tightly adhered to the bottom of the reinforcement layer 12. The adhesion layer 13 is provided with an adhesion surface 14 which is provided with a deadening layer 15 for deadening, i.e., for preventing the adhesion to a surface.

In order to better represent the separate layers of the layer structure the identification label 10 shown in Fig.1 is shown in partially delaminated layers, i.e., separated from one another in partial regions, i.e., the identification layer 11, the reinforcement layer 12 with the adhesion layer 13 adhering thereto, and the deadening layer 15.

However, the left half of the identification label 10 shown in Fig. 1 is provided with a closed layer compound with separate layers, arranged directly on top of one another, in a manner equivalent to the original state of the identification label 10 prior to the separation of the deadening layer 15 from the adhesion layer 13 for application onto a surface of an object to be marked, not shown in detail here.

30

As discernible from the layer structure of the identification label 10 shown in Fig. 1 in a partially delaminated state the reinforcement layer 12 serves the purpose not only to be a mechanical stabilizer for the identification label 10 and/or the identification layer 11 but also simultaneously to be a substrate for arranging a transponder unit 16 as well. In the present case, the transponder unit 16 includes a chip unit, embodied here as the chip module 17, and an antenna coil 18 contacting the chip module 17, in the present case produced of copper wire.

In Fig. 1, for better showing the arrangement of the transponder unit 16 on the reinforcement layer 12 serving as a substrate, the reinforcement layer 12 is shown consisting of a transparent material. For additional description of the arrangement of the transponder unit 16 on the reinforcement layer 12, Fig. 2 shows an enlarged partial sectional representation of the reinforcement layer 12 with the deadening layer 15 being in adhesive contact with the adhesion layer 13 embodied on the bottom of the reinforcement layer 12 in the representation according to Fig. 2. The layer compound, shown in Fig. 2, between the reinforcement layer 12 and the adhesion layer 13 applied to the bottom of the reinforcement layer 12 forms a base unit 19 which forms the identification label 10, supplemented by the identification layer 11 for forming the identification label 10 shown in Fig. 1. Here, in forming the identification layer 11 made of a material directly laminable onto a base material, the identification layer 11 can be applied directly onto the upper structure surface 20 of the reinforcement layer 12 for forming the identification layer 10, for example under the influence of pressure and temperature, as in the case of the identification label 10 shown in Fig. 1.

The base and mounting unit 19, shown in Fig. 2, and formed from a layered compound of the reinforcement layer 12 and the adhesion layer 13, is provided with the transponder unit 16 in the region of a boundary layer 21 embodied between the reinforcement layer 12 and the adhesion

layer 13. The chip module 17 having a chip and/or the form corpus 22, accepting the chip and called „mould“ by those trained in the art, is inserted into a window opening 23 of the reinforcement layer 12 in order to enable a sunken acceptance of the chip module 17. Here, a contact carrier 24 of the chip module 17 serves, in addition to a restricting arrangement of the chip module 17 to an application surface 25 of the reinforcement layer 12, to contact the free contact ends 26, 27 of the antenna coil 18 made of coil wire 28. As further discernible from Fig. 2, the antenna coil 18, created by laying onto the application surface 25 of the reinforcement layer 12, for instance, is positioned embedded in the application surface 25 so that all other regions or parts of the transponder unit 16 are essentially positioned in the reinforcement layer 12, except the contact carrier 24 of the chip module 17 which contacts the contact ends 26, 27 via bumps 30, 31 provided on its contact side 29. This results in an adhesion layer 13 being sufficient even in a comparatively thin-layered embodiment applied on the application surface 25 of the reinforcement layer 12, in order to completely cover the transponder unit 16 and/or the contact carrier 24 of the chip module 17 with the formation of a level adhesion surface 14 of the adhesion layer 13. In the present case, a silicon paper serves as the deadening layer 15 for deadening the adhesion surface 14 of the adhesion layer 13. For activating the adhesion surface 14 the deadening layer 15 can easily be pulled off.

Fig. 3 shows the base unit 19 at the beginning of the process for producing an identification label 32 shown in Fig. 4, also being shown in a partially sectional representation. The base unit 19 shown in Fig. 3 serves as the semi-finished product for the production of the identification label 32, i.e., as an intermediate product previously produced in an independent process, which is used as a unit for the purpose of the production of the identification label 32, i.e., as a layer of the overall layer structure to be produced. For creating the overall layer structure 36, shown in Fig. 4, forming the identification label 32,

initially the structure surface 20 is provided with a permanent adhesion layer 33 which can be embodied as a hot-melt layer, for example, and which can be evenly distributed over the structure surface 20 of the reinforcement layer 12 by means of blade coating. Here, the free space 34  
5 remaining after the insertion of the chip module 17 into the window opening 23 is at least partially filled with the adhesion material of the permanent adhesion layer 33.

Fig. 4 shows the further structure of the layers. Comparing the layer  
10 structure shown in Fig. 5 to a corresponding conventional identification label 35 according to prior art it is obvious that, in the present case, the layer structure 36 of the conventional identification label 35, which is only provided with an exterior identification layer 11, is identical with the layer structure 36 of the embodiment of the identification label 32  
15 according to the invention, shown in Fig. 4, which is provided with the transponder unit 16 in addition to the exterior identification layer 11. As Fig. 4 clearly shows, the transponder unit 16 is essentially provided in the boundary layer 21 between the reinforcement layer 12 and the adhesion layer 13 without influencing the overall layer structure 36  
20 thereby.

The further layers of the overall layer structure 36, built onto the permanent adhesion layer 33, concern a paper layer 37, an adhesion layer 38 for producing an adhering connection to the identification layer 11, in  
25 the present case embodied as a so-called „thermo-layer“, for example, and a sealing layer 39 which serves as the surface protection for the identification layer 11.

The identification label 32 shown in Fig. 4 is provided with the  
30 advantageous possibility, due to its overall layer structure being identical to the overall layer structure 36 of conventional identification labels 35, to be able to mark or code the exterior identification layer 11 after the

production of the overall layer structure 36 in a thermoprinting process. An essential reason is here that, due to keeping the customary overall layer structure 36 in spite of the transponder unit 16 positioned in the overall layer structure 36, an overall thickness is allowed which enables a conventional printing of the identification label 32 in a thermoprinting process without any problems.

Fig. 6 shows a representation of an identification label 40, identical to the type of representation in Fig. 4, which is embodied identically in its overall layer structure 36 with the identification layer 32 shown in Fig. 4. Unlike the identification layer 32, the identification layer 40 is provided with a differently configured transponder unit 41, with the transponder unit 41 still being positioned in the boundary layer 21 between the reinforcement layer 12 and the adhesion layer 13, however, as discernible from a comparison of the Figs. 4 and 6. Unlike the identification label 32, the transponder unit 41 and/or an antenna coil 42 contacting the transponder unit 41 via the chip module 17 is not embedded in the material of the reinforcement layer 12 but rather positioned on the application surface 25 of the reinforcement layer 12. The difference in arranging the antenna coil 42 of the identification label 40 compared to arranging the antenna coil 18 of the identification label 32 can be caused by the type of process used for applying the antenna coil 42 as well as the material of the reinforcement layer 12, which for example does not allow embedding. However, in any case the antenna coil 42 is covered by the adhesion layer 13 in forming a leveled adhesion layer 14 so that here the overall layer structure 36 is maintained as well, in particular the layer structure of the base unit 19.

As further discernible from Fig. 6, the reinforcement layer 12 is provided with a window opening 43 adjusted to the neighboring contours of the form corpus 22 of the chip module 17. Additionally, in the present case the form corpus 22 is adjusted in its height  $h$  to the thickness  $d$  of the

reinforcement layer 12 so that essentially no clear space remains in the window opening 43 and overall an essentially level structure surface 20 of the reinforcement layer 12 and/or the base unit 19 results.

5 With regard to the material selection for the reinforcement layer 12 the use of polypropylene has proven particularly advantageous since here a particularly easy embedding of the antenna coil 18 is possible, as shown in the exemplary embodiment of the identification label 32 in Fig. 4. As discernible from Fig. 6 and from the descriptions related to Fig. 6  
10 respectively, corresponding material characteristics are not necessary, though, since even a rather superficial application of the antenna coil 42 onto the application surface 25 of the reinforcement layer 12 is possible just as well, without thereby influencing the overall layer structure 36. Thus, any material can be selected for the reinforcement layer 12 as long  
15 as the initial mechanically stabilizing function of the reinforcement layer 12 remains.

Although not shown in detail here, it is also possible to use transponder units in which the antenna coil and/or the contact ends of the antenna coil  
20 directly contact the chip, for example in directly providing the chip contact surfaces with bumps for contacting the contact ends of the antenna coil, unlike the transponder units 16 and/or 41 shown in Figs. 4 and 6 and which each relate to a chip module 17 in contact with an antenna coil 18 or 42 respectively. Therefore, in such an embodiment of  
25 the transponder unit the contact carrier 24 of the chip module 17 is omitted. However, it can be advantageous for a transponder unit produced in a direct connection of the chip to the antenna coil to provide a separate reinforcement device, peripherally surrounding the chip, which keeps adverse mechanical stresses away from the chip during the production of  
30 the layer structure, for example in the lamination process. However, such reinforcement devices can be advantageous for the utilization of the chip module 17 shown by way of example in Figs. 4 and 6 as well, in order to



protect the chip provided in the form corpus 22. Fig. 4 shows, outlined in a dot-dash pattern, the possible exemplary embodiment of a reinforcement device embodied here as a ring-shaped support bush 44. For installing the support bush 44, it is inserted into the window opening 5 23, as indicated in Fig. 4, prior to the insertion of the form corpus 22 of the chip module 17.

Unlike the base unit 19 shown in Fig. 3 which is provided with a permanent adhesion layer 33, Fig. 7 shows a base unit 45 with a 10 reinforcement layer 46 which is provided on its structural surface 20 with a second adhesion layer 47, which can be identical in its composition to the adhesion layer 13 and which like the adhesion layer 13 can be embodied by an adhesive glue layer.

15 As further shown in Fig. 7, in addition to a window opening 48 for accepting the form corpus 22 of the chip module 17 surrounding the chip, the reinforcement layer 46 is provided with two additional window openings 49, 50 which allow a contacting access to the contact ends 26, 27 of the antenna coil 18 embedded in the reinforcement layer 46 during 20 the construction of the base unit 45. Hereby, subsequently to the embedding of the antenna coil 18 and prior to the application of the adhesion layers 13, 47 onto the reinforcement layer 46 the chip module 17 is applied onto the application surface 25 of the reinforcement layer 46, simultaneously inserting the form corpus 22 into the window opening 25 48. Through the window openings 49, 50 the contact ends 26, 27 of the antenna coil 18 can be accessed in the region of the contact surfaces 51, 52 on the contact side 29 of the contact carrier 24 of the chip module 17 so that contacting the contact ends 26, 27 is possible by the contact surfaces 51, 52 from above, where the structure surface 20 of the 30 reinforcement layer 46 is arranged, by means of suitable bonding tools, not depicted in detail here. Subsequently, the adhesion layers 13 and 47 are applied onto the structural surface 20 and the application surface 25

of the reinforcement layer 46. Here, the adhesive glue material used for the construction of adhesion layers 13, 47 can be used for leveling unevenness and at least partially filling hollow spaces.

- 5 The base unit 45 provided with another adhesion layer 47, shown in Fig. 7, can be modified into a „transponder tag“ in a most easy fashion by applying deadening layers, here not shown in detail, which also allow a mounting onto objects with mounting means, such as tape or the like.

**Claims**

- 5 1. An identification label with a transponder unit for surface  
mounting on or mounting around an object provided with a multi-  
layered layer structure with an identification layer for optical  
marking, a reinforcement layer for mechanical stabilization of the  
10 identification layer, and an adhesion layer for mounting the  
identification label on the object, characterized in that the  
reinforcement layer (12, 46) serves as a substrate for arranging the  
transponder unit (16, 41).
- 15 2. An identification label according to claim 1, characterized in that  
the transponder unit (16, 41) extends in a boundary layer (21)  
formed between the reinforcement layer (12, 46) and the adhesion  
layer (13).
- 20 3. An identification label according to claim 1 or 2, characterized in  
that the adhesion layer (13) is covered with a deadening layer (15)  
and the reinforcement layer (12, 46) is provided with a  
reinforcement device for mounting the identification label onto the  
object.
- 25 4. A base unit as a semi-finished product for producing an  
identification label with a transponder unit for surface mounting on  
or for mounting around an object, including a reinforcement layer  
and an adhesion layer, characterized in that the reinforcement layer  
(12, 46) serves as a substrate for arranging the transponder unit  
30 (16, 41) in a boundary layer (21) formed between the reinforcement  
layer (12, 46) and the adhesion layer (13).

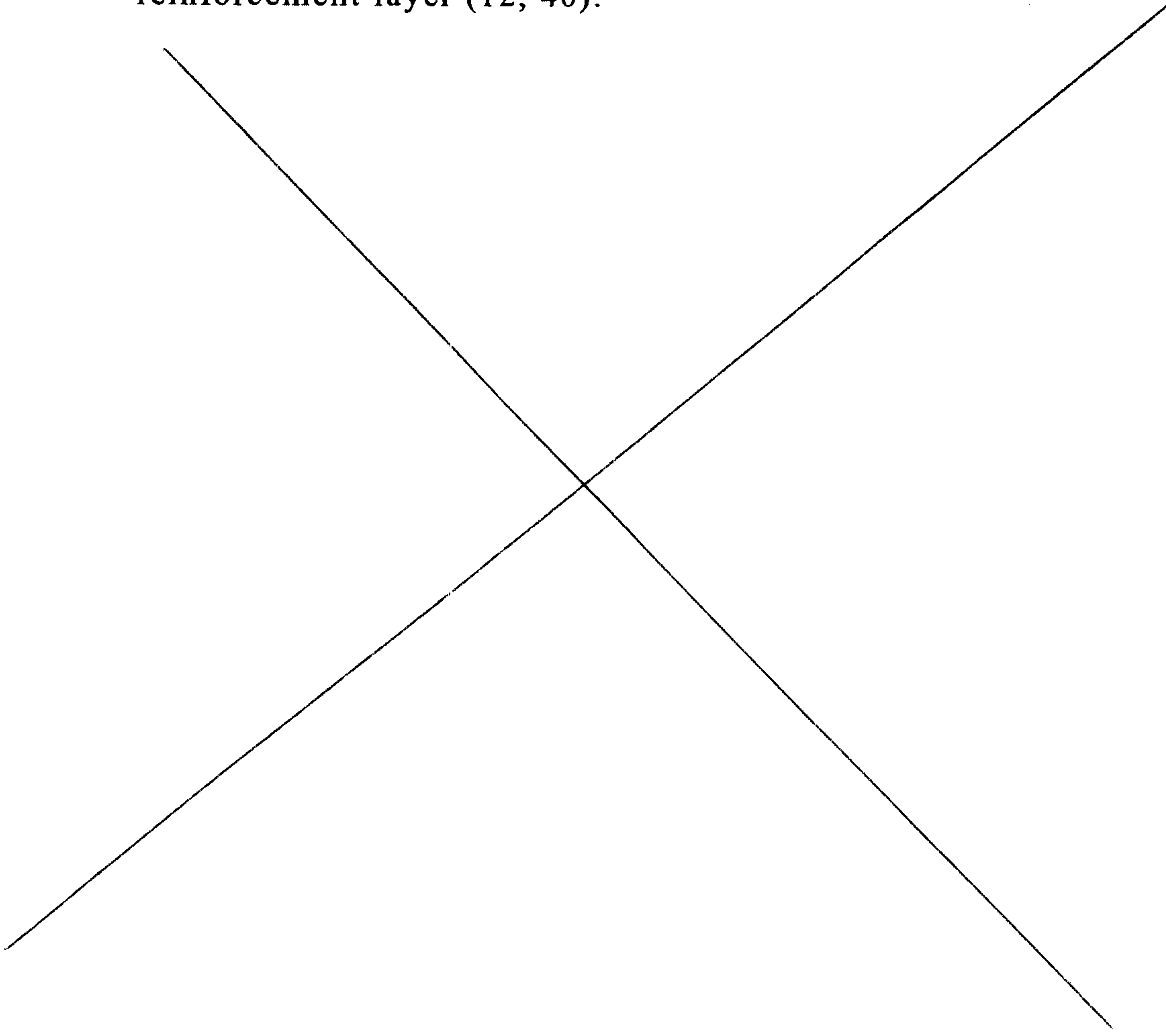
5. A base unit according to claim 4, characterized in that the reinforcement layer (12, 46) is provided with a window opening (23, 43, 48) for at least proportionally accepting a chip unit (17) and the chip unit contacts an antenna coil (18, 42) made of wire (28) for forming the transponder unit (16, 41).
6. A base unit according to claim 5, characterized in that the reinforcement layer (12) is provided with additional window openings (49, 50) for accessing the contact regions (51, 52) of the chip unit (17).
7. A base unit according to claim 5 or 6, characterized in that the chip unit (17) is at least partially surrounded by a reinforcement device (44) surrounding the chip unit and extending in the plane of the reinforcement layer (12, 46).
- 

17a

8. A base unit according to one or more of the claims 5 through 7, characterized in that the antenna coil (41) is positioned on the reinforcement layer (12) and is covered by the adhesion layer (13), forming a plane adhesion surface (14).
9. A base unit according to one or more of the claims 5 through 7, characterized in that the antenna coil (18) is at least proportionally embedded in the reinforcement layer (12, 46) and is covered by the adhesion layer (13, 47), forming a plane adhesion surface (14).
10. A base unit according to one or more of the claims 4 through 9, characterized in that the adhesion surface (14) of the adhesion layer (13, 47) is covered by a deadening layer (15).
11. A base unit according to claim 10, characterized in that the deadening layer is embodied by the clear surface of the reinforcement layer (12, 46) of an additional base unit (19).
12. A process for producing an identification label according to one or more of the claims 1 through 3, characterized in that

- a base unit (19) according to one or more of the claims 4 through 11 is provided and
- an identification layer (11) is applied onto the base unit (19).

- 5 13. A process according to claim 12, characterized in that a carrier layer (37) is applied onto the base unit (19, 45) prior to applying the identification layer (11) for forming an intermediate layer.
- 10 14. A process according to claim 12 or 13, characterized in that a permanent adhesion layer (33) is applied onto the base unit (19), the identification layer (11), or the carrier layer (37) in order to be mounted between the base unit (19) and the identification layer (11) or the carrier layer (37).
- 15 15. A process according to claim 12 or 13, characterized in that an additional adhesion layer (47) is applied onto the base unit (45), the identification layer (11), or the carrier layer (37) in order to be mounted between the base unit (45) and the identification layer (11) or the carrier layer (37).
- 20 16. A process according to one or more of the claims 12 through 15, characterized in that the coding of the identification layer (11) and the coding of the transponder unit (16, 41) occur in a common coding process.
- 25

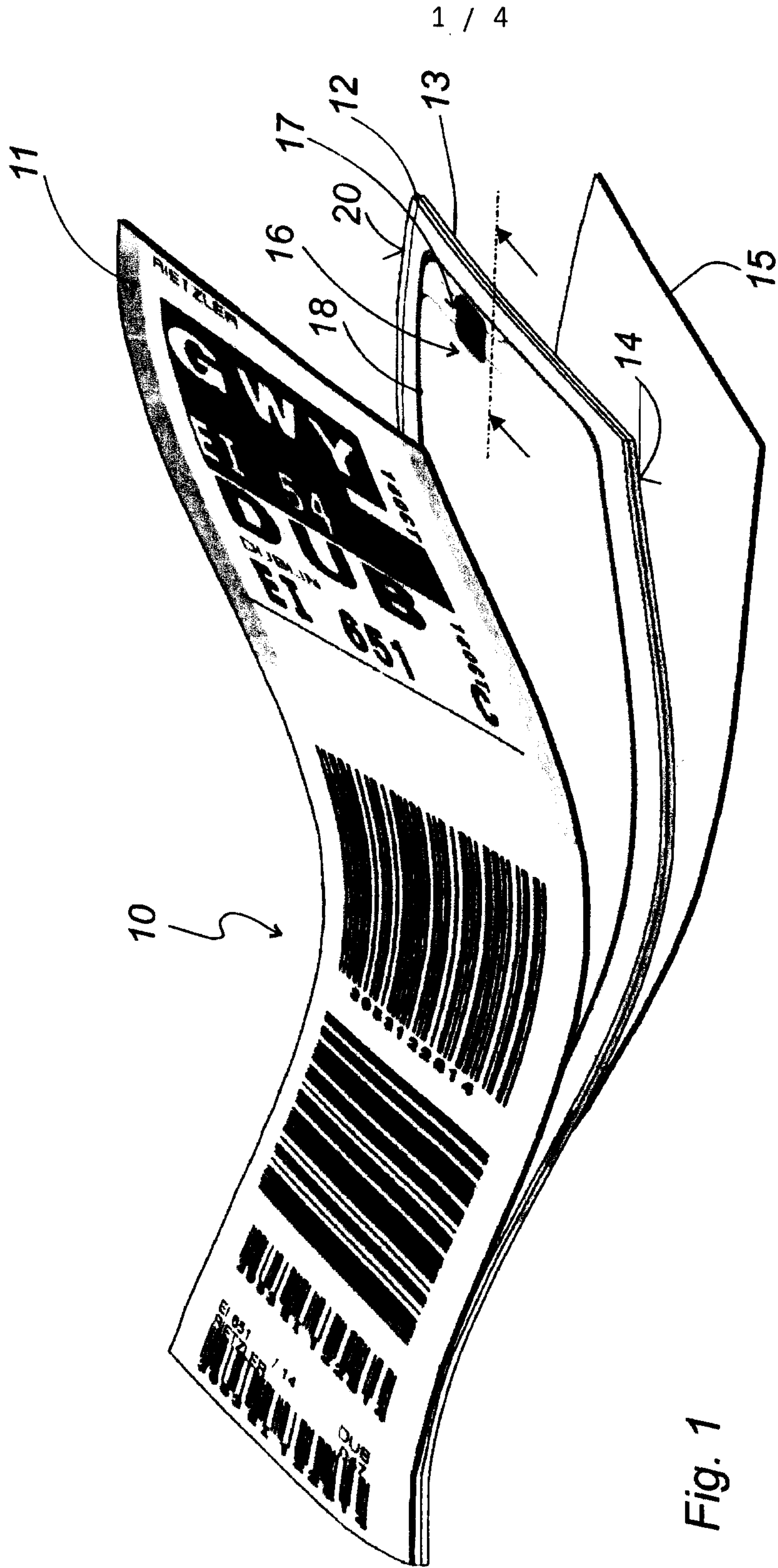

Fig. 1

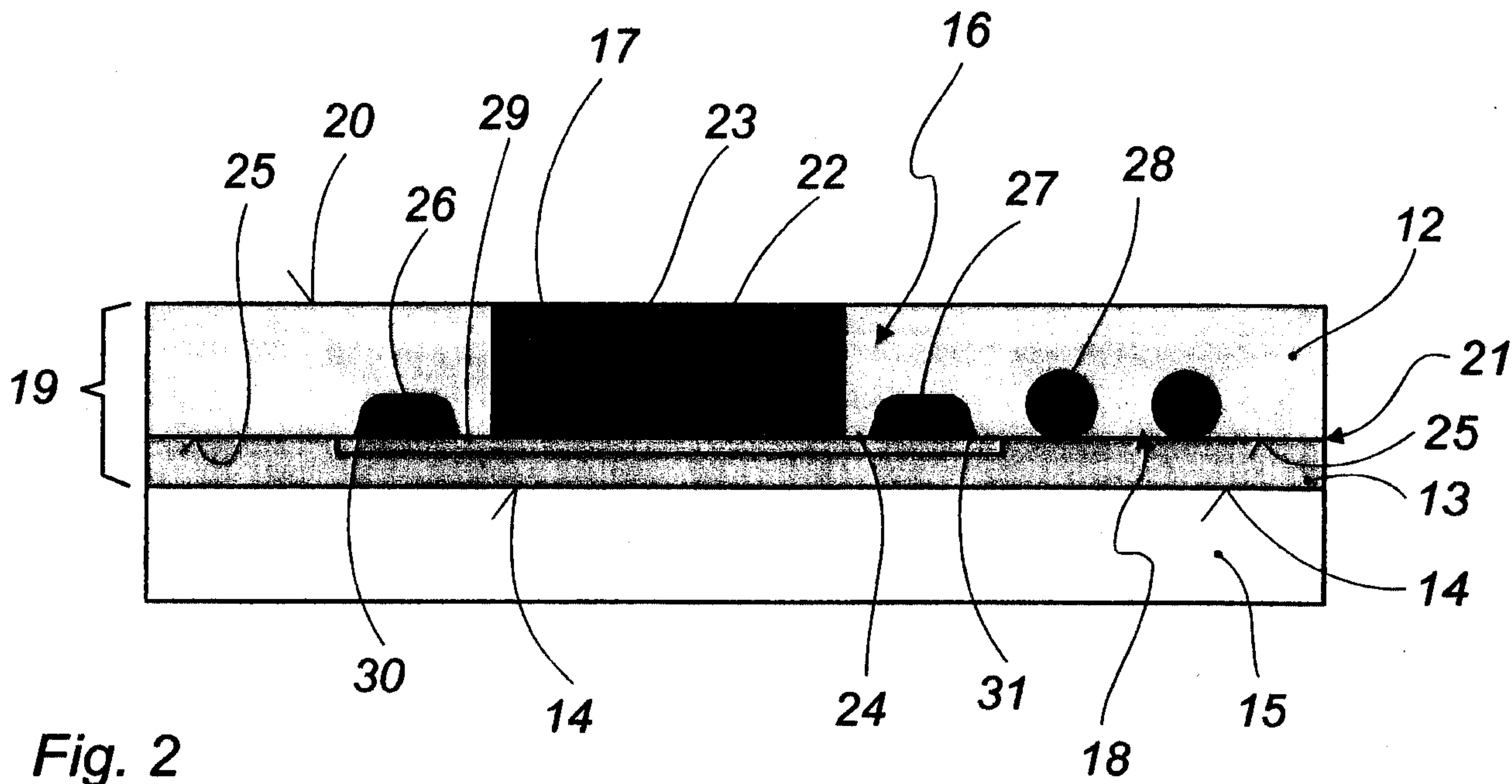

Fig. 2

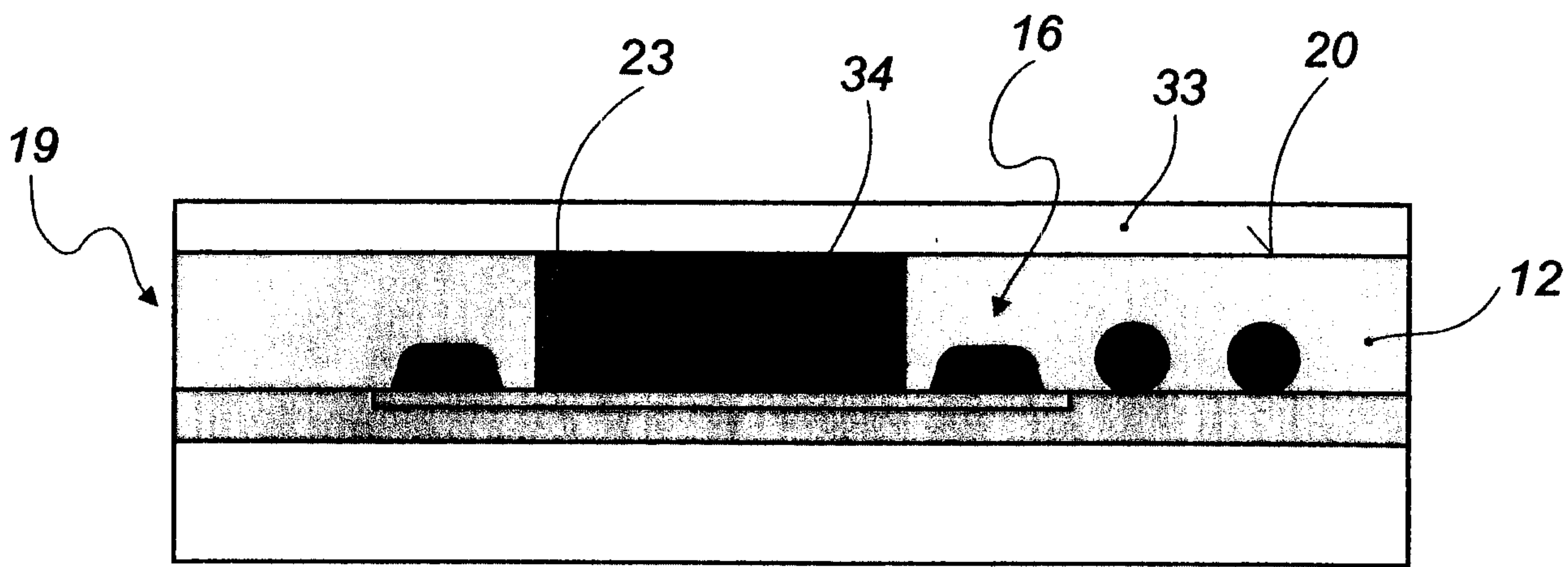

Fig. 3



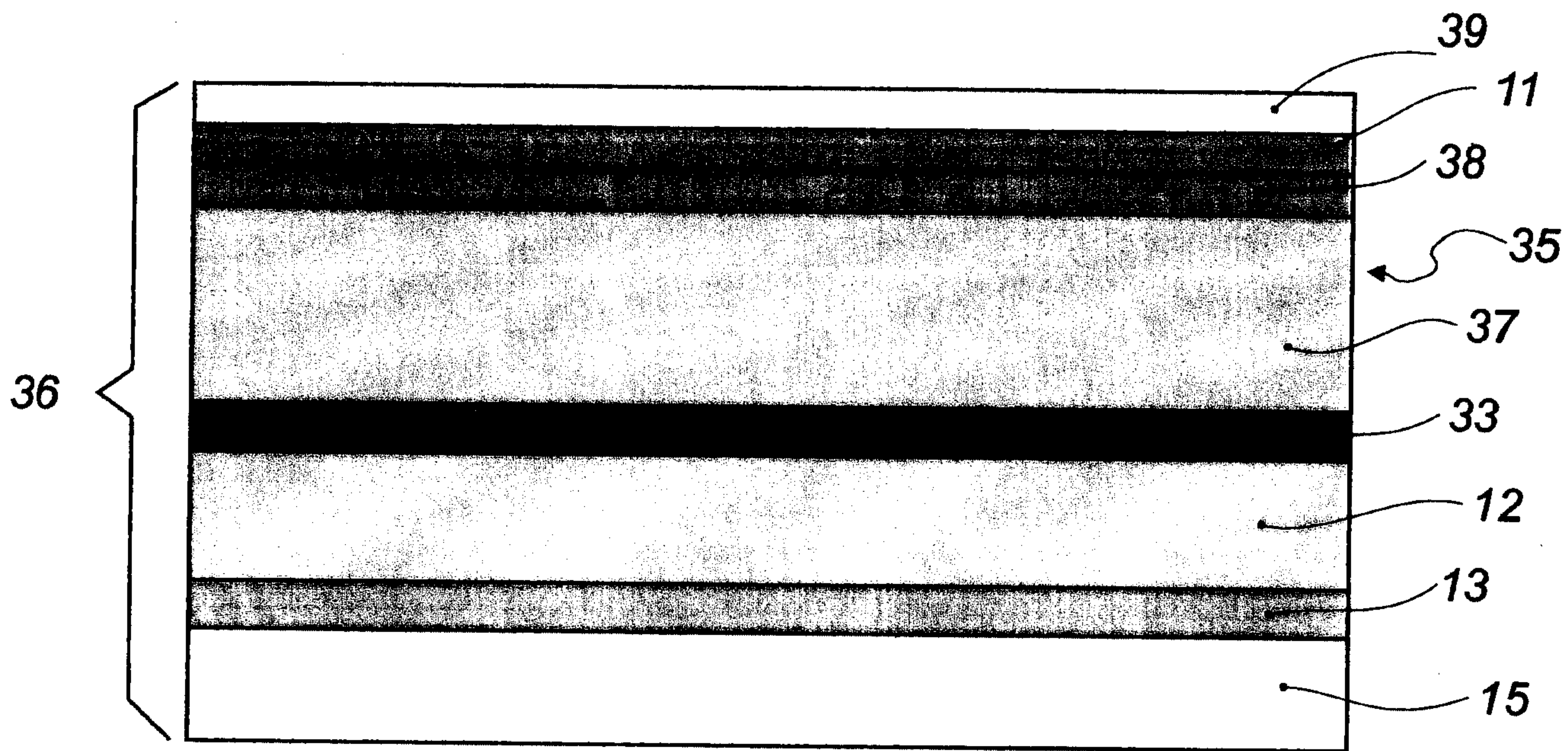

Fig. 5

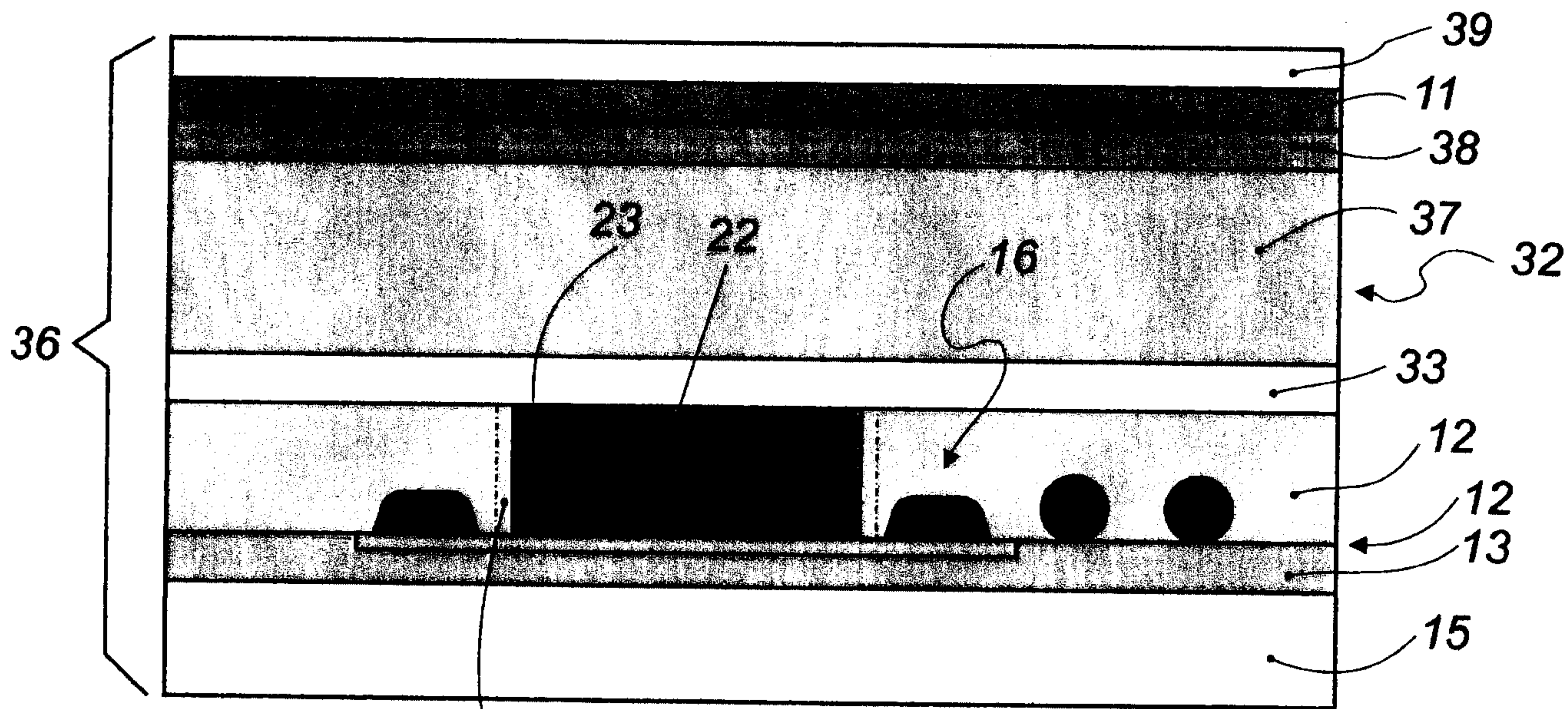
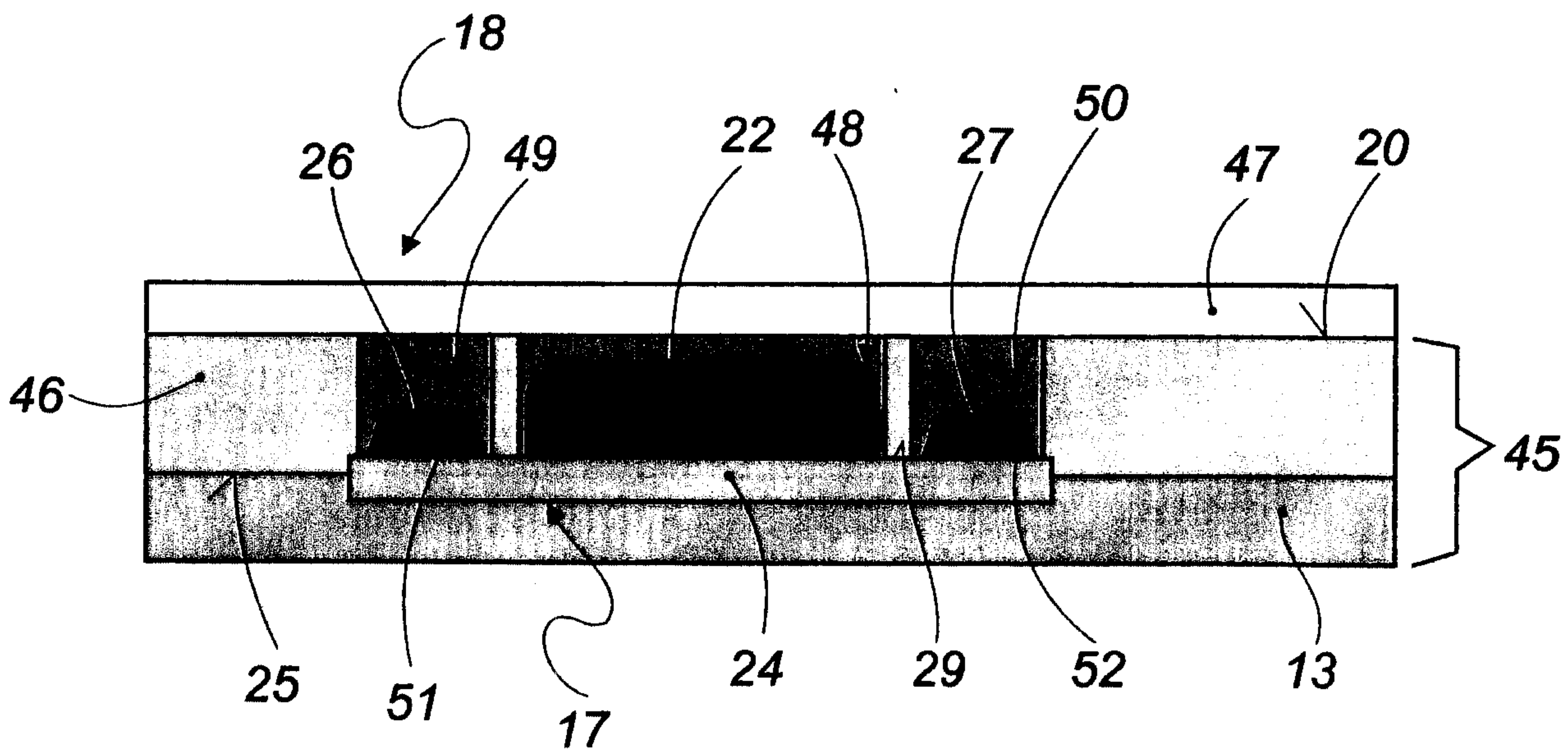
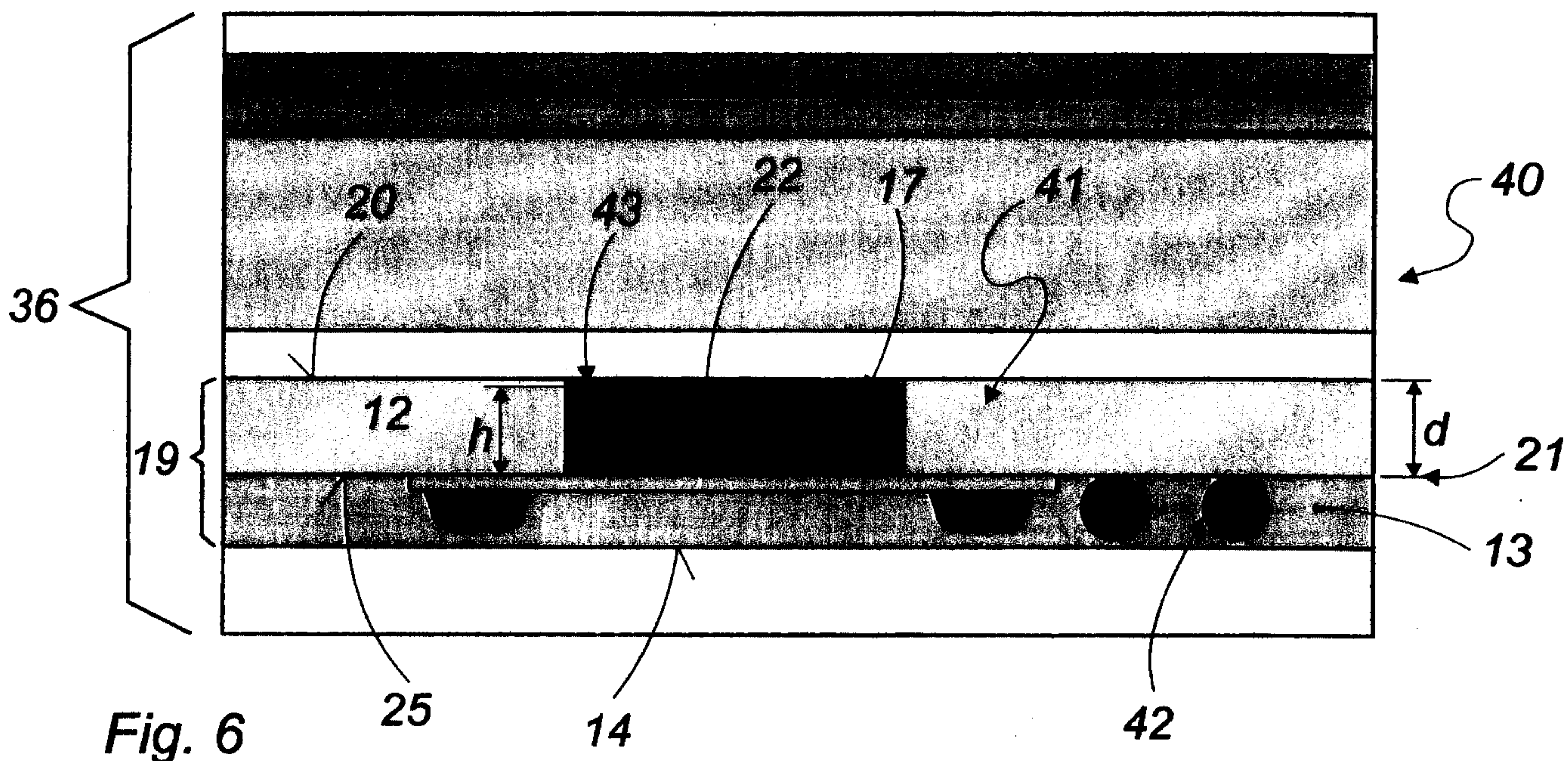

Fig. 4

44



### **Abstract**

The invention relates to an identification label (10) to be fastened on the surface or around articles. Said identification label has a multi-layer structure with an identification layer (11) for optically labeling, a reinforcement layer (12) for mechanically stabilizing the identification layer and an adhesive layer (13) for fastening the identification label on the article. The reinforcement layer serves as the substrate for arranging thereon a transponder unit (16).

