

[54] **PROPORTIONED RESISTANCE EXERCISE SERVO SYSTEM**

[76] Inventor: **Evan R. Flavell**, P.O. Box 6397,
 Astoria, Oreg. 94706

[22] Filed: **July 10, 1972**

[21] Appl. No.: **270,219**

[52] U.S. Cl. **73/379**, 272/79 R, 272/DIG. 006,
 272/DIG. 005

[51] Int. Cl. **A63h 21/24**

[58] Field of Search 272/DIG. 6, 79;
 128/2.05 R; 73/379, 137, 138

[56] **References Cited**

UNITED STATES PATENTS

3,395,698	8/1968	Morehouse	128/2.05
3,602,502	8/1971	Hampl	272/69
3,744,480	7/1973	Gause et al.	128/2.05 R

Primary Examiner—George J. Marlo
Assistant Examiner—Joseph R. Taylor
Attorney, Agent, or Firm—Owen, Wickersham &
 Erickson

[57] **ABSTRACT**

A proportional resistance exercise servo device. User interfacing means is connected to a drive shaft so that the user applies force to said drive shaft and vice versa. The device applies braking force to the drive shaft as it is rotated in a first direction by user-exerted force on the interfacing means, in a braking mode; and it applies power to drive the drive shaft in a second direction and thereby exerts force on the interfacing means, in a power mode. Direction reversal means automatically stops the braking at a first limit and thereafter applies power thereto, and automatically stops the power at a second limit and thereafter begins braking it. Both the braking and powering are programmed, but feedback alters the program in accordance with the user's performance. Acceleration and deceleration are controlled. Various performance parameters are displayed or recorded.

12 Claims, 9 Drawing Figures

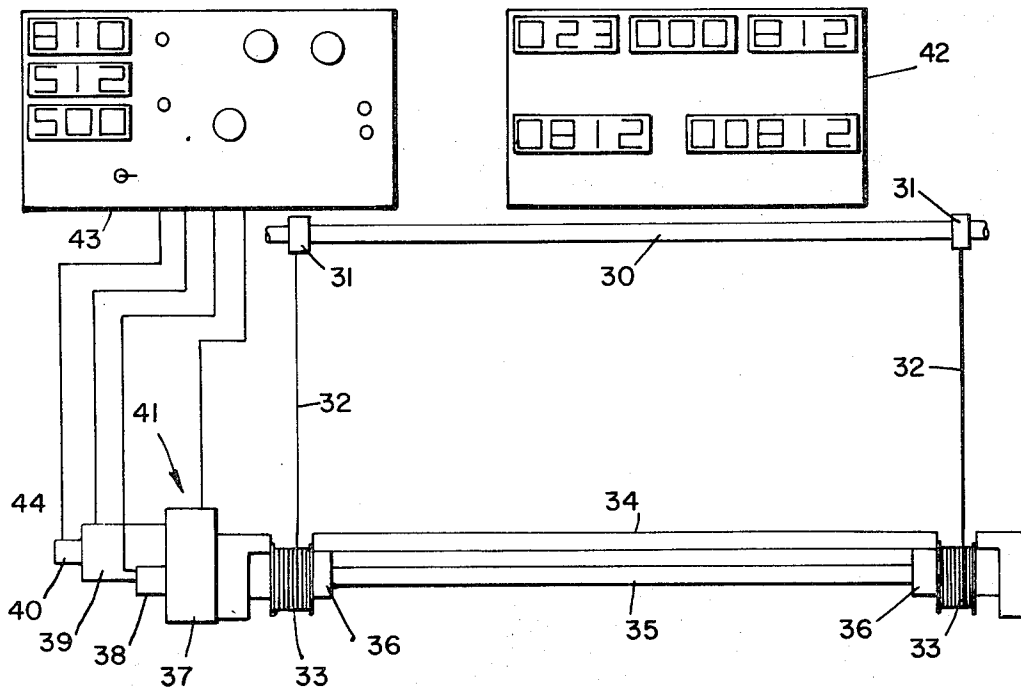
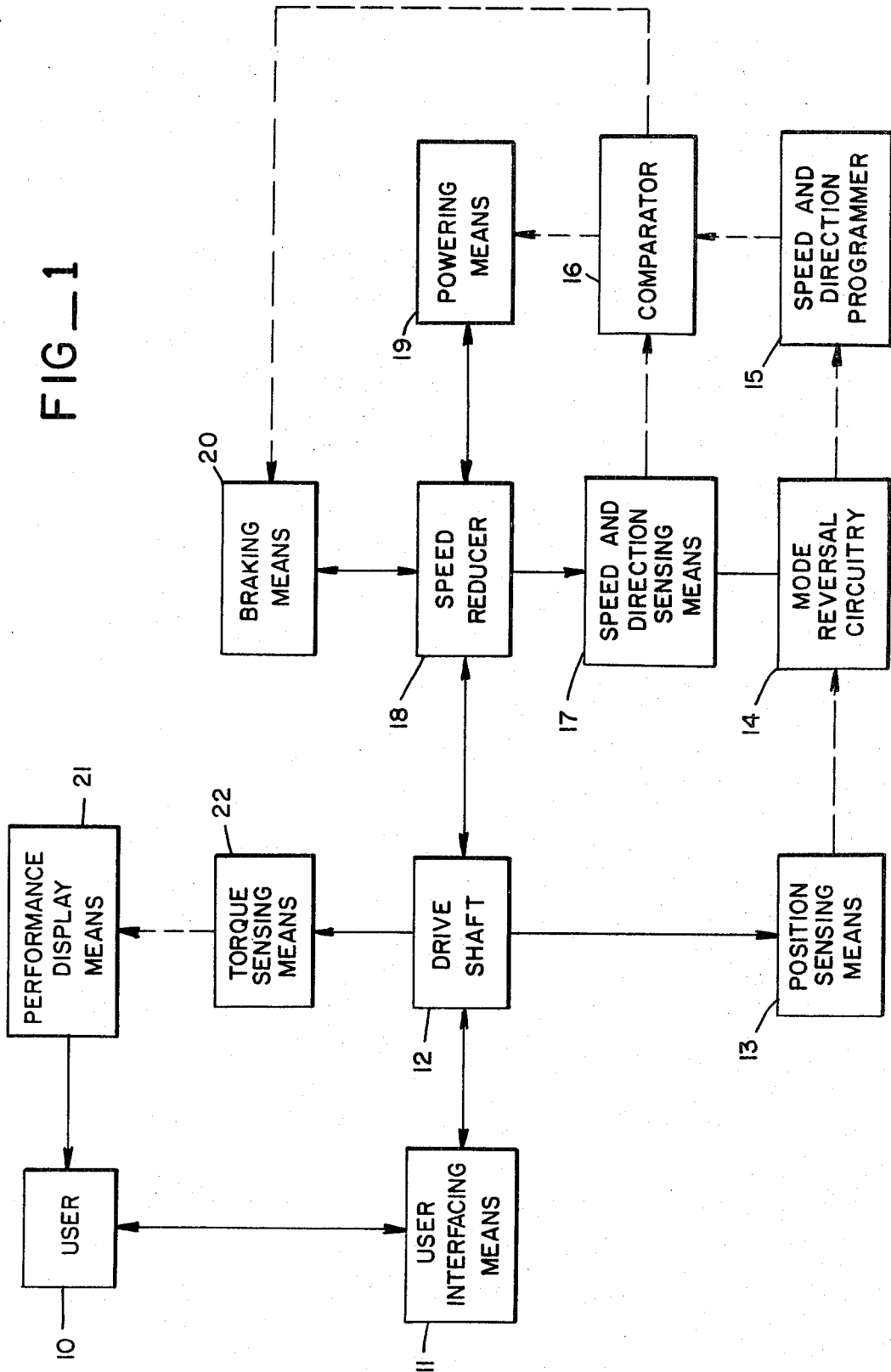
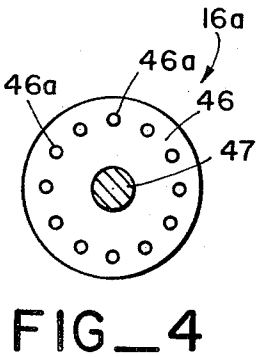
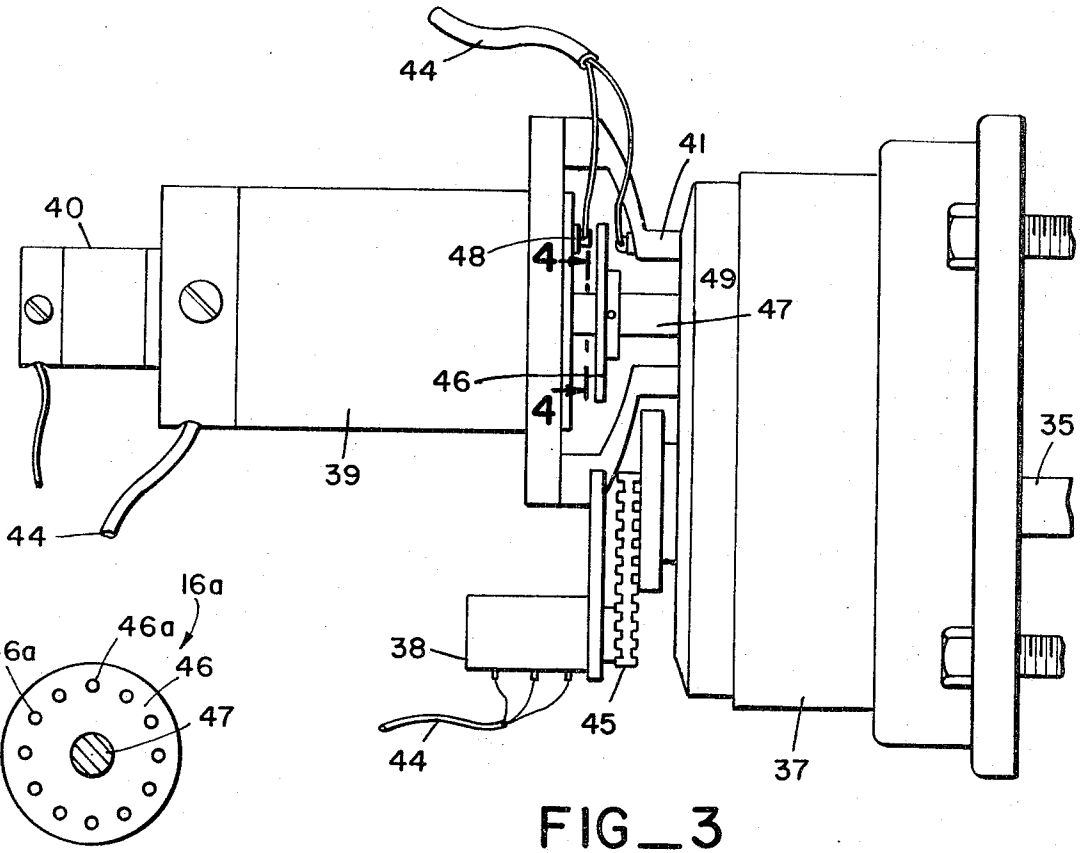
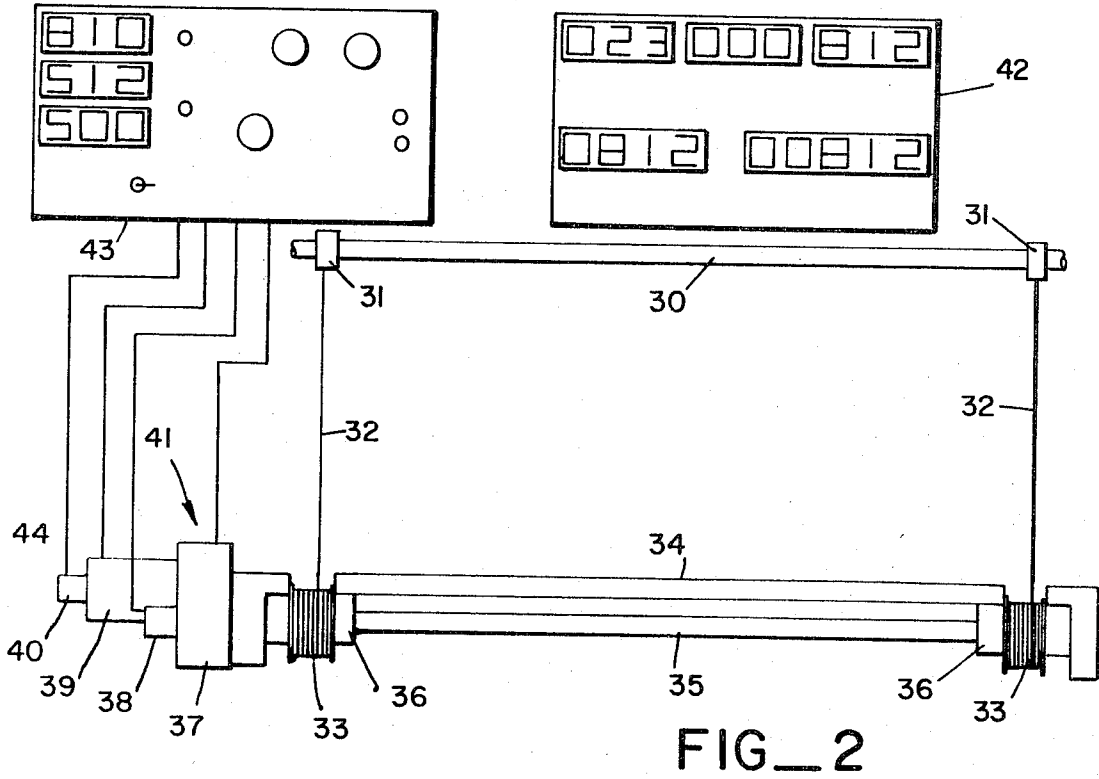

FIG. 1





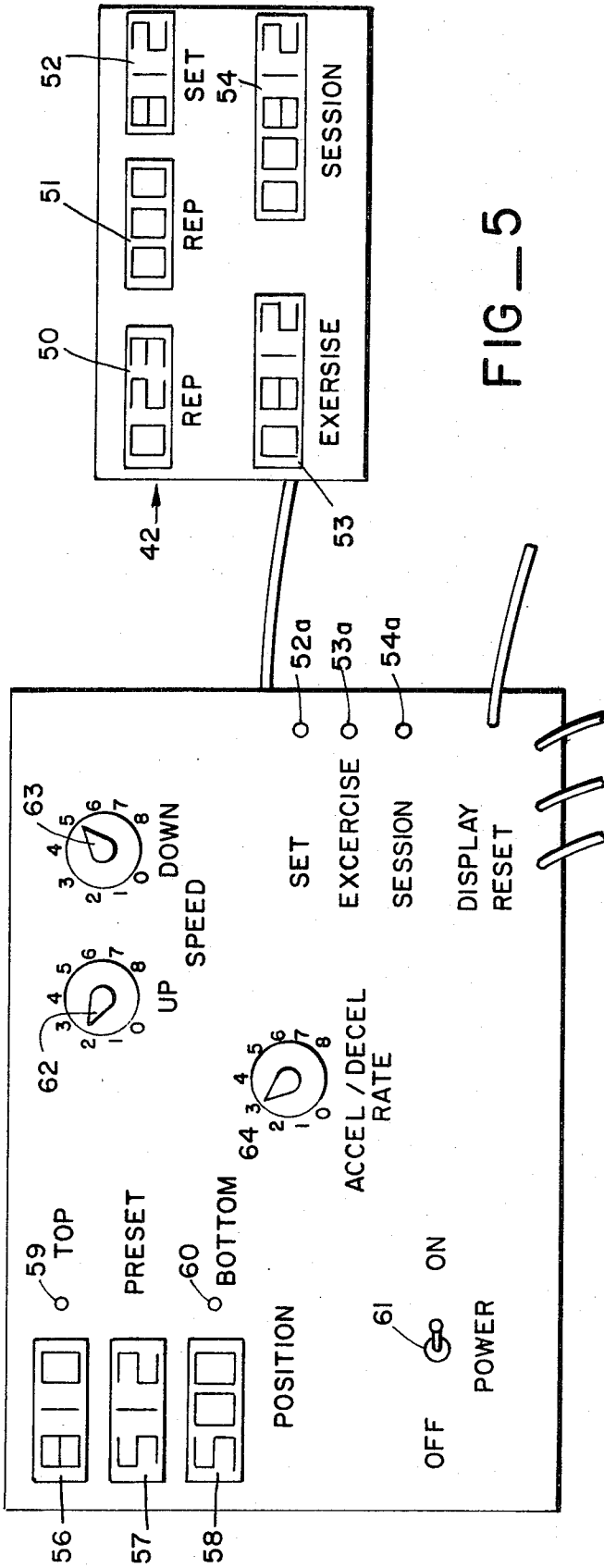

FIG-5

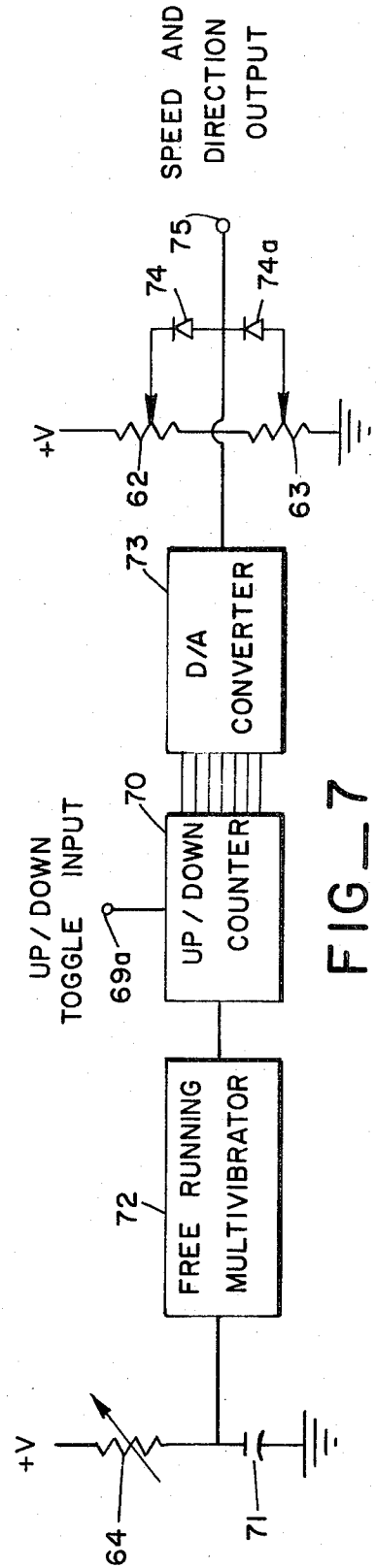
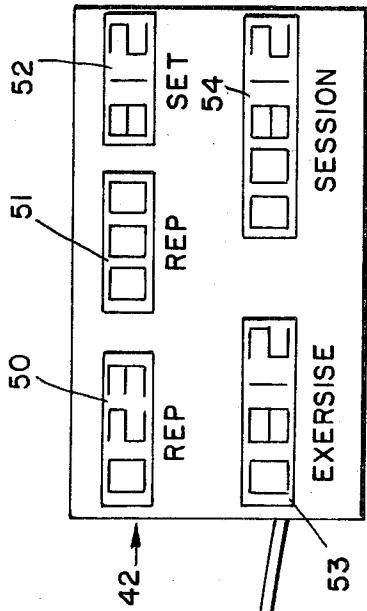
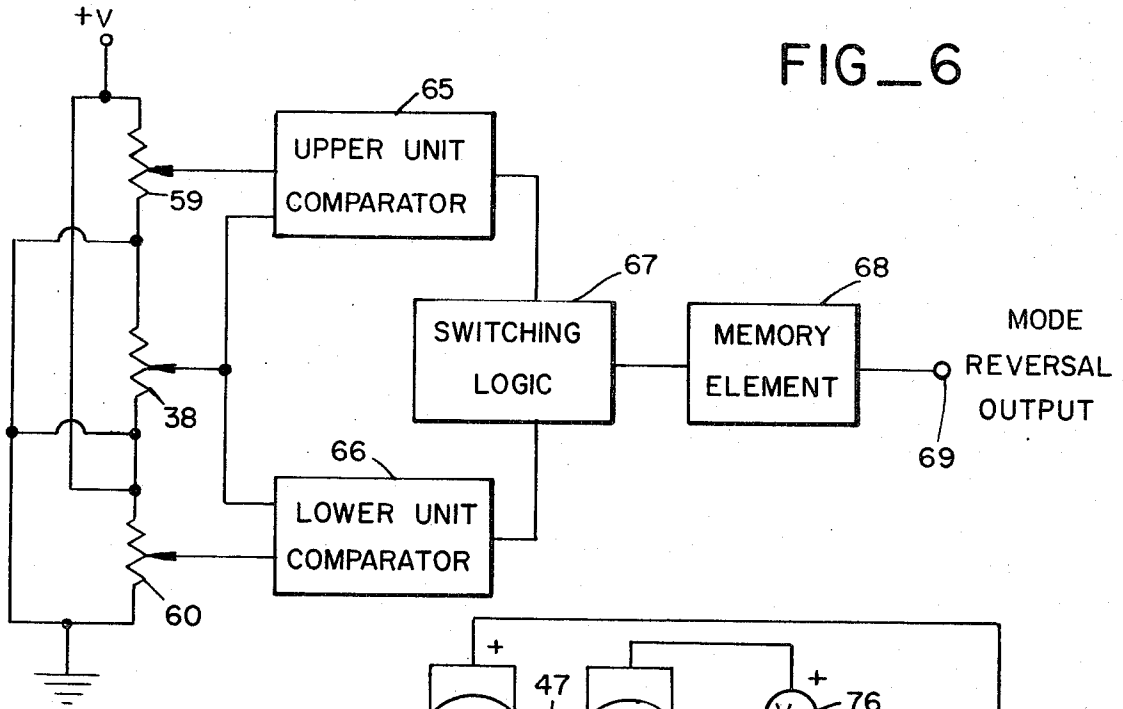
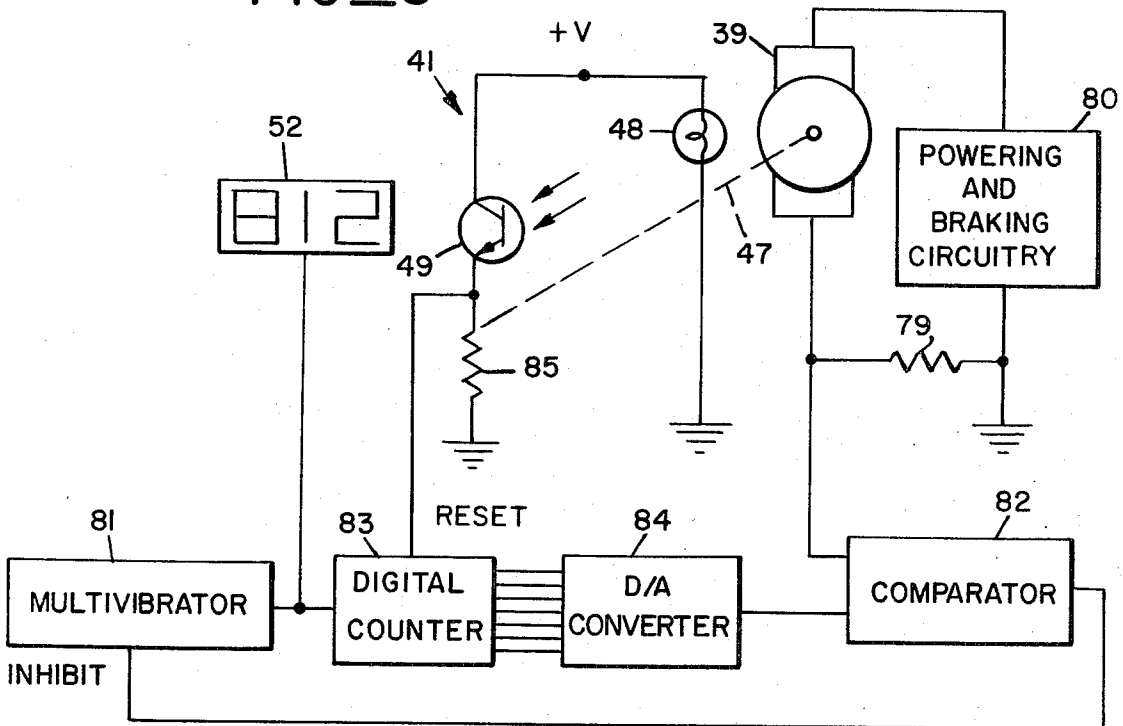
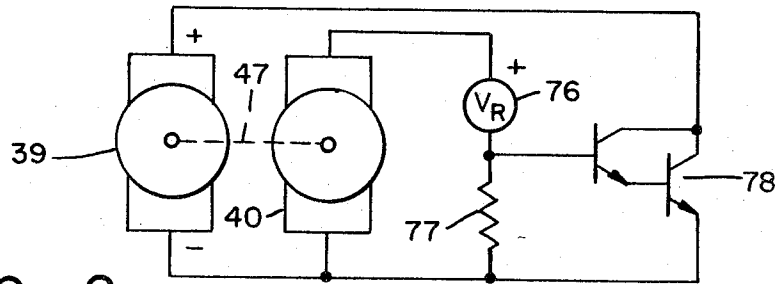

FIG-7

FIG_6



FIG_8



FIG_9

PROPORTIONED RESISTANCE EXERCISE SERVO SYSTEM

BACKGROUND OF THE INVENTION

The present invention relates generally to improvements in exercising apparatus. More particularly, it relates to a system wherein the resistive force of the apparatus is proportioned to the instantaneous capacity of the user and is presented to the user in a reciprocating fashion with controlled acceleration and deceleration and simultaneous display of performance parameters.

The principle of progressive-resistance exercise, wherein the induced demand on the human system is progressively increased as that system, through natural physiological compensation, increases its capacity to handle increased demands, has been known and relied on to improve the strength, endurance, and flexibility of the human system since the time of legendary Milo, who was said to have introduced the principle by lifting a growing bull each day. According to the legend, Milo's body compensated for the progressively increasing demand placed upon it by the increasing weight of the bull by increasing his strength accordingly. Similarly, today's weightlifter progressively increases the weight of the barbell he lifts, today's runner progressively increases his distance and speed, and the patient in rehabilitation progressively increases the range of movement of his damaged shoulder, each manipulating his body's natural compensatory processes toward the desired objective, increased strength, endurance, and flexibility, respectively.

Since Milo's time, a variety of exercise devices has been developed, each seeking to provide, in a more convenient configuration than Milo's bull, a progressively increasable exercise resistance, preferably also of sufficient versatility that a variety of general and specialized exercises might be performed on the same device. Barbells, dumbbells and weight-pulley machines are representative of such developments.

A significant disadvantage of these prior-art devices has been that, although the resistance was adjustable from exercise to exercise to compensate for variations in the capacity of the user, once a specific resistance was chosen, it remained constant for each of the immediately sequential repetitions of the exercise performed. Thus, less than maximal demand was placed upon the bodypart being exercised in all but the last performable repetitions of the exercise. Better results would be obtained by an exercise system that could progressively increase its resistance as the body became stronger and, at the same time, change its resistance to compensate for the variable, primarily decreasing capacity of the user during the course of several sequential repetitions, or several sequential sets of repetitions. Maximal demand would be placed upon the bodypart being exercised during a significantly increased proportion of the exercise time, and exercise program efficiency, if not results as well, would be significantly improved over what is realizable with fixed resistance devices.

Fixed resistance devices suffer the further shortcoming of being unable to compensate for variations in capacity existing during the course of a full range of movement of a single repetition of an exercise. It is common knowledge, for example, that during the per-

formance of the biceps curl, in which a weight is raised to the shoulder about the axis of the elbow, it is characteristic of the leverages involved that more load can be raised through certain angles of this movement than others, that is, that one is stronger at certain points in the movement than others. Thus, using a fixed resistance device such as a dumbbell for the movement, one necessarily limits the magnitude of that resistance to the maximum amount that can be moved at the weakest angle, and all other angles are sub-maximally loaded. Again, better results would be obtained by an exercise apparatus that could automatically vary the applied exercise resistance as is appropriate to compensate for the variations in capacity characteristic of human skeletal leverage systems. Such apparatus would constitute a significant improvement over existing fixed resistance approaches.

Mechanical exercise devices have been developed which provide a varying resistance during the course of specific movements according to a preset program establishing a specific proportion of a fixed resistance as appropriate for each specific point in the movement. The resistance at any single point, however, remains fixed from repetition to repetition, and, therefore, although these devices are an improvement over simple fixed resistance, they are not as good as a device incorporating variable resistance within each repetition, among repetitions and sets of repetitions, as well as among exercises and exercise sessions.

The task of providing variable exercise resistance that would, even approximately, compensate for so complexly varying a parameter as the instantaneous capacity of the human system performing exercise movements is clearly unobtainable except by servo system technology incorporating a sensing of that instantaneous capacity as a control means for the variable resistance.

The desired sort of variable resistance, herein termed "proportioned" resistance, as this is most appropriately descriptive of the technology involved, has been incorporated into a variety of exercise apparatus of recent design and manufacture. In these devices, proportioned resistance is conventionally achieved as a by-product of regulated speed, and the regulated speed is obtained through classical servo system means, wherein a secondary feedback mechanism is employed to regulate the primary powering or braking function. In one device, for example, a centrifugally governed braking device regulates the speed of rotation of an unwinding drum, around which is wrapped a cable to which the user applies a pulling force to obtain exercise. The net effect is that, once the device reaches regulated speed, the harder the user pulls on the cable, the more resistance is afforded the user by the device, and the exercise resistance is, therefore, variable and is proportioned to the instantaneous capacity of the user.

Yet, although existing proportioned resistance exercise devices do provide the presumed optimum variable and progressive exercise resistance via servo means, they are believed to be universally lacking in one or more additional elements believed equally essential components of an optimally integrated proportioned resistance exercise system.

For one thing, proportioned resistance for exercise purposes is most effectively provided in a reciprocating fashion such that eccentric muscular contractions (as when a weight is lowered from the shoulder in a biceps

curl) and concentric contractions (as when the weight is raised to the shoulder in the same exercise) are both made against a proportioned resistance in a continuous alternating sequence. The necessity of this operating characteristic derives from the apparent physiological fact that significant muscle recovery occurs in a very short period of relaxation (a few seconds), and, assuming that the desired objective of an efficient exercise system is to exhaust a muscle's capacity in the shortest practical elapsed time, any allowed period of relaxation in an exercise movement serves to diminish the cumulative exercise effect of the present repetition upon subsequent ones. Also, while it would seem possible and practical to devise a system that would totally exhaust a muscle's capacity in a single, uni-directional repetition, thereby eliminating the necessity of a reciprocating action, this uni-directional approach is believed not to produce optimum results.

Thus, to obtain a reciprocating operation characteristic, in addition to a speed-regulating feedback mechanism to produce proportioned resistance, the desired exercise system must incorporate a second servo loop, wherein the immediate position of the device respective to presettable limits designating a specific desired range of movement and the immediate direction of movement of the device combine to initiate an automatic reversal in that direction of movement at the specific desired positions. Such an automatic reversal mechanism not only provides the required reciprocating action, but also does so without distracting the concentration of the user upon his primary exercise purpose, the importance of which will subsequently be outlined, as would occur were the reversals controlled by the user himself, and without the participation of an attendant, as might otherwise be necessary in a physiotherapeutic situation.

As may already be apparent from the discussions above, the described regulated-speed approach to providing a proportioned exercise resistance suffers the imperfection of responding not to the user's absolute instantaneous capacity, but rather, to his apparent capacity, because the resistance is controlled by the amount of force the user exerts upon the mechanism. It will be recalled that the net characteristic operation of this indirect approach is that the harder the user pulls on the apparatus, the harder the apparatus pulls against him. Conversely, should the user exercise with less than maximal effort, less than maximal opposing resistance is afforded him by the device, and less than optimum results are achieved. Thus, it is important that the user concentrate as totally as is practical upon exerting maximal effort throughout all exercise movements.

In order for the user to control adequately the intensity of his effort, it is essential to the function of an optimized proportioned resistance exercise servo system that a third servo loop be incorporated, wherein the user himself as an integral component is presented with a display of certain performance parameters such as force, work, or power, in comparison to which he manipulates the level of intensity of his immediate efforts, and thereby the response of the total system, and the ultimate results of his exercise endeavors. It is implicit here that such manipulation might, in fact, be at some prescribed sub-maximal level to achieve certain objectives such as increased endurance, or at maximal level

to achieve certain other objectives such as increased strength.

In the performance of conventional fixed resistance exercise movements, the subject maintains control of the movement acceleration and deceleration rates at the points of reversal of direction of movement and change between concentric and eccentric muscular contractions by varying the intensity of the contractions at these points. In an automatically reciprocating system such as that described herein, however, the user cannot effectively control these rates, which must be limited to avoid possible injury resulting from the mechanical shock loads so imposed upon him by the apparatus, without significantly diminishing the effectiveness of the exercise movement. For example, in the performance of several sequential and continuous biceps curl movements, at the points of direction of movement reversal from eccentric to concentric contractions, that is, at the "bottom" of the movement, such an apparatus as that so far described would afford the user essentially no resistance other than the inertia and friction inherent therein, as the system would be in a transitional state at this point wherein neither braking nor powering is being applied, deceleration of the present direction and subsequent acceleration in the opposite direction would be virtually instantaneous, and potentially injurious mechanical shock loads would be imposed upon the user. The same, but reciprocal, phenomenon would occur at the "top" reversal point.

To limit these mechanical shocks, the user would be required to reduce the intensity of the force he applies to the device to some sub-maximal level. Since this is contrary to the design objectives of an optimized proportioned resistance exercise servo system, a fourth servo loop must be incorporated, wherein the rates of deceleration and acceleration of the system at the direction of movement reversal points is sensed and compared to desired rates, and the rates themselves are thereby controlled through the appropriate application of compensatory powering or braking within the system during the transitional periods.

Therefore, among the objects of the present invention are the provisions of an exercise servo system wherein:

- a. a variable exercise resistance is provided that is proportioned to the apparent instantaneous capacity of the user via feedback regulated speed control means;
- b. this proportioned exercise resistance is provided during both eccentric and concentric muscular contractions with controlled relaxation periods in a continuous automatic reciprocating fashion over an adjustable range of movement;
- c. performance feedback is provided to the user indicating the intensity of his efforts and allowing his accurate manipulation thereof; and

- d. rates of acceleration and deceleration at points of reversal or direction of movement are controlled independent of the force loading of the system.

These objects are accomplished through servo system techniques employing automatic sensing and feedback control of system motion parameters, namely, direction, position, speed, and force.

SUMMARY OF THE INVENTION

To obtain exercise from a system of the present invention, the user attaches himself and applies force to

an interfacing means. For example, the interfacing means may be a bar, to the ends of which are affixed one end of each of two cables, the other ends of which are wrapped around two drums spaced the length of the exercise bar apart and mounted upon a single drive-shaft. It should be understood here that alternative interfacing means of force transmission such as levers, etc., are equally suited to the purpose of translating exercise movements into system drive shaft rotation; the bar-cable-drum approach is cited for its similarity to conventional barbell fixed-resistance exercise methodology.

The system drive shaft to which the user applies force via this interfacing means, is itself attached to a powering and a braking means, alternately operated in powering and braking modes, with feedback speed regulation, over a preset range of number of driveshaft revolutions, and consequent length of cable travel and range of exercise movement.

Thus, for example, in performance of the standard barbell curl, as the user raises the bar to his shoulders, the cable unwinds from around the drum and turns the driveshaft, to which, during this concentric contraction, a braking device provides a proportioned resistance via feedback speed regulation means. At the top of the movement, that is, when the user has raised the bar to his shoulders, the system applies increased braking to halt the upward movement of the bar at a controlled deceleration rate, and then switches to a powered mode with controlled acceleration and feedback regulated speed, rewinding the cable on the drum against the resistance of the user's eccentric contractions, until the bottom of the movement is reached. At this point, again with controlled deceleration and acceleration, the system reverses again into the braking mode, and the cycle is repeated for the desired number of repetitions to obtain the specific exercise objective.

Throughout the above movements, or preferably at the end of each repetition or half-repetition, selected exercise parameters such as force, work, power, speed, and/or time may be displayed to the user such that he may accordingly control the rate and intensity of his exercise efforts.

Thus the system provides a proportioned exercise resistance through feedback regulated speed control over a preset (adjustable) range of movement in an automatic reciprocating fashion with controlled acceleration and deceleration at points of direction of movement reversal with performance feedback to the user.

BRIEF DESCRIPTION OF THE DRAWINGS

In the drawings:

FIG. 1 is a functional block diagram of a proportional resistance exercise servo system embodying the principles of the invention. Arrows in solid lines indicate the direction of force flow and arrows in broken lines indicate the direction of signal flow.

FIG. 2 is a view in elevation of a preferred embodiment of a proportioned resistance exercise servo system incorporating the system of FIG. 1.

FIG. 3 is an enlarged view in elevation of a portion of FIG. 2 showing in more detail the powering-braking-sensing module.

FIG. 4 is a view in section along the line 4-4 showing the disc of the optical tachometer.

FIG. 5 is an enlarged elevational view in detail of the control box and performance display of FIG. 2.

FIG. 6 is a circuit diagram, part elemental and partly block of the position sensing and mode reversal portions of the system of FIG. 2.

FIG. 7 is a functional schematic, largely block-type, diagram of a speed and direction programmer used in the device of FIG. 2.

FIG. 8 is a simplified schematic diagram of the proportional braking system of the FIG. 2 device.

FIG. 9 is a functional schematic diagram of an accumulative work performance display, forming a part of the FIG. 2 device.

DESCRIPTION OF A PREFERRED EMBODIMENT

FIG. 1 shows a functional diagram of a proportioned resistance exercise servo system embodying the principles of the invention. The integrated feedback loops include the user himself and provide a controlled exercise resistance in proportion to the amount of force exerted by the user. This proportioned resistance is provided over a selected range of movement in a reciprocating fashion, that is, both through concentric and eccentric contractions of the body part being exercised, with controlled acceleration and deceleration at points of direction of movement reversal, and simultaneous display of performance parameters.

A user 10 is coupled via a user interfacing means 11 (such as a lever arm or a bar attached to a cable and drum) to a driveshaft 12. Also attached to the driveshaft 12 is a position sensing means 13, for example, limit switches, an optical encoder, or a potentiometer. Electrical signals from the position sensing means 13 are read by mode reversal circuitry 14 as to appropriate direction of rotation of the driveshaft 12. For example, assuming that the driveshaft 12 has rotated clockwise to the limit preset in the mode reversal circuitry 14, this fact is indicated electrically by the position sensing means 13 and the mode reversal circuitry 14 then sends an electrical signal to a speed and direction programmer 15 to initiate counterclockwise rotation of the driveshaft 12, until the preset limit in that direction had been reached, at which point, the direction of driveshaft 12 rotation is again reversed, providing the settable reciprocating motion characteristic of the system. Thus the speed and direction programmer 15 serves as a command for direction of rotation of the driveshaft 12. The speed and direction programmer 15 combines this mode of operation command with a variable speed program contained within its electronic memory (or externally introduced) to control acceleration, deceleration and speed variables.

The combined speed and direction signals thus produced by the speed and direction programmer 15 are sent on as reference signals to a comparator 16. The comparator 16 compares these reference signals from the speed and direction programmer 15 with electrical signals from a speed and direction sensing means 17, which may, if desired be coupled to the system driveshaft 12 via a speed reducer 18, and generates error signals in proportion to any difference between actual system speed and direction of rotation and the electrical "instructions" of the speed and direction programmer 15.

The error signals from the comparator 16 serve as commands for the powering means 19, such as an elec-

tric servomotor, and braking means 20, such as an electromagnetic brake, to initiate the appropriate compensatory action, that is, via intermediate transmission components, namely, the speed reducer 18, as required, such as a gearbox, belt and pulley, or chain and sprocket drive, to apply to the driveshaft 12 powering and/or braking forces of the appropriate magnitude and direction to correct for speed and direction of rotation errors and thereby maintain the total system in equilibrium. Thus, proportioned resistance is provided to the user 10, as the system speed is feedback regulated and therefore instantaneously responsive to varying exercise force applied to the driveshaft 12 during both concentric and eccentric muscular contractions. Although the speed and direction sensing means 17 is shown in this functional diagram coupled to the speed reducer 18, it might just as feasibly be coupled to other system components such as the powering means 19, braking means 20, or the driveshaft 12.

Completing the primary system servo loop so far described is a performance display means 21, wherein the energy either supplied or dissipated in the above compensatory process is translated into an appropriate display of force, work, and/or power. This serves as feedback to the user of the results of his exercise efforts, and might be presented on cathode ray, matrix, analog, digital, or printout display, as appropriate for specific performance objectives. These performance measurement parameters might also be recorded and stored for subsequent utilization in progress assessment.

The performance display means 21 is shown in this diagram as coupled to the driveshaft 12 via a torque sensing means 22, but it might just as suitably be coupled also to the speed reducer 18 or to the powering means 19 or to the braking means 20. Clearly, measurement and display of complex performance parameters such as power of the user would require integration of inputs from several system components, including the torque sensing means 22, the position sensing means 13, and the speed and direction sensing means 17, as well as independent external sources such as a time clock.

It should be noted that although the general frame of reference of the above description of the functional diagram presented in FIG. 1 has been electrical in nature, forces and signals of mechanical and/or hydraulic (fluidic) form might as effectively be utilized throughout, or in combination, as required to optimally perform the functions described herein. Note also that the arrows in solid lines show the directions of force flow, while the arrows in broken lines show the directions of signal flow.

FIG. 2 shows a preferred embodiment of a proportioned resistance exercise servo system incorporating the principles and functions outlined in the more generalized functional diagram of FIG. 1. Here, an exercise bar 30, a pair of bearings 31, a pair of cables 32, and a pair of drums 33 comprise the interfacing means 11 between the user 10 (who stands on a platform 34 and applies force to the exercise bar 30) and the system's driveshaft 35, a specific embodiment of the driveshaft 12. The driveshaft 35 is supported by and is free to rotate within a pair of pillow blocks 36.

The driveshaft 35 is coupled to a gearbox 37, which performs the speed reduction and torque increasing function of the speed reducer 18. Also coupled to the gearbox 37 are a multi-turn potentiometer 38, which is

used as the position sensing means 13, a permanent magnet servo motor 39, which is used as both the powering means 19 and the braking means 20, a tachometer/generator 40, and, contained within the motor mounting flange, an optical tachometer 41, which corresponds to the member 22 in FIG. 1 and is more clearly shown in a subsequent figure, used to supply speed sensing as input to a performance display 42, corresponding to the member 21 in FIG. 1.

Also shown is a control box 43 which contains control, regulation, and power supply circuitry to fulfill mode reversal, speed and direction programming, comparator, and performance parameter integration functional requirements (of elements 14, 15, 16, and 17 in FIG. 1), and the circuit to the box 43 is detailed in subsequent figures and descriptions. Powering, braking, sensing, and display components are connected to the control box with electrical cables 44.

Proper and effective utilization of the apparatus will be apparent to those skilled in the art who study this figure and prior and subsequent figures and descriptions contained herein. The specific apparatus described is but one of numerous practical embodiments of the four servo functions considered essential to an optimized exercise servo system, namely, proportioned resistance, automatic reciprocating action, controlled acceleration and deceleration, and performance feedback. Certain of the specific approaches contained in this apparatus are believed to be unique in the state of the art, and these approaches, particularly, are further detailed in this description of the preferred embodiment of the apparatus.

FIG. 3 shows in detail the system gearbox 37 and associated components, comprising a powering-braking-sensing module. A positive traction belt 45 is shown coupling the driveshaft 35 to the multi-turn potentiometer 38. Also, the details of the optical tachometer 41 are shown. A disc 46 is mounted upon a servomotor shaft 47. Near the circumference of this disc 46 and concentric about its axis of rotation are a number of suitably spaced holes 46a, as shown in FIG. 4. As the disc 46 rotates, these holes 46a consecutively appear between a light source 48 and a photodetector 49. As the holes in the disc 46 pass between these components, a series of pulses is generated by the photodetector 49 proportionate in number to the amount of rotation of the servomotor shaft 47, and, therefore, proportionate to the distance of travel of the exercise bar 30. The frequency of these pulses is a measure of system distance of movement as well as speed, and is used as one parameter in the performance readout system outlined in subsequent figures. The components shown in FIG. 3 comprise the complete assemblage of powering, braking, and sensing functions of this embodiment of my new proportioned resistance exercise servo system, fulfilling all of these functional requirements herein considered essential.

FIG. 5 shows in more detail the system control box 43 and the performance display 42. Both would usually be located remote from the remainder of the system but connected to it via electrical cables 44. For example, the control box 43 may be placed to one side of the user, such that he can conveniently make adjustments between exercises, while the performance display 42 may be located in front of him such that he can observe performance parameter readout while exercising.

As shown here, the performance display 42 is configured so as to present an accumulative measurement of amount of work done in "scoreboard" fashion. Digital indicators 50 and 51 alternately display and hold a numerical count proportional to the amount of work done in the just-completed repetition. As shown in FIG. 5, twenty-three units of work have been done in the previous repetition, whereas none have been done in the current one. An indicator 52 shows that 812 units of work have been done in this "set" (several sequential repetitions) of the exercise. An indicator 53 displays the same parameter for several sequential sets, and an indicator 54 shows the same for several sequential exercises.

Push buttons 52a, 53a, and 54a are provided on the control box 43 for the user to reset the three digital indicators 52, 53, and 54 at the end of each set, exercise, and session, respectively. The "rep" digital indicators 50 and 51 reset automatically at the beginning of alternate repetitions of an exercise.

On the control box 43, digital indicators 56, 57, and 58 display uppermost point of reversal, present position, and lowermost point of reversal, respectively. Thus, after once establishing an optimum range of movement for a particular exercise, the user may repeatedly "dial" the appropriate settings into the system at subsequent exercise sessions. This is accomplished with range setting potentiometers 59 and 60. A master switch 61 connects and disconnects the system to the power line. The speed of upward movement of the exercise bar 30, its downward movement, and its rate of acceleration and deceleration at points of direction reversal are controlled respectively with speed and acceleration settings potentiometers 62, 63, and 64, respectively. Additional controls and indicators may be included as required, such as force limitation, elapsed time, speed and range of movement programming, etc., or, controls may be eliminated through the incorporation of automatic programming means, such as magnetic cards, computer memory, etc., if desired.

FIG. 6 shows a functional schematic diagram of position sensing and mode reversal circuitry. The multi-turn potentiometer 38 and is attached to the system drive shaft 35, and rotates with it; its setting is therefore dependent upon the position of the exercise bar 30, and it serves as a position sensing means in the system.

The output of this potentiometer 38 is compared to the outputs of two reference potentiometers, the range setting potentiometers 59 and 60, by an upper limit comparator 65 and a lower limit comparator 66, respectively, both standard voltage comparator units. Thus, as the exercise bar 30 approaches its preset upper limit, the upper limit comparator 65 sends an electrical signal to a switching logic circuit 67, which initiates through a memory element 68 a command at a mode reversal output 69 for reversal of direction of driveshaft rotation. The same thing occurs via the lower limit comparator 66 as the exercise bar 30 approaches its preset lower limit, and the required automatic reciprocating movement of the exercise bar 30 is thereby accomplished.

The switching logic 67 is configured by well-known means such that the position sensing potentiometer 38 setting must be higher than both the upper and lower limits before reversal into a downward movement of the bar 30 is initiated, as it is possible to set the lower limit above the upper limit, which case must yield no

mode reversal. The memory element 68 holds the system in one of the two operating modes (upward or downward movement of the exercise bar 30) until the automatic mode reversal command is received from the switching logic 67.

The mode reversal output 69 is connected to the input of a speed and direction programmer, diagrammed in FIG. 7. The implementation of the details of these circuits is well known among those skilled in the art of electronic technology.

FIG. 7 is a functional schematic diagram of a speed and direction programmer, including circuitry for control of acceleration and deceleration rates. In this particular example, the desired "program" is to alternately rotate the system driveshaft 35 clockwise and counterclockwise at independently adjustable speeds in each direction with a single adjustable linear deceleration/acceleration rate at points of direction of rotation reversal.

This is accomplished with a latching digital up/down counter 70, an up/down toggle input 69a of which is continuous with the mode reversal output 69 of the mode reversal circuitry of FIG. 5. The up/down counter 70 either counts up to a maximum or down to a minimum depending upon the signal at its toggle input 69a at a rate established by the R-C time constant of the acceleration-deceleration setting potentiometer 64 and a timing capacitor 71, which are components of a free-running multivibrator 72. Thus, when the mode-reversal circuitry so commands, the output of a digital-to-analog converter 73, which is connected to, and performs an integration function upon, the several outputs of the up/down counter 70, advances gradually from a maximum value to a minimum value, or vice-versa, and holds that value until another reversal is initiated.

The output of the digital-to-analog converter 73 is clamped by clamping diodes 74 and 74a at specific values set by the upward and downward (clockwise and counterclockwise) speed setting potentiometers 62 and 63, which are independently adjustable. These speed setting potentiometers thus limit the excursion of voltage output of the digital-to-analog converter 73 about a voltage midway between maximum and minimum, which point is considered "null", that is, a command established such that the system does not move in either direction.

Thus, a speed and direction output 75 makes electrical excursions about a null value at an adjustable rate between adjustable limits, serving as a combined speed and direction command for system operation. This output is used as a reference signal against which the output of the system tachometer generator 40 (speed and direction sensing means) is compared by the system comparator 16, which initiates the appropriate system compensatory response (powering or braking) to maintain equilibrium. The implementation of the details of this circuitry is well known among those skilled in the art.

FIG. 8 shows a simplified schematic diagram of the utilization of a generator as a proportioned braking means. As was noted in the description of FIG. 2, above, this embodiment of the invention utilizes a single permanent-magnet type servomotor as both a powering and a braking means. Since a very particular sort of braking, namely, proportioned braking, is required in a Proportioned Resistance Exercise Servo System,

the specific approach, namely, feedback shunt regulation, is outlined in FIG. 8.

Here, the servomotor 39 and the tachometer/generator 40 are coupled to the same output shaft 47. As rotating force is applied to the shaft 47, presumably, in this case, by the user 10 in his exercise efforts, both the servomotor 39 and the tachometer/generator 40 behave as generators. As the speed of rotation of the shaft 47 increases, the voltage output of the tachometer/generator 40 also increases, approaching a value established in a voltage reference element 76, the functional analog of the output of the speed and direction programmer outlined in FIG. 7. As this voltage reference value is approached, current begins to flow through a series resistance 77 and a shunt element 78, in this case, Darling-ton-connected power transistors. The shunt element 78 shunts away the current being generated by the servomotor 39 in proportion, therefore, to the speed of rotation of the shaft 47, and a proportioned dynamic braking feedback speed regulation is thereby accomplished. The regulation speed may be adjusted by varying the voltage reference value of the voltage reference element 76. The implementation of the details of this circuitry is well known to those skilled in the art.

FIG. 9 shows a functional schematic diagram of an accumulative work performance display incorporated in the subject exercise servo system to provide to the user 10 feedback information regarding the results of his exercise efforts, such that he may manipulate those efforts in the utilization of the apparatus toward desired objectives. In this particular embodiment, the torque sensing means is the DC permanent-magnet servomotor 39 itself, as both when behaving as a powering device (motor) and a braking device (generator), the torque is proportional to the amount of current flowing through the servomotor 39. This current is measured as a voltage drop across a current sensing resistor 79 in both the powering and braking modes, as the servomotor 39 is being either proportionately driven by conventional feedback regulated powering circuitry 80 or proportionately shunted (as outlined in FIG. 8) by feedback regulated braking circuitry 80. It should be noted here that, as indicated in the description of FIG. 1, effective measurement of work performance is not contingent upon this specific approach to torque sensing; a variety of means such as strain gauges, spring deflection devices, etc., might suitably substitute for the direct current measurement approach outlined here.

The electrical measurement of system torque thus obtained is integrated with a measurement of distance of system movement in the following manner: a multivibrator 81 generates a continuous and constant frequency of pulses as long as its oscillations are not inhibited by a comparator 82. These pulses are counted, divided, and displayed by the digital indicator 52. It should be noted that in the interest of simplicity, only one of the indicators shown in FIG. 4 is shown here, in this case the set indicator. All of the several indicators display appropriate combinations of counts of the output of the same multivibrator 81.

In addition to being counted by the indicator 52 the output pulses of the multivibrator 81 are also counted by a digital counter 83, the several outputs of which are converted to an analog voltage by a digital-to-analog converter 84, that is, an analog voltage is presented to the comparator 82 that is proportional to the number

of pulses generated by the multi-vibrator 81. The multi-vibrator 81 pulses are counted, accumulated, and displayed by the indicator 52 until an analog voltage is developed at the output of the digital to analog converter 84 that is equal to the voltage developed across the current sensing resistor 79, at which time the comparator 82 output changes state and inhibits further oscillation of the multi-vibrator 81. Thus, a display appears on the indicator 52 that is proportional to the system torque, or the force applied by the user.

In the description of FIG. 3, an optical tachometer 41 was described having a light source 48, a disc 46 rotating on the motor shaft 47, and a photodetector 49, in this case a phototransistor. The photodetector 49 develops pulses across a series resistance 85 that are proportional in number to the distance of movement of the exercise bar. These pulses are used to "reset" the digital counter 83, periodically "enabling" the inhibited multivibrator 81 for another series of counts as outlined above. Thus, during each specific small increment of movement of the exercise bar, the force applied to the bar (system torque) is measured once, and the product of force and distance (work) is accumulatively displayed on the indicator 52. The implementation of the details of this circuitry is well known among those skilled in the art.

When the user desires to perform a standard barbell curl, he turns on the master switch 61 and preselects the desired range of movement by adjusting the range setting potentiometers 59 and 60 while viewing the digital indicators 56 and 58 until these indicate numerically the upper and lower reversal points desired. He also preselects the desired speed of movement and acceleration and deceleration rates by adjusting the potentiometers 62, 63 and 64, as required. Assuming that this is the first of several sets and exercises to be performed in the exercise session, the user resets all of the digital performance indicators 50, 51, 52, 53 and 54 by depressing the pushbuttons 52a, 53a, and 54a. Having made these required settings, the user stands erect upon the platform 34, grips the exercise bar 30 with hands spaced equidistant from its center, and begins the exercise by applying concentric contractions of the biceps muscles to raise the exercise bar 30 to shoulder level. (It is assumed here that, at the start of the exercise, the exercise bar 30 rests at some point lower than shoulder level, or the upper limit set point, as, during the course of adjustment of the range setting potentiometers 59 and 60 previous to beginning the exercise, should the exercise bar 30 have rested above the upper limit set point, power would have been applied through the system to bring the exercise bar 30 below that point.)

The force of the concentric contractions of the user's biceps muscles is transmitted to the cables 32 through the bearings 31 attached to the exercise bar 30. This force applied to the cables 32 unwinds them from the drums 33, applying rotational torque to the system driveshaft 35 and therefore simultaneously the servo motor 39, the tachometer-generator 40, the optical tachometer 41, and the position sensing potentiometer 38 via the gearbox 37, and causing all of these components to rotate.

When the force applied by the user is sufficient to cause these system components to rotate at the preselected speed, the voltage output of the tachometer-generator 40 turns on the shunt element 78 across the

output of the servomotor 39, now behaving as a generator, thereby applying a dynamic braking force in opposition to and in proportion to the force applied by the user, such that the preselected speed is not exceeded. Thus, a proportioned exercise resistance is provided against the concentric contractions of the user's biceps muscles as he raises the exercise bar 30 toward his shoulders and the upper limit setpoint at the preset regulation speed.

While the user is raising the exercise bar 30 to shoulder level, the performance display 42 accumulates counts on the digital indicators 50, 52, 53 and 54, but not on the digital indicator 51 which is in a "hold" mode, at a rate proportionate to the product of distance of movement and applied force, that is, in proportion to the amount of work being done by the user. To monitor his instantaneous efforts, the user observes the rate of count accumulation, these counts being derived through the digital integration of electrical signals from the current sensing resistor 79, which are proportional to the applied force, and the optical tachometer 41, which are proportional to the distance of movement.

When the user has moved the exercise bar 30 to the upper limit set point, which presumably coincides with shoulder level, the voltage output of the position sensing potentiometer 38 just exceeds that of the upper limit range setting potentiometer 59, and this difference is sensed by the upper limit comparator 65, which via the switching logic 67 and memory element 68 causes the up-down counter 70 to count down at a rate preset by the acceleration setting potentiometer 64. The digital-to-analog converter 73 converts the output of the descending up-down counter 70 to a descending analog voltage, the voltage reference 76 in the braking circuitry.

Assuming that the system driveshaft 35 is still rotating at the preset regulation speed, it can be seen that the difference between the output of the tachometer-generator 40 and the voltage reference 76 thus becomes progressively larger, turning on the shunt element 78 more strongly and increasing the dynamic braking forces so applied to gradually, at the rate preset in the acceleration-deceleration rate setting potentiometer 64, decelerate the upward movement of the exercise bar 30.

As the exercise bar 30 and thus the driveshaft 35 and other system rotating components decelerate in the present direction, it can be seen that a reduced speed in the present direction is reached, below which shunted current braking becomes ineffectual. At this point, signaled by a consequent increasing difference between the outputs of the tachometer-generator 40 and the digital-to-analog converter 73, the system comparator 16 applies power to the servo motor 39 to cause it to continue to apply gradually increasing braking forces in a "plugging" mode until rotation in the present direction ceases, and then to gradually increase speed of rotation in the opposite direction until the limit preset with the downward speed setting potentiometer 63 is achieved, at which speed the output of the digital-to-analog converter 73 has ceased its downward excursion and the system functions to maintain the output of the tachometer-generator 40 at a constant level in the new direction.

Thus, while the user's biceps muscles have continued to apply force to the exercise bar 30 beyond the upper

limit set point, the system has "overpowered" him, gradually halting the upward movement of the exercise bar 30, reversing its direction of movement, and gradually increasing its rate of movement downward until the preset regulation speed in that direction is achieved. In the downward direction, proportioned power is continuously applied to the servomotor 39, winding the cables 32 upon the drums 33 attached to the driveshaft 35, and pulling the exercise bar 30 downward at regulation speed against the forces of eccentric contractions of the biceps muscles applied by the user in an upward direction. The harder the user pulls against the downward movement of the exercise bar 30, the more power is applied by the system to maintain preset regulation speed, and thus a proportioned exercise resistance is provided against the user's efforts.

During this downward movement, the user may monitor his efforts on the performance display 42 upon which is presented a continuing accumulation of the amount of work being done on all but the one digital indicator 51.

When the exercise bar 30, now moving in a downward direction, reaches the lower limit set point, previously set with the lower limit range setting potentiometer 60, which presumably coincides with a point in the biceps curl movement at which the arms are nearly fully extended downward, the voltage output of the position sensing potentiometer 38 drops just below that of the lower limit range setting potentiometer 60, and this difference is sensed by the lower limit comparator 66, which, via the switching logic 67 and the memory element 68 causes the up-down counter 70 to count up at the rate preset with the acceleration potentiometer 64, and the digital-to-analog converter 73 converts the output of the ascending up-down counter 70 to an ascending analog voltage, the voltage reference for the system comparator 16. This process is identical to that which previously occurred at the upper limit point of reversal of direction of movement, except in reverse; that is, in proportion to the force being applied by the user, when the exercise bar 30 reaches the lower limit point of reversal, power is gradually removed and then braking is applied, first strongly, and then gradually diminishing until the exercise bar 30 is again moving upward at the preset regulation speed, thus effecting a re-reversal of direction of movement with controlled deceleration in the present downward direction and controlled acceleration in the new (original, upward) direction.

Once the lower limit reversal has been completed, the system again functions in the shunt regulation mode as outlined above, providing a proportioned exercise resistance against the concentric contractions of the user's biceps muscles as he exerts effort to move the exercise bar 30 upward again toward the upper limit set point. It may be seen, therefore, that the system operates in a continuous reciprocating fashion between the upper and lower limit set points as long as the user exerts, or is capable of exerting, sufficient upward force on the exercise bar 30 to move the system in the upward direction to the upper limit set point.

It will be recalled that during both the upward and downward movements of the first repetition of the biceps curl described above, a display of the amount of work being done has been accumulating on all of the digital indicators 50, 52, 53 and 54 of the performance display 42, but not on the digital indicator 51, which has been on hold, is reset to zero and enabled, while the

other rep indicator is placed on hold for the duration of the next complete repetition. At the present point, then, after the completion of the first repetition, the digital indicator 50 displays the amount of work done in the first repetition, against which the user may compare the amount of work he is doing in the second repetition, which is now accumulating on the other rep digital indicator 51. The other digital indicators 52, 53, and 54 continue to accumulate the sum of all repetitions.

At the end of the second repetition, the first rep digital indicator 50 will reset to zero, enable, and begin accumulating the amount of work done in the third repetition, while the other rep digital indicator 51 will retain the amount of work done in the second repetition for comparison purposes. Thus, the rep digital indicators 50 and 51 alternately accumulate and hold a display of the amount of work done in the present and previous repetitions of the exercise, respectively, while the other digital indicators 52, 53, and 54 accumulate and display the sum of the amount of work done in all repetitions.

Assume that the user has established for himself the objective of completing three sets of the biceps curl exercise at this session, with a specific period of rest between sets, with maximal effort, known from previous experience to yield a peak of about 100 "units" of work in a single repetition, to be exerted in all repetitions, and with repetitions to be continued in each set until exhaustion, and with the overall goal of accumulating a total of 2000 units of work for the exercise. During each repetition of the first set, he observes the alternating rep displays and attempts to maximize his effort such that each repetition's total exceeds 100 units, if possible, or, at least, exceeds the previous repetition as total. Muscle fatigue, of course, prohibits his accomplishing this in all repetitions, and he might, for example, accumulate these totals for the first set: 80, 88, 103, 92, 97, 66, 41, 38, 17, 10, 12, 8. Thus, in the 12 sequential repetitions of the first set of biceps curls, he has totaled 652 units of work, just under one-third of his total objective for the exercise, and this total is displayed on the set, "exercise", and "session" digital indicators 52, 53, and 54. During his rest period, he pushes the set display reset pushbutton 55 on the control box 43 to reset the set digital indicator 52 to zero (the exercise and session digital indicators 53 and 54 retain the 652 count) and contemplates the obvious implication of his first set performance, namely, that if he is to achieve the overall objective of a total of 2000 units, he will have to try significantly harder in his second set than he did in the first, as he known from prior experience that the third set will yield far less than one-third of the total for the exercise, due to the limitations imposed by fatigue.

At the end of the second set, the set digital indicator 52 will display his total for the second set only, while the exercise and session digital indicators 53 and 54 will display the total of both sets. Again, between sets, the user will reset the set indicator 52 to zero. At the end of the third set, the set digital indicator 52 will display his total for the third set only, while the exercise and session digital indicators 53 and 54 will display the total for all sets.

Since at the end of the third set, the user will have completed all desired sets of the barbell curl, he will reset both the set and exercise digital indicators 52 and 53 in preparation for the next exercise, possibly after recording his performance data on a chart for future

reference and progress assessment. It should be noted here that other, or supplementary means of performance parameter display and recording might be well suited for application here. For example, a digital printer or computer memory might record the totals for each repetition, set, exercise, and/or session for reference and analysis. Thus, it may be seen that the performance display 42 described herein serves simultaneously to permit the user to analyze the results of his efforts and to motivate himself toward the accomplishment of specific exercise objectives. It should be noted here, however, that the objectives cited are for example only; a variety of objectives are possible with the system, including specific sub-maximal amounts of work per repetition, specific or maximal totals for limited numbers of sets, varying periods of rest between sets or repetitions, varying speeds and ranges of movement, etc.

Let us now suppose that the user desires to perform the regular knee-bend as his second and final exercise in this session. Having previously determined the desired speed, acceleration, and range of movement for this exercise, he adjusts the appropriate potentiometers 59, 60, 62, 63, and 64 on the control box 43, stands upon the platform 34, bends his knees, places the exercise bar 30 across his shoulders behind his neck, and, keeping his back as straight as possible, straightens his legs to stand erect, exerting an upward force on the exercise bar 30. In this exercise, the system functions in the same manner as outlined for the barbell curl, providing the appropriate amount of resistance throughout the movement, with the upper reversal of movement occurring when the body comes erect, and the lower reversal occurring when the thighs are approximately parallel to the platform 34. Again, the user observes the performance display 42 during the performance of the exercise and adjusts his efforts toward certain desired objectives, resetting the set digital indicator 52 between sets.

At the end of his several sets of knee-bends, the user may observe and record his cumulative work total for this exercise on the exercise digital indicator 53, as well as for both his curls and knee-bends on the session digital indicator 54. After resetting the set and exercise digital indicators 52 and 53, the user might go on to perform any number of desired exercises in the session in similar fashion. The session digital indicator 54 might be reset to accumulate the amount of work done in any sequential group of exercises, "cancelling out" those previously completed. Clearly, alternative performance indicating systems might be devised, for example, to accommodate several users using a single apparatus simultaneously, as it is common practice for two or more "training partners" to utilize the same apparatus, one exercising while the other is resting.

The specific exercises described above are cited for example only; the apparatus is well suited to a variety of common exercises such as standing press, rowing, bench press, calf raises, etc. as well as highly specialized exercises, some of which require additional or alternate user-interfacing means.

To those skilled in the art to which this invention relates, many changes in construction and widely differing embodiments and applications of the invention will suggest themselves without departing from the spirit and scope of the invention. The disclosures and the de-

scription herein are purely illustrative and are not intended to be in any sense limiting.

I claim:

1. An exercise apparatus including in combination:
 - resistance means for providing in each of two opposite directions exercise resistance proportioned to the force applied by the user,
 - reversing means connected to said resistance means for causing said resistance means to reciprocate automatically between two predetermined limits,
 - means connected to said resistance means for applying controlled acceleration to said resistance means as it approaches and departs from each of said limits at which the direction is automatically reversed, and
 - means connected to said resistance means for displaying the user's performance.
2. An exercise apparatus including in combination:
 - resistance means for providing in each of two opposite directions exercise resistance proportioned to the force applied by the user,
 - reversing means connected to said resistance means for causing said resistance means to reciprocate automatically between two predetermined limits, and
 - means connected to said resistance means for displaying the user's performance.
3. An exercise apparatus comprising
 - a user force applied reaction device,
 - movement sensing means connected to said device for sensing the distance moved by said device,
 - force sensing means connected to said device for sensing the force applied to said device by the user,
 - plural display means connected both to said movement sensing means and to said force sensing means for simultaneously and adjacently displaying in an accumulative fashion the amount of work performed in each exercise repetition as the product of the outputs of force and distance, and
 - holding means for holding the display to enable comparison with the immediately succeeding repetition.
4. An exercise apparatus comprising
 - a movable device adapted for driving relation with a user,
 - resistance means connected to said device for providing said device with exercise resistance by supplying driving power to said device in one direction of its movement and by supplying braking force to said device in the opposite direction of its movement,
 - means connected to said device for automatically reversing the direction of movement of said device at each of two preset limits, and
 - means connected to said device for displaying the user's performance with said device.
5. A proportional resistance exercise device, including in combination:
 - a drive shaft,
 - user interfacing means connected to said drive shaft in driving relation thereto and through which the user applies force to said drive shaft and vice versa,
 - braking means for applying braking force to said drive shaft as it is moved in a first direction by user-

exerted force on said interfacing means, in a braking mode,
 power means for applying power to drive said drive shaft in a second direction and thereby to exert force on said interfacing means, in a power mode,

limiter means operatively connected to said drive shaft for limiting the movement of said shaft in said first direction to its reaching a first limit and for limiting the movement of said shaft in said second direction to its reaching a second limit,

direction reversal means connected to said braking means, said power means, and said limiter means for automatically ceasing to apply said braking means to said drive shaft at said first limit and thereafter applying said power means thereto and for automatically ceasing to apply said power means to said drive shaft at said second limit and thereafter applying said braking means thereto, and

display means operatively connected to said drive shaft for displaying to the user chosen parameters relating to the exercises being done.

6. A proportional resistance exercise device, including in combination:

a rotary drive shaft,

user interfacing means connected to said drive shaft in driving relation thereto and through which the user applies force to rotate said drive shaft in a first direction and which applies force to act on the user in a second direction of rotation of said shaft,

braking means for applying braking force to said drive shaft while it is rotated in said first direction by user-exerted force on said interfacing means, in a braking mode,

power means for applying power to rotate said drive shaft in said second direction and thereby to exert force on said interfacing means, in a power mode,

limiter means for limiting the rotation of said shaft in said first direction to prevent rotation beyond a first limit and for limiting the rotation of said shaft in said second direction to prevent rotation beyond a second limit,

direction reversal means for automatically ceasing to apply said braking means to said drive shaft at said first limit and immediately thereafter applying said power means thereto to move it in said second direction and for automatically ceasing to apply said power means to said drive shaft at said second limit and immediately thereafter applying said braking means thereto while enabling said shaft to rotate in said first direction.

braking programming means connected to said braking means for changing the braking force during said braking mode according to a predetermined program,

power programming means connected to said power means for changing the power applied to said drive shaft during said power mode, according to a predetermined program,

feedback means sensing the force applied by said user to said drive shaft via said interfacing means, said feedback means being connected to said power means and to said braking means for regulating the driving force applied to said shaft during said power mode and the braking force applied

- during said braking mode, altering both said programming means during use according to the force applied by the user to said drive shaft, and display means operatively connected to said drive shaft for displaying to the user chosen parameters relating to the exercises being done. 5
7. The device of claim 6 having means for changing the location of each of said limits.
8. A proportioned resistance exercise servo system, including in combination: 10
- user interface means for connection to a user,
 - movable means connected to said interface means in driving relation therewith so that either of said means can drive the other,
 - a first servo loop connected to said movable means and having a feedback means for opposing the force applied by said user to said interface means in proportion to said applied force, 15
 - a second servo loop connected to said first servo loop and having reversal means for changing the direction of said movable means and the type of force applied to it by said first servo loop at each of two extreme positions of said movable means, 20
 - a third servo loop connected to said first servo loop providing a user-observable display of selected performance parameters, and 25
 - a fourth servo loop connected to said first servo loop having means for comparing the rates of acceleration of movement of said movable means in each direction with predetermined desired rates and for controlling said actual rates accordingly. 30
9. A proportioned resistance exercise servo system, including in combination:
- user interface means for connection to a user,
 - a rotatable shaft, connected to said interface means in driving relation therewith so that shaft can drive said interface means and vice versa, 35
 - a first servo loop connected to said shaft and having feedback means for opposing the force applied by said user to said interface means in proportion to said applied force by braking said shaft in one direction of rotation and by positively driving said shaft in the opposite direction of rotation, 40
 - a second servo loop connected to said first servo loop and having reversal means for automatically changing the direction of rotation of said shaft and changing from braking to driving at one extreme and from driving to braking at a second extreme position of said shaft, 45
 - a third servo loop connected to said first servo loop providing a user-observable display of selected performance parameters obtainable from said shaft and said first servo loop, and 50
 - a fourth servo loop connected to said first servo loop having means for comparing the acceleration of rotation of said shaft during the entire rotation in each direction with predetermined desired rates and for controlling the actual acceleration accordingly. 55
10. A proportioned resistance exercise servo system, including in combination: 60
- a rotary drive shaft,
 - user interfacing means connected to said drive shaft in driving relation therewith, so that movement of the one results in movement of the other, 65

- position sensing means sensing the position of said drive shaft,
 - powering means,
 - speed-reducing means connected to said powering means and connected to said drive shaft for driving said shaft in a power mode,
 - braking means connected to said speed-reducing means for exerting a braking force therethrough on said shaft in a braking mode,
 - mode reversal means connected to said position sensing means and to said powering means and to said braking means for changing the operation of said drive shaft from the power mode to the braking mode at one position and for changing it from the braking mode to the power mode at another position,
 - speed and direction sensing means connecting to said speed reducing means,
 - a speed and direction programmer connected to said mode reversing means,
 - comparing means for continuously comparing signals from said speed and direction sensing means with signals from said speed and direction programmer and connected to said power means and to said braking means for changing instantaneously the power applied during the power mode and to braking applied during the braking mode,
 - torque sensing means connected to said drive shaft for sensing the torque therein, and
 - performance display means connected to said torque sensing means for displaying to the user the torque thereof.
11. An exercise apparatus comprising
- a user-operated reaction device,
 - movement sensing means connected to said device for sensing the distance moved by said device,
 - force sensing means connected to said device for sensing the force applied to said device by the user,
- plural display means connected both to said movement sensing means and to said force sensing means for (1) displaying in an accumulative fashion the amount of work performed in a current exercise repetition as the product of the outputs of force and distance and (2) simultaneously and adjacently displaying the total amount of work performed in the immediately preceding exercise repetition.
12. An exercise apparatus comprising
- a movable user force applied reaction device,
 - movement sensing means connected to said device for sensing the distance moved by said device,
 - force sensing means connected to said device for sensing the force applied to said device by the user,
- plural display means connected both to said movement sensing means and to said force sensing means for simultaneously and adjacently displaying in an accumulative fashion (1) the amount of work performed during a given exercise repetition as the product of the outputs of force and distance and (2) the total amount of work during the series of repetitions of the given exercise.
- * * * * *