

# United States Patent

[11] 3,565,020

[72] Inventors **Robert W. Schier;**  
**Larry F. Odar, Northbrook, Ill.**  
 [21] Appl. No. **744,856**  
 [22] Filed **July 15, 1968**  
 [45] Patented **Feb. 23, 1971**  
 [73] Assignee **Krueger Metal Products, Inc.**  
**Green Bay, Wis.**  
**a corporation of Wisconsin**

2,639,817	5/1953	Ehret.....	108/152
2,876,910	3/1959	Morton .....	211/153
3,114,575	12/1963	Eames et al.....	297/248
3,224,081	12/1965	Richter.....	211/153
3,358,847	12/1967	Magnuson.....	211/177
1,846,567	2/1932	Murray.....	182/228

Primary Examiner—Francis K. Zugel  
 Attorney—Wheeler, Wheeler, House & Clemency

[54] **COAT RACK**  
**5 Claims, 9 Drawing Figs.**

[52] U.S. Cl. .... **108/152,**  
 108/29, 211/153, 211/177  
 [51] Int. Cl. .... **A47f 5/00**  
 [50] Field of Search..... 108/152,  
 108, 29, 109; 211/153, 177, 182, 123; 248/250,  
 68, 68 (CB); 297/248 (Cursory)

[56] **References Cited**  
**UNITED STATES PATENTS**  
 2,091,599 8/1937 Larson et al. .... 248/250  
 2,355,742 8/1944 Morehouse..... 248/68(CB)

**ABSTRACT:** Interconnected uprights have forwardly projecting arms each of which includes a shelf-supporting section and a cap section interlocking with the first section and the shelf. The shelf comprises end members resting on shelf-supporting surfaces of the arms and spaced tubes of elliptical cross section welded at their ends within correspondingly shaped openings in the end members. Fittings have portions telescoped into the respective uprights and other portions telescoped into legs, the fittings and legs having feet for supporting the uprights from the floor.

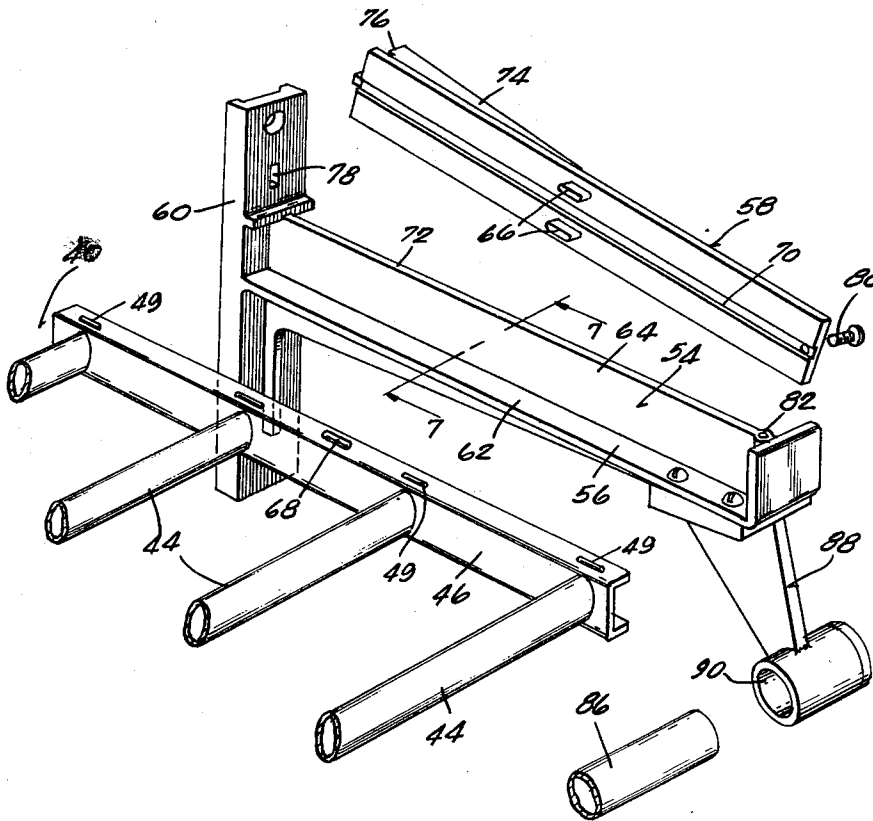

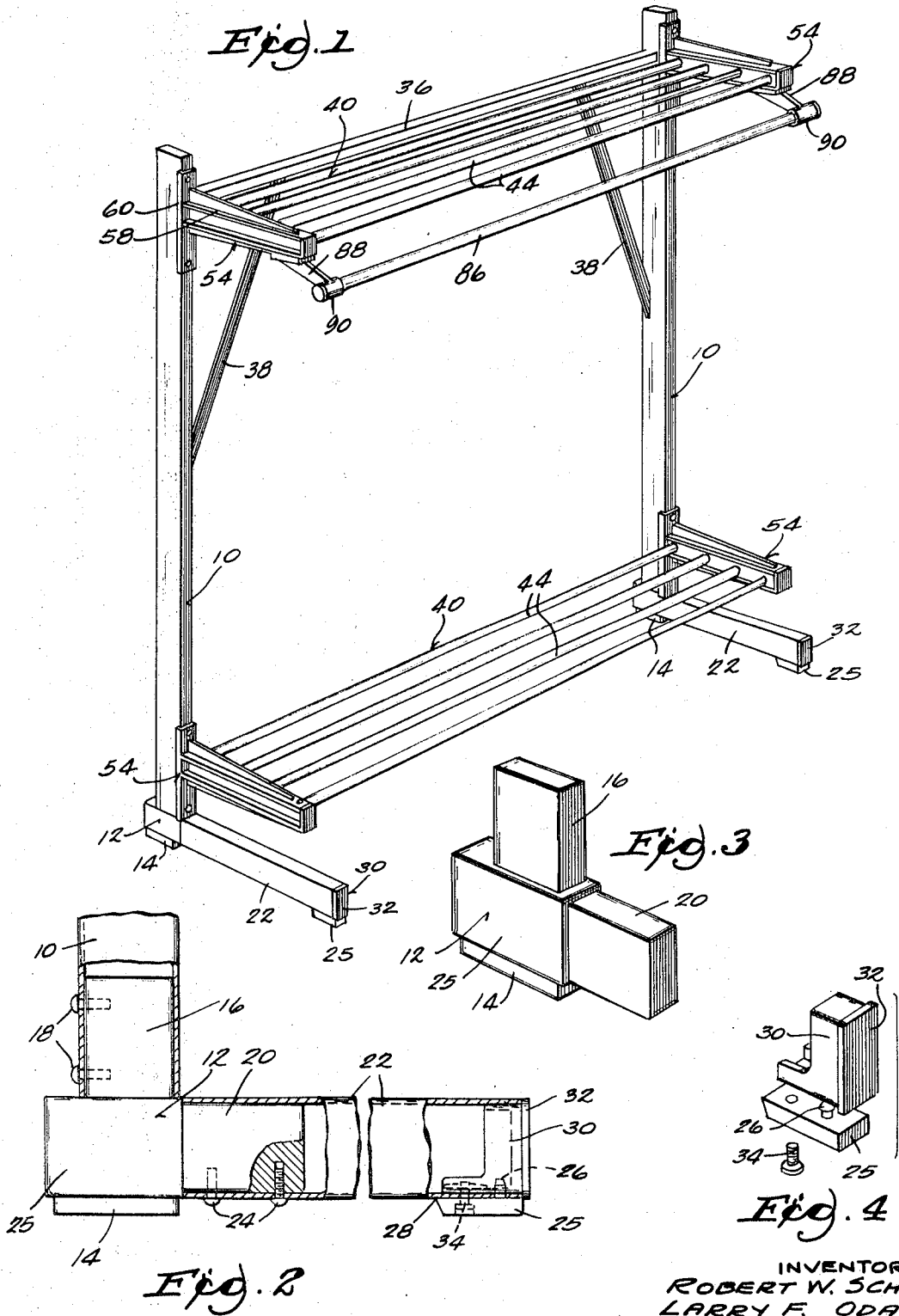

INVENTORS  
ROBERT W. SCHIER  
LARRY F. ODAR

BY *Wheeler, Wheeler, House & Clemency*  
ATTORNEYS

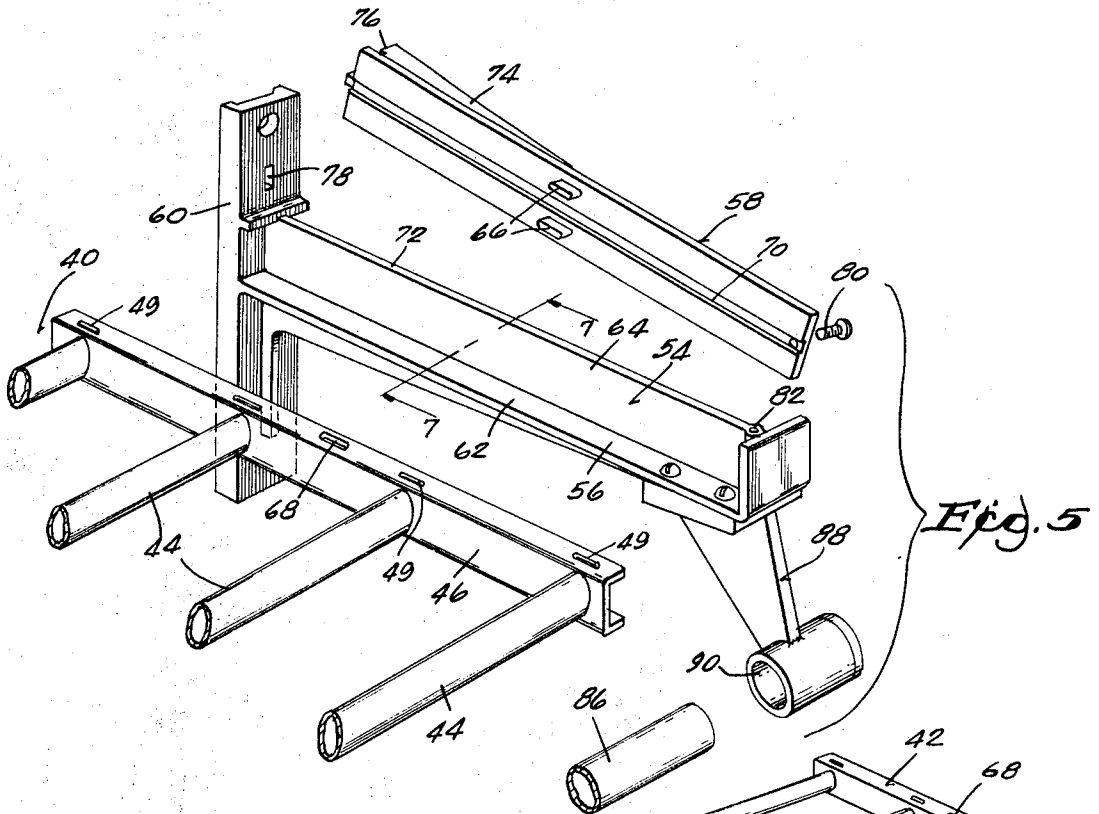

*Fig. 5*

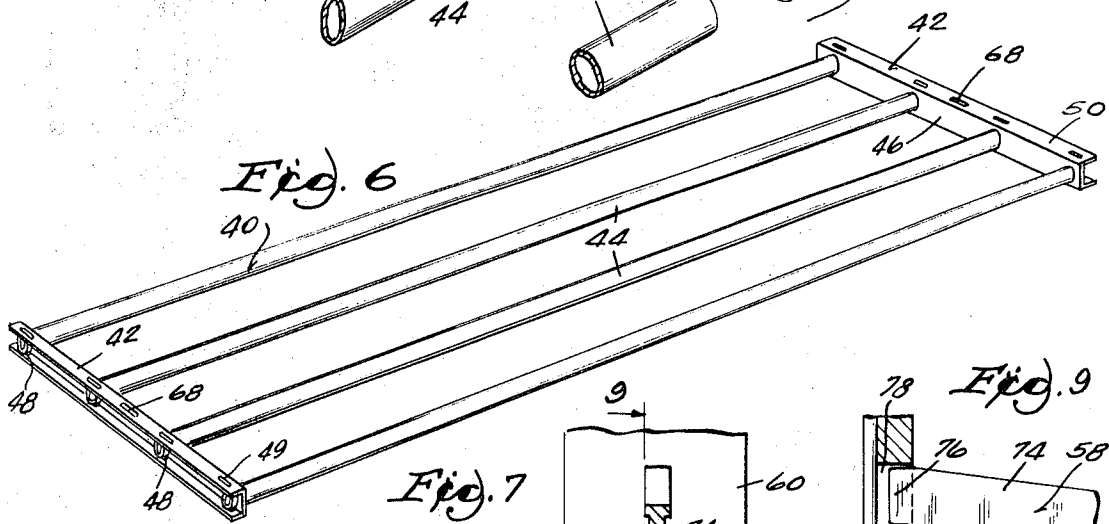

*Fig. 6*

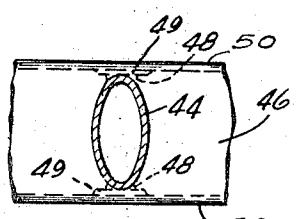

*Fig. 8*

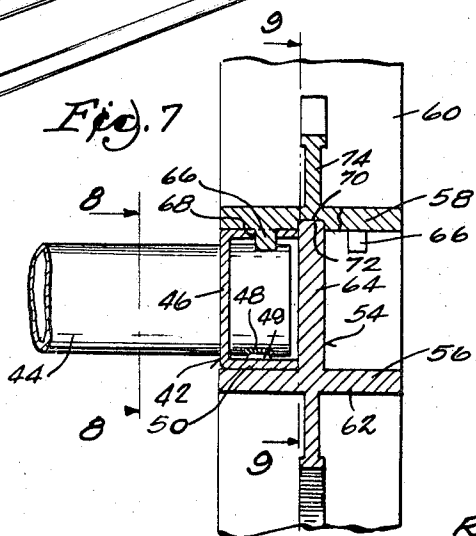

*Fig. 7*

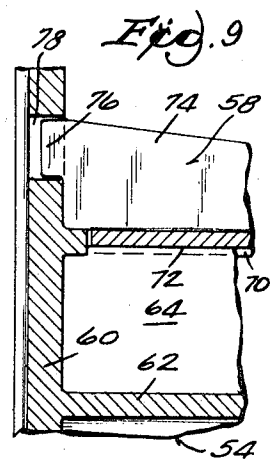

*Fig. 9*

INVENTORS  
 ROBERT W. SCHIER  
 LARRY F. ODAR  
 BY *Wheeler, Wheeler, House & Clemency*  
 ATTORNEYS

## COAT RACK

## BACKGROUND OF THE INVENTION

A coat rack embodying the present invention is peculiarly adapted to be shipped in knockdown form and assembled with maximum facility to achieve a structure which is rigid while in use. The various parts are connected by interlocking portions such as to require only a single screw at each assembly point. The structure is designed for end to end connection with like components, using a single one of the uprights to support contiguous ends of consecutive racks.

## SUMMARY OF INVENTION

A knockdown coat rack has generally horizontal leg members connected by special fittings with the lower end portions of uprights which have elevated bars connecting them with each other and to which braces are attached. The fittings and end caps on leg members provide feet to hold the leg members and uprights free of the floor.

At any desired points on the uprights, there are fastened anchorage portions of forwardly projecting arms having shelf-supporting surfaces and having complementary cap elements which interlock with the mounting portions and with the shelves and are screwed to the first arms to maintain the assembly. There may be as many shelves as desired. The relation between the arm and its cap and the end of the shelf is a separately claimed subcombination hereof.

The shelves themselves are unusual, each comprising end members which are preferably channels with outwardly directed flanges and with webs provided with elliptical openings with their major axes vertical and in which tubes of corresponding cross section are disposed and resistance-welded to ribs with which the flanges are provided. The flanges conceal the welds when the ends of the shelf are mounted on the shelf-supporting portions of the forwardly projecting arms of the rack. The shelf per se is a separately claimed subcombination hereof.

Optionally, the arms may be provided with brackets having sockets to receive a bar upon which coat hangers may be suspended.

## BRIEF DESCRIPTION OF DRAWINGS

FIG. 1 is a view in perspective of a coat rack embodying the invention.

FIG. 2 is an enlarged fragmentary detail view partially in side elevation and partially in section showing the lower end of one of the uprights, a fitting provided with a foot and a leg connected by such fitting with the upright projecting forwardly therefrom and terminally provided in separable fashion with another foot.

FIG. 3 is a detail view in perspective showing the fitting referred to in connection with FIG. 2.

FIG. 4 is a detail view in perspective showing a closure cap for the end of the leg and in relatively separated position, the forward foot illustrated in FIG. 2.

FIG. 5 is a detail view illustrating in perspective mutually separated and relatively angularly displaced portions of one of the forwardly projecting arms, the shelf and coat hanger bar being fragmentarily illustrated.

FIG. 6 is a view on a reduced scale as compared with FIG. 5 showing the shelf assembly.

FIG. 7 is a view on a greatly enlarged scale showing in cross section on the plane indicated at 7-7 in FIG. 5 one of the arms and a portion of the shelf interlockingly connected therewith.

FIG. 8 is a view taken in section on the line 8-8 of FIG. 7.

FIG. 9 is a view taken in section on the line 9-9 of FIG. 7.

## DESCRIPTION OF PREFERRED EMBODIMENT

A post or upright 10 at each end of the coat rack comprises a tube of rectangular cross section. Each tube is mounted on one of the fittings 12 as best shown in FIGS. 2 and 3. Each of the fittings 12 is a casting having a foot 14, an upright boss 16

telescoped into one of the posts 10 and anchored by screws 18 and a forwardly projecting boss 20 telescopically engaged in the leg 22 and anchored by screws 24. It will be observed that the casting 12 has a body portion 25 against which the respective ends of upright 10 and leg 22 are seated when fully telescoped onto the respective bosses 16 and 20.

Each leg 22 projects forwardly from the respective casting 12 which supports the respective post or upright 10. The leg is provided at its outer end with a foot 25 which has a headed stud 26 projecting through the wall 28 at the bottom of leg 22. A screw 34 passes through an opening in the foot and a corresponding opening in the leg to be threadedly engaged with a closure plug 30. This plug includes cap 32 for the free end of the leg 22. When the plug 30 is inserted as shown in FIG. 2, the application of foot 25 engages the headed dowel 26 with the plug to provide an interlock between the parts which is maintained effective by the single screw 34 inserted through the lower wall 28 of leg 22 into threaded engagement with the plug 30.

The structure thus far described is duplicated at both ends of the coat rack.

At some elevated level, a cross member 36 connects the upper ends of the posts, being braced therefrom at 38. Preferably, though not necessarily, the cross member 36 is at the level of a shelf generically designated 40. The shelf is a subassembly unitarily having terminal channels 42 connected by spaced tubes 44, which are preferably of elliptical cross section to achieve maximum load bearing capacity in relation to the amount of material used. The web portion 46 of each terminal channel has an elliptical opening into which the elliptical tube 44 is received. Resistance welds 48 anchor each of the tubes to ribs 49 on the flanges 50 of the terminal channel 42 (FIGS. 6 and 8).

Projecting forwardly from each of the uprights or posts 10 is a shelf-supporting arm 54 which comprises a base portion 56 and a cap portion 58 as best shown in FIGS. 5 and 7.

The base portion 56 is integral with a mounting member 60 screwed to the upright 10. There are shelf-supporting flanges at 62 at opposite sides of a central vertical web 64. Because they project oppositely as shown in FIG. 7, a single bracket arm can support contiguous ends of two consecutive shelves if desired.

The cap member 58 is shown in assembled position in FIG. 7 and is shown in a relatively rotated position in FIG. 5 to expose the dowels 66 which project downwardly from the cap member in positions to engage in the correspondingly shaped sockets 68 with which the top flanges of the respective shelf end channels 42 are provided. The parts are shown in FIG. 7 as interlockingly engaged.

There are additional interlocking features. The underside of the cap member 58 has a channel 70 which fits the top margin 72 of the central web 64 of the bracket arm as best shown in FIG. 7.

The cap member has its own central web 74 which, as shown, is in the same plane as the web 64 of the lower bracket arm member 54. The web 74 of the cap member 58 has a projecting terminal 76 which interlocks with a socket provided at 78 in the mounting member 60 as best shown in FIG. 9. The result is an extremely stable construction requiring for maintenance of the entire locking construction as herein described only a single screw at 80 which penetrates the cap member at its outer or free end to engage a screw-threaded opening at 82 in the bracket arm member 54.

An optional provision is a bar 86 for coat hangers. When such a bar is desired, subbrackets 88 are screwed to the under sides of the respective arm members 54 to project downwardly and/or forwardly to carry the sockets 90 which receive and retain the ends of bar 86 (FIGS. 1 and 5).

Since the legs and arms as well as the connecting cross member 36 and the braces 38 are all readily detachable from the uprights 10, and since the preassembled shelves 40 are substantially planiform, it will be apparent that the various elements of the coat rack can be compactly packaged in a sub-

stantially flat container for shipment and storage. The interlock between the various parts and the relatively small number of screws required to maintain the parts interlockingly engaged are factors which facilitate the erection and assembly of the coat rack and its permanent maintenance in rigid operative condition. The skeletonized construction of the arms and legs, as well as the elliptical form of the tubes used to make the shelf or shelves are advantageous in reducing expense and shipping weights.

While only one shelf has been described, it will be understood that the lower shelf illustrated in FIG. 1 and additional shelves at the top of the coat rack may be constructed and installed in the same manner as has been described here.

I claim:

1. In a coat rack having an upright post and also having a shelf, the subcombination which comprises an arm having means for connecting it with the post in a position to project therefrom, said arm having a longitudinal web and a shelf-supporting seat at one side of the web, and means spaced above said seat for holding a shelf thereon, said means comprising a cap element having an interlock connecting one of its ends with the arm, and having a screw connecting its other end to the arm, the arm having a terminal mounting portion provided with a socket and the cap element having a projection engaged in the socket and constituting said interlock, the said cap element having a channel in which the longitudinal web of said arm has a marginal portion engaged.

2. In a coat rack comprising end posts of generally rectangular tubular cross section, fittings having body portions with which the lower ends of said posts are engaged and having feet supporting the respective posts, an arm projecting forwardly from each post, each arm having a mounting provided with means connecting it with the post and each arm having a shelf seat, a shelf having its respective ends mounted on the respective shelf seats of said arms, the shelf comprising end members and connecting tubes attached at their ends to said end members, cap elements mounted on each arm and having interlocking engagement with respective mountings and extending across the respective end members for holding the respective end members to the respective shelf seats, and means connecting each of the cap elements to its respective arm at a point remote from its respective post, each said arm including a

generally upright longitudinal web having an upper margin with which the respective cap element has a channel interlockingly engaged, the respective cap elements having dowels and the end members of the shelf having sockets with which the respective dowels are interlockingly engaged.

3. A coat rack comprising end posts, means for maintaining the end posts upright and comprising legs connected therewith, arms projecting forwardly from the end posts and each having a terminal mounting portion provided with fastening means for detachably securing it to one of the posts, each said arm having a longitudinally extending vertical web on one side of which the arm is provided with a seat, and a detachable cap portion for each arm engaged with said web and having means interlocking it at one end with the terminal mounting portion of the arm, a shelf having an end portion mounted on said seat, the cap portion having a dowel for which the shelf portion has a socket, and means for connecting the outer end of the cap portion with said arm to maintain the dowel engaged in the socket.

4. In a coat rack, the combination with a shelf comprising spaced ends and supports connected to said ends and spanning the space therebetween, of mounting arms having means for their support and spaced to receive the shelf, said arms having shelf-carrying flanges projecting toward each other and on which the respective shelf ends rest, each said arm having a cap element in detachable connection with the respective arm and opposed to the respective arm flange and bearing in pressure engagement with the respective shelf end, and screw-threaded means for urging each cap element toward the respective shelf end for maintaining said pressure engagement and clamping said end between the cap element and the opposed flange, each said shelf end comprising a channel disposed on its side and having a web portion from which the supports project and further having vertically spaced laterally projecting flange portions whereof one is engaged with one of said shelf-carrying flanges and the other is lockingly engaged by said cap element.

5. A coat rack combination according to claim 4 in which the cap element and the channel flange engaged thereby have interlocking dowel and socket means held interconnected by said pressure engagement.

45

50

55

60

65

70

75