

No. 643,047.

Patented Feb. 6, 1900.

E. H. EISENHART.

CONTINUOUS MATCH MAKING AND BOXING MACHINE.

(No Model.)

(Application filed Apr. 25, 1898.)

16 Sheets—Sheet 1.

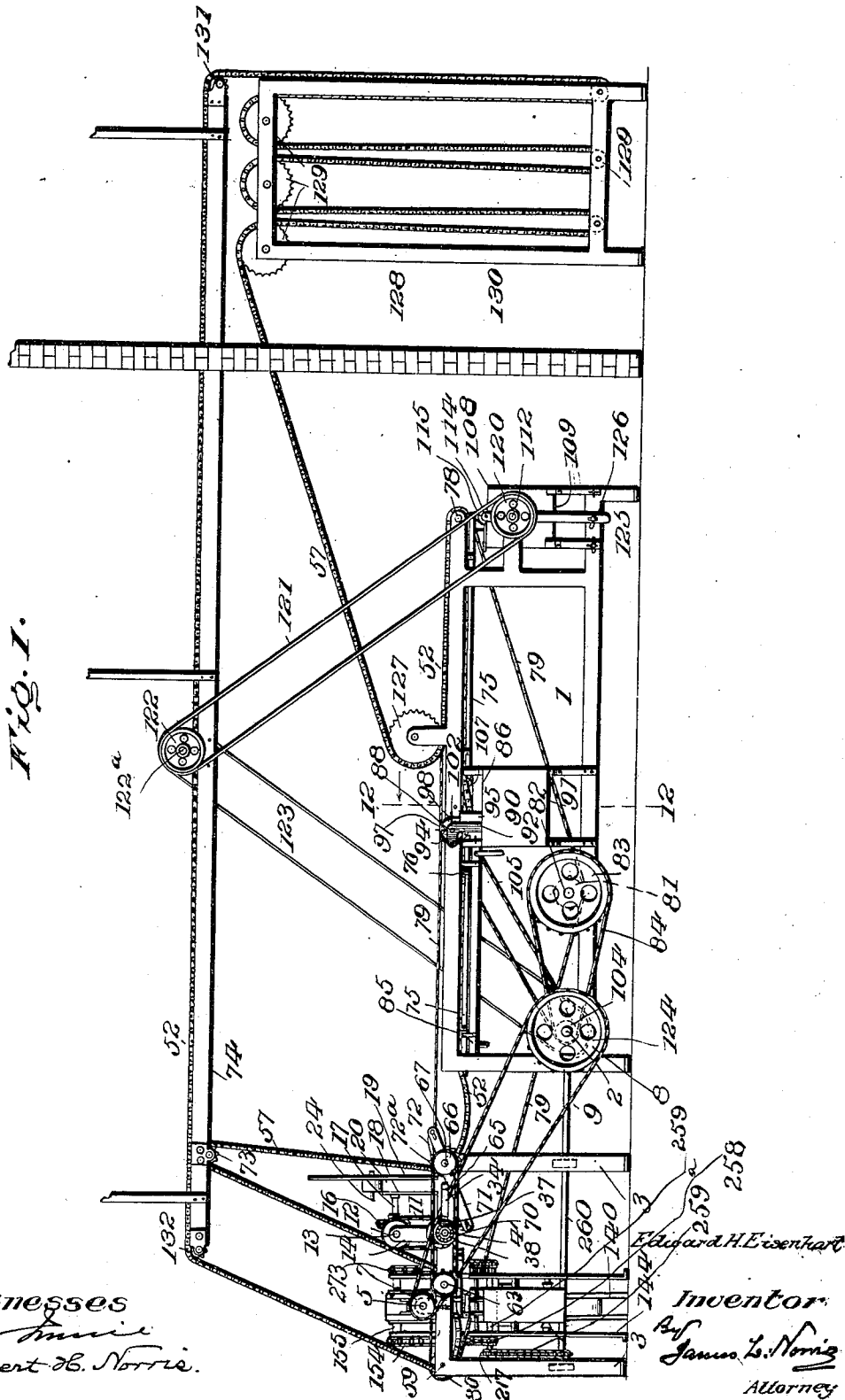

Witnesses
James L. Norris
Albert B. Norris

E. H. Eisenhart
 Inventor
James L. Norris
 Attorney

E. H. EISENHART.

CONTINUOUS MATCH MAKING AND BOXING MACHINE.

(Application filed Apr. 25, 1898.)

(No Model.)

16 Sheets—Sheet 2.

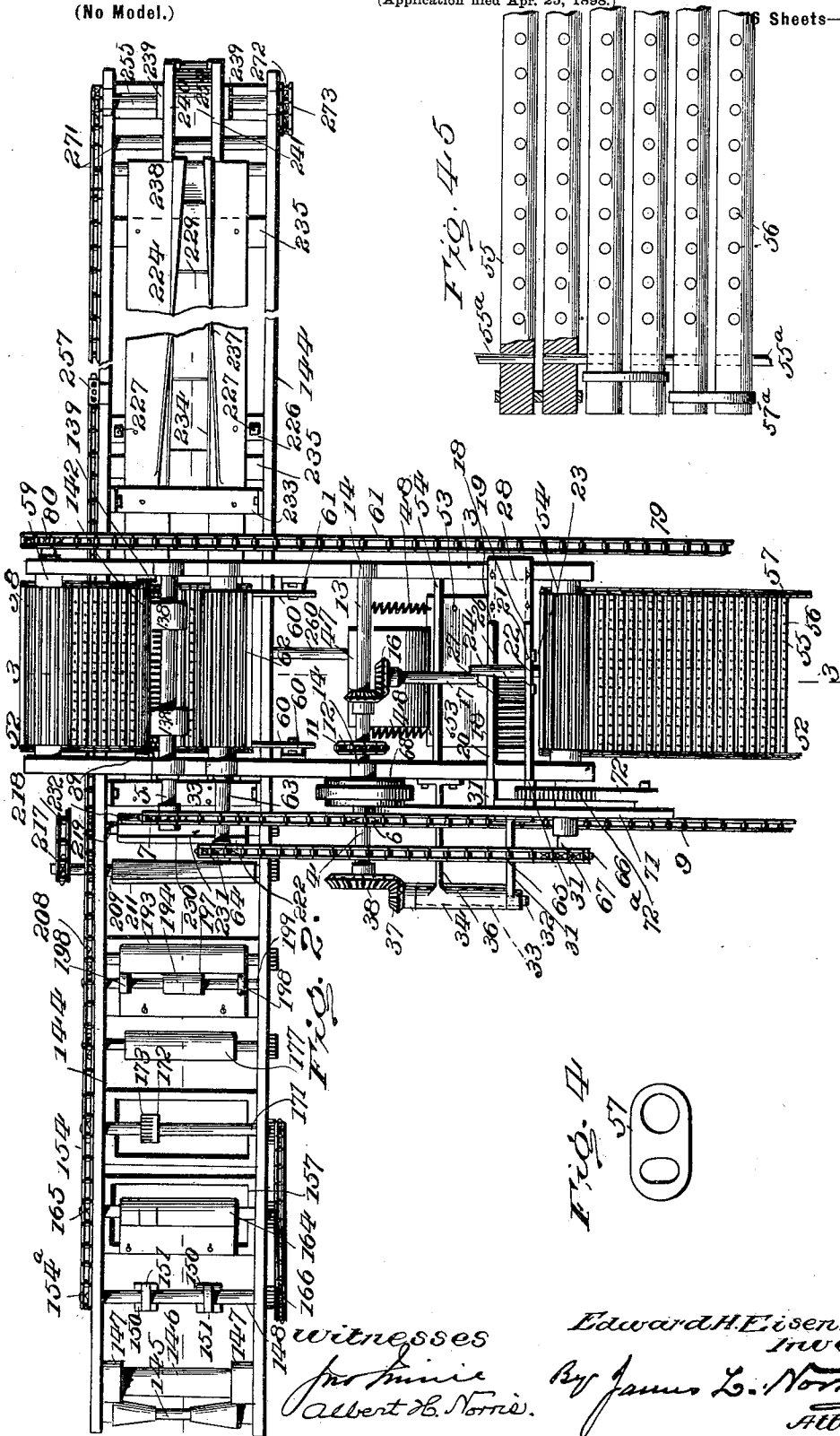

witnesses
for him
 Albert B. Norris.

Edward H. Eisenhart
 Inventor
 By James L. Norris
 Attorney

No. 643,047.

Patented Feb. 6, 1900.

E. H. EISENHART.

CONTINUOUS MATCH MAKING AND BOXING MACHINE.

(Application filed Apr. 25, 1898.)

(No Model.)

16 Sheets—Sheet 3.

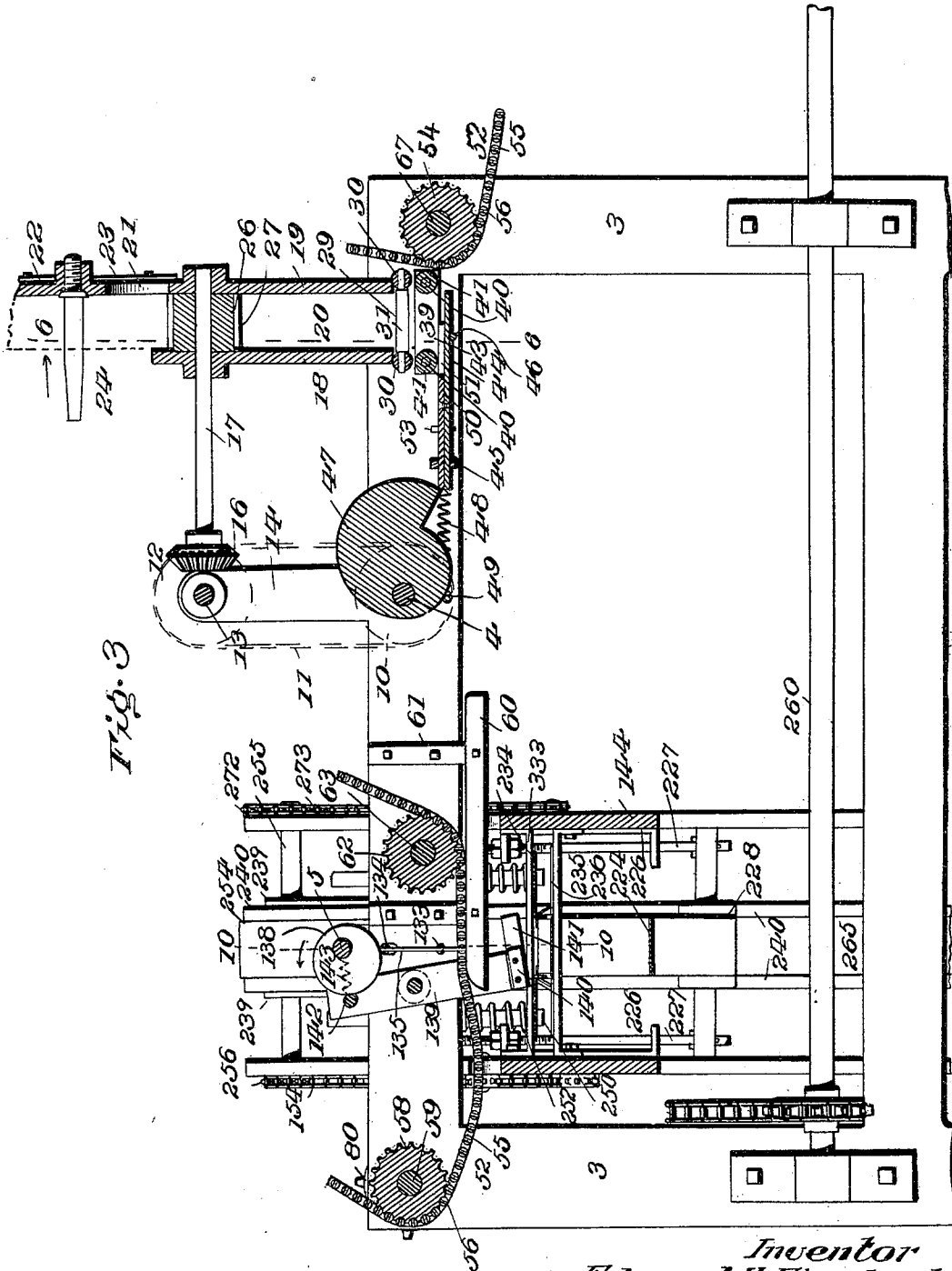

Fig. 3

Witnesses
for Invention
Albert D. Norris.

Inventor
Edward H. Eisenhart
By James L. Norris
Attorney

No. 643,047.

Patented Feb. 6, 1900.

E. H. EISENHART.

CONTINUOUS MATCH MAKING AND BOXING MACHINE.

(Application filed Apr. 25, 1898.)

(No Model.)

16 Sheets—Sheet 4.

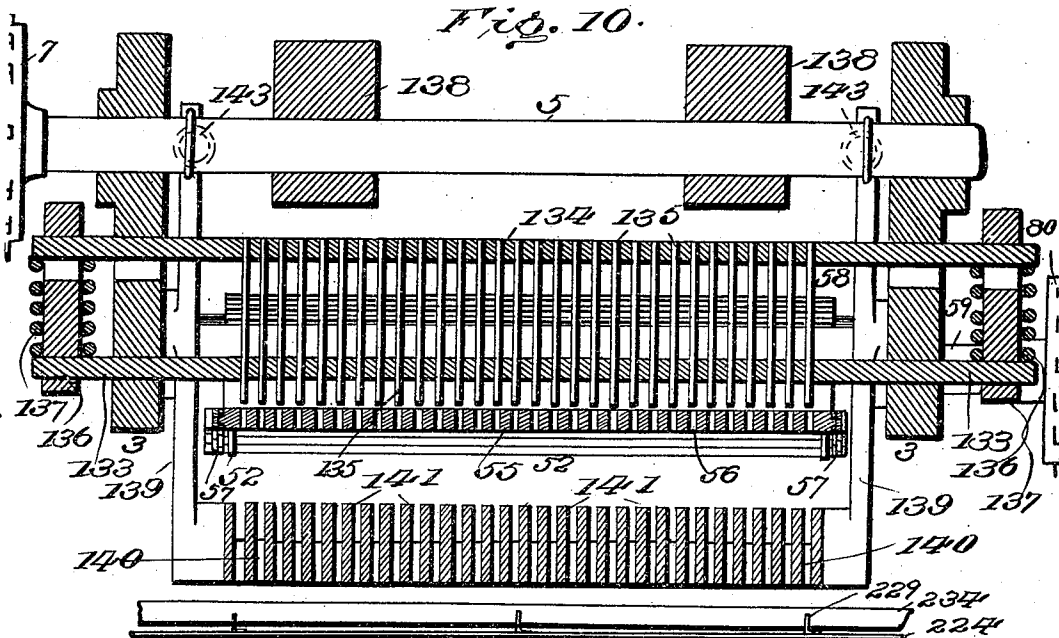
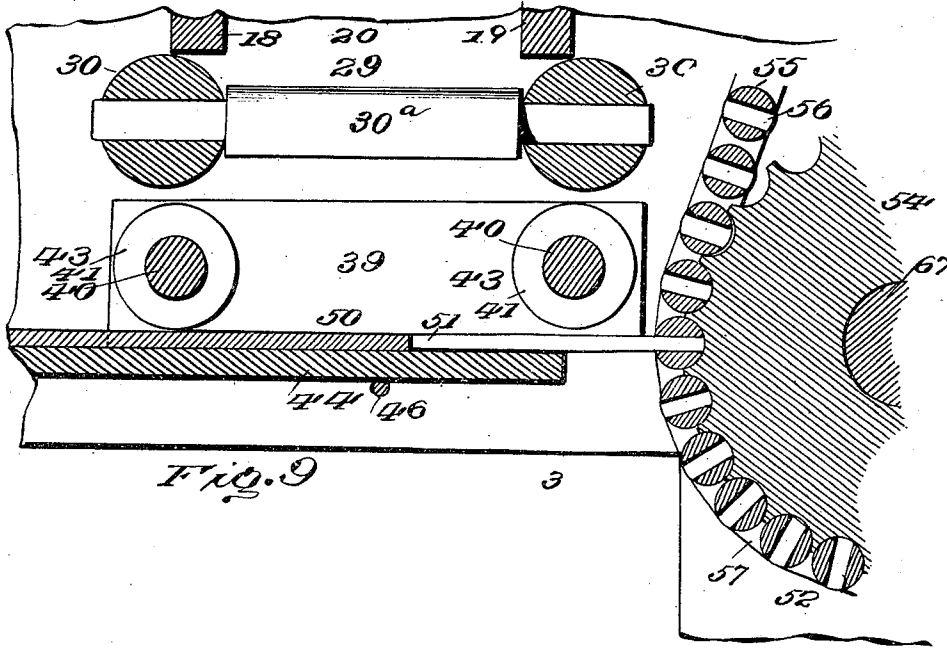

Fig. 5
Witnesses
for Invention
Albert B. Norris
52
57

E. H. Eisenhart
Inventor
By
James L. Norris
Attorney

No. 643,047.

Patented Feb. 6, 1900.

E. H. EISENHART.
CONTINUOUS MATCH MAKING AND BOXING MACHINE.

(Application filed Apr. 25, 1898.)

(No Model.)

16 Sheets—Sheet 5.

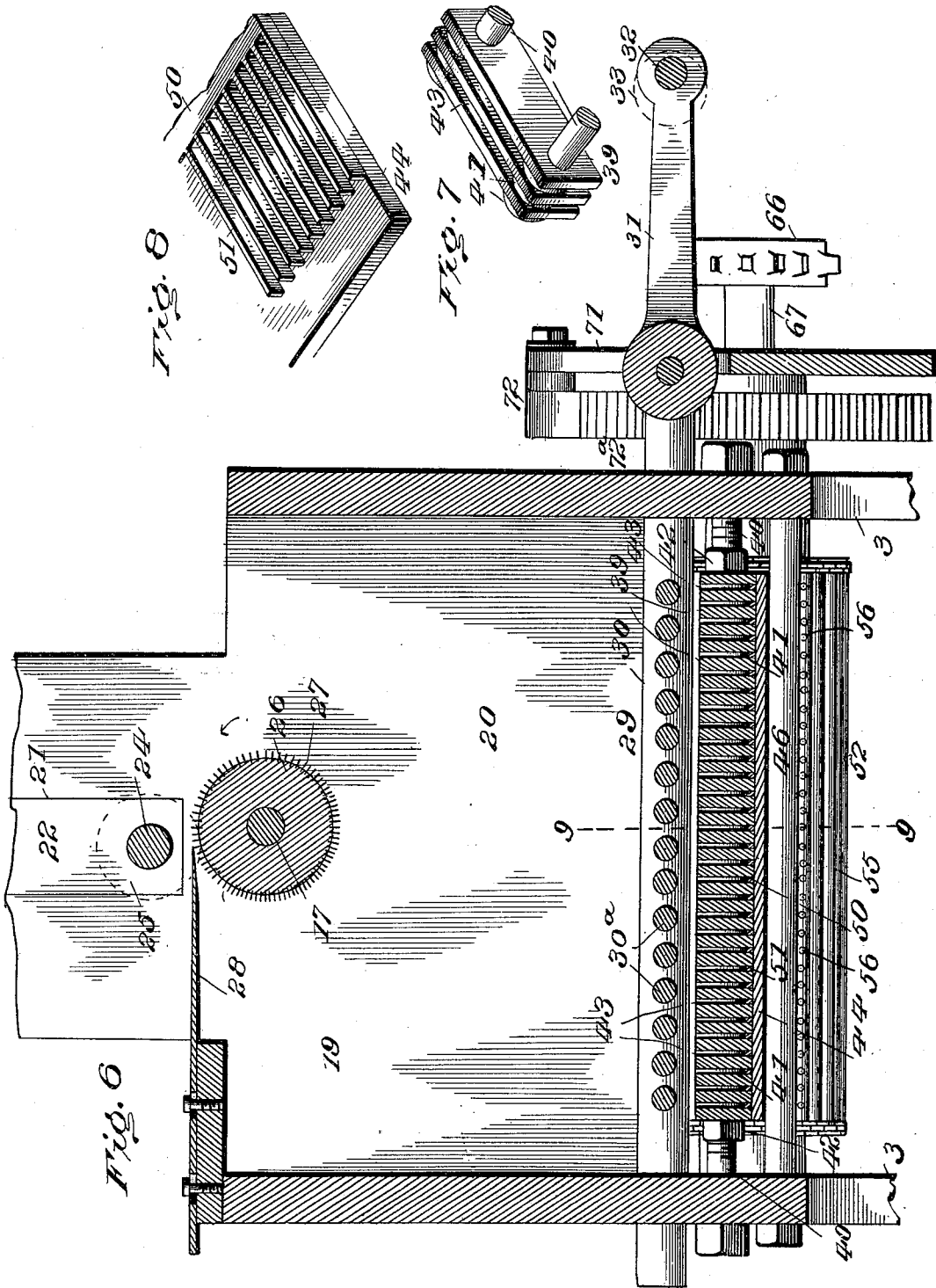

Witnesses
James L. Norris
Albert B. Norris.

Inventor *Edward H. Eisenhart*
by *James L. Norris*
Attorney

No. 643,047.

Patented Feb. 6, 1900.

E. H. EISENHART.
CONTINUOUS MATCH MAKING AND BOXING MACHINE.

(Application filed Apr. 25, 1898.)

(No Model.)

16 Sheets—Sheet 6.

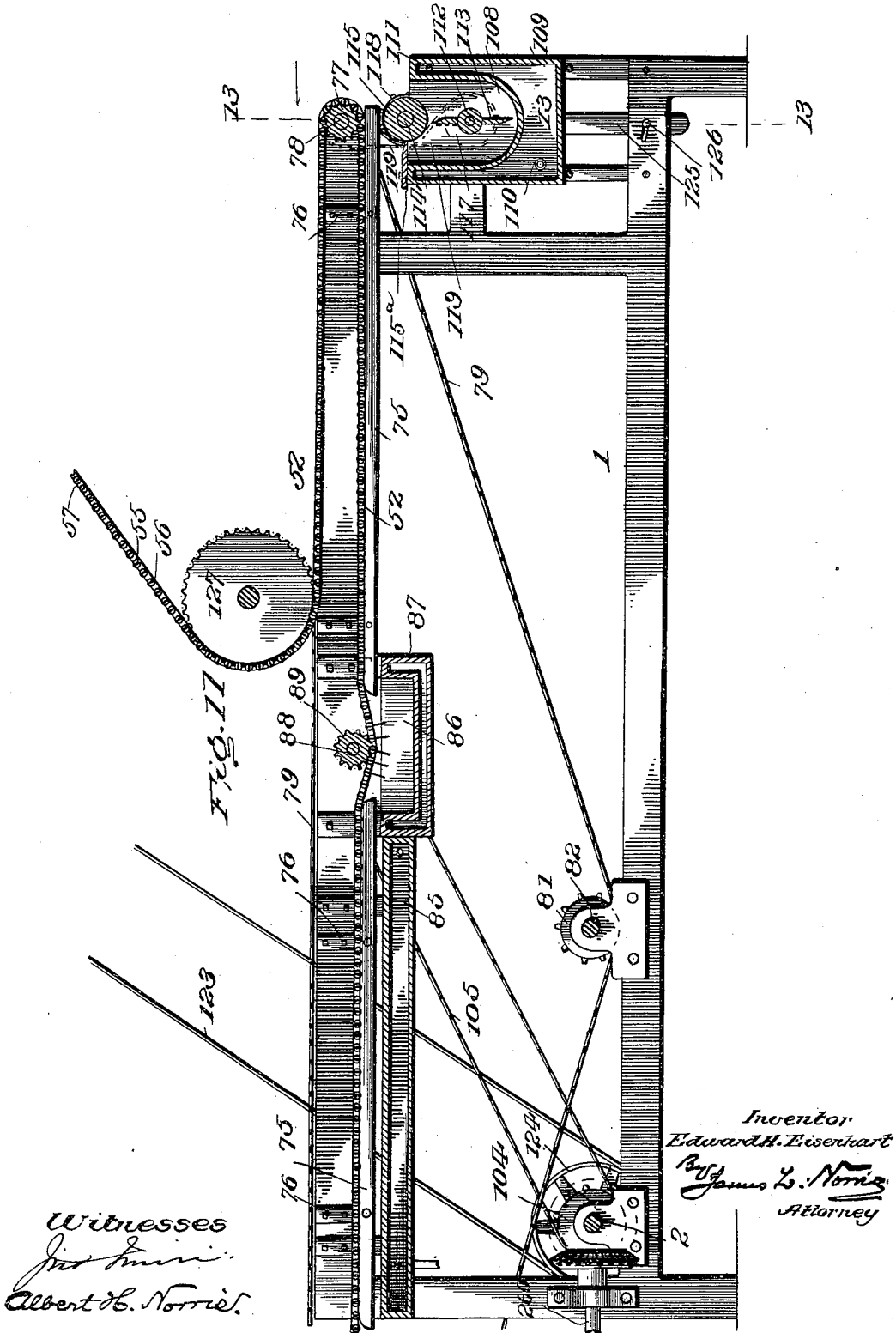

Witnesses
J. H. Smith
Albert H. Norris.

Inventor
Edward H. Eisenhart
By James L. Norris
Attorney

No. 643,047.

Patented Feb. 6, 1900.

E. H. EISENHART.

CONTINUOUS MATCH MAKING AND BOXING MACHINE.

(Application filed Apr. 25, 1898.)

(No Model.)

16 Sheets—Sheet 7.

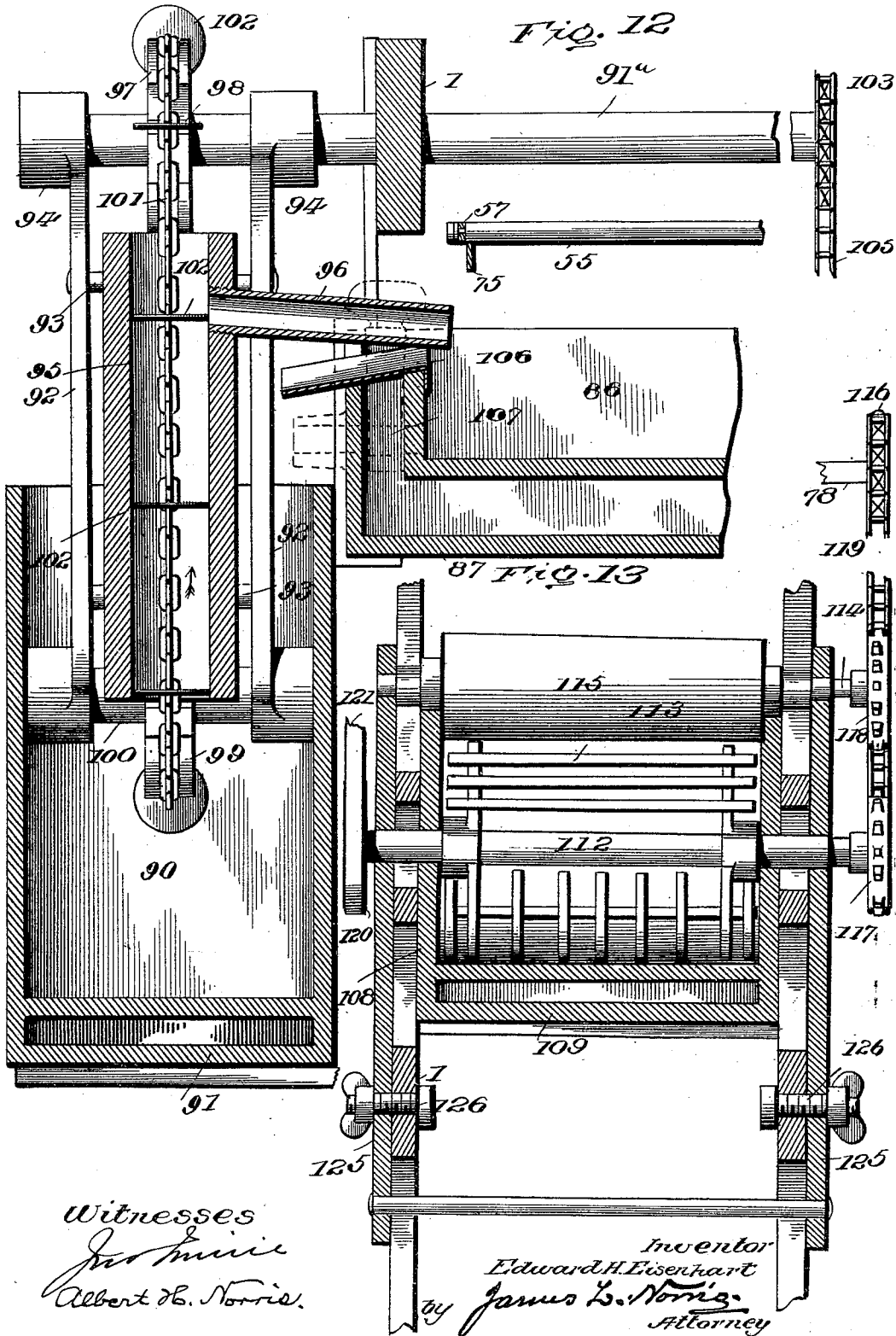

Witnesses
James L. Norris
Albert B. Norris.

Inventor
Edward H. Eisenhart
by *James L. Norris*
Attorney

No. 643,047.

Patented Feb. 6, 1900.

E. H. EISENHART.

CONTINUOUS MATCH MAKING AND BOXING MACHINE.

(Application filed Apr. 25, 1898.)

(No Model.)

16 Sheets—Sheet 8.

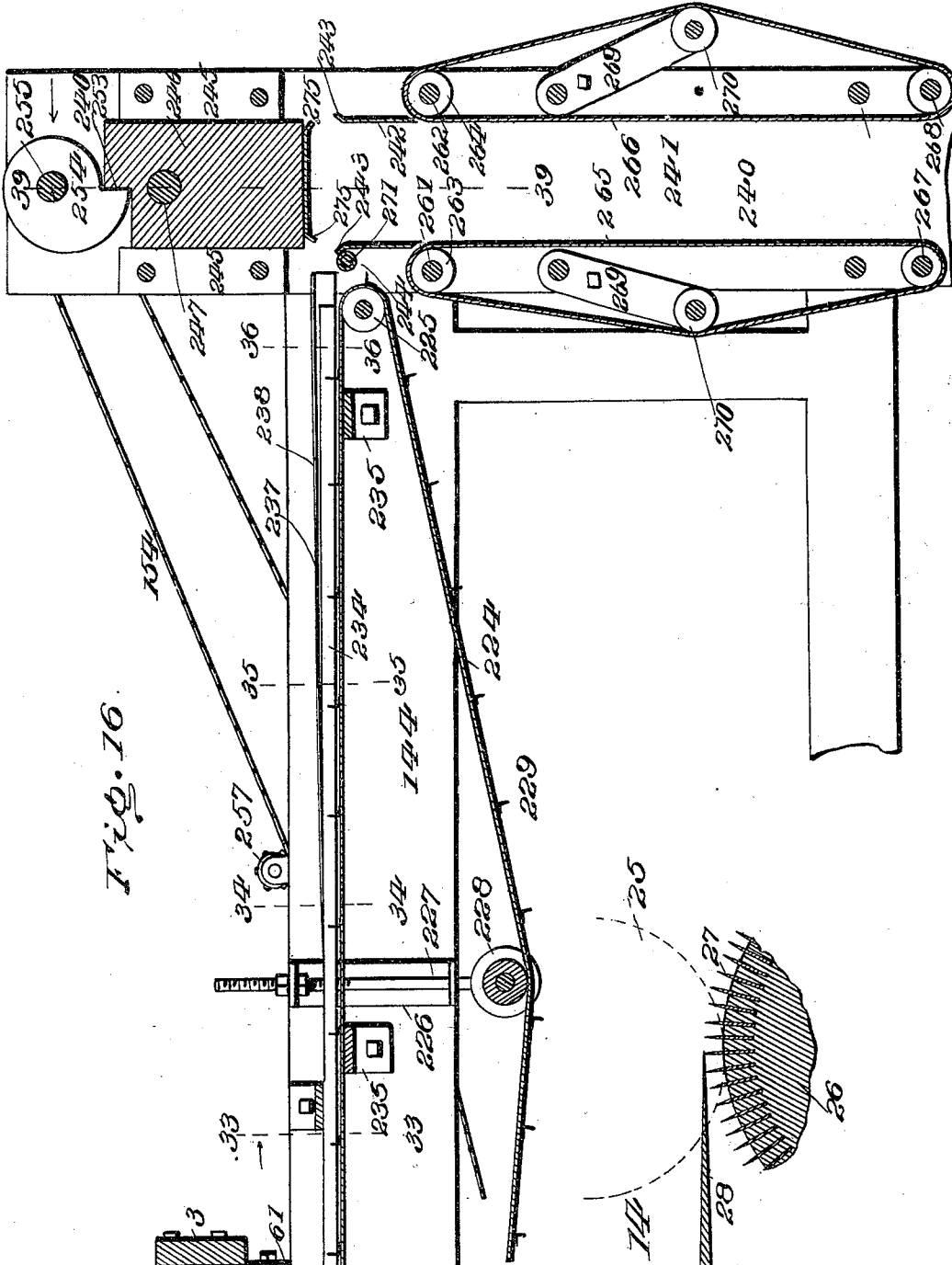

Fig. 16.

Fig. 17.

Witnesses
Johnnie
Albert B. Norris.

Inventor
Edward H. Eisenhart
 By *James L. Norris*
 Attorney

E. H. EISENHART.

CONTINUOUS MATCH MAKING AND BOXING MACHINE.

(Application filed Apr. 25, 1898.)

(No Model.)

16 Sheets—Sheet 9.

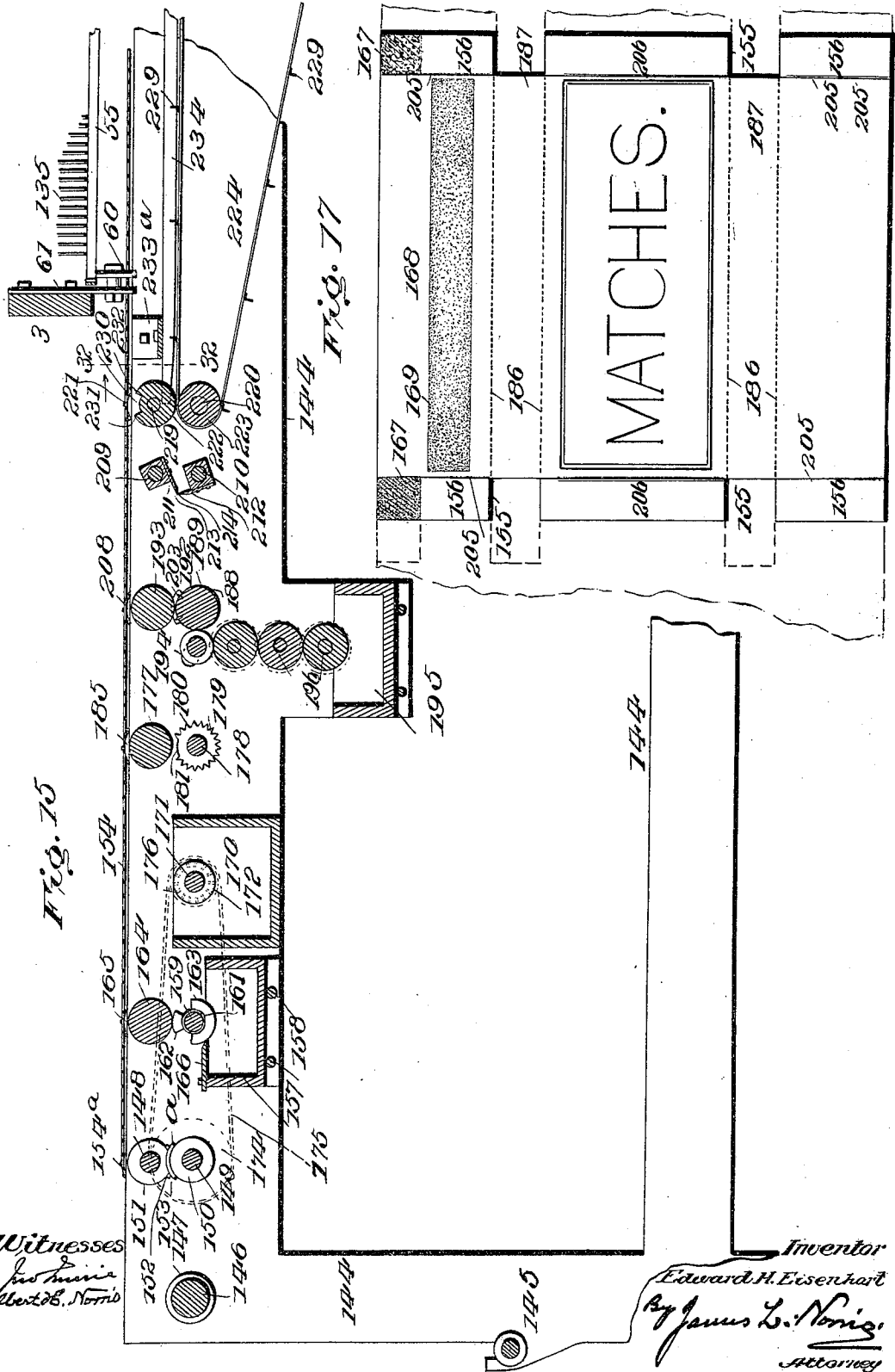

Witnesses
James L. Norris
Albert B. Norris

Inventor
Edward H. Eisenhart
 By *James L. Norris*
 Attorney

No. 643,047.

Patented Feb. 6, 1900.

E. H. EISENHART.

CONTINUOUS MATCH MAKING AND BOXING MACHINE.

(Application filed Apr. 25, 1898.)

(No Model.)

16 Sheets—Sheet 10.

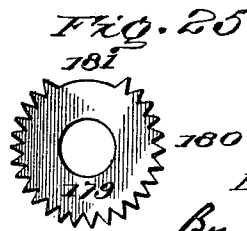
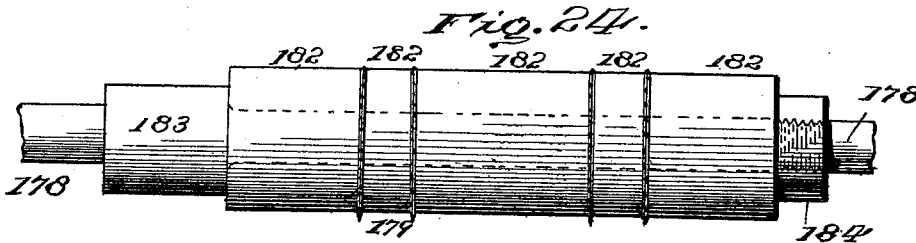
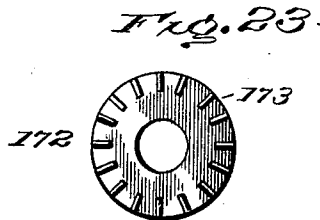
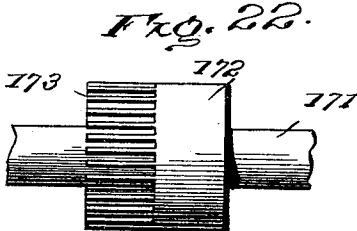
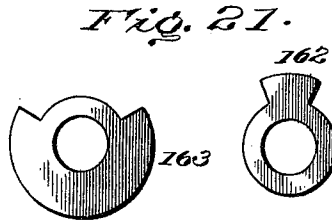
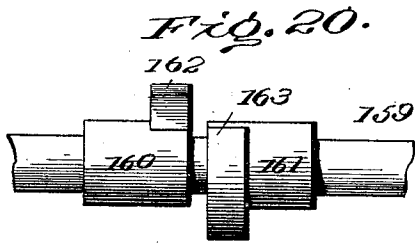
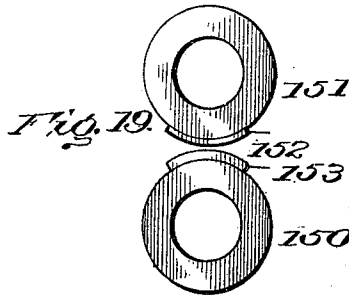
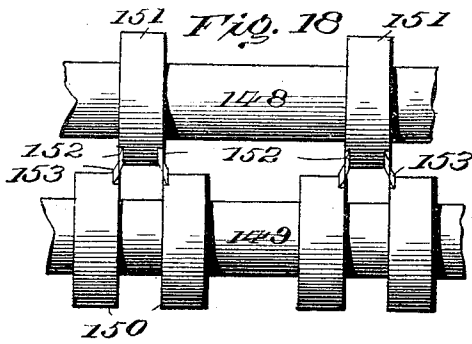

Witnesses
for Inventor
 Albert H. Norris.

Inventor
 Edward H. Eisenhart.
 By *James L. Norris*
 Attorney

No. 643,047.

Patented Feb. 6, 1900.

E. H. EISENHART.

CONTINUOUS MATCH MAKING AND BOXING MACHINE.

(Application filed Apr. 25, 1898.)

(No Model.)

16 Sheets—Sheet II.

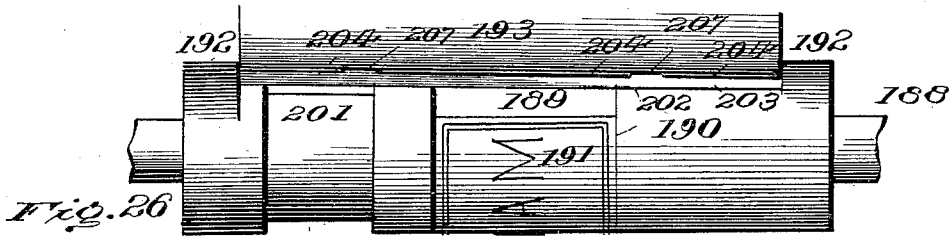

Fig. 26

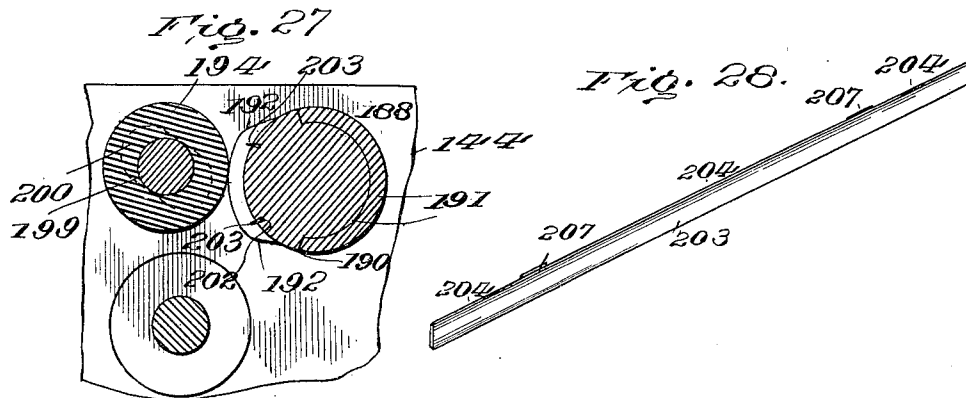

Fig. 27

Fig. 28

Fig. 29

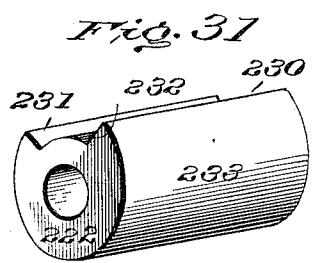
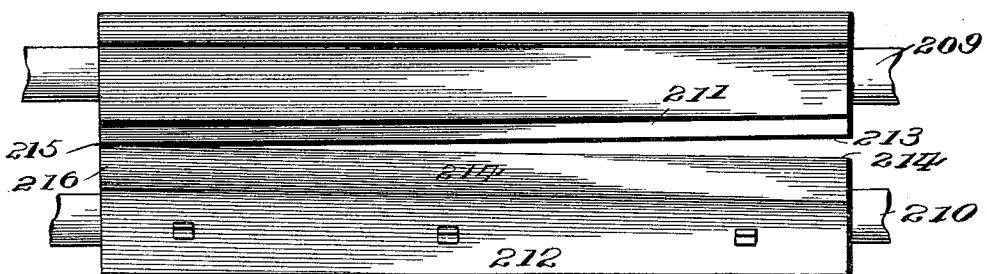

Fig. 31

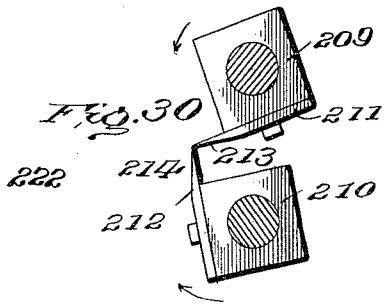

Fig. 30

Witnesses
Geo. Smith
Albert W. Norris

Inventor
Edward H. Eisenhart
By James L. Norris
 Attorney

No. 643,047.

Patented Feb. 6, 1900.

E. H. EISENHART.

CONTINUOUS MATCH MAKING AND BOXING MACHINE.

(No Model.)

(Application filed Apr. 25, 1898.)

16 Sheets—Sheet 12.

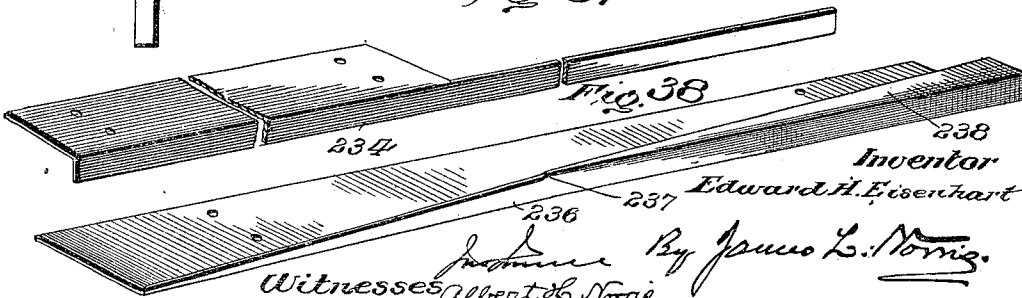
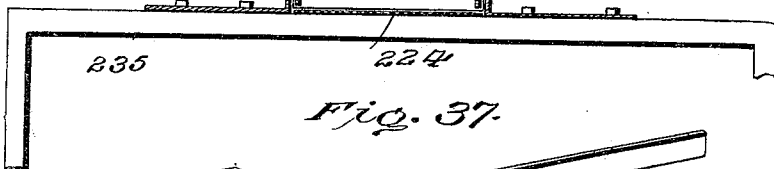
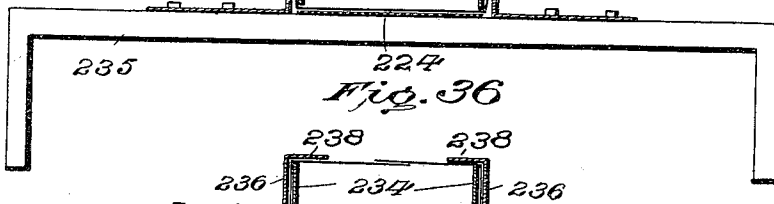
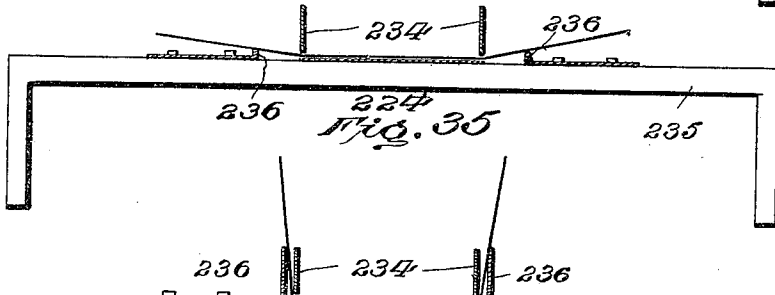
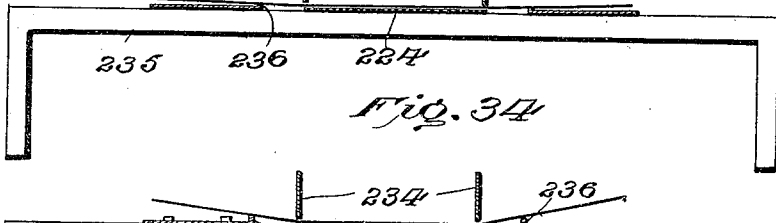
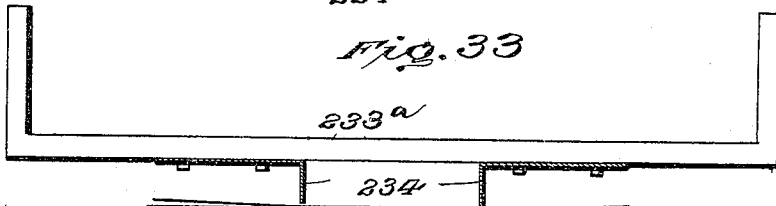
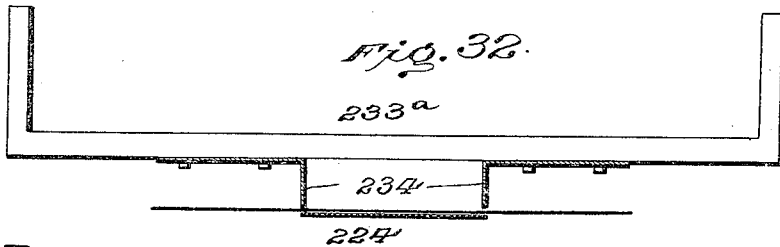

Inventor
Edward H. Eisenhart
By James L. Norris
Attorney
Witnesses Albert D. Norris.

No. 643,047.

Patented Feb. 6, 1900.

E. H. EISENHART.

CONTINUOUS MATCH MAKING AND BOXING MACHINE.

(Application filed Apr. 25, 1899.)

(No Model.)

16 Sheets—Sheet 13.

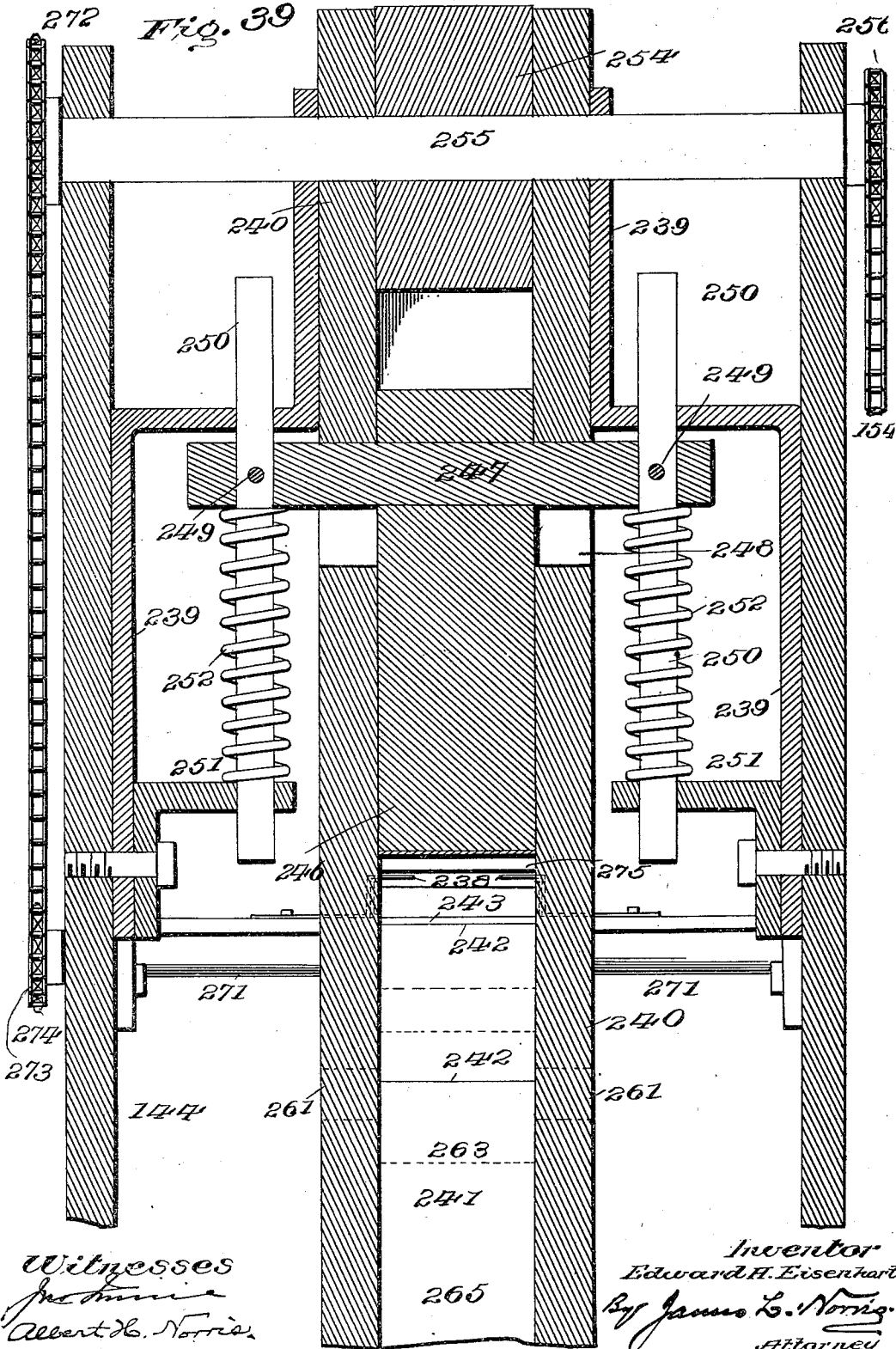

E. H. EISENHART.

CONTINUOUS MATCH MAKING AND BOXING MACHINE.

(Application filed Apr. 25, 1898.)

(No Model.)

16 Sheets—Sheet 14.

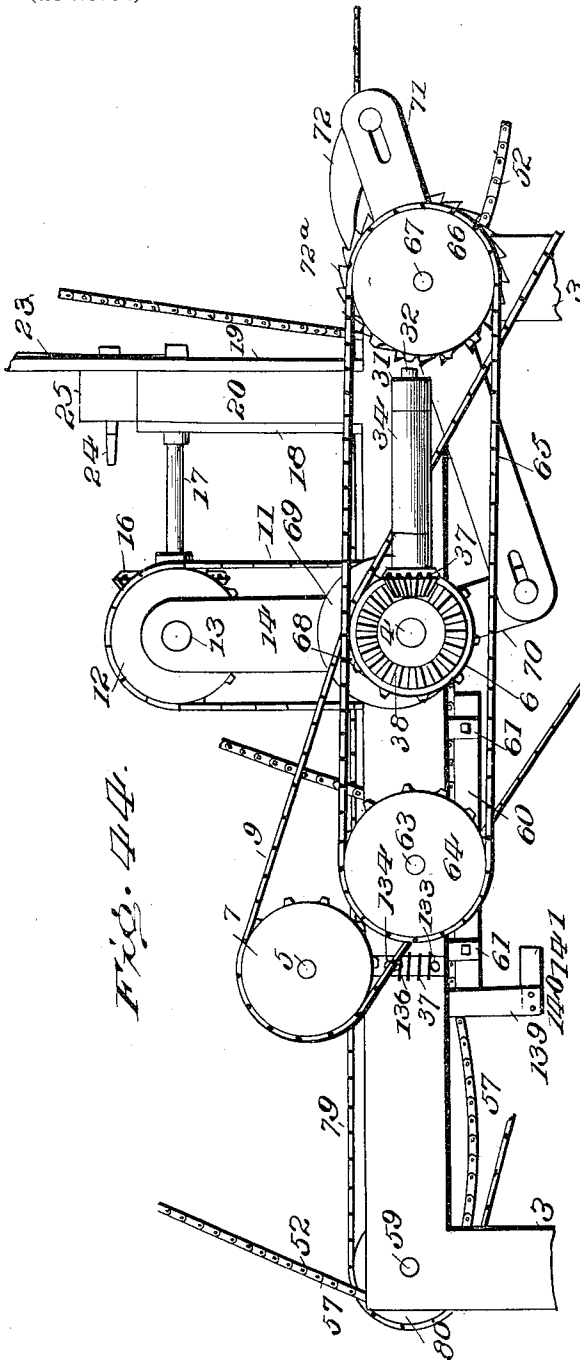

Fig. 42.

Fig. 43.

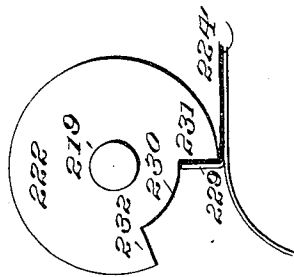

Fig. 43.

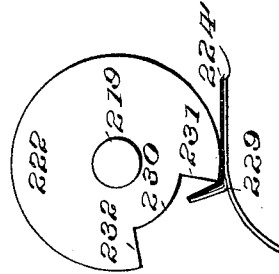

Fig. 41.

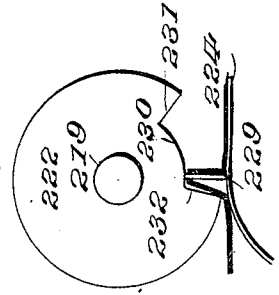
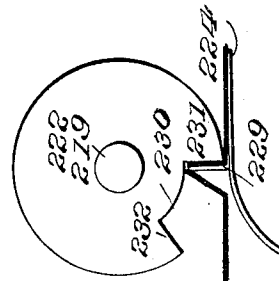

Fig. 40.



Witnesses

For witness
Robert B. Norris.

Inventor

Edward H. Eisenhart

By *James L. Norris*
Attorney

No. 643,047.

Patented Feb. 6, 1900.

E. H. EISENHART.

CONTINUOUS MATCH MAKING AND BOXING MACHINE.

(Application filed Apr. 25, 1898.)

(No Model.)

16 Sheets—Sheet 15.

FIG. 146.

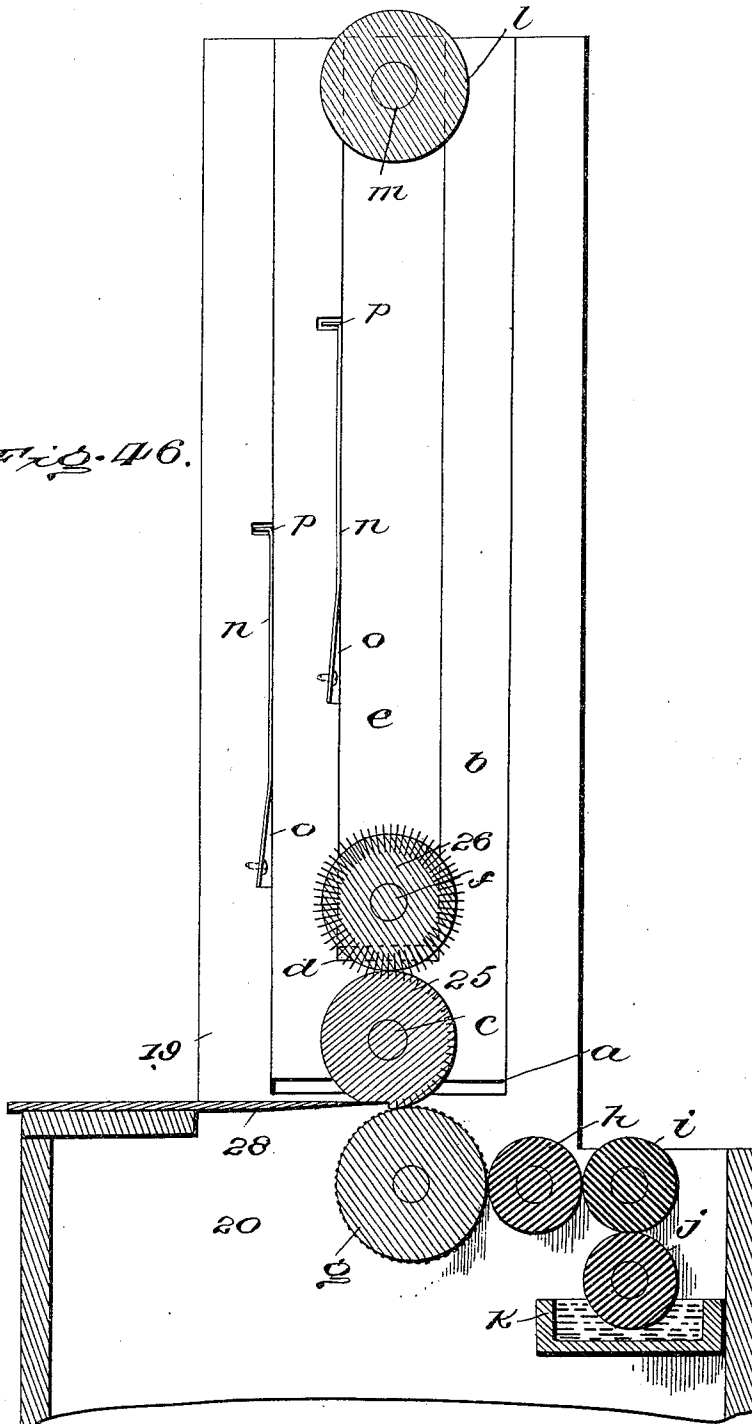

Inventor

Witnesses

John L. Moore
Albert H. Norris

By

Edward H. Eisenhart
James L. Norris
 Attorney

No. 643,047.

Patented Feb. 6, 1900.

E. H. EISENHART.

CONTINUOUS MATCH MAKING AND BOXING MACHINE.

(Application filed Apr. 25, 1898.)

(No Model.)

16 Sheets—Sheet 16.

FIG. 47.

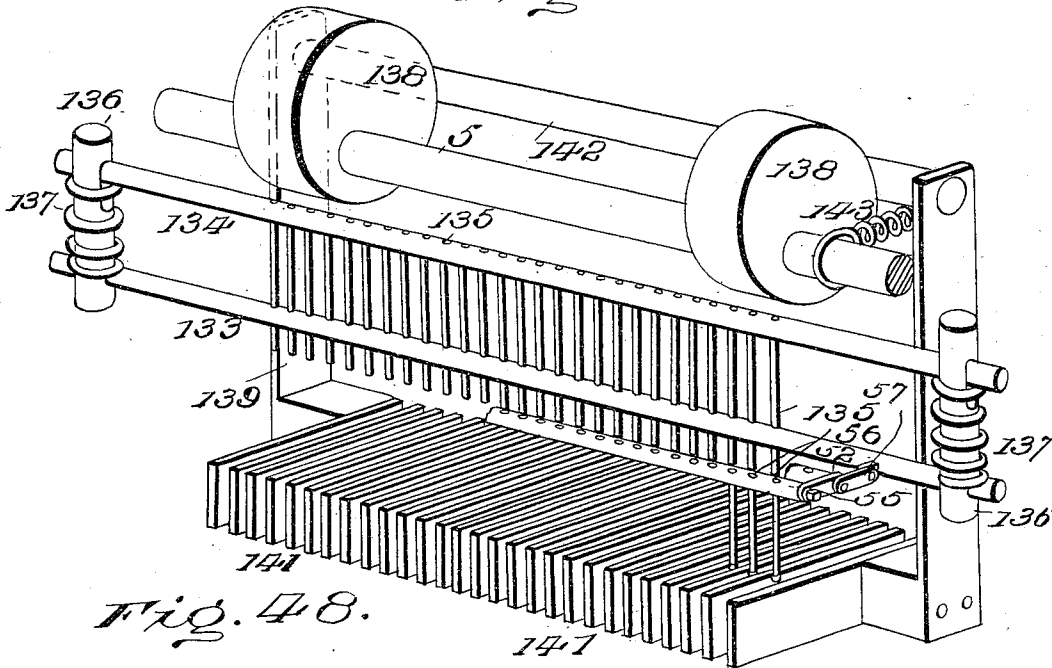

FIG. 48.

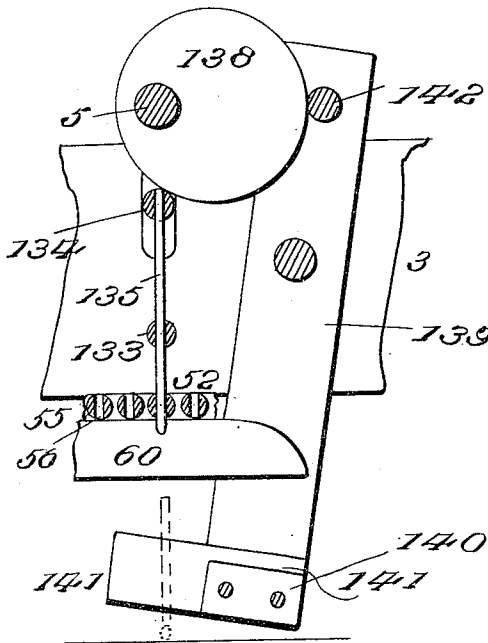
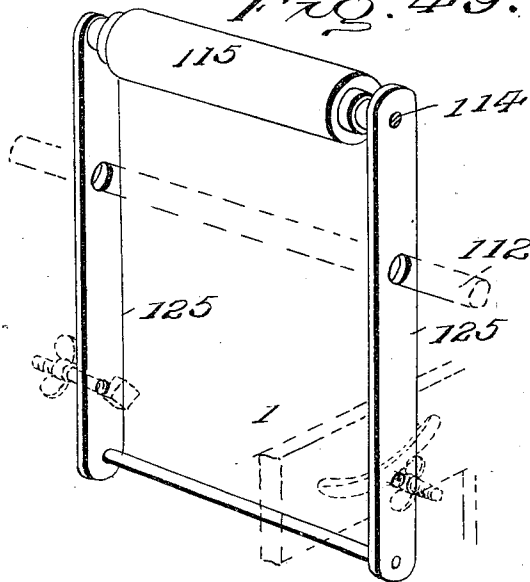

FIG. 49.



Witnesses
J. M. Smith
V. Coombs

Inventor
Edward H. Eisenhart
 by *James L. Norris*
 Att. Attorney

UNITED STATES PATENT OFFICE.

EDWARD H. EISENHART, OF NEW YORK, N. Y., ASSIGNOR OF ONE-HALF TO
G. M. TUSTIN, TRUSTEE, OF BLOOMSBURG, PENNSYLVANIA.

CONTINUOUS MATCH MAKING AND BOXING MACHINE.

SPECIFICATION forming part of Letters Patent No. 643,047, dated February 6, 1900.

Application filed April 25, 1898. Serial No. 678,819. (No model.)

To all whom it may concern:

Be it known that I, EDWARD H. EISENHART, a citizen of the United States, residing at New York, in the county of New York and State
5 of New York, have invented new and useful Improvements in Continuous Match Making and Boxing Machines, of which the following is a specification.

This invention relates to a continuous
10 match making and boxing machine, and has for its object to provide a machine wherein a previously-prepared log or cylinder of wood is reduced to splints, the splints treated to produce finished matches, and the matches
15 packed in boxes and the boxes closed in readiness to be placed upon the market, the operation being a continuous one and automatic throughout.

To this end my invention consists in the
20 combination, with a match-making machine, of box making and packing mechanism for packing the matches in boxes, the combined operation of making the matches and boxing them being continuous. It also consists in
25 other combinations and in certain features of construction and the arrangement of parts, all of which will be hereinafter described.

In the operation of the machine the match-splints are cut from the prepared cylinder of
30 wood and are fed by suitable mechanism to an endless carrier provided with perforated carrier-bars and are inserted end first in the perforations in said carrier-bars and held therein. The endless carrier carries the
35 splints over a heater, which operates to open the pores of the wood, and from thence over a tank containing melted paraffin, into which the splints are dipped. From the dipping-tank the splints are conveyed over a roller
40 revolving in a tank containing the igniting composition and which operates to apply the composition to the free ends of the splints to form the heads. From the composition-roller the carrier takes the splints through a cooling-room, in which the igniting composition is set,
45 and from said room carries them to the ejecting and boxing mechanism, where the finished matches are ejected and deposited in a regular manner in boxes and the boxes closed
50 up and discharged from the machine ready for the market.

In order that those skilled in the art may make and use my invention, I will now describe the same fully, reference being had to the accompanying drawings, forming a part
55 of this specification, wherein—

Figure 1 is a side elevation of the match-making machine, showing the box-machine in end elevation. Fig. 2 is a top plan view of a part thereof. Fig. 3 is a vertical sectional
60 view taken on the line 3 3 of Fig. 2. Fig. 4 is a detail view of one of the links of the endless carrier. Fig. 5 is a detail plan view of a part of the endless carrier. Fig. 6 is a vertical sectional view on the line 6 6 of Fig. 3
65 looking in the direction of the arrow. Fig. 7 is a detail perspective view of a portion of the splint-feeding mechanism. Fig. 8 is a similar view of a part of the splint-inserting mechanism. Fig. 9 is a sectional view of the
70 splint feeding and inserting mechanism, taken on the line 9 9 of Fig. 6. Fig. 10 is a vertical sectional view of the match-ejecting mechanism, taken on the line 10 10 of Fig. 3. Fig.
75 11 is a vertical longitudinal sectional view taken through the frame 1 and illustrating the heater and the means for applying the paraffin and igniting composition to the splints. Fig. 12 is a vertical sectional view of the paraffin-applying mechanism, taken on the line
80 12 12 of Fig. 1. Fig. 13 is a similar view of the composition-tank, taken on the line 13 13 of Fig. 11. Fig. 14 is a detail sectional view of the splint-cutting mechanism. Fig. 15 is a vertical longitudinal sectional view of one
85 part of the box-making machine. Fig. 16 is a similar view of the other part thereof. Fig. 17 is a bottom plan view of one of the box-blanks. Fig. 18 is a view in elevation illustrating the web-slitting rolls. Fig. 19 is a side
90 elevation of two of said rolls detached. Fig. 20 is a view similar to Fig. 18, illustrating the gluing-rolls. Fig. 21 is a detail view of the gluing-rolls removed. Fig. 22 is a view in elevation of the sand-roller. Fig. 23 is an end
95 view thereof. Fig. 24 is a detail view of the web-serrating roll. Fig. 25 is a detail view of one of the serrating-disks removed. Fig. 26 is a detail view of the printing-cylinder. Fig. 27 is a transverse sectional view of the printing-cylinder and illustrating two of the inking-rollers. Fig. 28 is a detail perspective
100

view of one of the scoring and cutting blades removed from the printing-cylinder. Fig. 29 is a view in elevation of the shearing-knives. Fig. 30 is a transverse sectional view thereof.

5 Fig. 31 is a detail perspective view of the apron-feed and end-flap-folding roll. Fig. 32 is a transverse sectional view of the side-flap-folding mechanism, taken on the line 32 32 of Fig. 15. Figs. 33, 34, 35, and 36 are similar

10 views, respectively, taken on the lines 33 33, 34 34, 35 35, and 36 36 of Fig. 16. Fig. 37 is a detail perspective view of one of the formers against which the side flaps of the box are folded. Fig. 38 is a similar view of one

15 of the folders which fold the side flaps up against and over the formers. Fig. 39 is a sectional view taken on the line 39 39 of Fig. 16. Figs. 40, 41, 42, and 43 are detail views of the folding-rolls, showing their positions at different stages of the folding operation. Fig.

20 44 is an enlarged detail view of some of the parts shown in Fig. 1. Fig. 45 is a detail view illustrating a modified form of splint-carrier. Fig. 46 is a similar view of a modified

25 form of splint-cutting mechanism and means for printing the match-splints. Fig. 47 is a detail perspective view of the match ejecting and depositing mechanism. Fig. 48 is a partial detail sectional view of the same mechanism. Fig. 49 is a detail view showing the

30 means for adjusting the composition-roller that operates to apply the igniting composition to the ends of the match-splints.

Referring to the drawings, the numeral 1 indicates a frame of any suitable or preferred construction, in the lower portion of which is journaled the main or driving shaft 2, and arranged in front of the forward end of the frame

35 1 is a frame 3, in the upper sides of which are journaled shafts 4 and 5, on which are respectively fixed sprocket-wheels 6 and 7. A sprocket-wheel 8 is fixed on the driving-shaft 2, and about said sprocket-wheels 6, 7, and 8

40 4 is fixed a sprocket-chain 9. On the shaft 4 is fixed a sprocket-wheel 10, which is geared by a chain 11 with a sprocket-wheel 12, fixed on a shaft 13, journaled in arms 14, extending upward from the sides of the frame 3.

45 On the shaft 13 is fixed a beveled gear 15, which meshes with a similar gear 16 on one end of a shaft 17, the other end of which is journaled in the front and rear walls 18 and 19 of the splint-hopper 20. In the rear and upwardly-extended wall 19 of the hopper 20

50 is formed a dovetailed slot or way 21, (see Figs. 1 and 3,) in which is adapted to freely move in a vertical direction a slide 22, which is held to its seat in the way 21 by battens 23, attached to the wall 19 and overlapping the edges of the slide. Fixed in the slide is a spindle 24, which carries the wooden cylinder, from which the splints are to be cut. The cylinders are sawed from ordinary saw-mill-logs, the log being sawed into sections

55 transversely to the grain and each section being equal in length to the length of the match-splints. The sections are turned to form true

cylinders and are bored centrally lengthwise of the grain to fit over the spindle 24. When one of the cylinders 25 is journaled on the spindle so as to rotate loosely thereon, its periphery lies between the walls 18 and 19 of the hopper and rests upon the rotary scorer 26. The scorer consists of a cylinder having a plurality of longitudinal grooves formed in its periphery, in which are fitted knives 27.

70 The scoring-cylinder is fixed on the shaft 17 between the walls 18 and 19 of the hopper 20. Adjustably attached to the upper portion of the walls of the hopper is a bed upon which rests a horizontal cutter 28, the cutting edge of which intercepts the circular plane described by the cutting edges of the scoring-knives 27. The shaft 4 is rotated by the driving-chain 9, and by means of the chain 11 and bevel-gears 15 16 rotates the shaft 17 and the scorer 26. Inasmuch as the slide 22 is fitted to slide freely in its way in the hopper-wall 19 the cylindrical stock 25, owing to its weight and the weight of the slide, is fed to the scoring-knives 27, and as the latter are revolved they cut or score longitudinal grooves or incisions in the periphery of the cylindrical stock. The scoring-knives are arranged on the cylinder 26 at such distances apart and they project from the periphery of the cylinder at such distance that the grooves or incisions cut in the periphery of the cylindrical stock 25 are equal in depth and distance apart to the width of the match-splints. The scorer

80 in its rotation causes the cylindrical stock to rotate with it and successively and continuously cuts the grooves or incisions. As the stock rotates the cutting-blade 28 operates to plane off the grooved or scored face or periphery of the stock, thus completing the formation of the splints and severing them from the stock. As the cylindrical stock is fed down a fresh or unscored portion of the stock is constantly presented to the scoring-knives.

85 As most clearly shown in Fig. 6 of the drawings, the center of the scoring-cylinder is disposed to one side of the axial center of the spindle 24, whereby the knives 27 complete their cuts before the blade 28 operates to slice off the splints. This arrangement is of importance, for should the scoring-cylinder be journaled directly beneath the spindle the blade 28 would become inoperative when the cylindrical piece of wood became reduced to a small diameter. From the scorer the splints drop down in the hopper onto a separator 29, arranged to reciprocate in the bottom of the hopper. The separator 29 consists of a rectangular frame, in the sides of which are fixed the opposite ends of bars 30.

90 To the frame of the separator is pivotally connected one end of a connecting-rod 31, the opposite end of which is journaled on a wrist-pin 32, (see Figs. 2 and 6,) formed on one end of a shaft 33. The shaft 33 is journaled in a sleeve 34, attached by a bracket 36 to one side of the frame 3, and has fixed on its end a beveled gear 37, that meshes with

a similar gear 38, fixed on the end of the shaft 4. By these means the separator is given a reciprocating movement in the bottom of the hopper, and as the splints drop onto the bars 30^a the latter cause them to spread out lengthwise and parallel with each other over and agitate them down between the bars into the feeder arranged beneath the separator. The feeder comprises a number of rectangular plates 39, (most clearly shown in Figs. 6 and 7,) which are arranged edgewise and parallel to one another on two rods 40, that are fixed at their ends to frame 3. The plates 39 are held separated at the proper distance apart—that is to say, at a distance approximately equal to the width of a match-splint—by distance disks or washers 41 and are fixed in position by nuts 42, threaded upon the rods 40 and abutting the end plates. As shown in Figs. 3 and 6, the plates 39 are arranged parallel to and beneath the bars 30^a of the separator, and as the splints are agitated by the latter they fall into the openings or apertures 43 between the plates and onto a table 44, reciprocating immediately beneath the bottom of the feeder. The table 44 consists of a flat plate arranged to slide in a slotted cross-bar 45, (see Fig. 3,) fixed to the sides of the frame 3, and rests at its forward end on a rod 46, also fixed in said frame. The rear end of the plate is engaged by the periphery of a cam 47, fixed on the shaft 4, which during a part of its revolution operates to thrust the plate forward. The plate or table is retracted by two coiled springs 48, which at their forward ends are attached to the table and at their rear ends are attached to a cross-bar 49, fixed in the sides of the frame 3. Secured to the upper side of the table 44 is a comb-plate 50, provided with a series of teeth 51, as best shown in Fig. 8. The teeth extend longitudinally on the table and are somewhat shorter than the match-splints and are formed at such distances apart and at such height as to permit a single splint only to lie on the table between each two adjacent teeth. As the table recedes beneath the feeder the splints drop horizontally through the apertures 43 in the feeder onto the table and between the teeth 51, and as the table is thrust forward by the cam the ends of the splints are inserted in an endless carrier 52, presently to be described. Pins 53 are carried by the table 44 and are adapted to abut the cross-bar 45 and limit the receding movement of the table as it is withdrawn by the springs 48. Journalled in the sides of the frame 3 immediately in rear of the splint-feeding mechanism is a shaft 67, on which is fixed a sprocket-roller 54, about which the endless carrier 52 travels. Said carrier also travels about other sprocket rollers or wheels hereinafter referred to, and consists of two endless chains carrying transverse bars 55, which are each provided with a series of perforations 56, each perforation being of a size just sufficient to receive the end of a splint. In practice the perforations

will be countersunk or flared at their opposite ends, as is usual, to permit of the easy entrance of the splints and the ejecting push-rods 135, hereinafter described. The carrier-bars 55 are reduced at their opposite ends, (see Fig. 5,) one end of each of said bars being round and the other end square in cross-section, and the bars are so arranged that the round ends of the bars alternate with the square ends—that is to say, the bars are so arranged that the square end of each bar on one side of the carrier will be between the round ends of the two adjacent bars, and therefore the opposite round end of the bar at the other side of the carrier will be between the square ends of the adjacent bars. Each of the carrier-bars is journalled at its opposite ends in links 57, (see Fig. 4,) each link having a round and an approximately rectangular or elongated bearing for the reception of the correspondingly-shaped journals of the carrier-bars. The links on one side of the carrier will of course be arranged reversely to the links on the other side and will be arranged over the reduced ends of the carrier-bars in the manner most clearly shown in Fig. 5, forming practically endless chains and carrying the bars 55 in such manner that while they are prevented from having any rotary movement about their own axes they may travel in the arc of a circle in passing around or about the sprocket wheels and rollers. The splints inserted in the perforations in the carrier-bars will thus be held at all times at right angles to the carrier.

In Fig. 45 I have illustrated a modified form of carrier wherein the carrier-bars 55 are fastened together in pairs by pins 55^a, which pass transversely between the bars at right angles to the perforations 56. The links 57^a are provided at opposite ends with round bearings, in which are journalled the rounded ends of the carrier-bars, the construction being such that the carrier is free to pass easily about the different sprocket wheels and rollers; but the carrier-bars of each pair can have no movement independently of one another.

The endless carrier 52 passes about a sprocket-roller 58, fixed on a shaft 59, journalled in the front of the frame 3 and driven in the manner hereinafter described. From the sprocket-roller 58 the carrier passes over guides 60, attached by brackets 61 to the sides of the frame 3, and under and about a sprocket-roller 62, fixed on a shaft 63, journalled in the sides of the frame 3. On the end of the shaft 63 is fixed a sprocket-wheel 64, which is geared by sprocket-chain 65 to a sprocket-wheel 66, fixed on the end of the shaft 67, before referred to. On the shaft 4 is fixed an eccentric 68, on which latter is journalled a collar 69, provided with a downwardly-extending arm 70, which is pivotally connected at its lower end to one end of a rocking lever 71. The rocking lever near its other end is loosely fulcrumed on the end of

the shaft 67, and pivoted in said end of the rocking lever is a pawl 72, which engages a ratchet-wheel 72^a, fixed on the shaft 67. The shaft 4 is rotated by the drive-chain 9, as before described, and rotates the eccentric 68, which by means of the collar 69 and arm 70 communicates a rocking motion to the lever 71, and thus causes the pawl to impart a step-by-step rotary movement to the sprocket-roller 54 and carrier 52. In this manner the carrier-bars 55 are successively brought opposite the splint-feeder. The endless carrier after leaving the sprocket-roller 62 is carried up and over a sprocket-roller 73, journaled in an overhead support 74, and is thence carried down and about the roller 54, and from the latter it is carried over onto the frame 1, as hereinafter described. Between the rollers 58 and 62 and between the roller 54 and frame 1 the endless carrier is slack and sags down, while at all other points it is taut. This is to compensate for the temporary stoppage of the carrier at the points where the splints are inserted and ejected from the carrier. As one of the carrier-bars is brought to a state of rest in line with the splint-feeder the table 44 is thrust forward by the cam 47 and forces the ends of the splints into the perforations 56 in the bar, where they are firmly held. The cam 47 and eccentric 68 are so formed and the parts operated thereby are so timed that the sprocket-roller 54 will remain temporarily at a state of rest after it has brought one of the carrier-bars opposite the table 44 and while the latter is advancing, and it will then be given a partial rotation to bring another carrier-bar into position while the table is receding. As the movement of the carrier is uninterrupted after leaving the roller 54 until it arrives opposite the ejecting mechanism, it is necessary to have the carrier slack at the points mentioned to compensate for the step-by-step movement at the points named.

The carrier 52 passes over guides 75, fixed by brackets 76 to the upper part of the frame 1, and about a sprocket-roller 77, fixed on a shaft 78, journaled in the rear end of said frame. A sprocket-wheel is fixed on one end of the shaft 78, and a sprocket-chain 79 passes about said sprocket-wheel, from thence about a sprocket-wheel 80 on the shaft 59, on which the sprocket-roller 58 is fixed, and under and about a sprocket-wheel 81, fixed on a shaft 82, journaled in bearings on the bottom of the frame 1, as most clearly shown in Figs. 1 and 11. On the shaft 82 is fixed a sprocket-wheel 83, which is geared to a sprocket-wheel on the driving-shaft 2 by a sprocket-chain 84. The chain 79 thus causes the sprocket-rollers 58 and 77 to rotate in unison and feed the carrier uniformly forward.

Fixed to the frame 1 immediately beneath the carrier is a heater 85, which may consist of a hollow table having a steam inlet and outlet. As shown, (see Figs. 1 and 11,) the carrier, with the splints depending therefrom,

travels over and above the heater, and the splints are thus heated and their pores opened to prepare the splints for immersion into the paraffin-bath.

Arranged immediately in rear of the heater 85 is a paraffin-tank 86, which is surrounded by a hollow jacket 87, through which steam is caused to circulate in a well-known manner for the purpose of keeping the paraffin in a melted condition. Fixed on a shaft 88, journaled in the frame 1 above the tank 86, is a sprocket-roller 89, under which the carrier 52 passes. The roller 89 deflects or presses the carrier down toward the tank and causes the splints as they are carried forward to dip into the paraffin and be immersed, as most clearly shown in Fig. 11. For the purpose of maintaining the paraffin at a uniform level in the tank 1 provide the following means: Supported on the frame at one side of the tank 86 is a reservoir-tank 90, provided with a heating-jacket 91. Suspended within the tank 90 from the shaft 91^a, journaled in the frame 1, are two bracket-arms 92, connected together by tie-rods 93 (see Fig. 12) and provided with bent arms 94, (see Fig. 1,) by means of which the bracket-arms are rigidly connected to the frame 1 and prevented from turning on the shaft 91^a. Secured between the bracket-arms in any suitable or preferred manner is a pump-barrel 95, from the upper end of which leads a spout 96, that is arranged to discharge into the dipping-tank 86. Fixed on the end of the shaft 91^a immediately above the upper end of the pump-barrel is a chain-wheel 97, provided on its periphery with a plurality of transverse grooves 98, arranged at equal distances apart and adapted for the reception of the pump-buckets 102. A similar chain-wheel 99 is mounted on a shaft 100, carried by the lower ends of the bracket-arms 92. A chain 101 passes around the chain-wheels 97 and 99 and passes centrally through the pump-barrel. On the chain at regular intervals apart are arranged buckets 102, each consisting of a circular disk of approximately the same diameter as the interior diameter of the pump-barrel. On the end of the shaft 91^a opposite to the chain-wheel 97 is a sprocket-wheel 103, and about said sprocket-wheel and a corresponding sprocket-wheel 104, fixed on the drive-shaft 2, is passed a sprocket-chain 105, by means of which the shaft 91^a is rotated to operate the chain 101. The latter is driven in the direction of the arrow shown in Fig. 12 and successively lifts the buckets 102 up through the pump-barrel. The buckets, operating after the manner of pistons, raise the melted paraffin up through the pump-barrel and discharge it into the dipping-tank through the spout 96. An overflow-spout 106 leads from the upper part of the dipping-tank 86 into the reservoir-tank 90, whereby the level of the paraffin in the tank 86 is maintained at a fixed point and the surplus paraffin is conveyed back into the tank 90. A stop-cock 107 is fitted in the lower part of the

dipping-tank and discharges into the reservoir-tank, whereby the contents of the dipping-tank may be drawn off when desired and returned to the reservoir-tank.

5 After leaving the dipping-tank 86 the carrier 52 passes to the sprocket-roller 77 for applying the igniting composition to form the heads of the matches. Supported on the frame 1, beneath the roller 77, is a tank 108,
 10 adapted to contain the igniting composition and provided with a heating-jacket 109, into which steam and water are introduced through an inlet 110 and discharged through an overflow 111. The circulation of the steam and
 15 water through the heating-jacket maintains the composition in the proper paste-like or semiliquid condition. Journaled in the sides of the composition-tank is a shaft 112, on which is fixed a stirrer 113. (Shown most
 20 clearly in Figs. 11 and 13.) Journaled in bearings over the tank 108 is a shaft 114, on which is fixed the composition-roller 115, that turns in the composition contained in the tank. On the corresponding ends of the shafts 78,
 25 112, and 114 are respectively arranged sprocket-wheels 116, 117, and 118, the wheels 116 and 118 being fixed on their shafts, while the wheel 117 is loosely journaled on the shaft 112, so as to rotate independently thereof. A
 30 sprocket-chain 119 is passed around the wheels 116 and 117 and over one side of the wheel 118. As the sprocket-roller 77 is rotated in the manner before described it drives the chain 119, thus rotating the shaft 114, carrying the composition-roller. The sprocket-wheel 117 being loosely journaled on the shaft 112, the chain 119 communicates no motion to the stirrer. As owing to the nature of the composition it is necessary to keep the same
 40 stirred constantly, irrespective of any stoppage of the machine, the stirrer-shaft is in practice rotated by independent means. For this purpose I arrange tight and loose pulleys 120 on the stirrer-shaft 112 and connect it by a belt 121 to a corresponding pulley 122, secured to an overhead-shaft 122^a. For this purpose the drive-shaft 2 will be provided with the usual arrangement of tight and loose pulleys well known to mechanics and connected
 50 with the shaft 122^a by belt 123. The ends of the shaft 114 are journaled in the upper ends of arms 125, which are arranged on the opposite sides of the composition-tank and are loosely fulcrumed on the ends of the shaft 112. Through the lower ends of the arms 125 are passed threaded studs 126, which also pass through segment-shaped slots in the sides of the frame. (See Figs. 1, 13, and 49.) The studs 126 are provided at one end with
 60 heads and at the other end with nuts, whereby said studs may be tightened up to lock the arms 125 in their adjusted positions in a manifest manner. By rocking the arms 125 about the shaft 112 the composition-roller may be swung so as not to come in contact with the splints. Suitably arranged on the upper end of the composition-tank is a scraper 115^a, that

operates to scrape back into the tank the surplus composition that may adhere to the roll.

From the sprocket-roller 77 the carrier is carried back over the frame 1 in a horizontal direction toward the front of the machine and around guide sprocket-wheels 127, by which arrangement the splints are carried for a suitable distance in a vertical or upright
 75 position to permit the composition to set and form smooth and rounded heads.

From the guide-wheels 127 the carrier passes into a cooling-room 128, in which it is led back and forth over guidesprocket-wheels 129, journaled in a frame 130, carrying the treated splints with it. The low temperature of the cooling-room cools and hardens the composition heads of the splints, and from the guide-wheels 129 the carrier passes over guide-wheels 131, journaled in the rear end of the overhead support 74. The carrier then emerges from the cooling-room with the completed and finished matches and travels over the entire length of the said support and around guide-wheels 132, journaled in the front end thereof, and from the latter is led to and around the sprocket-roller 58, driven by the chain 79 in the manner before described, and then passes to the match-ejecting
 85 mechanism, which will now be described.

As shown in Fig. 3, the carrier passes from the roller over the guides 60 and under the roller 62. Fixed in the sides of the frame 3 in advance of the roller 62 (see Figs. 10, 47, and 48) is a cross-bar 133, having a series of perforations corresponding in size and number to the perforations in each of the carrier-bars 55, and arranged above the cross-bar 133 is a cross-bar 134, which is adapted to be reciprocated vertically in slots formed in the frame and carries a series of depending push-rods 135, which at their lower ends pass loosely through the perforations in the cross-bar 133. Fixed on the ends of the cross-bar 133 are uprights 136, through the slotted upper ends of which the ends of the cross-bar 134 pass. Coiled springs 137 are disposed about the uprights 136 and at their lower ends rest on the cross-bar 133 and at their upper ends bear against the ends of and hold elevated the cross-bar 134. Cams 138 are fixed on the shaft 5 and at certain portions of their rotation abut and depress the cross-bar 134 against the action of the springs 137 and force downward the push-rods 135. The carrier passes directly beneath the ejecting mechanism, and when one of the carrier-bars is brought directly beneath the push-rods the cams cause the rods to descend and engage the butts of the matches and force them from out of the perforations in the carrier-bars. In order to perform this operation practically, it is necessary that the carrier be fed beneath the ejecting mechanism with a step-by-step movement. As stated in another part of the description, the carrier between the sprocket-rollers 58 and 62 is slack and sags down, as shown most clearly in Fig. 3, to compensate

for the step-by-step movement of the carrier, which is imparted to the latter by gearing the roller 62 to the roller 54 in the manner before described. The carrier is thus fed beneath the ejecting mechanism to bring one of the carrier-bars directly beneath the push-rods and then remains at rest for a moment, during which the push-rods descend and eject the matches, when the carrier is moved forward another step to bring the succeeding carrier-bar into position, the operating mechanism described being so arranged and timed as to cause these movements to occur, so that when the push-rods descend the carrier will be at rest and when the push-rods ascend the carrier will be fed forward. As the matches are discharged from the carrier-bars they fall into match-boxes fed beneath the ejector in the manner hereinafter described, and in order to cause the matches to fall evenly, regularly, and uniformly into the boxes I provide distributing or spreading mechanism constructed as follows: Pivoted to the opposite sides of the frame 3 is a rocking frame consisting of two arms 139, united at their lower ends by a comb-plate 140, which is provided with forwardly-projecting teeth 141, the spaces between the teeth registering with the perforations in the carrier-bars as the latter are fed beneath the ejecting mechanism. To the upper ends of the arms 139 is attached a rod or shaft 142, which is held in operative engagement with the cams 138 by coiled springs 143, one end of each of which is attached to the rod or shaft 142 and the other end loosely looped around the shaft 5. As the box passes transversely beneath the carrier, the cams 138 operate to actuate the push-rods and eject the matches, the lower ends of which drop between the teeth into the box, and as the cams continue to rotate in the direction of the arrow, Fig. 3, they press back the rod or shaft 142, and thus throw forward the comb-plate 140, which latter operates to lay the matches straight and parallel with one another in the box.

In some cases it is desirable to print the manufacturer's name, trade-mark, or similar matter on one side of each of the match-splints, and in order that this may be accomplished in the course of the manufacture of the splints I provide the following mechanism, which necessitates a slight modification of the splint-cutting mechanism before described.

In the rear and upwardly-extended wall 19 of the hopper 20 is formed a slot or way *a*, in which is fitted to move vertically a slide *b*, (see Fig. 46,) in the lower end portion of which is fixed a spindle *c*, on which the cylindrical block of wood 25 to be cut into splints is adapted to be mounted. Formed centrally in the slide *b* is a slot or way *d*, in which is fitted to move a slide *e*, in the lower end of which is fixed a spindle *f*, on which is journaled the rotary scorer 26, similar in all respects to that before described. The wooden

cylinder 25 rests and is supported upon a printing-cylinder *g*, that bears upon its surface the type-forms adapted to impress the desired characters upon the splints, and said type-forms are inked by the train of inking-rolls *h i j*, which are supplied from an ink-reservoir *k*. In practice I prefer to support a weight *l* on a stud *m*, fixed in the upper end of the slide *e*, which operates to hold the wooden cylinder in contact with the printing-cylinder and the scoring-cylinder in close engagement with the wooden cylinder. Rotary motion is imparted to the printing-cylinder by any suitable means, preferably by mounting said printing-cylinder on the shaft 17 in place of the scoring-cylinder, as before described, and as the wooden cylinder rests on the printing-cylinder and the scoring-cylinder on the wooden cylinder all three of these cylinders will be caused to rotate in unison. The scoring-cylinder operates to form longitudinal slits in the periphery of the wooden cylinder, and a knife 28 operates to plane off the splints thus scored out at the base of the slits in precisely the manner before described. Before the scored portion of the wooden cylinder, however, is acted on by the knife it receives the imprint of the printing-cylinder, and thus each splint is printed on one side before it is severed and drops into the splint-hopper. The slides carrying the scoring and wooden cylinders being freely movable vertically in their ways, said cylinders are fed down automatically by gravity as the diameter of the wooden cylinder is reduced by the knife.

In order to mount one of the wooden cylinders on its spindle *c*, it is necessary to raise both the slides *b* and *e*, and in order to hold them raised while the cylinder is being mounted on its spindle I arrange flat springs *n* in recesses *o*, formed in the walls of the ways *a* and *d*, said springs being fixed at their lower ends, as shown, and at their upper ends bent laterally outward to form shoulders *p*. By raising the slide *b* until its lower end rests on the shoulder *p* of the spring *n* in the way *a* and then raising the slide *e* until its lower end rests on the shoulder of the spring in the way *d* the spindle *c* will be held sufficiently away from the printing and scoring cylinders to permit of the wooden cylinder being slipped onto the spindle. By then disengaging the springs and permitting the slides to drop by gravity the apparatus will be in readiness for operation.

In the foregoing description I have explained the detailed construction and operation of each part of the match-making machine for performing the necessary successive operations for forming the splints and for treating the latter to produce the finished and completed matches, and from the same the combined and continuous operations will be readily understood. The stock is first cut into splints. The splints are distributed and inserted into the carrier-bars, are then heated to open their pores, and are next dipped in

paraffin. The composition heads are then applied and the matches carried to the cooling-room, where the heads are set and hardened. The finished and completed matches are then

5 conveyed to the ejecting mechanism, where the matches are discharged from the carrier into the boxes which have been formed and fed forward by the box-making mechanism, which will now be described.

10 Arranged transversely of the frame 3 is a frame 144, in the forward end of which is removably journaled a shaft 145, on which is fitted the roll or web of strawboard or other material from which the boxes are to be made.

15 From the shaft 145 the web passes over a guide-roller 146, provided at its opposite ends with circumferential flanges 147, which engage the edges of the web and guide the latter accurately between the slitting-rollers.

20 The slitting-rolls are mounted on shafts 148 and 149, journaled one above the other in the sides of the frame 144, and are arranged in two groups of three rolls each, as most clearly shown in Fig. 18. Each of said groups consists

25 of two rolls 150, fixed on the lower shaft 149, and a single roll 151, fixed on the upper shaft 148. The two rolls 150 are arranged at such a distance apart that their inner or adjacent ends are in the same vertical planes

30 as the opposite ends of the roll 151 and the lower edge of the last-named roll lies slightly above the upper edges of the rolls 150. Fitted and secured in recesses formed in the opposite peripheral edges of the roll 151 are segmental and radially-projecting knives or slitters

35 152, and corresponding knives or slitters 153 are similarly fitted in the adjacent ends of the rolls 150. The shafts 148 and 149 are geared together to rotate in opposite directions (the gearing not being shown) and are

40 so arranged that in their revolution the knives will pass opposite each other with a rotary shearing cut, producing two parallel slits or cuts longitudinally in the web and equal in

45 length to the length of the arc formed by the knives or slitters. As stated, there are two groups of knives or slitters, the groups being precisely alike. One of the shafts, as 148, is driven by a sprocket-chain 154, passing about

50 a sprocket-wheel 154^a, fixed on the shaft, said chain in turn being driven in the manner hereinafter described. As the web passes between the slitting-rolls it is longitudinally slitted at regular intervals, as at 155, Fig. 17, to form

55 the sides of the end flaps 156 and 206 of the box-blank, which flaps are completed or finished as hereinafter explained.

From the slitting-rolls the web passes to the gluing device, comprising a tank 157, supported on rods 158, attached to the sides of the frame 144 and adapted to contain liquid glue or paste. Journaled in the sides of the frame

60 above the glue-tank is a shaft 159, on which are fixed two sleeves 160 and 161, respectively formed with peripheral segments 162 and 163, as most clearly shown in Figs. 20 and 21. The segments 162 and 163 are arranged on the

shaft 159 in different vertical planes and in such manner that the segments alternate with one another—that is to say, the segment 162

70 lies opposite the space between the ends of the segment 163. Journaled in the sides of the frame 144 is a pressure-roll 164, geared with the shaft 159 and having fixed on its end a sprocket-wheel 165; which is driven by the

75 chain 154. The segments 162 and 163 revolve or dip in the glue in the tank 157, and the surplus glue is removed from the faces of the segments by a scraper-blade 166, attached to the upper edge of one end of the tank. As

80 the web passes between the pressure-roll 164 and the glue-roll the segments rotate in contact with the under side of the web, the segment 162 applying glue to the outer corners 167 of two of the end flaps of the box-blank

85 and the segment 163 applying the glue in a long strip 169 to the flap 168.

From the gluing-rolls the web passes to a sanding device comprising a box 170, supported between the sides of the frame 144

90 and containing a quantity of sand. In the ends of the box 170 is journaled a shaft 171, on which is fixed a cylinder 172, provided at one end with a plurality of radial paddles 173. (Best shown in Figs. 22 and 23.) The

95 sanding-cylinder should revolve relatively faster than the slitting and gluing rolls, and to this end I fix on the end of the shaft 149 a sprocket-wheel 174, (shown in dotted lines in Fig. 15,) which is geared by a sprocket-

100 chain 175 to a smaller sprocket-wheel 176 on the shaft 171. The sanding-cylinder rotates in the sand contained in the box 170 and is arranged at such a point on the shaft 171 that as the web passes over the sand-box the pad-

105 dles 173 take up and throw the sand against the glued strip 169, previously applied by the segment 163 to the top flap 168 of the box-blank, the sand adhering to the glue and forming a striking-surface for igniting the matches.

110 The web passes from the sanding device to the scoring mechanism, consisting of a pressure-roller 177, journaled in the sides of the frame, and a shaft 178, journaled in the frame directly beneath the pressure-roller and having

115 mounted thereon four serrating-disks 179. (Most clearly shown in Figs. 24 and 25.) The disks 179 are of uniform diameter and each is serrated on its periphery to form teeth 180, a portion of the disk, as 181, being mutilated or cut away, so that there shall be a

120 portion of the disk unprovided with teeth. The disks are arranged on the shaft 178 and are held at the proper distances apart by sleeves 182. One of the sleeves 182 bears

125 against a shoulder 183, formed on the shaft 178, and the sleeve at the other end is engaged by a nut 184, threaded upon said shaft. By screwing up the nut the disks are firmly clamped on the shaft against rotation on the

130 latter. The serrated disks are so arranged on the shaft that the mutilated portions of the disks will register with each other, and the shaft is geared to rotate with the impres-

sion-roller 177. On the end of the impression-roller is fixed a sprocket-wheel 185, which engages with the chain 154, and thus operates the scoring mechanism. As the web passes between the impression and scoring rollers the teeth of the serrated disks indent the web longitudinally in four parallel lines 186, (see Fig. 17,) upon which lines the blank is afterward folded to form the sides 187 of the box, the mutilated portions of the serrating-disks rotating opposite the edges 155 of the top end flaps 156. Instead of merely indenting the strawboard-web the teeth of the disks may be caused to penetrate it, and I prefer to form circumferential grooves in the periphery of the pressure-roller, which register with said teeth.

From the scoring-rolls the web passes to the printing, cutting, and scoring mechanism, which I will now describe. Between the sides of the frame is journaled a roll 188, formed with a printing-cylinder 189, provided with a recess 190, which extends around the major portion of the periphery of the cylinder and in which is fitted an electroplate or other suitable printing-surface 191. On the ends of the printing-cylinder are formed cams 192, which project beyond the circumference of the cylinder, as most clearly shown in Figs. 26 and 27, and are in alinement with the space between the ends of the electroplate. Journaled in the frame immediately above the printing-cylinder is a pressure-roller 193, which rotates practically in contact with the printing-roller and between the inner or adjacent sides of the cams 192. The printing-surface 191 of the cylinder rotates in contact with an inking-roller 194, which is supplied with ink from a reservoir 195 by a train of distributing-rollers 196. That portion of the inking-roller 194 which rotates in contact with the printing-cylinder is preferably formed with a gelatin or other suitable elastic or yielding surface 197, while the ends 198 thereof, which are engaged by the cams 192, are formed of metal. The trunnions 199 of the inking-roller are journaled in slots 200, formed in the sides of the frame 144, said slots being inclined upward and away from the printing-roller, whereby when the cams 192 rotate in contact with the inking-roller the latter is lifted out of contact with the printing-cylinder, and when the cams pass out of engagement with the inking-roller the latter again drops by gravity into contact with the printing-surface. In this manner the ink is applied only to the electroplate. Near one end of the printing-cylinder a circumferential groove 201 is formed, which registers with the glued and sanded portions of the web as the latter passes over the cylinder and prevents the cylinder from coming in contact therewith. Two longitudinal grooves 202 are formed in the printing-cylinder between the cams, in each of which is securely fitted a scoring and cutting blade 203. The scoring edges 204 of the blades project slightly beyond the periphery of the

printing-cylinder and operate to indent the web transversely on the lines 205, upon which the end flaps 156 and 206 of the box-blank are subsequently bent. Each blade is also provided with two cutting edges 207, which project still farther beyond the periphery of the cylinder and operate to cut entirely through the web and sever the portions lying between the edges 155 of the end flaps 156 and 206. The pressure-roller is preferably provided with grooves on its periphery adapted to register with the edges of the blades 203. The pressure and printing rolls are geared to rotate together, and the former is driven by sprocket-wheel 208, engaging the chain 154.

In operation the web passes between the pressure-roll and printing-cylinder, and the blades 203 score the blank on the lines 205 to turn down end flaps 156 and to turn up end flap 206 and cut out the previously-slit portions between said flaps. The electroplate then comes in contact with and prints the under side of the web, during which operation the cams 192 engage the inking-roller 194 and move it out of contact with the printing-cylinder. When the cams have disengaged the inking-roller, the latter drops back into contact with the electroplate to ink the latter, and the scoring and cutting blades are again brought into operation to cut and score the other end of the blank. The blades 203 may score a greater or less distance than that shown and described or score the entire distance across the blank and may also be constructed to cut a greater or less distance.

The blanks leave the printing, cutting, and scoring mechanism completed excepting that they are not severed from one another. For this purpose I provide a severing or cutting-off device constructed as follows: Journaled one above another in the sides of the frame 144 are two square shafts 209 and 210, on one of the faces of each of which is fastened a knife, said knives being respectively designated by the numerals 211 and 212, as most clearly shown in Figs. 29 and 30. Each of the knives projects at one side beyond the edge of its shaft, and said projecting portions are provided with beveled cutting edges 213 and 214. As shown in Fig. 29, the cutting edge of each of the knives is longitudinally inclined to the axis of the shaft on which the knife is fixed, and the higher or wider ends 215 and 216 of said knives are arranged opposite to each other or at the corresponding ends of their shafts, whereby as the knives rotate the flat or unbeveled sides thereof glide past one another and their inclined edges produce a shearing cut. The web passes between the two knives, and as the latter are rotated they approach and pass one another, the higher or wider ends 215 216 first meeting and commencing to sever the web at one edge thereof, and as the knives move forward in their rotation with the forward movement of the web the knives continue to pass one another with a shearing cut, thus completely

severing the web transversely from side to side and cutting off the blank. The shafts 209 and 210 are geared together to rotate in opposite directions, and on one of them is fixed a sprocket-wheel 217, (see Fig. 1,) which is engaged by a sprocket-chain 218, which in turn is driven in a manner to be hereinafter described.

When one-half the length of the blank is fed forward from a vertical line passing through 209 and 210, its forward end is seized by the folding and conveying mechanism, which will be now described.

Journalled one above another in the sides of the frame are two shafts 219 and 220, the distance between the vertical centers of which and the centers of the shafts 209 and 210 corresponds to one-half the length of one of the box-blanks. The shaft 219 is rotated by a sprocket-wheel 221, fixed on the end of the shaft and engaging the drive-chain 154. On the shafts 219 and 220 are respectively arranged rolls 222 and 223, and passing about the roll 223 is an endless apron 224, that also passes about a roller 225, journalled in the rear end of the frame 144. The roll 223 is not geared to any other moving part, but runs loosely or freely in its bearings. Attached to the frames intermediate the rollers 223 and 225 is a bracket 226, which supports two vertically-adjustable arms 227, in the lower ends of which is journalled a belt-tightener roller 228. By raising or lowering the arms 227, carrying the roller 228, the tension of the apron may be adjusted in an obvious manner. Rigidly attached to the endless apron at uniform distances apart are transverse slats 229, the distance between each two adjacent slats being approximately equal to the length of the folded or completed box. The endless apron is passed between the rolls 222 and 223 in intimate contact with both and is actuated or driven by the roll 222. A groove or recess 230 is formed longitudinally in the face of the roll 222 from end to end of the latter, as most clearly shown in Fig. 31, the walls 231 and 232 of which are straight and formed radially to the axis of the roller. The segmental or partially-cylindrical face 233 of the roll 222 corresponds to the length of the folded or completed box, while the recess or space included between the walls or shoulders 231 and 232 corresponds to the combined lengths of the two end flaps 206. As before stated, the endless apron 224 is actuated by being fed forward between the rolls 222 and 223, and it will be manifest that when the recess or grooved portion 230 of the roll 222 comes opposite the periphery of the under or idle roll 223 the latter will cease to rotate and the apron will remain stationary until again engaged by the periphery of the roll 222. The apron has thus imparted to it an intermittent movement. The rolls 222 and 223 are so arranged relatively to the apron 224 and to the shearing-knives 211 and 212 that as the wall 231 of the roll 222 passes the vertical center

of the rolls 222 223 and rotates away from the roll 222, as shown in Fig. 40, the apron remains stationary with one of the slats 229 standing upright in the recess 230. As the web continues to be moved forward the slat 229 still remains stationary, and in the further rotation of the roll 222 the wall 232 engages the end flap 206 of the web or blank, turning it up on the scored line 205 and folding it against the slat 229, as shown in Fig. 41. The blank and apron are now grasped between the periphery of the roll 222 and the roll 223 and are both carried forward. As the wall 232 approaches the slat 229 it seizes the succeeding box or blank, as shown in Fig. 41, and as the rolls continue to revolve the flap is turned square and folded between the said slat and wall, as shown in Figs. 41 and 42. As has been before stated, the distance between two adjacent slats is approximately equal to the length of the bottom of the folded or completed box. Hence the roller operating in the manner above described will turn up the end flaps 206 of the blank between the slats. The blanks with their turned-up ends are intermittently fed forward by the apron beneath the match ejecting and packing mechanism described in the first part of this specification, and the matches are deposited therein in the manner before explained.

Fastened to the sides of the frame 144 are brackets 233^a, to the under side of which are attached downwardly depending formers, each consisting of flat parallel plates 234, the lower edges of which lie just above and in proximity to the edges of the bottoms of the boxes, as shown in Fig. 32. The matches and slats 229 travel transversely between the formers 234, and the latter extend nearly to the rear end of the frame 144. Attached to the sides of the frame 144, beneath the apron, are brackets 235, to which are secured folders, which consist of flat plates 236, arranged parallel to each other and upon opposite sides of the formers 234. The upper edges of the folders 236 are inclined, as shown in Fig. 38, commencing at a point at their forward ends and inclining upwardly and rearwardly until they attain a height approximately level with the upper edges of the formers 234, as shown at 237. From the point 237 to the rear of the folders the latter are provided with turning-flanges 238, which extend horizontally inward at right angles to the folders, and the adjacent edges of said flanges are gradually tapered from their forward toward their rear ends, as most clearly shown in Fig. 38.

In operation the blanks having the end flaps turned up, as described, are carried forward with their charge of matches by the apron under the folders 234, the sides and top flaps of the blanks extending horizontally on both sides of the apron, as shown in Fig. 32, and upon reaching the inclined upper edges of the folders 236 the sides and top flaps are gradually folded upright against the

formers 234, as progressively shown in Figs. 33, 34, and 35. Upon reaching the point 237 the beveled ends of the turning-flanges 238 engage the top flaps 168 and gradually fold them inward and over the upper edges of the formers, as shown in Fig. 36. In practice one of the turning-flanges 238 will increase in width faster than the other, whereby the flap having the unglued ends or corners 167 will be turned in and folded down before the opposite flap. The boxes thus arrive at the rear end of the formers and folders completed and filled with matches, with the exception of having their end flaps 156 folded down and the glued corners united with the end flaps of the bottom by pressure. This is accomplished as follows: Fixed to the opposite sides of the rear ends of the frame 144 are brackets 239, between which are supported two vertical and parallel plates 240, which form the sides of the box-discharge chute 241. (Most clearly shown in Figs. 16 and 39.) Two parallel plates 242 are fixed transversely between the plates 240 and in connection with the latter form the upper end of the chute 241. The plates 242 are fixed at a distance apart equal to the length of a completed box, and their upper edges are bent or inclined outwardly, as shown at 243, to form a flaring mouth for the reception of the boxes and operate as folders to fold in the previously-turned-up end flaps 206 of the boxes. The said inclined edges 243 of the plates are arranged in approximately the same horizontal plane as the apron 224. Journaled in the plates 240, between the ends of the formers and the foremost plate 242, is a shaft 271, on which is fixed a delivery-roller 244, the upper edge of which lies in the same plane as the apron and the flaring edges of the plates 242. The rear ends of the formers extend into close proximity to the delivery-roll 244, as shown, so as to hold the rear end of the box and prevent the latter from tipping until the box has been fairly discharged onto the flaring mouth of the discharge-chute. Arranged to reciprocate between the plates 240 and between guides 245, fastened to the latter, is a plunger 246, which is hung on a cross-rod 247, that is free to move vertically in slots 248, formed in the plates 240. Fixed in the outer ends of the cross-rod by pins 249 are vertical rods 250, the lower ends of which are loosely guided in brackets 251, fastened to the brackets 239 and the sides of the frame. Coiled springs 252 are arranged on the rods 250 between the brackets 251 and the cross-rod 247 and operate to hold the plunger 246 elevated. A shoulder 253 is formed on the upper end of the plunger and is engaged by a cam 254, fixed on a shaft 255, journaled in the upper ends of the plates 240. A sprocket-wheel 256 is mounted on one end of the shaft 255, around which passes the chain 154, which actuates the slitting, gluing, serrating, printing, and folding rolls before described. The chain passes under an idle guide-roll 257, jour-

naled in bearings on the top of the frame 144, and also passes around a sprocket-wheel 258, fixed on a counter-shaft 259, that is driven by a chain 259^a, passing around a sprocket-wheel fixed on a shaft 260, as shown in Fig. 1. The shaft 260 receives its motion from the drive-shaft 2 of the machine by suitable bevel-gearing. (Most clearly shown in Fig. 11.) Journaled in the sides of the plates 240, near the lower ends of the plates 242, are shafts 261 and 262, and on said shafts are respectively fixed rolls 263 and 264. The peripheries of the rolls lie in close proximity to the lower edges of the plates 242, and about said rolls pass endless belts or aprons 265 and 266, which also pass about corresponding rolls 267 and 268, journaled in the lower ends of the plates 240 in the same vertical planes with the rolls 261 and 262. Pivoted to the plates 240 are arms 269, in the free ends of which are journaled belt-tightener rollers 270. By any suitable means (not shown) the arms may be thrown inward or outward to adjust the tension of the endless belts 265 and 266. The belts form a continuation of the plates 242 and aid in forming two sides of the discharge-chute 241. On the shaft 255 is fixed a sprocket-wheel 272, which is geared by a sprocket-chain 273 to a smaller sprocket-wheel 274 on the shaft 271. As before stated, the delivery-roll 244 is fixed on the shaft 271 and is driven from the cam-shaft 255. Owing to the difference in size of the sprocket-wheels 272 and 274 a rapid rotation is imparted to the delivery-roller 244, whereby as the boxes leave the apron and the formers and folders they are swept forward with a swift movement by the delivery-roller squarely over the flaring mouth of the discharge-chute 241. As each box is placed over the mouth of the discharge-chute the cam 254 forces the plunger down. The plunger carries on its lower end a platen provided at its opposite ends with downwardly-inclined flanges 275. As the plunger forces the box down into the discharge-chute the inclined flanges 275 fold the end flaps 156 down squarely and in the plunger's further downward movement will force the box down below the flaring edges 243 and turn up flaps 206 squarely and against glued flaps 156. As the box is pressed down by the succeeding boxes into the chute the plates 242 press the end flaps firmly together, thus causing the glued portions 167 of the end flaps 156 to adhere to the adjacent end flaps 206, thereby entirely completing the closure of the box. Each box thus completed is forced down by the box above and passes out from between the plates 242 to the belts 265 and 266, which grasp the ends with a yielding pressure. The belts move down with the boxes and hold the ends pressed together for a sufficient length of time to permit the glue to firmly adhere and effectually hold the end flaps down in place. The belts 265 and 266 discharge the filled boxes onto a table in readiness for packing into parcels suitable for the market.

Having described my invention, what I claim is—

1. In an organized continuous match making and boxing machine, the combination with mechanism for making the matches and discharging them in successive rows, of mechanism for cutting and folding the boxes from a single integral piece of material and feeding the partially-made boxes successively in a continuous line across the range of discharge of and parallel to said rows, and means for folding the integral box-blanks about the matches, substantially as described.

2. In an organized continuous match making and boxing machine, the combination with mechanism for making the matches and discharging them in successive rows, of mechanism for successively cutting integral blanks from a single piece of material and for partially folding said blanks into boxes, mechanism for feeding the partially-made boxes successively in a continuous line across the range of discharge of and parallel to said rows, and means for folding the integral blanks about the matches to completely inclose the latter, substantially as described.

3. In an organized continuous match making and boxing machine, the combination with mechanism for making the matches and discharging them in successive rows, of mechanism for successively cutting integral blanks from a single piece of material and for partially folding said blanks into boxes, mechanism for feeding the partially-made boxes successively in a continuous line across the range of discharge of and parallel to said rows, means for folding the integral blanks about the matches to completely inclose the latter, and means for cementing the folded box together, substantially as described.

4. In an organized continuous match making and boxing machine, the combination with mechanism for making the matches and discharging them in successive rows, of mechanism for successively cutting integral blanks from a single piece of material and for partially folding said blanks into boxes, mechanism for feeding the partially-made boxes successively in a continuous line across the range of discharge of and parallel to said rows, means for laying the discharged matches in horizontal rows in the boxes, and means for folding the integral blanks about the matches to completely inclose the latter, substantially as described.

5. In a match-making machine, the combination with a rotary cylinder provided on its periphery with a plurality of longitudinal, radially-projecting knives, means for rotatably supporting a cylindrical block of wood upon the top of the knife-cylinder, a stationary cutter arranged tangentially to the knife-cylinder to sever the splints from the cylindrical block, means for adjusting the cutter toward and from the knives, driving mechanism for positively rotating the knife-cylinder, and means for automatically feeding the cylindrical block downward by gravity upon the knife-cylinder as the splints are cut off by the cutter, substantially as described.

6. In a match-making machine, the combination with a rotary cylinder provided upon its periphery with a plurality of longitudinal knives, and driving mechanism for positively rotating the knife-cylinder, of a vertical slide arranged to move freely in guides fixed above the knife-cylinder, a fixed spindle carried by the slide parallel with and in approximately the same vertical plane as the knife-cylinder, said spindle forming the axis of a cylindrical block of wood in the periphery of which the knives operate to cut longitudinal incisions, and a stationary cutter arranged to plane off the block at the base of said incisions, substantially as described.

7. In a match-making machine, the combination with a rotary cylinder provided on its periphery with a plurality of radial knives, and driving mechanism for positively rotating the knife-cylinder, of means for feeding a cylindrical block of wood by gravity onto, and into rotatable contact with, the knife-cylinder, and a flat, horizontal knife adjustably arranged with its cutting edge tangential to the circular plane described by the cutting edges of the rotary knives, substantially as described.

8. In a match-making machine, the combination with a carrier having transverse, perforated carrier-bars, and mechanism for inserting the splints endwise in the carrier-bars, of a feeder arranged horizontally above the splint-inserting mechanism, said feeder consisting of a plurality of parallel flat plates mounted on fixed supports and distance-pieces arranged between the opposite ends of the plates and operating to hold the plates at such distance apart that but a single match is permitted to pass at a time between two adjacent plates to the splint-inserting mechanism, a hopper supported above the feeder, and means for discharging the splints from the hopper horizontally between said plates, substantially as described.

9. In a match-making machine, the combination with a carrier having transverse, perforated carrier-bars, and mechanism for inserting the splints endwise in the carrier-bars, of a feeder arranged horizontally above the splint-inserting mechanism, said feeder consisting of a plurality of parallel flat plates perforated near their opposite ends and mounted on two rods passed through said perforations, distance-pieces arranged on the rods between the plates and operating to hold the latter at such distances apart that but a single match is permitted to pass at a time between two adjacent plates to the splint-inserting mechanism, nuts threaded onto the rods to hold the plates and distance-pieces in place thereon, a hopper supported above the feeder, and means for discharging the splints from the hopper horizontally between said plates, substantially as described.

drical block downward by gravity upon the knife-cylinder as the splints are cut off by the cutter, substantially as described.

70

75

80

85

90

95

100

105

110

115

120

125

130

10. In a match-making machine, the combination with a shaft, a sprocket-wheel fixed on the shaft, and an endless carrier passed about the sprocket-wheel and having transverse, perforated carrier-bars, of a table arranged to reciprocate toward and from the carrier and at a right angle thereto, means carried by the table for inserting the splints in the carrier-bars, a driven shaft, a cam fixed on the driven shaft and engaging the table to force it forward to insert the splints, a ratchet-wheel on the sprocket-wheel shaft, a pivoted lever, a pawl on one end of said lever in engagement with the ratchet-wheel, and mechanism actuated by the driven shaft for oscillating the lever to impart a step-by-step rotary movement to the sprocket-wheel and intermittingly move forward the carrier, substantially as described.

11. In a match-making machine, the combination with a shaft, a sprocket-wheel fixed on the shaft, and an endless carrier passed about the sprocket-wheel and having transverse, perforated carrier-bars, of a table arranged to reciprocate toward and from the carrier, means carried by the table for inserting the splints in the carrier-bars, a driven shaft, a cam fixed on the driven shaft and engaging the table to force it forward to insert the splints in the carrier-bars, a spring for retracting the table, a ratchet-wheel on the sprocket-wheel shaft, a pivoted lever, a pawl on one end of said lever in engagement with the ratchet-wheel, an eccentric fixed on the driven shaft, and a connecting-rod connected to the lever at the end opposite the pawl and actuated by the eccentric, the cam and eccentric being set on the driven shaft as shown, whereby the carrier is fed forward while the table is stationary, and the table is fed forward when the carrier is stationary, substantially as described.

12. In a match-making machine, the combination with the carrier, the paraffin dipping-tank, of a reservoir-tank, a frame suspended from a shaft, a pump-barrel supported on said frame and projecting at its lower end into said reservoir-tank, a sprocket-wheel fixed on the said shaft, an endless chain passing about said sprocket-wheel and through the pump-barrel, a plurality of buckets arranged on the chain, a spout leading from the pump-barrel to the dipping-tank, and an overflow-pipe and a valved discharge-pipe leading from the dipping-tank to the reservoir-tank, substantially as described.

13. In a match-making machine, the combination with the carrier constructed to hold the match-splints, of a composition-tank supported beneath the carrier, a stirrer arranged in the tank, a swinging frame arranged on the opposite sides of the tank, a composition-roller journaled in the upper ends of said frame so as to turn in the composition and arranged to be swung by said frame into and out of operative position, means for locking said

frame against movement, and means for driving the composition-roller and stirrer independently of each other, substantially as described.

14. In a match-making machine, the combination with a sprocket-wheel fixed on a driven shaft and the endless carrier passing about the same, of the composition-tank supported beneath the sprocket-wheel and carrier, a stirrer-shaft journaled in the sides of the tank, a stirrer fixed thereon, a sprocket-wheel loosely journaled on the end of the stirrer-shaft, a shaft journaled above the tank, a composition-roller fixed on said shaft and operating to turn in the tank, a sprocket-wheel fixed on the end of the driven shaft, a sprocket-chain passed around the said sprocket-wheel and the loose sprocket-wheel on the stirrer-shaft and over one side of the sprocket-wheel on the composition-roller shaft, and independent means for rotating the stirrer, substantially as described.

15. In a match-making machine, the combination with a driven shaft, a sprocket-wheel fixed thereon and the endless carrier passed about the sprocket-wheel, of the composition-tank supported beneath the sprocket-wheel and carrier, a stirrer-shaft journaled in the sides of the tank, a stirrer fixed thereon, a sprocket-wheel loosely journaled on the end of the stirrer-shaft, a swinging frame, a shaft journaled in said frame above the tank, a composition-roller fixed on said shaft and operating to turn in the tank, a sprocket-wheel fixed on the end of the driven shaft, a sprocket-chain passed around the said sprocket-wheel and the loose sprocket-wheel on the stirrer-shaft and over one side of the sprocket-wheel on the composition-roller shaft, independent means for rotating the stirrer, and means for holding the swinging frame against movement, substantially as described.

16. In a match-making machine, the combination with the endless carrier having transverse, perforated bars for holding the matches, of means for intermittingly feeding forward the carrier horizontally, means for ejecting the matches from each of the carrier-bars successively, an oscillating spreading device arranged to oscillate longitudinally beneath the carrier, mechanism for swinging said spreading device forward to strike the matches as they drop from the carrier and lay them out flat and parallel in a receptacle, and means for swinging the spreading device rearward out of the path of the matches as they are ejected, substantially as described.

17. In a match-making machine, the combination with the endless carrier having transverse, perforated bars for holding the matches, of means for intermittingly feeding forward the carrier horizontally, means for ejecting the matches from each of the carrier-bars successively, an oscillating spreading device provided with a comb-plate having parallel teeth, and means for swinging said

plate forward to engage the matches as they drop from the carrier and lay them out flat and parallel in a receptacle, substantially as described.

5 18. In a match-making machine, the combination with the endless carrier having transverse, perforated bars for holding the matches, of means for intermittently feeding forward the carrier horizontally, means for
10 ejecting the matches from each of the carrier-bars, successively, an oscillating frame provided at its lower end with a spreading device arranged to swing longitudinally beneath the carrier to engage the matches as
15 they drop from the carrier and lay them flat and parallel in a receptacle, a cam rotating in engagement with the end of the frame and operating to swing the spreader into engagement with the matches, and a spring for retracting the spreader, substantially as described.

19. In a match-making machine, the combination with the endless carrier having transverse, perforated carrier-bars for holding the
25 matches, of means for intermittently feeding forward the carrier horizontally, a vertically-reciprocating frame arranged above the carrier, push-rods carried by the frame and arranged to register with the perforations of
30 each of the carrier-bars successively, an oscillating frame provided at its lower end with a spreading device, a rotary cam engaging the upper ends of said reciprocating and oscillating frames and operating to alternately
35 force the push-rods down to eject the matches and swing forward the spreader to engage the matches and lay them parallel in a receptacle, and means for retracting the said frames, substantially as described.

40 20. In a match-making machine, the combination with the endless carrier having transverse, perforated bars for holding the matches, of means for intermittently feeding forward the carrier horizontally, means for simultaneously ejecting the matches from each
45 of the carrier-bars successively, a box-carrier arranged transversely beneath the match-carrier, means for intermittently feeding forward the box-carrier to periodically place a
50 box beneath the ejecting mechanism, a spreader arranged to engage the matches as they drop from the match-carrier and lay them parallel and horizontally in the boxes, and folding mechanism arranged to close the
55 boxes, substantially as described.

21. In an organized continuous match making and boxing machine, the combination with mechanism for making the matches and discharging them in successive rows, of mechanism for successively cutting from a continuous web of paper integral blanks and for turning up the ends of the blanks to partially form boxes, an endless carrier for feeding the partially-made boxes successively in a continuous line across the range of discharge of
65 and parallel to said rows, and formers and folders constructed and arranged to fold the

sides and ends of the integral blanks about the matches to completely inclose the latter, substantially as described. 70

22. In an organized machine, the combination with match-making mechanism, an endless carrier arranged to hold and convey the match-splints, and match-ejecting mechanism, of box-blank-forming mechanism, means
75 for gluing the ends of the blanks, a folder arranged to turn up the ends of the blanks, a carrier arranged to successively and intermittently feed the turned-up blanks to the ejecting mechanism to receive the matches, 80 formers and folders arranged to fold the side and top flaps of the boxes, and a folder for pressing down the glued ends of the boxes, substantially as described.

23. In an organized machine, the combination with match-making mechanism, an endless carrier arranged to hold and convey the match-splints, and match-ejecting mechanism, of box-blank-forming mechanism, means for gluing the end flaps and one of the top
90 flaps of each blank, a sanding device for applying sand to the glued top flap, a folder arranged to turn up the ends of the blanks, a carrier arranged to successively and intermittently feed the turned-up blanks to the ejecting
95 mechanism to receive the matches, formers and folders arranged to fold the side and top flaps of the boxes, and a folder for pressing down the glued ends of the boxes, substantially as described. 100

24. In an organized machine, the combination with match-making mechanism, an endless carrier arranged to hold and convey the match-splints, and match-ejecting mechanism, of mechanism arranged to cut and score
105 a continuous web to successively form box-blanks, a cutter for separating the blanks, a folder for turning up the ends of the blanks, a carrier arranged to successively and intermittently feed the turned-up blanks to the
110 ejecting mechanism to receive the matches, formers and folders arranged to fold the side and top flaps of the boxes, and a folder for pressing in the ends of the boxes, substantially as described. 115

25. In an organized machine, the combination with match-making mechanism, an endless carrier arranged to hold and convey the match-splints, and match-ejecting mechanism, of mechanism arranged to cut and score
120 a continuous web to successively form box-blanks, printing mechanism for printing the blanks, a cutter arranged to separate the cut, scored and printed blanks, a folder arranged to turn up the ends of the blanks, a carrier
125 arranged to successively and intermittently feed the turned-up blanks to the ejecting mechanism to receive the matches, formers and folders arranged to fold the top and side flaps of the boxes, and a folder for pressing
130 in the ends of the boxes, substantially as described.

26. In a match-making machine, the combination with a rotary cylinder provided upon

its periphery with a plurality of longitudinal knives, of means for supporting a cylindrical block of wood in rotatable contact with the knife-cylinder whereby the knives operate to
5 form a series of longitudinal incisions in said block, a cutter arranged to shear off the outer portion of the cylindrical block at the base of said incisions, and a printing-cylinder arranged to rotate in contact with the said cylindrical block at a point between the knives
10 and cutter, whereby the printing-cylinder operates to print the splints after they have been divided longitudinally and before they are severed from the wooden cylinder, substantially as described:
15

27. In a match-making machine, the combination with a rotary cylinder provided on its periphery with a plurality of radial knives and driving mechanism for positively rotating

the knife-cylinder, of means for feeding a cylindrical block of wood by gravity onto and into rotatable contact with the knife-cylinder, and a flat horizontal knife adjustably arranged with its cutting edge tangential to the circular plane described by the edges of the rotary knives, the axis of the knife-cylinder being disposed to one side of a vertical line passing through the axial center of the cylindrical block of wood, substantially as described and for the purpose specified. 20 25 30

In testimony whereof I have hereunto set my hand in presence of two subscribing witnesses.

EDWARD H. EISENHART.

Witnesses:

ALBERT H. NORRIS,
F. B. KEEFER.