



- 1
- 2a 1
- 2b 2a (C)
- 3 2a A-A
- 4 2a B-B
- 5
- 6

< >

10:  
20:  
30:  
40:  
60:  
70:  
80:

(foil bearing)

0.1 0.3 mm

가

가

가

가

가

가



가 (20) (30) 가 (20) (10)  
(23a)  
가 (20) 가  
3 (20) (40) (28) (50) 가  
(40) (60) (30) (60) 가  
(60)가  
1 (70)가 (10) (80) ( )  
(80) (10) 가 (80) ( )  
70) (10) (40) (30) (10) 가 (10)  
(60) (40) (60) (40) (30) (10)  
가 (60) " " (10) ( )  
(80) (60) 가  
5 (20) 가  
(t<sub>2</sub>) (10) (10) (10) ( ) 가  
( ) ( ) 가 (20) 가  
(100) (10) 가 (t<sub>0</sub> t<sub>1</sub>),  
(60) (40) (30) 가 ( ) 가 (t<sub>1</sub> t<sub>2</sub>),  
(30) (60) 가 (20) 가 (30) (t<sub>2</sub> t<sub>3</sub>),  
(10) 가 (100) 가 ( ) (10) 가 (60)  
(10) ( ) (t<sub>4</sub>) 0 (t<sub>2</sub> t<sub>3</sub>), (30)  
(30)  
(10) (20) (10) 가 (t<sub>3</sub>  
t<sub>4</sub>), (20) ( ) (10) 가 ( )  
가 (100) (10) 가 (t<sub>3</sub> t<sub>4</sub>),  
(80) (60) (40) (30)  
(30) (100) 가 ( )  
5 (100) 가 ( )  
30) 가 가 ( )  
가 가 ( )  
10) (20) 6 (140) ( )  
(200)  
(140) (10) (20) (30) ( )  
(140) (120) (40) (40) ( )  
120) (160)가 (40) (180) (10) 가  
(180) (70) (10) (40) (30) (10) 가  
(10) 가 (60) (40) (60) (30) (40) ( )  
30) (10) 가 (60) (180) (40) ( )  
(40) (60) (180) (70)  
(160)



8 ,

10.  
7 ,

11.  
7 10 ,

가 ,

12.

13.

14.

15.

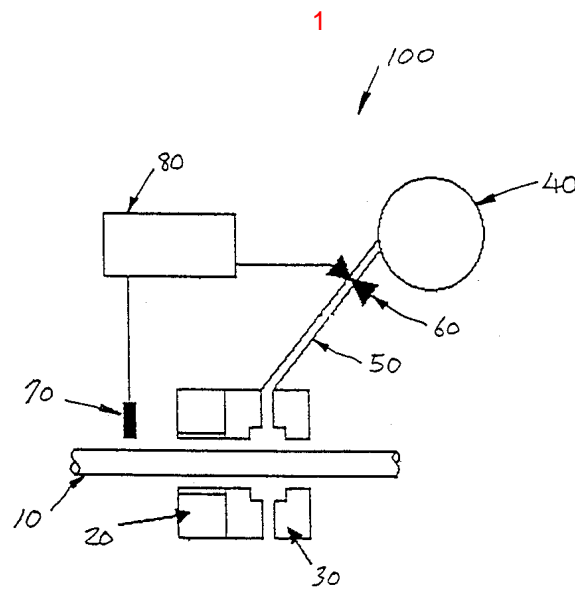

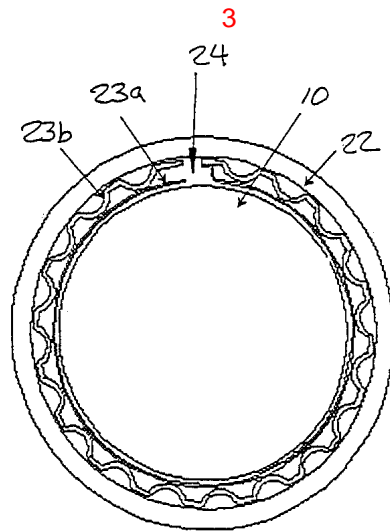
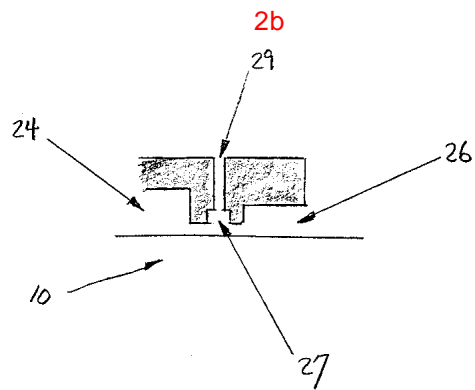
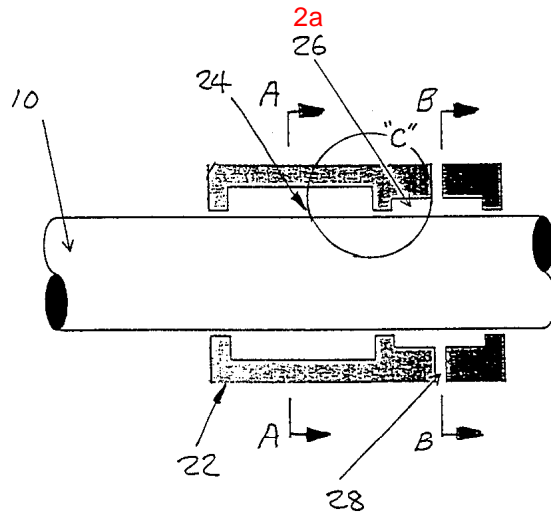

4

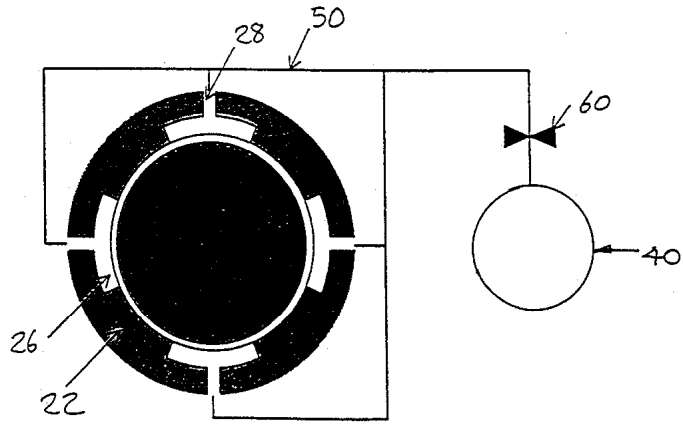

5

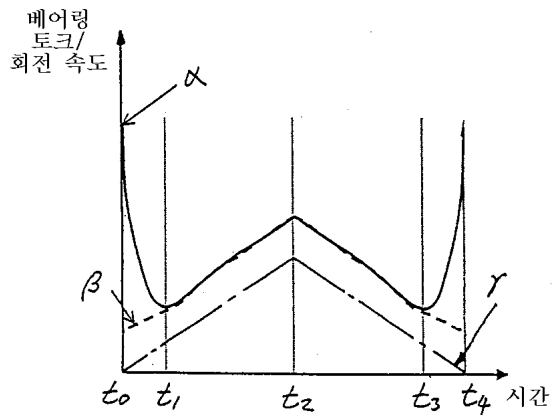

6

