

A&A Ref: 152862

PUBLICATION PARTICULARS AND ABSTRACT
(Section 32(3)(a) - Regulations 22(1)(g) and 31)

21	01	PATENT APPLICATION NO	22	LODGING DATE	43	ACCEPTANCE DATE
----	----	-----------------------	----	--------------	----	-----------------

2005/05366

1 July 2005

7-2-06

51	INTERNATIONAL CLASSIFICATION	NOT FOR PUBLICATION
----	------------------------------	---------------------

A61F

CLASSIFIED BY: **ISA**

71	FULL NAME(S) OF APPLICANT(S)
----	------------------------------

The Procter & Gamble Company

72	FULL NAME(S) OF INVENTOR(S)
----	-----------------------------

**BUSAM, Ludwig
DIVO, Michael
ENGEL, Roland**

**BECKER, Uwe Jürgen
EHRNSPERGER, Bruno Johannes
LINDNER, Torsten**

EARLIEST PRIORITY CLAIMED	COUNTRY	NUMBER	DATE
	33	EP(DE) 31	03002678.5 32
			12 February 2003

NOTE: The country must be indicated by its International Abbreviation - see schedule 4 of the Regulations

54	TITLE OF INVENTION
----	--------------------

Thin and dry diaper

57	ABSTRACT (NOT MORE THAN 150 WORDS)
----	------------------------------------

NUMBER OF SHEETS	54
------------------	----

The sheet(s) containing the abstract is/are attached.

If no classification is furnished, Form P.9 should accompany this form.
The figure of the drawing to which the abstract refers is attached.

(19) World Intellectual Property
Organization
International Bureau



(43) International Publication Date
26 August 2004 (26.08.2004)

PCT

(10) International Publication Number
WO 2004/071539 A3

- (51) International Patent Classification⁷: A61F 13/15
- (21) International Application Number:
PCT/US2004/004349
- (22) International Filing Date: 12 February 2004 (12.02.2004)
- (25) Filing Language: English
- (26) Publication Language: English
- (30) Priority Data:
03002678.5 12 February 2003 (12.02.2003) EP
- (71) Applicant (for all designated States except US): **THE PROCTER & GAMBLE COMPANY** [US/US]; One Procter & Gamble Plaza, Cincinnati, Ohio 45202 (US).
- (72) Inventors; and
- (75) Inventors/Applicants (for US only): **BUSAM, Ludwig** [DE/DE]; Talstrasse 17, 65510 Hunstetten (DE). **BECKER, Uwe, Jurgen** [DE/DE]; Josef-Gebertz-Str. 4, 53881 Euskirchen (DE). **DIVO, Michael** [DE/DE]; Feldbergstr. 14, 61381 Friedrichsdorf (DE). **EHRNSPERGER, Bruno, Johannes** [DE/DE]; Bonner Strasse 5, 65812 Bad Soden (DE).
- (74) Common Representative: **THE PROCTER & GAMBLE COMPANY**; c/o T. David Reed, 6110 Center Hill Road, Cincinnati, OH 45224 (US).
- (81) Designated States (unless otherwise indicated, for every kind of national protection available): AE, AG, AL, AM, AT, AU, AZ, BA, BB, BG, BR, BW, BY, BZ, CA, CH, CN, CO, CR, CU, CZ, DE, DK, DM, DZ, EC, EE, EG, ES, FI, GB, GD, GE, GH, GM, HR, HU, ID, IL, IN, IS, JP, KE, KG, KP, KR, KZ, LC, LK, LR, LS, LT, LU, LV, MA, MD, MG, MK, MN, MW, MX, MZ, NA, NI, NO, NZ, OM, PG, PH, PL, PT, RO, RU, SC, SD, SE, SG, SK, SL, SY, TJ, TM, TN, TR, TT, TZ, UA, UG, US, UZ, VC, VN, YU, ZA, ZM, ZW.
- (84) Designated States (unless otherwise indicated, for every kind of regional protection available): ARIPO (BW, GH, GM, KE, LS, MW, MZ, SD, SL, SZ, TZ, UG, ZM, ZW), Eurasian (AM, AZ, BY, KG, KZ, MD, RU, TJ, TM), European (AT, BE, BG, CH, CY, CZ, DE, DK, EE, ES, FI, FR,

[Continued on next page]

(54) Title: THIN AND DRY DIAPER

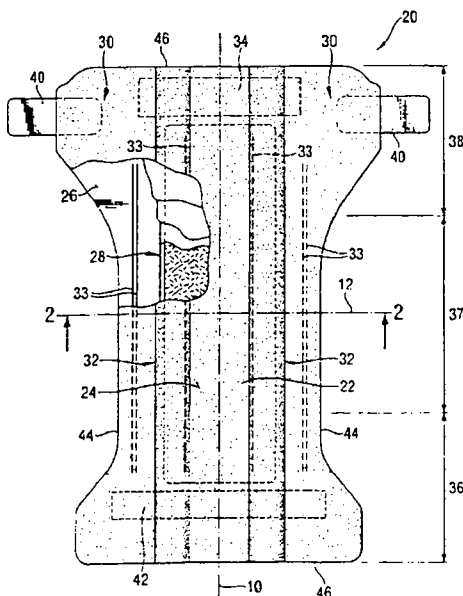

(57) Abstract: The present invention concerns an absorbent article, preferably a disposable absorbent article, such as a diaper. An absorbent core useful for an absorbent article is disclosed which imparts increased wearing comfort to the article and makes it thin and dry. Further disclosed is a process for obtaining such a core. Specifically disclosed is an absorbent core useful for an absorbent article comprising a substrate layer, the substrate layer comprising a first surface and a second surface, the absorbent core further comprising a discontinuous layer of absorbent material, the absorbent material comprising an absorbent polymer material, the absorbent material optionally comprising an absorbent fibrous material and the absorbent fibrous material not representing more than 20 weight percent of the total weight of the absorbent polymer material, the discontinuous layer of absorbent material comprising a first surface and a second surface, the absorbent core further comprising a layer of thermoplastic material, the layer of thermoplastic material comprising a first surface and a second surface and wherein the second surface of the discontinuous layer of absorbent material is in at least partial contact with the first surface of the substrate layer and wherein portions of the second surface of the layer of thermoplastic material are in direct contact with the first surface of the substrate layer and portions of the second surface of the layer of thermoplastic material are in direct contact with the first surface of the discontinuous layer of absorbent material. Further disclosed is a process for providing a storage layer for

an absorbent core useful in an absorbent article, the process comprising the steps of: - providing a substrate material comprising a first surface and a second surface - depositing absorbent material onto the first surface of the substrate material in a pattern, the pattern comprising at least one zone which is substantially free of absorbent material, and the pattern comprising at least one zone comprising absorbent material - depositing a thermoplastic material onto the first surface of the substrate material and the absorbent material, such that portions of the thermoplastic material are in direct contact with the first surface of the substrate and portions of the thermoplastic material are in direct contact with the absorbent material.

Thin and dry diaper

Field of the invention

The present invention concerns an absorbent article, preferably a disposable absorbent article, such as a diaper. The present invention specifically concerns an absorbent core for such an absorbent article that provides an improved immobilization of absorbent polymer material when the article is fully or partially urine loaded. This absorbent core is useful for providing an absorbent article of increased wearing comfort, which is thin and dry.

Background

Absorbent articles, such as diapers and adult incontinence products are well known articles of staple manufacturing. Multiple attempts have been made to provide them with an overall good fit and with a high absorbent capacity. Modern diapers make use of absorbent polymer materials or so-called superabsorbent materials, which allow to store an amount as high as 300 ml of liquid in a typical baby diaper.

While such a diaper is generally a disposable product it is in some instances worn over many hours and worn in a dry state as well as in a urine loaded state.

Hence, to provide good wearing comfort it is very important to keep the absorbent materials comprised by a diaper or other absorbent article in their intended position, both when the article is dry and when the article is fully or partially loaded with urine (or other bodily liquids).

US 4 381 783 (Elias) discloses an absorbent article with a core comprising pockets of absorbent hydrocolloid material. These pockets are provided as to confine the movement of the hydrocolloid material, in particular when the article is fully or partially loaded with urine. The pockets form part of an absorbent layer and are typically provided from cellulose material. Hence, as to achieve good immobilization of the hydrocolloid material according to the teaching of this patent relatively high amount of cellulosic material is required. Moreover, the provision of such pockets may hinder the free distribution of

liquid to the more absorbent areas of the core, for example the areas of hydrocolloid materials.

WO 95/17868 (Palumbo) discloses an absorbent structure comprising two fibre layers and an intermediate layer. This intermediate layer comprises an absorbent hydrogel material in an amount exceeding 120 g/m² and particles of a thermoplastic material. While this construction certainly provides good immobilisation of the absorbent hydrogel particles in the dry state, it seems that only a lesser immobilisation can be achieved in the urine loaded state. The disclosed thermoplastic materials appear to swell much less than the disclosed hydrogel materials. Therefore, in particular when the absorbent structure is to be used in a product to absorb high amounts of liquids, for example a diaper, the wet immobilisation may not be fully satisfactory.

EP 724418 (Tanzer) discloses an absorbent article which includes superabsorbent material located in discrete pockets. The absorbent article comprises a first and a second carrier layer and water-sensitive attaching means for securing together the carrier layers and to provide a plurality of pocket regions. The article comprises high-absorbency material located within said pocket regions. The water-sensitive attachment means provides a wet strength which is less than a separating force imparted by a swelling of that high-absorbency material when that high-absorbency material is exposed to an aqueous liquid. The absorbent article is said to provide an absorbent structure which more securely locates and contains the high-absorbency material in a selected way of pockets when the article is dry. However, due to the construction of the pockets, and specifically due to the selection of the water-sensitive attachment means, these pockets are not maintained when the article is fully or partially loaded with liquids. Therefore, it is believed that this absorbent article does not provide a very satisfactory immobilization of the absorbent material in the fully or partially urine loaded state.

Summary

The present invention concerns an absorbent article, preferably a disposable absorbent article, such as a diaper. An absorbent core useful for an absorbent article is disclosed which imparts increased wearing comfort to the article and makes it thin and dry. Further disclosed is a process for obtaining such a core. Specifically disclosed is an absorbent

core useful for an absorbent article comprising a substrate layer, the substrate layer comprising a first surface and a second surface, the absorbent core further comprising a discontinuous layer of absorbent material, the absorbent material comprising an absorbent polymer material, the absorbent material optionally comprising an absorbent fibrous material and the absorbent fibrous material not representing more than 20 weight percent of the total weight of the absorbent polymer material, the discontinuous layer of absorbent material comprising a first surface and a second surface, the absorbent core further comprising a layer of thermoplastic material, the layer of thermoplastic material comprising a first surface and a second surface and wherein the second surface of the discontinuous layer of absorbent material is in at least partial contact with the first surface of the subject layer and wherein portions of the second surface of the layer of thermoplastic material are in direct contact with the first surface of the substrate layer and portions of the second surface of the layer of thermoplastic material are in direct contact with the first surface of the discontinuous layer of absorbent material.

Further disclosed is a process for providing a storage layer for an absorbent core useful in an absorbent article, the process comprising the steps of:

- providing a substrate material comprising a first surface and a second surface
- depositing absorbent material onto the first surface of the substrate material in a pattern, the pattern comprising at least one zone which is substantially free of absorbent material, and the pattern comprising at least one zone comprising absorbent material
- depositing a thermoplastic material onto the first surface of the substrate material and the absorbent material, such that portions of the thermoplastic material are in direct contact with the first surface of the substrate and portions of the thermoplastic material are in direct contact with the absorbent material.

Detailed Description

The present invention concerns an absorbent article, preferably a disposable absorbent article, such as a diaper.

As used herein, the following terms have the following meanings:

"Absorbent article" refers to devices that absorb and contain liquid, and more

specifically, refers to devices that are placed against or in proximity to the body of the wearer to absorb and contain the various exudates discharged from the body. Absorbent articles include but are not limited to diapers, adult incontinence briefs, training pants, diaper holders and liners, sanitary napkins and the like.

"Disposable" is used herein to describe articles that are generally not intended to be laundered or otherwise restored or reused (i.e., they are intended to be discarded after a single use and, preferably, to be recycled, composted or otherwise disposed of in an environmentally compatible manner).

"Diaper" refers to an absorbent article generally worn by infants and incontinent persons about the lower torso.

"Comprise," "comprising," and "comprises" is an open ended term that specifies the presence of what follows e.g. a component but does not preclude the presents of other features, elements, steps or components known in the art, or disclosed herein.

Figure 1 is a plan view of a diaper 20 as a preferred embodiment of an absorbent article according to the present invention. The diaper is shown in its flat out, uncontracted state (i.e., without elastic induced contraction). Portions of the structure are cut away to more clearly show the underlying structure of the diaper 20. The portion of the diaper 20 that contacts a wearer is facing the viewer. The chassis 22 of the diaper 20 in Figure 1 comprises the main body of the diaper 20. The chassis 22 comprises an outer covering including a liquid pervious topsheet 24 and/or a liquid impervious backsheet 26. The chassis may include a portion of an absorbent core 28 encased between the topsheet 24 and the backsheet 26. The chassis may also include most or all of the absorbent core 28 encased between the topsheet 24 and the backsheet 26. The chassis preferably further includes side panels 30, elasticized leg cuffs 32, and elastic waist feature 34, the leg cuffs 32 and the elastic waist feature each typically comprise elastic members 33. One end portion of the diaper 20 is configured as a first waist region 36 of the diaper 20. The opposite end portion is configured as a second waist region 38 of the diaper 20. An intermediate portion of the diaper 20 is configured as a crotch region 37, which extends longitudinally between the first and second waist regions 36 and 38. The waist regions 36 and 38 may include elastic elements such that they gather about the waist of the wearer to provide improved fit and containment (elastic waist feature 34). The crotch

region 37 is that portion of the diaper 20 which, when the diaper 20 is worn, is generally positioned between the wearer's legs. The diaper 20 is depicted with its longitudinal axis 10 and its transverse axis 12. The periphery of the diaper 20 is defined by the outer edges of the diaper 20 in which the longitudinal edges 44 run generally parallel to the longitudinal axis 100 of the diaper 20 and the end edges 46 run between the longitudinal edges 44 generally parallel to the transverse axis 110 of the diaper 20. The chassis also comprises a fastening system, which may include at least one fastening member 42 and at least one stored landing zone 45.

For unitary absorbent articles, the chassis 22 comprises the main structure of the diaper with other features added to form the composite diaper structure. While the topsheet 24, the backsheet 26, and the absorbent core 28 may be assembled in a variety of well-known configurations, preferred diaper configurations are described generally in U.S. Pat. No. 5,554,145 entitled "Absorbent Article With Multiple Zone Structural Elastic-Like Film Web Extensible Waist Feature" issued to Roe et al. on September 10, 1996; U.S. Pat. No. 5,569,234 entitled "Disposable Pull-On Pant" issued to Buell et al. on October 29, 1996; and U.S. Patent No. 6,004,306 entitled "Absorbent Article With Multi-Directional Extensible Side Panels" issued to Robles et al. on December 21, 1999.

The topsheet 24 in Figure 1 may be fully or partially elasticized or may be foreshortened to provide a void space between the topsheet 24 and the absorbent core 28. Exemplary structures including elasticized or foreshortened topsheets are described in more detail in U.S. Pat. No. 5,037,416 entitled "Disposable Absorbent Article Having Elastically Extensible Topsheet" issued to Allen et al. on August 6, 1991; and U.S. Pat. No. 5,269,775 entitled "Trisection Topsheets for Disposable Absorbent Articles and Disposable Absorbent Articles Having Such Trisection Topsheets" issued to Freeland et al. on December 14, 1993.

The absorbent core 28 in Figure 1 generally is disposed between the topsheet 24 and the backsheet 26. The absorbent core 28 may comprise any absorbent material that is generally compressible, conformable, non-irritating to the wearer's skin, and capable of absorbing and retaining liquids such as urine and other certain body exudates. The absorbent core 28 may comprise a wide variety of liquid-absorbent materials commonly used in disposable diapers and other absorbent articles such as comminuted wood pulp, which is generally referred to as air felt. Examples of other suitable absorbent materials

include creped cellulose wadding; melt blown polymers, including co-form; chemically stiffened, modified or cross-linked cellulosic fibers; tissue, including tissue wraps and tissue laminates; absorbent foams; absorbent sponges; superabsorbent polymers; absorbent gelling materials; or any other known absorbent material or combinations of materials. The absorbent core 28 may further comprise minor amounts (typically less than 10 %) of non-liquid absorbent materials, such as adhesives, waxes, oils and the like.

Exemplary absorbent structures for use as the absorbent assemblies are described in U.S. Patent 4,610,678 (Weisman et al.); U.S. Patent 4,834,735 (Alemany et al.); U.S. Patent 4,888,231 (Angstadt); U.S. Patent No. 5,260,345 (DesMarais et al.); U.S. Patent No. 5,387,207 (Dyer et al.); U.S. Pat. No. 5,397,316 (LaVon et al.); and U.S. Patent No. 5,625,222 (DesMarais et al.).

The backsheet 26 may be joined with the topsheet 24. The backsheet 26 prevents the exudates absorbed by the absorbent core 28 and contained within the article 20 from soiling other external articles that may contact the diaper 20, such as bed sheets and undergarments. In preferred embodiments, the backsheet 26 is substantially impervious to liquids (e.g., urine) and comprises a laminate of a nonwoven and a thin plastic film such as a thermoplastic film having a thickness of about 0.012 mm (0.5 mil) to about 0.051 mm (2.0 mils). Suitable backsheet films include those manufactured by Tredegar Industries Inc. of Terre Haute, IN and sold under the trade names X15306, X10962, and X10964. Other suitable backsheet materials may include breathable materials that permit vapors to escape from the diaper 20 while still preventing exudates from passing through the backsheet 26. Exemplary breathable materials may include materials such as woven webs, nonwoven webs, composite materials such as film-coated nonwoven webs, and microporous films such as manufactured by Mitsui Toatsu Co., of Japan under the designation ESPOIR NO and by EXXON Chemical Co., of Bay City, TX, under the designation EXXAIRE. Suitable breathable composite materials comprising polymer blends are available from Clopay Corporation, Cincinnati, OH under the name HYTREL blend P18-3097. Such breathable composite materials are described in greater detail in PCT Application No. WO 95/16746, published on June 22, 1995 in the name of E. I. DuPont. Other breathable backsheets including nonwoven webs and apertured formed films are described in U.S. Patent No. 5,571,096 issued to Dobrin et al. on November 5, 1996.

The diaper 20 may also include such other features as are known in the art including front and rear ear panels, waist cap features, elastics and the like to provide better fit, containment and aesthetic characteristics. Such additional features are well known in the art and are e.g. described in U.S. Pat. No. 3,860,003 and U.S. Patent No. 5,151,092.

In order to keep the diaper 20 in place about the wearer, preferably at least a portion of the first waist region 36 is attached by the fastening member 42 to at least a portion of the second waist region 38, preferably to form leg opening(s) and an article waist. When fastened, the fastening system carries a tensile load around the article waist. The fastening system is designed to allow an article user to hold one element of the fastening system such as the fastening member 42, and connect the first waist region 36 to the second waist region 38 in at least two places. This is achieved through manipulation of bond strengths between the fastening device elements.

Diapers 20 according to the present invention may be provided with a re-closable fastening system or may alternatively provided in the form of pant-type diapers.

The fastening system and any component thereof may include any material suitable for such a use, including but not limited to plastics, films, foams, nonwoven webs, woven webs, paper, laminates, fiber reinforced plastics and the like, or combinations thereof. It may be preferable that the materials making up the fastening device be flexible. The flexibility is designed to allow the fastening system to conform to the shape of the body and thus, reduces the likelihood that the fastening system will irritate or injure the wearer's skin.

Figure 2 shows a cross section of Figure 1 taken in the transverse axis 110. Starting from the wearer facing side the diaper comprises the topsheet 24, the components of the absorbent core 28, and the backsheet 26. The absorbent core preferably comprises the acquisition system 50, which comprises an upper acquisition layer 52 facing the towards the wearer's skin and an lower acquisition 54 layer facing the garment of the wearer. In one preferred embodiment the upper acquisition layer 52 comprises a non-woven whereas the lower acquisition layer preferably comprises a mixture of chemically stiffened, twisted and curled fibers, high surface area fibers and thermoplastic binding fibers. In another preferred embodiment both acquisition layers are provided from a non-

woven material, which is preferably hydrophilic. The acquisition layer preferably is in direct contact with the storage layer 60.

The storage layer 60 may be wrapped by a core wrap material. In one preferred embodiment the core wrap material comprises a top layer 56 and a bottom layer 58. The core wrap material, the top layer 56 or the bottom layer 58 can be provided from a non-woven material. One preferred material is a so called SMS material, comprising a spunbonded, a melt-blown and a further spunbonded layer. Highly preferred are permanently hydrophilic non-wovens, and in particular nonwovens with durably hydrophilic coatings. An alternative preferred material comprises a SMMS-structure.

The top layer 56 and the bottom layer 58 may be provided from two or more separate sheets of materials or they may be alternatively provided from a unitary sheet of material. Such a unitary sheet of material may be wrapped around the storage layer 60 e.g. in a C-fold.

Preferred non-woven materials are provided from synthetic fibers, such as PE, PET and most preferably PP. As the polymers used for nonwoven production are inherently hydrophobic, they are preferably coated with hydrophilic coatings.

A preferred way to produce nonwovens with durably hydrophilic coatings, is via applying a hydrophilic monomer and a radical polymerization initiator onto the nonwoven, and conducting a polymerization activated via UV light resulting in monomer chemically bound to the surface of the nonwoven as described in co-pending European patent application EP 02021943.2 (attorney's docket no. CM2701FQ).

An alternative preferred way to produce nonwovens with durably hydrophilic coatings is to coat the nonwoven with hydrophilic nanoparticles as described in co-pending application WO 02/064877.

Typically, nanoparticles have a largest dimension of below 750 nm. Nanoparticles with sizes ranging from 2 to 750 nm can be economically produced. The advantages of nanoparticles is that many of them can be easily dispersed in water solution to enable

coating application onto the nonwoven; they typically form transparent coatings, and the coatings applied from water solutions are typically sufficiently durable to exposure to water.

Nanoparticles can be organic or inorganic, synthetic or natural. Inorganic nanoparticles generally exist as oxides, silicates, carbonates. Typical examples of suitable nanoparticles are layered clay minerals (e.g. LAPONITE™ from Southern Clay Products, Inc. (USA), and Boehmite alumina (e.g. Disperal P2™ from North American Sasol. Inc.)

A highly preferred nanoparticle coated non-woven is disclosed in the co-pending patent application entitled "Disposable absorbent article comprising a durable hydrophilic core wrap" the inventors (in the US the applicants) of which are Ekaterina Anatolyevna Ponomarenko and Mattias NMN Schmidt.

Further useful non-wovens are described in co-pending patent applications with attorney docket nos. 8837,8838, 8408MX, 8857 and 8858.

In some cases, the nonwoven surface can be pre-treated with high energy treatment (corona, plasma) prior to application of nanoparticle coatings. High energy pre-treatment typically temporarily increases the surface energy of a low surface energy surface (such as PP) and thus enables better wetting of a nonwoven by the nanoparticle dispersion in water.

Notably, permanently hydrophilic non-wovens are also useful in other parts of an absorbent article. For example, topsheets and acquisition layers comprising permanently hydrophilic non-wovens as described above have been found to work well.

In summary, in one aspect of the present invention, absorbent articles are preferred which comprise a nonwoven fabric, the nonwoven fabric comprising a plurality of fibers and having a surface tension of at least 55, preferably at least 60 and most preferably at least 65 mN/m or higher when being wetted with saline solution and has a liquid strike through time of less than 5 s for a fifth gush of liquid.

The surface tension is a measure of how permanently a certain hydrophilicity level is achieved. The value is to be measured using the test method described hereinbelow.

The liquid strike through time is a measure of a certain hydrophilicity level. The value is to be measured using the test method described hereinbelow.

In a preferred embodiment of the present invention the absorbent core 28 comprises a substrate layer 100, absorbent polymer material 110 and a fibrous layer of adhesive 120. The substrate layer 100 is preferably provided from a non-woven material, preferred non-wovens are those exemplified above for the top layer 56 or the bottom layer 58.

The substrate layer 100 comprises a first surface and a second surface. At least portions of the first surface of the substrate layer 100 are in direct contact with a layer of absorbent polymer material 110. This layer of absorbent polymer material 110 is preferably a discontinuous layer, and comprises a first surface and a second surface. As used herein, a discontinuous layer is a layer comprising openings. Typically these openings have a diameter or largest span of less than 10 mm, preferably less than 5 mm, 3 mm, 2 mm and of more than 0.5 mm, 1 mm or 1.5 mm. At least portions of the second surface of the absorbent polymer material layer 110 are in contact with at least portions of the first surface of the substrate layer material 100. The first surface of the absorbent polymer material 110 defines a certain height of the layer of absorbent polymer above the first surface of the layer of substrate material 100. When the absorbent polymer material layer 110 is provided as a discontinuous layer, portions of the first surface of the substrate layer 100 are not covered by absorbent polymer material 110. The absorbent core 28 further comprises a thermoplastic composition 120. This thermoplastic composition 120 serves to at least partially immobilize the absorbent polymer material 110.

However, in an even more preferred embodiment of the present invention the thermoplastic material 120 is provided as a fibrous layer which is partially in contact with the absorbent polymer material 110 and partially in contact with the substrate layer 100. Figure 3 shows such a preferred structure. In this preferred structure the absorbent polymer material layer 110 is provided as a discontinuous layer, a layer of fibrous thermoplastic material 120 is laid down onto the layer of absorbent polymeric material 110, such that the thermoplastic layer 120 is in direct contact with the first surface of the layer of absorbent polymer material 110, but also in direct contact with the first surface of the substrate layer 100, where the substrate layer is not covered by the absorbent

polymeric material 110. This imparts an essentially three-dimensional structure to the fibrous layer of thermoplastic material 120 which in itself is essentially a two-dimensional structure of relatively small thickness (in z-direction), as compared to the extension in x- and y-direction. In other words, the fibrous thermoplastic material layer 120 undulates between the first surface of the absorbent polymer material 110 and the first surface of the substrate layer 100.

Thereby, the thermoplastic material 120 provides cavities to hold the absorbent polymer material 110, and thereby immobilizes this material. In a further aspect, the thermoplastic material 120 bonds to the substrate 100 and thus affixes the absorbent polymer material 110 to the substrate 100. Highly preferred thermoplastic materials will also penetrate into both the absorbent polymer material 110 and the substrate layer 100, thus providing for further immobilization and affixation.

Of course, while the thermoplastic materials disclosed herein provide a much improved wet immobilisation, i.e. immobilisation of absorbent material when the article is wet or at least partially loaded, these thermoplastic materials also provide a very good immobilisation of absorbent material when the article is dry.

In accordance with the present invention, the absorbent polymer material 110 may also be mixed with fibrous material, such as airfelt material, which can provide a matrix for further immobilization of the super-absorbent polymer material. However, preferably a relatively low amount of fibrous cellulose material is used, preferably less than 40 weight %, 20 or 10 weight % of cellulose fibrous material as compared to the weight of absorbent polymer material 110.

An alternative preferred embodiment of the present invention is shown in Figure 4. The absorbent core shown in figure 4 further comprises a cover layer 130. This cover layer may be provided of the same material as the substrate layer 100, or may be provided from a different material. Preferred materials for the cover layer are the non-woven materials, typically the materials described above as useful for the top layer 56 and the bottom layer 58. In this embodiment portions of the cover layer 130 bond to portions of the substrate layer 100 via the thermoplastic material 120. Thereby, the substrate layer 100 together with the cover layer 130 provides cavities to immobilize the absorbent polymer material 110.

With reference to figure 3 and 4 the areas of direct contact between the thermoplastic material 120 and the substrate material 100 are referred to as areas of junction 140. The shape number and disposition of the areas of junction 140 will influence the immobilization of the absorbent polymer material 110. The areas of junction can be of squared, rectangular or circular shape. Preferred areas of junction are of circular shape. Preferably, they have a diameter of more than 0.5 mm, or 1 mm, or 1.5 mm and of less than 10 mm, or 5 mm, or 3 mm, or 2 mm. If the areas of junction 140 are not of circular shape, they preferably are of a size as to fit inside a circle of any of the preferred diameters given above.

The areas of junction 140 can be disposed in a regular or irregular pattern. For example, the areas of junction 140 may be disposed along lines as shown in Figure 5. These lines may be aligned with the longitudinal axis of the absorbent core, or alternatively they may have a certain angle in respect to the longitudinal edges of the core. It has been found, that a disposition along lines parallel with the longitudinal edges of the absorbent core 28 create channels in the longitudinal direction which lead to a lesser wet immobilization. Preferably, therefore the areas of junction 140 are arranged along lines which form an angle of 20 degree, 30 degree, 40 degree, or 45 degree with the longitudinal edges of the absorbent core 28. Another preferred pattern for the areas of junction 140 is a pattern comprising polygons, for example pentagons and hexagons or a combination of pentagons and hexagons. Also preferred are irregular patterns of areas of junction 140, which also have been found to give a good wet immobilization.

Two fundamentally different patterns of areas of junctions 140 can be chosen in accordance with the present invention. In one embodiment the areas of junctions are discrete. They are positioned within the areas of absorbent material, like islands in a sea. The areas of absorbent materials are then referred to as connected areas. In an alternative embodiment, the areas of junctions can be connected. Then, the absorbent material can be deposited in a discrete pattern, or in other words the absorbent material represents islands in a sea of thermoplastic material (120). Hence, a discontinuous layer of absorbent polymer material 110 may comprise connected areas of absorbent polymer material 110 or may comprise discrete areas of absorbent polymer material 110.

In a further aspect of the present invention, it has been found that absorbent cores providing for a good wet immobilization can be formed by combining two layers as shown in Figure 3 and as described in the context thereof. Such an embodiment is shown in Figure 6. The absorbent core material shown in Figure 6 comprises two substrate layers 100, two layers of absorbent polymer material 110 and two layers of fibrous thermoplastic materials 120. When two discontinuous layers of an absorbent polymer material 110 are used, they would be typically arranged in such a way that the absorbent polymer material of the one layer faces the areas of junction 140 of the other layer. In an alternative preferred embodiment, however, the areas of junction (140) are offset and do not face each other. Hence preferably, when two storage layers are joined, this is done such that the first surface of the substrate layer (100) of the first storage layer (60) faces the first surface of the substrate layer (100) of the second storage layer (60).

The present invention, and specifically the preferred embodiment described with reference to Figure 3, 4 and 6 can be used to provide the storage layer 60 of an absorbent core. However, they can also be used to provide the full absorbent core 28. In that case, no further materials wrapping the core, such as the top layer 56 and the bottom layer 58 are being used. With reference to the embodiment of Figure 3 the substrate layer 100 may provide the function of the bottom layer 58 and the layer of fibrous thermoplastic material 120 may provide the function of the top layer 56. With reference to Figure 4 the cover layer 130 may provide the function of the top layer 56 and the substrate layer 100 may provide the function of the bottom layer 58. With reference to Figure 6, the two substrate layers 100 used may provide the functions of the top layer 56 and the bottom layer 58, respectively.

According to the present invention the thermoplastic layer 120 can comprise any thermoplastic composition, preferred are adhesive thermoplastic compositions, also referred to as hot melt adhesives. A variety of thermoplastic compositions are suitable to immobilize absorbent material.

Some initially thermoplastic materials may later lose their thermoplasticity due to a curing step, e.g. initiated via heat, UV radiation, electron beam exposure or moisture or other means of curing, leading to the irreversible formation of a crosslinked network of

covalent bonds. Those materials having lost their initial thermoplastic behaviour are herein also understood as thermoplastic materials 120.

Without wishing to be bound by theory it has been found that those thermoplastic compositions are most useful for immobilizing the absorbent polymer material 110, which combine good cohesion and good adhesion behaviour. Good adhesion is critical to ensure that the thermoplastic layer 120 maintains good contact with the absorbent polymer material 110 and in particular with the substrate (100). Good adhesion is a challenge, namely when a non-woven substrate is used. Good cohesion ensures that the adhesive does not break, in particular in response to external forces, and namely in response to strain. The adhesive is subject to external forces when the absorbent product has acquired liquid, which is then stored in the absorbent polymer material 110 which in response swells. A preferred adhesive will allow for such swelling, without breaking and without imparting too many compressive forces, which would restrain the absorbent polymer material 110 from swelling. Importantly, in accordance with the present invention the adhesive should not break, which would deteriorate the wet immobilization. Preferred thermoplastic compositions meeting these requirements have the following features:

The thermoplastic composition may comprise, in its entirety, a single thermoplastic polymer or a blend of thermoplastic polymers, having a softening point, as determined by the ASTM Method D-36-95 "Ring and Ball", in the range between 50 °C and 300 °C, or alternatively the thermoplastic composition may be a hot melt adhesive comprising at least one thermoplastic polymer in combination with other thermoplastic diluents such as tackifying resins, plasticizers and additives such as antioxidants.

The thermoplastic polymer has typically a molecular weight (Mw) of more than 10,000 and a glass transition temperature (T_g) usually below room temperature. Typical concentrations of the polymer in a hot melt are in the range of 20 - 40 % by weight. A wide variety of thermoplastic polymers are suitable for use in the present invention. Such thermoplastic polymers are preferably water insensitive. Exemplary polymers are (styrenic) block copolymers including A-B-A triblock structures, A-B diblock structures and (A-B)_n radial block copolymer structures wherein the A blocks are non-elastomeric polymer blocks, typically comprising polystyrene, and the B blocks are unsaturated conjugated diene or (partly) hydrogenated versions of such. The B block is typically

isoprene, butadiene, ethylene/butylene (hydrogenated butadiene), ethylene/propylene (hydrogenated isoprene), and mixtures thereof.

Other suitable thermoplastic polymers that may be employed are metallocene polyolefins, which are ethylene polymers prepared using single-site or metallocene catalysts. Therein, at least one comonomer can be polymerized with ethylene to make a copolymer, terpolymer or higher order polymer. Also applicable are amorphous polyolefins or amorphous polyalphaolefins (APAO) which are homopolymers, copolymers or terpolymers of C2 to C8 alphaolefins.

The resin has typically a Mw below 5,000 and a Tg usually above room temperature, typical concentrations of the resin in a hot melt are in the range of 30 - 60 %. The plasticizer has a low Mw of typically less than 1,000 and a Tg below room temperature, a typical concentration is 0 -15%.

Preferably the adhesive is present in the forms of fibres throughout the core, i.e. the adhesive is fiberized. Preferably, the fibres will have an average thickness of 1 – 50 micrometer and an average length of 5 mm to 50 cm.

To improve the adhesion of the thermoplastic material 120 to the substrate layer 100 or to any other layer, in particular any other non-woven layer, such layers may be pre-treated with an auxiliary adhesive.

Preferably, the adhesive will meet at least one, and more preferably several or all of the following parameters:

A preferred adhesive will have a storage modulus G' measured at 20°C of at least 30.000 Pa and less than 300.000 Pa preferably less than 200.000 Pa, more preferably less than 100.000 Pa. The storage modulus G' at 20°C is a measure for the permanent "tackiness" or permanent adhesion of the thermoplastic material used. Good adhesion will ensure a good and permanent contact between the thermoplastic material and for example the substrate layer 100. In a further aspect, the storage modulus G' measured at 60°C should be less than 300.000 Pa and more than 18.000 Pa, preferably more than 24.000 Pa, most preferably more than 30.000. The storage modulus measured at 60°C

is a measure for the form stability of the thermoplastic material at elevated ambient temperatures. This value is particularly important if the absorbent product is used in a hot climate where the thermoplastic composition would lose its integrity if the storage modulus G' at 60°C is not sufficiently high.

In a further aspect, the loss angle $\tan \Delta$ of the adhesive at 60°C should be below the value of 1, preferably below the value of 0.5. The loss angle $\tan \Delta$ at 60°C is correlated with the liquid character of an adhesive at elevated ambient temperatures. The lower $\tan \Delta$, the more an adhesive behaves like a solid rather than a liquid, i.e. the lower its tendency to flow or to migrate and the lower the tendency of an adhesive superstructure as described herein to deteriorate or even to collapse over time. This value is hence particularly important if the absorbent article is used in a hot climate.

In a further aspect, the preferred adhesive should have a glass transition temperature T_g of less than 25°C, preferably less than 22°C, more preferably less than 18°C, and most preferably less than 15°C. A low glass transition temperature T_g is beneficial for good adhesion. In a further aspect a low glass transition temperature T_g ensures that the adhesive thermoplastic material does not become too brittle.

In yet a further aspect, a preferred adhesive will have a sufficiently high cross-over temperature T_x . A sufficiently high cross-over temperature T_x has been found beneficial for high temperature stability of the thermoplastic layer and hence it ensures good performance of the absorbent product and in particular good wet immobilization even under conditions of hot climates and high temperatures. Therefore, T_x should preferably be above 80°C, more preferably above 85°C, and most preferably above 90°C.

In a further important aspect, preferred adhesives in accordance with the present invention will have a sufficient cohesive strength parameter γ . The cohesive strength parameter γ is measured using the rheological creep test as described hereinafter. A sufficiently low cohesive strength parameter γ is representative of elastic adhesive which, for example, can be stretched without tearing. If a stress of $\tau = 1000$ Pa is applied, the cohesive strength parameter γ is preferably less than 100 %, more preferably less than 90 %, and most preferably less than 75 %. For a stress of $\tau = 125\,000$ Pa, the cohesive

strength parameter γ is preferably less than 1200 %, more preferably less than 1000 %, and most preferably less than 800 %.

A highly preferred adhesive useful as a thermoplastic material (120) as described herein will meet most or all of the above parameters. Specific care must be taken to ensure that the adhesive provides good cohesion and good adhesion at the same time.

The process for producing preferred absorbent cores 28 in accordance with the present invention comprises the following steps:

The absorbent core 28 is laid down onto a laydown drum, which presents an uneven surface. In a first process step the substrate layer 100 is laid on to the uneven surface. Due to gravity, or preferably by using a vacuum means, the substrate layer material will follow the contours of the uneven surface and thereby the substrate layer material will assume a mountain and valley shape. Onto this substrate layer (100) absorbent polymeric material is disposed by means known in the art. The absorbent polymer material will accumulate in the valleys presented by the substrate layer 100. In a further process step a hot melt adhesive is placed onto the absorbent polymer material.

While any adhesive application means known in the art can be used to place the hot melt adhesive on to the absorbent polymer material, the hot melt adhesive is preferably applied by a nozzle system. Preferably, a nozzle system is utilised, which can provide a relatively thin but wide curtain of adhesive. This curtain of adhesive is then placed onto the substrate layer 100 and the absorbent polymer material. As the mountain tops of the substrate layer 100 are less covered by absorbent polymer material the adhesive will make contact with these areas of the substrate layer.

In an optional further process step a cover layer 130 is placed upon the substrate layer 100, the absorbent polymer material and the hot melt adhesive layer. The cover layer 130 will be in adhesive contact with the substrate layer 100 in the areas of junction 140. In these areas of junction 140 the adhesive is in direct contact with the substrate layer 100. The cover layer 130 will typically not be in adhesive contact with the substrate layer 100 where the valleys of the substrate layer 100 are filled with absorbent polymer material.

Alternatively the cover layer 130 can be laid down onto a drum with an uneven surface and the substrate layer 100 can be added in a consecutive process step. The embodiment shown in Fig. 4 could be produced by such a process.

In one alternative embodiment, the cover layer 130 and the substrate layer 100 are provided from a unitary sheet of material. The placing of the cover layer 130 onto the substrate layer 100 will then involve the folding of the unitary piece of material.

Hence, the uneven surface of the lay-down system, which preferably is a lay-down drum, typically determines the distribution of absorbent polymeric material throughout the storage layer 60 and likewise determines the pattern of areas of junction 140. Alternatively, the distribution of absorbent polymeric material may be influenced by vacuum means.

Preferably the distribution of absorbent polymeric material is profiled and most preferably profiled in the longitudinal direction. Hence, along the longitudinal axis of the absorbent core, which is normally coincident with the longitudinal axis of the absorbent article, for example of the diaper, the basis weight of the absorbent polymer material will change. Preferably the basis weight of absorbent polymer material in at least one freely selected first square measuring 1 cm x 1 cm is at least 10 %, or 20%, or 30%, 40% or 50% higher than the basis weight of absorbent polymer material in at least one freely selected second square measuring 1 cm x 1 cm. Preferably the criterion is met if the first and the second square are centred about the longitudinal axis.

Optionally, the absorbent core can also comprise an absorbent fibrous material, for example cellulose fibres. This fibrous material can be pre-mixed with the absorbent polymeric material and be laid down in one process step or it can alternatively be laid-down in separate process steps.

It has been found beneficial to use a particulate absorbent polymer material for absorbent cores made in the present invention. Without wishing to be bound by theory it is believed that such material, even in the swollen state, i.e. when liquid has been absorbed, does not substantially obstruct the liquid flow throughout the material, especially when the permeability as expressed by the saline flow conductivity of the absorbent polymer material is greater than 10, 20, 30 or 40 SFC- units, where 1 SFC unit

is 1×10^{-7} (cm³ x s) / g. Saline flow conductivity is a parameter well recognised in the art and is to be measured in accordance with the test disclosed in EP 752 892 B.

As to achieve a sufficient absorbent capacity in a preferred absorbent article according to the present invention and especially if the absorbent article is a diaper or an adult incontinence product, superabsorbent polymer material will be present with a basis weight of more than 50, 100, 200, 300, 400, 500, 600, 700, 800 or 900 g/m².

Preferred articles according to the present invention achieve a relatively narrow crotch width, which increases the wearing comfort. A preferred article according to the present invention achieves a crotch width of less than 100 mm, 90 mm, 80 mm, 70 mm, 60 mm or even less than 50 mm. Hence, preferably an absorbent core according to the present invention has a crotch width as measured along a transversal line which is positioned at equal distance to the front edge and the rear edge of the core which is of less than 100 mm, 90 mm, 80 mm, 70 mm, 60 mm or even less than 50 mm. It has been found that for most absorbent articles the liquid discharge occurs predominately in the front half. The front half of the absorbent core should therefore comprise most of the absorbent capacity of the core. Preferably the front half of said absorbent core comprises more than 60% of the absorbent capacity, more preferably more than 65%, 70%, 75%, 80%, 85%, or 90%.

All patents and patent applications (including any patents which issue thereon) assigned to the Procter&Gamble Company referred to herein are hereby incorporated by reference to the extent that it is consistent herewith.

Rheological Creep Test

Equipment:

- AR 2000 Rheometer by TA Instruments as described below
- Balance

Rheometer:

A test set up for carrying out the creep test employs the AR 2000 Rheometer by TA Instruments. Other rheometers are available on the market, which yield substantially the same test results. Figure 8 provides a schematic representation of the rheometer (400). The rheometer is capable of applying a shear stress to the adhesive and measuring the resulting strain (shear deformation) response at constant temperature. The adhesive is placed between a Peltier-element acting as lower, fixed plate (410) and an upper plate (420) with a radius R of 10 mm, which is connected to the drive shaft of a motor to generate the shear stress. The gap between both plates has a height H of 1500 micron. The Peltier-element enables to control the temperature of the material ($\pm 0.5^{\circ}\text{C}$).

Sample preparation:

- Homogenize the adhesive at 150°C - 175°C (depending on type of adhesive) for 1 hour in a lab oven
- Stir occasionally to ensure proper mixing of wrap and adhesive, but prevent formation of air bubbles
- After homogenisation in the oven pour the sample on silicone paper for cooling
- After the material is cooled to RT (room temperature), weigh approximately 0.6 g of adhesive for the creep test and place the material on the Peltier-plate

Test execution:

- Melt the adhesive at 120°C (or higher if necessary) on the Peltier-plate
- As soon as the adhesive is completely molten, lower the upper plate to a gap of 1500 micron to bring it into proper contact with the adhesive melt
- Remove excessive material
- Set the temperature to the measurement temperature of 35°C

- Set the conditioning time to 20min to ensure thermal equilibrium between Peltier, adhesive and upper plate
- Set constant measurement stress τ (e.g. 10 000Pa resp. 125 000 Pa) to be applied immediately to the adhesive at the beginning of the retardation step
- Set the retardation time to 5min
- Set the stress to zero for immediate removal of stress at the beginning of the recovery step
- Set the recovery time to 5min
- After the test is completed, melt the adhesive, lift the upper plate and remove the adhesive from both Peltier and upper plate.
- Set the temperature back to the measurement temperature or stand-by temperature (RT)

Result reporting

- Report the strain in % (γ value, herein referred to as cohesive strength parameter) as a function of temperature and stress after 5min application of stress (at the end of the retardation step), e.g. at 35°C and 10,000Pa resp. 35°C and 125 000 PA as described herein.

Dynamical Mechanical Analysis (DMA) – Temperature Sweep

Equipment:

- AR 2000 Rheometer by TA Instruments as described below
- Balance

Rheometer:

A test set up for carrying out the temperature sweep comprises the AR 2000 Rheometer by TA Instruments as described herein. Other rheometers are available on the market, which yield substantially the same test results. Figure 8 provides a schematic representation of the rheometer (400). The rheometer is capable of applying a shear stress to the adhesive and measuring the resulting strain (shear deformation) response at constant temperature.

The rheometer is capable of applying a small oscillatory stress to achieve a constant oscillatory strain within the linear viscoelastic region of the adhesive (e.g. 0.05%). The instrument enables the measurement of resulting Storage Modulus, Loss Modulus and the phase shift between stress and strain (Loss Factor) in dependence of temperature. The oscillation frequency is 1Hz. The adhesive is placed between a Peltier-element acting as lower, fixed plate (410) and an upper plate (420) with a radius R of 10 mm, which is connected to the drive shaft of a motor to generate the shear stress. The gap between both plates has a height H of 1500 micron. The Peltier-element enables to control the temperature of the material ($\pm 0.5^{\circ}\text{C}$).

Sample preparation:

- Homogenize the adhesive at 150°C - 175°C (depending on type of adhesive) for 1 hour in a lab oven.
- Stir occasionally to ensure proper mixing of wrap and adhesive, but prevent formation of air bubbles.
- After homogenisation in the oven pour the sample on silicone paper for cooling.
- After the material is cooled to RT, weigh approximately 0.6g of adhesive the temperature sweep and place the material on the Peltier-plate.

Test execution:

- Melt the adhesive at 120°C (or higher if necessary) on the Peltier-plate
- As soon as the adhesive is completely molten, lower the upper plate to a gap of 1500micron to bring it into proper contact with the adhesive melt
- Remove excessive material and set the temperature to the measurement start temperature (e.g. 150°C , depending on the temperature range of interest → see below)
- Set the temperature to the start temperature depending on the temperature range at which the rheological properties of the adhesive need to be determined (e.g. 150°C , in any case start with highest temperature)
- Set the conditioning time to 20min to ensure thermal equilibrium between Peltier, adhesive and upper plate
- Set the start temperature (see above)
- Set the constant measurement strain (e.g. 0.05%)
- Set the constant frequency (e.g. 1Hz)

- Set the cooling rate (e.g. 2°C/min)
- Set the end temperature (e.g. -5°C) depending on the temperature range at which the rheological properties of the adhesive need to be determined and depending on the cooling capacity of the Peltier
- Set the temperature to RT
- After the test is completed, melt the adhesive, lift the upper plate and remove the adhesive from both Peltier and upper plate.
- Set the temperature back to RT

Result reporting

- Report the Storage Modulus G' in Pa and the Loss Factor $\tan \Delta$ (dimensionless) at 20°C and 60°C
- Report the glass transition temperature T_g in °C (inflection point of G')
 - Report the cross-over temperature T_x in °C at which G' equals G'' at the end of the rubber plateau towards higher temperature (beginning of terminal zone)

Determination of surface tension

The surface tension (unit: mN/m) is determined according to the following test.

Apparatus:

Equipment: K10 tensiometer provided by Krüss GmbH, Germany or equivalent. The vessel elevation speed should be 4 mm/min. Liquid surface height should be sensed automatically when using a plate or a ring. The equipment must be able to adjust the sample position automatically to the correct height. Precision of test should be +/- 0.1 mN/m.

Procedure:

1. Pouring 40 ml of saline (0.9 wt% NaCl in deionized water) into a cleaned beaker.
2. Testing the surface tension with a platinum ring or a platinum plate. The surface tension should be 71-72 mN/m at 20 °C.

3. Cleaning the beaker with deionized water and isopropanol and burning it out with a gas burner for a few seconds. Waiting until equilibrate to room temperature is reached.
4. Placing 10 60x60 mm pieces of test nonwoven into a cleaned beaker. The nonwoven should have a basis weight of at least 10 gsm.
5. Adding 40 ml of saline (0.9 wt% NaCl in deionized water).
6. Stirring with a clean surfactant-free plastic stick for 10 seconds.
7. Letting the solution with nonwoven stand for 5 minutes.
8. Stirring again for 10 seconds.
9. Removing the nonwoven from the solvent with a clean surfactant-free plastic stick.
10. Letting the solution stand for 10 minutes.
11. Testing surface tension with a platinum plate or platinum ring.

Determination of strike through

The test is carried out based on Edana Method 150.3-96 (February 1996) Liquid Strike Through Time. As a major modification compared to the Edana Method, the test described below not only measures the first gush but also several subsequent gushes.

Apparatus

- Lister Strike Through Equipment:
 - Funnel fitted with magnetic valve: Rate of discharge of 25ml in 3,5 (\pm 0.25) seconds
 - Strike through plate: Constructed of 25 mm thick acrylic glass. The total weight of the plate must be 500 g. The electrodes should be of non-corrosive material. The electrodes are set in (4.0 mm x 7.0 mm) cross section grooves, cut in the base of the plate and fixed with quick setting epoxy resin.
 - Base plate: A square of acrylic glass 125 mm x 125 mm approximately.
- Ring stand to support the funnel

- Electronic Timer measuring to 0.01 seconds
- Burette with 50 ml capacity
- Core filter paper Ahlström Grade 989 or equivalent (average Strike Through time 1.7s + - 0.3 s, dimensions: 10 x 10 cm)

Procedure

1. Carefully cutting the required number of samples, 12.5cm x 12.5cm touching the sample only at the edge of the sample.
2. Taking 10 plies of core filter paper.
3. Placing one sample on the set of 10 plies of filter paper on the base plate. The sample should be positioned on the filter paper in such a way that the side of the nonwoven, which is intended to face the user's skin (when applied in an absorbent article) is uppermost.
4. Placing the strike through plate on top with the center of the plate over the center of the test piece.
5. Centering the burette and the funnel over the plate.
6. Ensuring that the electrodes are connected to the timer. Switching on the timer and set the clock to zero.
7. Filling the burette with saline solution (0.9 wt% NaCl in deionized water).
8. Keeping the discharge valve of the funnel closed and run 5.0 ml of liquid (= one gush) from the burette into the funnel.
8. Opening the magnetic valve of the funnel to discharge 5.0 ml of liquid. The initial flow of liquid will complete the electrical circuit and start the timer. It will stop when the liquid has penetrated into the pad and fallen below the level of the electrodes in the strike through plate.
9. Recording the time indicated on the electronic timer.

10. Waiting for 60 seconds and continuing as of point 6 for the second, the third gush and any subsequent gush, with each gush comprising 5 ml of liquid.

11. Report: Time for the 1st, 2nd and any subsequent gush in seconds.

Claims:

1. An absorbent core useful for an absorbent article comprising a substrate layer,
said substrate layer comprising a first surface and a second surface,
said absorbent core further comprising a discontinuous layer of absorbent material,
said absorbent material comprising an absorbent polymer material,
said absorbent material optionally comprising an absorbent fibrous material and
said absorbent fibrous material not representing more than 20 weight percent of the total weight of the absorbent polymer material,
said discontinuous layer of absorbent material comprising a first surface and a second surface,
said absorbent core further comprising a layer of thermoplastic material,
said layer of thermoplastic material comprising a first surface and a second surface

characterized in that

said second surface of said discontinuous layer of absorbent material is in at least partial contact with said first surface of said substrate layer

and in that

portions of said second surface of said layer of thermoplastic material are in direct contact with said first surface of said substrate layer and portions of said second surface of the said layer of thermoplastic material are in direct contact with said first surface of said discontinuous layer of absorbent material.

2. An absorbent core according to claim 1, wherein said thermoplastic material is a hot melt adhesive.

3. An absorbent core according to claim 2, wherein said thermoplastic material is fiberized.
4. An absorbent core according to claims 1, 2 or 3, wherein said layer of thermoplastic material comprises a net-like structure.
5. An absorbent core according to any one of the preceding claims, wherein said absorbent polymer material comprises absorbent polymer particles.
6. An absorbent core according to any one of the preceding claims, wherein said absorbent polymer material is present throughout the area of said absorbent core in a basis weight of at least 100 g/m² and preferably at least 300 g/m².
7. An absorbent core according to any one of the preceding claims, comprising at least two substrate layers.
8. An absorbent core according to any one of the preceding claims comprising at least one substrate layer and at least one cover layer.
9. An absorbent core according to claims 7 or 8, wherein at least one of said substrate layers or at least one of said cover layers comprises a permanently hydrophilic non-woven, and preferably a permanently hydrophilic non-woven having a surface tension of at least 55 mN/m when being wetted with saline solution and having a liquid strike through time of less than 5 s for a fifth gush of liquid.
10. A process for providing a storage layer for an absorbent core useful in an absorbent article, said process comprising the steps of:
 - providing a substrate material comprising a first surface and a second surface;
 - depositing absorbent material onto said first surface of said substrate material in a pattern, the pattern comprising at least one zone which is

substantially free of absorbent material, and the pattern comprising at least one zone comprising absorbent material;

- depositing a thermoplastic material onto said first surface of said substrate material and said absorbent material, such that portions of said thermoplastic material are in direct contact with said first surface of said substrate and portions of said thermoplastic material are in direct contact with said absorbent material.

11. A process according to claim 10, wherein said absorbent material comprises 80 weight percent, preferably 90 weight percent, preferably 100 weight percent of absorbent polymer material.
12. A process according to claim 10 or 11, wherein said zones substantially free of absorbent material are connected.
13. A process according to any one of the preceding claims, wherein said zones comprising absorbent material are connected.
14. A process for providing an absorbent core, said process comprising a step of joining one or more storage layers made in accordance with any one of the preceding claims to provide an absorbent core comprising several storage layers.
15. A process according to claim 14, wherein a first and a second storage layer are joined, such that the first surface of the substrate material of the first storage layer faces the first surface of the substrate layer of the second storage layer.
16. A storage layer for an absorbent core useful in an absorbent article obtainable by a process according to any one of the preceding claims.
17. An absorbent core according to claim 1, substantially as herein described and illustrated.

18. A process according to claim 10, or claim 14, substantially as herein described and illustrated.

19. A storage layer according to claim 16, substantially as herein described and illustrated.

20. A new absorbent core, a new process for providing a storage layer, a new process for providing an absorbent core, or a new storage layer, substantially as herein described.

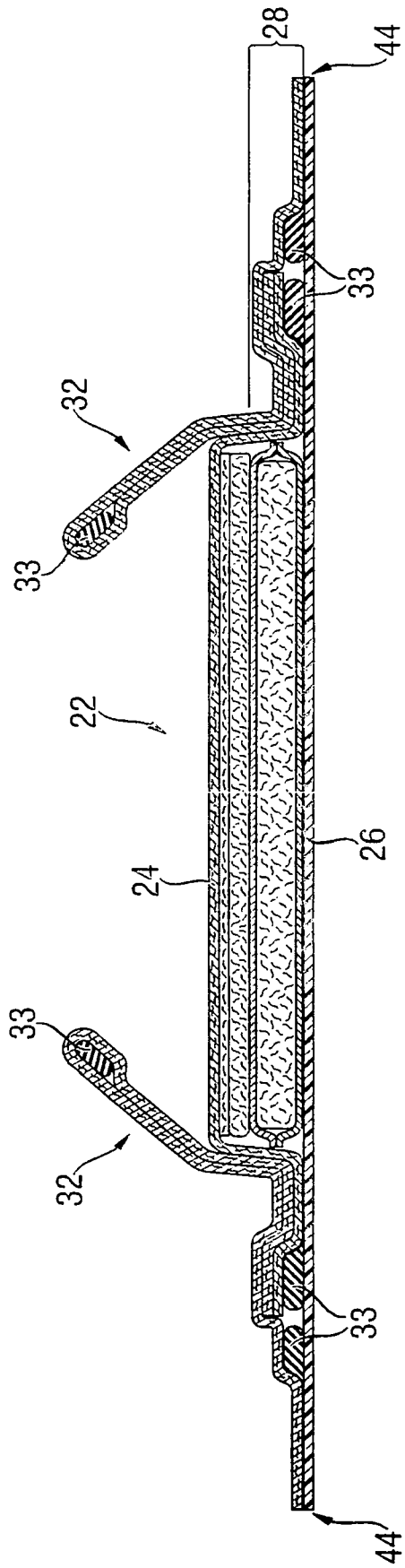

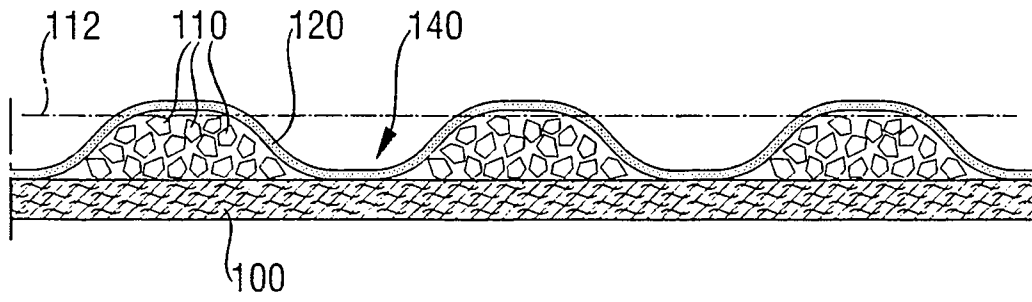

Fig. 3

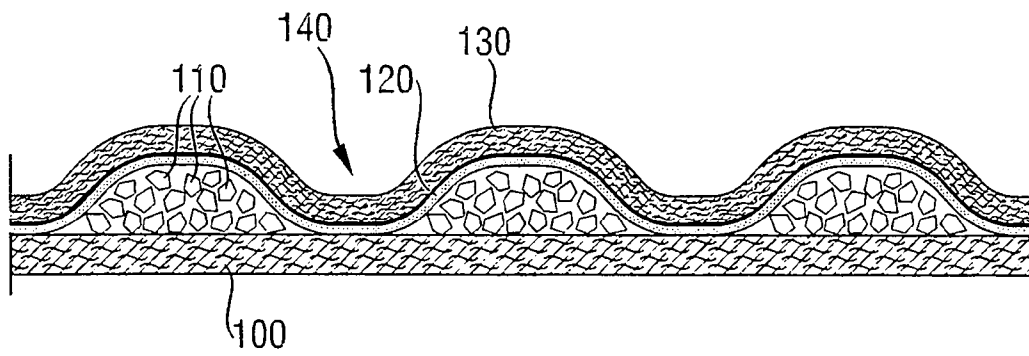
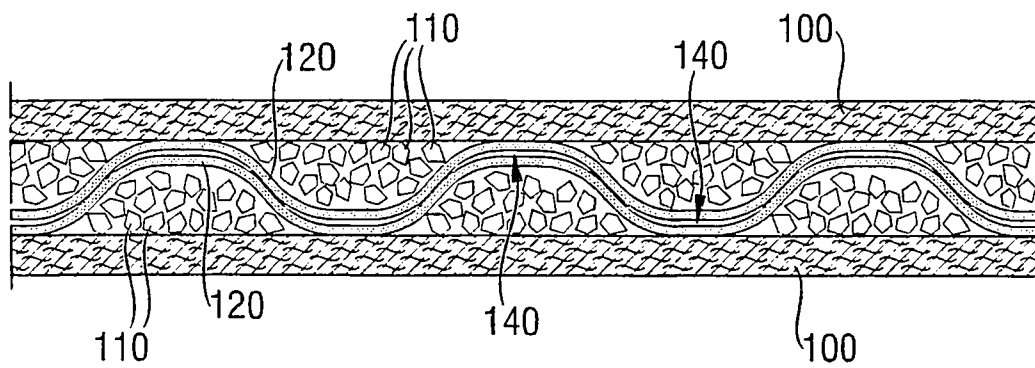
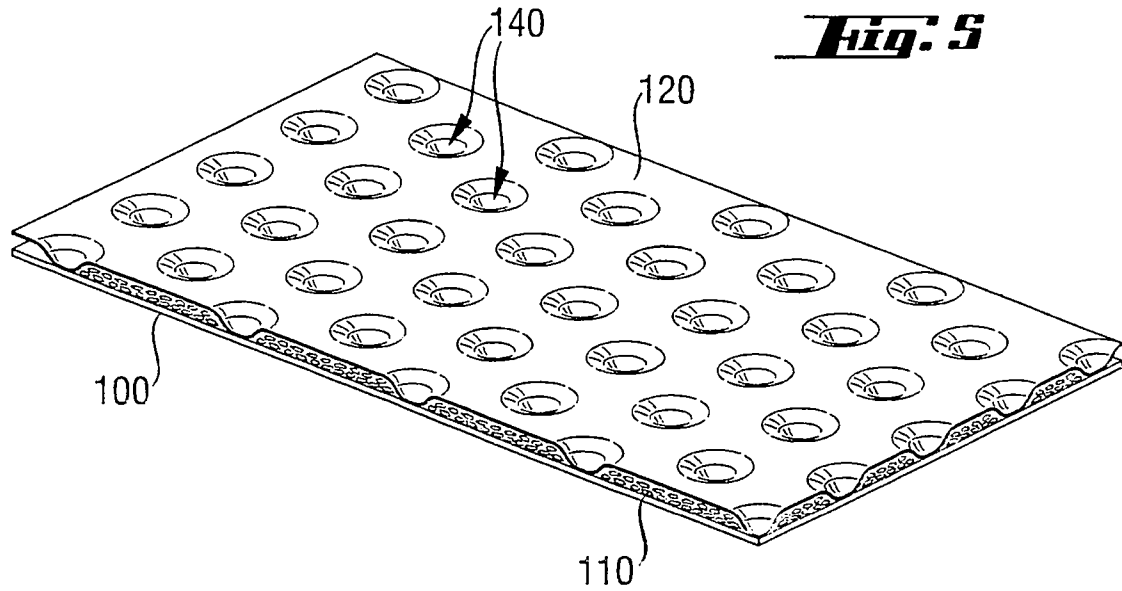

Fig. 4



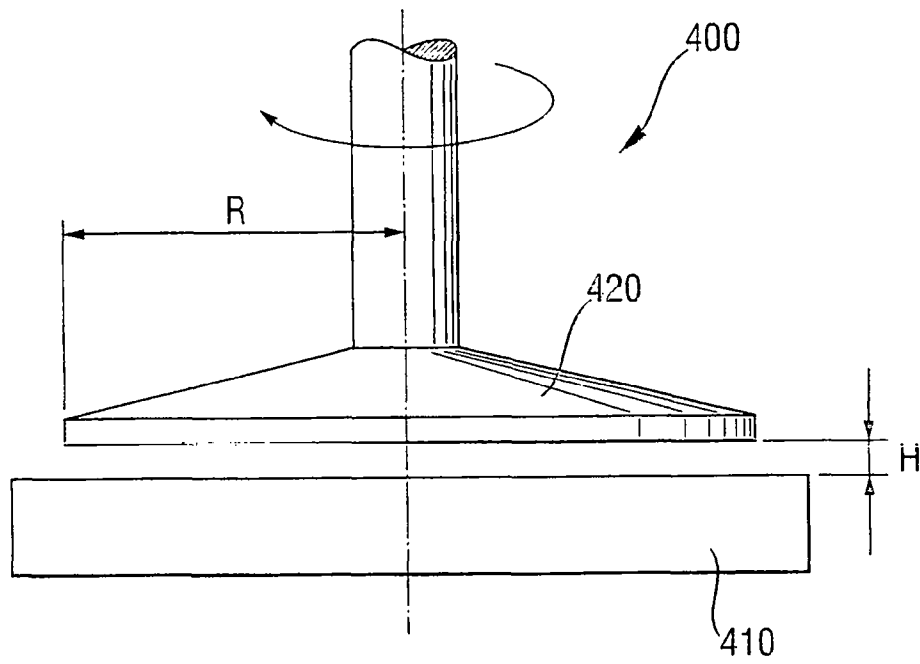

Fig. 3