



Europäisches Patentamt  
 European Patent Office  
 Office européen des brevets

Publication number:

**0 055 874  
 A3**

**EUROPEAN PATENT APPLICATION**

Application number: **81201132.8**

Int. Cl.<sup>3</sup>: **B 66 F 9/18**

Date of filing: **12.10.81**

Priority: **14.10.80 IT 2532080**

Date of publication of application:  
**14.07.82 Bulletin 82/28**

Date of deferred publication of search report: **13.04.83**

Designated Contracting States:  
**BE DE FR GB NL SE**

Applicant: **DELMACH S.r.l.**  
**Via Frassina**  
**I-54033 Carrara(IT)**

Inventor: **Fontanini, Claudio**  
**Via Livorno, 30**  
**Ronchi (Massa)(IT)**

Representative: **Dragotti, Gianfranco**  
**SAIC BREVETTI S.a.s. di Ing. G. Dragotti & C. Via**  
**Spontini, 1**  
**I-20131 Milano(IT)**

**Container hooking and moving frame for hoisting trucks.**

A hooking and moving frame of containers for front hoisting trucks the side arms of which, extensible through two stages, for the hooking of the container can be drawn back so that the maximum size of the frame, in the condition of maximum withdrawal of the extensible arms, is reduced, consistently with the requirements of structure strength, and does particularly permit the hoisting truck to pass through the loading and stowage doors of container carrying vessels without removal of the hooking frame.

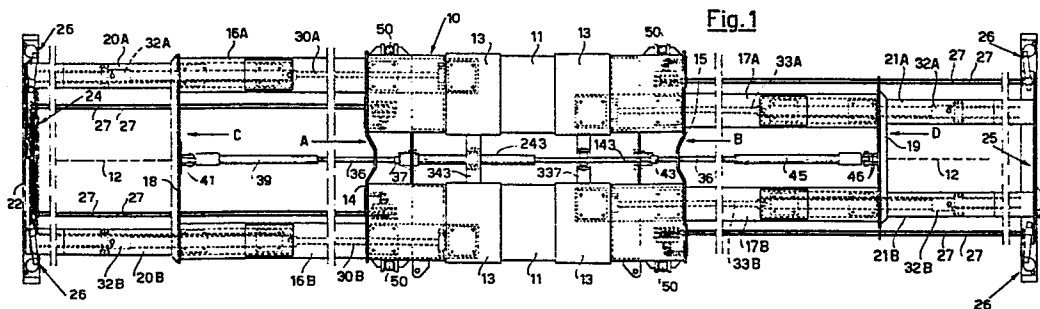

**EP 0 055 874 A3**



DOCUMENTS CONSIDERED TO BE RELEVANT			
Category	Citation of document with indication, where appropriate, of relevant passages	Relevant to claim	CLASSIFICATION OF THE APPLICATION (Int. Cl. <sup>3</sup> )
Y	<p style="text-align: center;">---</p> US-A-3 752 346 (THOMPSON et al.) * column 2, line 54-58; column 1, lines 49-55; figures 6,2 *	1,2,3,4	B 66 F 9/18
Y	<p style="text-align: center;">---</p> GB-A-2 031 841 (LANCER BOSS) * page 1, line 114 - page 2, line 7; figure 1 *	1,2,4,6	
A	<p style="text-align: center;">---</p> FR-A-2 169 796 (LIDHULTS MEKANISKA VERKSTAD) * page 2, lines 10-16; figure 1 *	2,7	
P,A	<p style="text-align: center;">---</p> GB-A-2 055 749 (GOSTA KARLSSON) * page 1, lines 67-71; figure 1 *	1,7	
A	<p style="text-align: center;">---</p> FR-A-2 312 447 (CONTAINER CARGO CARRIERS) * page 14, lines 8-16; figure 8 *	1	
-----			TECHNICAL FIELDS SEARCHED (Int. Cl. <sup>3</sup> )  B 66 F B 66 C
The present search report has been drawn up for all claims			
Place of search <b>THE HAGUE</b>		Date of completion of the search <b>14-01-1983</b>	Examiner <b>KERSHAW K.</b>
<b>CATEGORY OF CITED DOCUMENTS</b> X : particularly relevant if taken alone Y : particularly relevant if combined with another document of the same category A : technological background O : non-written disclosure P : intermediate document		T : theory or principle underlying the invention E : earlier patent document, but published on, or after the filing date D : document cited in the application L : document cited for other reasons & : member of the same patent family, corresponding document	