

CORRECTED VERSION

(19) World Intellectual Property Organization International Bureau



(10) International Publication Number WO 2016/193669 A8

(43) International Publication Date 8 December 2016 (08.12.2016)

- (51) International Patent Classification: *B32B 17/10* (2006.01) *H05B 3/86* (2006.01)
H05B 3/84 (2006.01)
- (21) International Application Number: PCT/GB2016/051478
- (22) International Filing Date: 23 May 2016 (23.05.2016)
- (25) Filing Language: English
- (26) Publication Language: English
- (30) Priority Data: 1509630.8 3 June 2015 (03.06.2015) GB
- (71) Applicant: PILKINGTON GROUP LIMITED [GB/GB]; European Technical Centre, Hall Lane, Lathom, Ormskirk Lancashire L40 5UF (GB).
- (72) Inventors: CHAMBERLAIN, Mark Andrew; European Technical Centre, Hall Lane, Lathom, Ormskirk Lancashire L40 5UF (GB). MELLOR, Leigh Francis; 32 Moss Lane, St Helens Merseyside WA11 7QD (GB). SCHNEIDER, Hartwig; Crengeldanzstrasse 52c, 58455 Witten (DE).
- (74) Agent: KNOWLES, James; Atherton Knowles, 29 Great George Street, Bristol Avon BS1 5QT (GB).
- (81) Designated States (unless otherwise indicated, for every kind of national protection available): AE, AG, AL, AM, AO, AT, AU, AZ, BA, BB, BG, BH, BN, BR, BW, BY, BZ, CA, CH, CL, CN, CO, CR, CU, CZ, DE, DK, DM, DO, DZ, EC, EE, EG, ES, FI, GB, GD, GE, GH, GM, GT, HN, HR, HU, ID, IL, IN, IR, IS, JP, KE, KG, KN, KP, KR, KZ, LA, LC, LK, LR, LS, LU, LY, MA, MD, ME, MG, MK, MN, MW, MX, MY, MZ, NA, NG, NI, NO, NZ, OM, PA, PE, PG, PH, PL, PT, QA, RO, RS, RU, RW, SA, SC,

[Continued on next page]

(54) Title: LAMINATED GLAZING

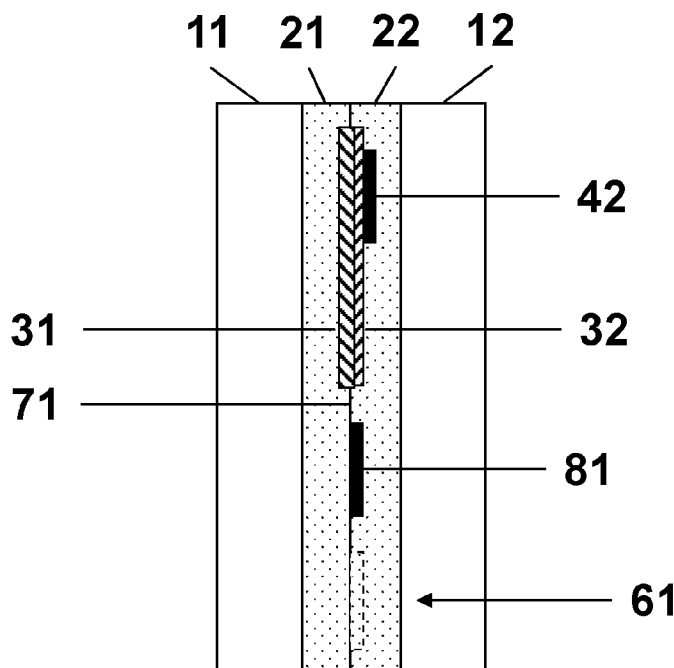

Fig. 6

(57) Abstract: A laminated glazing comprising, a first ply of a glazing material, a second ply of a glazing material, a film having an electrically conductive coating, the film being located between the first ply and the second ply, and a first busbar in electrical contact with the electrically conductive coating, the first busbar comprising an expansion portion, the expansion portion comprising a bridging busbar portion or a gap in the first busbar. Methods for producing the laminated glazing are also described.

WO 2016/193669 A8

SD, SE, SG, SK, SL, SM, ST, SV, SY, TH, TJ, TM, TN, TR, TT, TZ, UA, UG, US, UZ, VC, VN, ZA, ZM, ZW.

- (84) Designated States** (*unless otherwise indicated, for every kind of regional protection available*): ARIPO (BW, GH, GM, KE, LR, LS, MW, MZ, NA, RW, SD, SL, ST, SZ, TZ, UG, ZM, ZW), Eurasian (AM, AZ, BY, KG, KZ, RU, TJ, TM), European (AL, AT, BE, BG, CH, CY, CZ, DE, DK, EE, ES, FI, FR, GB, GR, HR, HU, IE, IS, IT, LT, LU, LV, MC, MK, MT, NL, NO, PL, PT, RO, RS, SE, SI, SK, SM, TR), OAPI (BF, BJ, CF, CG, CI, CM, GA, GN, GQ, GW, KM, ML, MR, NE, SN, TD, TG).

Declarations under Rule 4.17:

— *of inventorship (Rule 4.17(iv))*

Published:

— *with international search report (Art. 21(3))*

(48) Date of publication of this corrected version:

12 January 2017

(15) Information about Correction:

see Notice of 12 January 2017