

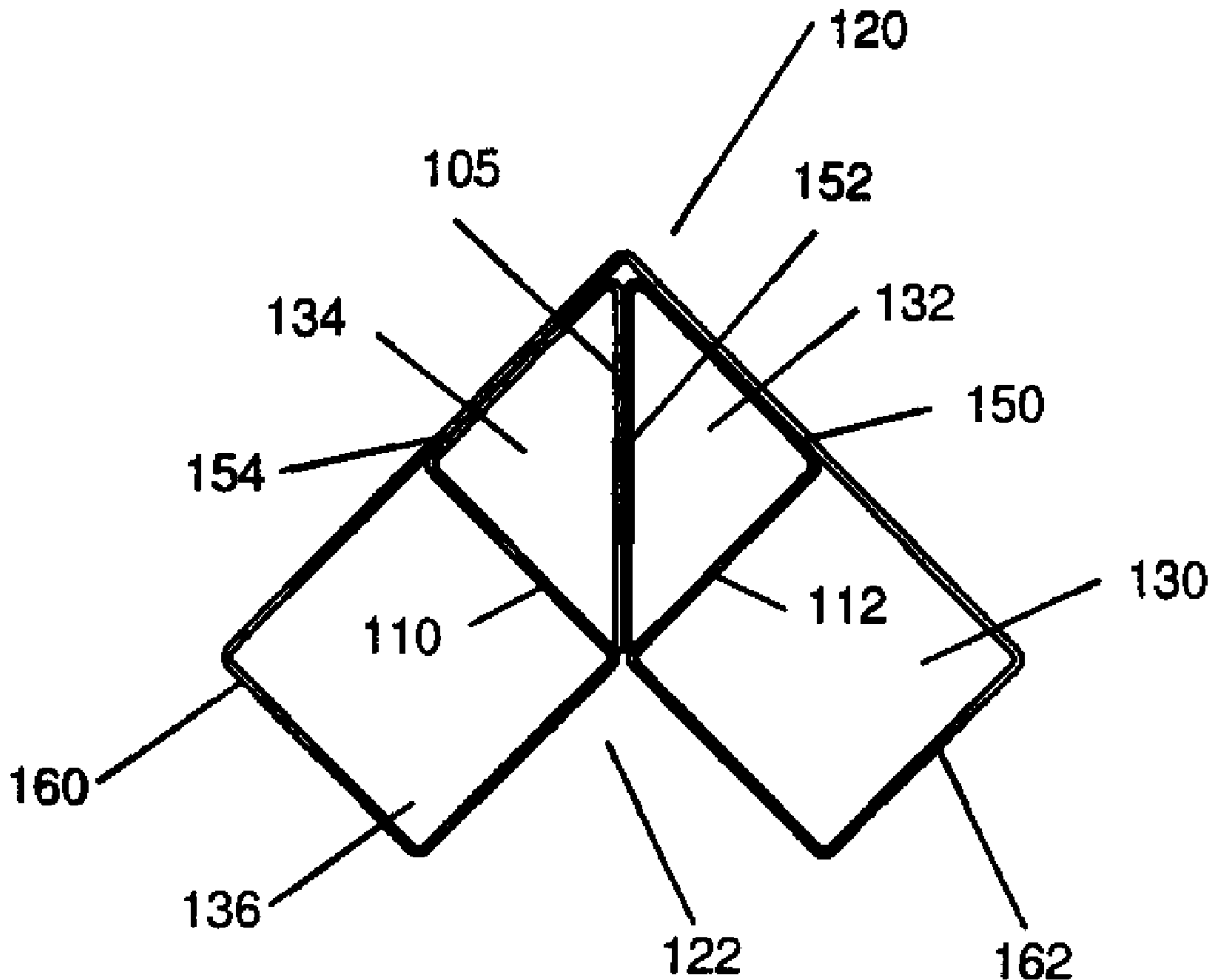

(22) Date de dépôt/Filing Date: 2008/05/16
(41) Mise à la disp. pub./Open to Public Insp.: 2009/11/16

(51) Cl.Int./Int.Cl. *E04B 1/30* (2006.01),
E04B 1/24 (2006.01), *E04B 1/26* (2006.01)
(71) Demandeur/Applicant:
PERRON, REMI, CA
(72) Inventeur/Inventor:
PERRON, REMI, CA
(74) Agent: BROUILLETTE & ASSOCIES/PARTNERS

(54) Titre : ELEMENT STRUCTURAL DE CONSTRUCTION DE MAISON EN RONDINS
(54) Title: STRUCTURAL ELEMENT FOR THE CONSTRUCTION OF LOG TYPE HOUSES



(57) Abrégé/Abstract:

The present invention provides a structural element for the construction of log type houses. The structural element comprises structural portions, preferably made of aluminum, and insulating material. The insulation coefficient of the structural element may be

(57) **Abrégé(suite)/Abstract(continued):**

adapted to the local climate. Furthermore, the structural element is less sensible to temperature and humidity variations than wood, preventing possible cracks to appear between adjacent structural elements.

File number: 11357-003
Revision: 4
Date: 16-05-2008

STRUCTURAL ELEMENT FOR THE CONSTRUCTION
OF LOG TYPE HOUSES

5 Abstract

The present invention provides a structural element for the construction of log type houses. The structural element comprises structural portions, preferably made of aluminum, and insulating material. The insulation coefficient of the structural element
10 may be adapted to the local climate. Furthermore, the structural element is less sensible to temperature and humidity variations than wood, preventing possible cracks to appear between adjacent structural elements.

File number: 11357-003
Revision: 4
Date: 16-05-2008

Title of the Invention

[0001] Structural Element for the Construction of Log Type Houses

5 **Cross-Reference to Related Applications**

[0002] There are no cross-related applications.

Field of the Invention

10

[0003] The present invention generally relates to structural elements, and more particularly to a structural element for the construction of log type houses.

Background of the Invention

15

[0004] Conventional building techniques, featuring, for example, wood frame, precast and/or concrete block construction are relatively complicated and labor intensive. As a result, construction costs continue to escalate.

20

[0005] Traditional log homes remain popular as an alternative to more common building techniques. Nonetheless, wood log construction can also be intricate and time consuming. The individual logs must be precisely cut and shaped. Often a considerable amount of material is wasted in the construction process. The configurations and layouts available using log construction are also quite limited. And because traditional log homes are
25 composed of wood, they are very susceptible to fire damage.

30

[0006] Log homes have been in existence and common use for centuries. Originally, log cabins were built in wooded areas where there was a large supply of wooden logs from trees. Because log homes are still considered versatile, energy efficient structures, many modern improvements have been made to the log home. The majority of the improvements attempt to minimize the amount of labor involved in erecting a log home while improving the overall integrity of the structure.

File number: 11357-003
Revision: 4
Date: 16-05-2008

[0007] A problem with the structures disclosed above is that most of them require a great deal of on-site construction and labor. In the areas where log homes are very popular, the weather tends to limit the amount of building time available in a given year. Another
5 disadvantage is that many of those structures do not use real wood logs, but instead use building panels that simulate the appearance of a log home. Therefore, what is needed is a structural element that may be prefabricated and that do not need any special or unusual skills or tools to construct a log house or the like.

10 **Objects of the Invention**

[0008] A first object of the present invention is to provide a structural element for the construction of a log house or the like.

15 [0009] A second object of the present invention is to provide a structural element which is prefabricated and inexpensive.

[0010] A third object of the present invention is to provide a structural element with which it is easy to construct a log house or the like with no need to use special tool or
20 with no need to have unusual skills.

[0011] Other and further objects and advantages of the present invention will be obvious upon an understanding of the illustrative embodiments about to be described or will be indicated in the appended claims, and various advantages not referred to herein will occur
25 to one skilled in the art upon employment of the invention in practice.

Summary of the Invention

[0012] The aforesaid and other objectives of the present invention are realized by
30 generally providing an insulated structural element for the construction of log like houses or the like, the structural element having a cross-section, the structural element being adapted to be disposed one on top of another one, the cross-section of the preferred

File number: 11357-003
Revision: 4
Date: 16-05-2008

structural element comprising a L-shaped top surface, a L-shaped bottom surface, a first portion extending between the top surface and the bottom surface, a second portion extending between the top surface and the bottom surface and wherein the cavities formed by the top surface, the bottom surface, the first portion and the second portion are
5 filled with an insulating material.

[0013] The structural element of the present invention is used to construct walls of log houses or the like. As used herein, the word 'log' refers to any structural element having a general configuration which is log like and not limited to logs made of wood. The
10 structural elements are disposed one on top of other as usually seen in log houses. The log like structural element comprises structural portions and insulating material. The insulation coefficient of the structural element of the present invention may be adapted to a plurality of climate by varying the insulation properties of the insulating material. This is a notable advantage compared to logs made from wood, more particularly in extreme
15 climates to control the internal temperature of the log house. Indeed, in colder climates such as in the northern parts of America and Europe, a higher insulation coefficient may be chosen.

[0014] Another advantage is that the structural element of the present invention is not as
20 sensible as a wood log to the variations of volume following the variations of temperature and of humidity rates. This minimizes the risk of openings or cracks that appear between adjacent logs thus improving the insulation properties of the log house.

[0015] To provide good structural properties to the wall of the log house, internal
25 portions may be added into the structural element. For example, the structural element may further comprises a third portion and a fourth portion extending from the bottom surface and the top surface, the upward extremities of the third portion and the fourth portion being perpendicular to the top surface. Other examples are detailed in the preferred embodiment section and are not limited to these examples. The internal portions
30 are made preferably from the same material as the external portions. External portions are preferably made from aluminum because it is light and easy to shape but other materials

File number: 11357-003
Revision: 4
Date: 16-05-2008

may be used. The different portions may be glued together or welded to improve the structural integrity of the structural element.

5 [0016] The insulating material is preferably a foam type so that the structural has good insulating properties and is still light weighted. The foam may be of the expandable foam type such as, for example, urethane. The foam may also be provided in block form, the blocks having a shape that is complementary to the cavities of the structural element and that are inserted into the structural element.

10 [0017] The structural element may be made by folding a metal sheet or by assembling a plurality of portions together. In both case, the structural element may be welded or glued at the junction of different portions. The structural element may also be made by forming a tubular section in which sections may be inserted to improve the structural integrity. The structural element may also be extruded. There are many glues available for metals,
15 and more particularly for aluminum there are glues in the family of, for example, epoxy (ex: Hysol TM), polyurethane, acrylic, or silicon.

[0018] Problems with thermal bridges can be readily overcome or minimize by using methods known in the art. One example is detailed in the preferred embodiments section.

20

[0019] Because the structural element is constructed, it is possible to create almost any profile, such as rounded-like logs. The structural element may comprise built-in clapboard so the external look of the log house is different from the log house type.

25 [0020] It is also possible to laminate actual wood strips onto the outside of the structural elements to create a wood log appearance.

[0021] It is very easy to construct a log house with the structural element of the present invention. There is no need to have the unusual skills or tools usually needed for the
30 construction of log house because the structural elements are ready to use and just have to be installed one on top of the others.

File number: 11357-003
Revision: 4
Date: 16-05-2008

[0022] The features of the present invention which are believed to be novel are set forth with particularity in the appended claims.

Brief Description of the Drawings

5

[0023] The above and other objects, features and advantages of the invention will become more readily apparent from the following description, reference being made to the accompanying drawings in which:

10 [0024] Figure 1 is a cross-sectional view of a first embodiment of the present invention.

[0025] Figure 2 is a top view of the metal sheet used which is folded to create the structural element of the embodiment shown in Figure 1.

15 [0026] Figure 3 is a perspective view of the embodiment shown in Figure 1.

[0027] Figure 4 is a cross-sectional view of a variation of the embodiment shown in Figure 1, wherein the sides of the structural element are rounded.

20 [0028] Figure 5 is a cross-sectional view of the a variation of the embodiment shown in Figure 1, where the structural element further comprises a clapboard.

[0029] Figures 6 and 7 are a front view and a perspective view of an end cap.

25 [0030] Figure 8 is cross-sectional view showing another embodiment of the present invention.

[0031] Figure 9 is cross-sectional view showing another embodiment of the present invention.

30

[0032] Figure 10 is a schematic view illustrating a method to construct or produce the structural element of the present invention by press-forming.

File number: 11357-003
Revision: 4
Date: 16-05-2008

[0033] Figure 11 is a perspective view of an embodiment of the structural element.

5 [0034] Figure 12 is a top view showing the metal sheet used to construct or produce the embodiment of the structural element shown in Figure 11.

[0035] Figures 13a to 13c are a front view and two perspective views, respectively, showing a method to construct or produce the structural element of the present invention.

10 [0036] Figure 14a is a side view showing the structural element.

[0037] Figure 14b is a perspective view showing the structural element of the present invention with an end cap.

15 [0038] Figure 15 is a perspective view showing structural elements as used to construct a wall.

[0039] Figure 16 is a perspective view showing a structural element on which a strip of wood laminate is applied.

20

Detailed Description of the Preferred Embodiment

[0040] A novel structural element will be described hereinafter. Although the invention is described in terms of specific illustrative embodiment(s), it is to be understood that the embodiment(s) described herein are by way of example only and that the scope of the invention is not intended to be limited thereby.

[0041] Figure 1 illustrates the structural element of the present invention. The structural element has a generally L-shaped element with a top surface 120 and a bottom surface 122, the top surface 120 and the bottom surface 122 are L-shaped and are connected by two portions, a first portion 160 and a second portion 162 extending between them. The

30

File number: 11357-003
Revision: 4
Date: 16-05-2008

structural element is adapted to be disposed on the top of another structural element, the top surface 120 and the bottom surface 122 having a complementary shape.

5 [0042] A vertical portion 105 extends between the top surface 120 and the bottom surface 122. A third portion 110 and a fourth portion 112 extend between the top surface 120 and the bottom surface 122, their upward extremities being perpendicular to the top surface 105. The cavities 132, 134, 136 and 138 are filled with an insulating material (not shown).

10 [0043] The embodiment shown in Figure 1 may be made by folding the metal sheet shown in Figure 2. The metal sheet 200 is folded along the horizontal lines illustrated in Figure 2 to create the structural element of Figure 1. Glue may also be applied where the surfaces of the metal sheet are in contact (150, 152, 154).

15 [0044] The Figure 4 shows an embodiment similar to the one presented in Figure 1, except that the sides are rounded, providing a different look. The structural element is preferably welded along its length at the intersection of the different portions such as indicated by the welding cords 142, 144, 146 and 148.

20 [0045] In Figure 5, a clapboard portion 210 is added to the structural element to give another look. The clapboard portion 210 illustrated is shown as being vertical once installed but it may be oriented differently. The clapboard portion 210 is preferably integral to the structural element although it could be an add-on made of the same or different material as the structural element. It could even be made out of real wood.

25 [0046] Figures 6 and 7 show an end cap used to cover the extremities of the structural element. The end cap has a shape that is complementary to the shape of the cooperating structural element. The end cap may be fixed to the structural with, for example, glue or be welded to it. The lines illustrated 280 on the end cap may be added to simulate a wood
30 beam.

File number: 11357-003
Revision: 4
Date: 16-05-2008

[0047] In Figures 8 and 9, transversal portions are added to the structural element. In Figure 8, substantially horizontal portions 202 and 204 are extending between the top surface 120 and the bottom surface 122. In Figure 9, there are vertical portions 206 and 208 extending between the top surface 120 and the bottom surface 122.

5

[0048] Figure 10 illustrates another method to produce the structural element of the present invention. The tube 300 is pressed to obtain the desired external shape of the structural element 302. The internal portion 304 is then inserted in the external portion 300 and preferably welded to it as shown by the welding cords 310, 312, 314 and 316.

10 The internal portion 302 illustrated may be composed by a plurality of parts. These parts may be assembled and welded before they are inserted in the external portion or after. It is to be understood that it is possible to have other configurations for the internal portion.

[0049] Figure 12 shows another embodiment of the present invention. The structural element 352 is made by folding a metal sheet 350 shown in Figure 11 along the horizontal lines. The structural element 352 is preferably welded as shown by the welding cords 360.

[0050] In Figures 13a to 13c, another method is shown for the construction of the structural element. The structural element 406 is made from a first part 402 and a second part 404. To minimize problems caused by thermal bridges, non-conductive elongated parts 420 and 422 are fixed to the second part 404. The elongated parts 420 and 422 are made from a material such as polyamide, for example, and may be reinforced with fibreglass. Receiving elongated parts 424 and 426, adjacent to the first part 402, are adapted to receive the elongated parts 420 and 422. Prior to join the first part 402 to the second part 404, an adhesive is applied on the elongated parts 420 and 422 and/or (depending of the instructions for the adhesive used) on the receiving elongated parts 424 and 426. As previously mentioned in the summary, the adhesive may be, but not limited to, an epoxy or polyurethane. The receiving elongated parts 424 and 426 may be added to the first part 402 or may be unitary with the first part 402. As shown in Figure 13c, the thermal flux is stopped or minimized at the junctions 410 and 412 of the elongated parts 420 and 422 and the receiving elongated parts 424 and 426.

File number: 11357-003
Revision: 4
Date: 16-05-2008

5 [0051] The structural element shown in Figures 14a, 14b and in Figure 15 comprises two inverted 'V' notches 502 and 504 allowing the structural elements to be disposed one on the other. Indeed, the notches 502 and 504, which are transversal, have a shape which is complementary to the shape of the top surface 510 of the structural element 500. The notches may be done by, for example, sawing the structural element to create the desired shape for the notches. The structural element 500 of Figure 14a and 14b comprises an end cap 154. When the structural elements are stacked one on the other, to seal the opening made by sawing the structural element, a seal joint may be add between adjacent
10 structural elements. The openings could also be sealed prior to be assembled by applying a layer of sealing material such as epoxy. In an other embodiment, a plate having a complementary shape is welded to the structural element, closing the opening created by sawing the notches.

15 [0052] The structural element 525 shown in Figure 16 is covered by a strip of wood laminate 530. The strip of wood laminate 530 is fixed on the structural element 525 with methods known in the art, such as with an adhesive adapted for wood laminate and aluminum (for a structural element made of aluminum).

20 [0053] While illustrative and presently preferred embodiment(s) of the invention have been described in detail hereinabove, it is to be understood that the inventive concepts may be otherwise variously embodied and employed and that the appended claims are intended to be construed to include such variations except insofar as limited by the prior art.

File number: 11357-003
Revision: 4
Date: 16-05-2008

Claims

1. A structural element for the construction of log like houses or the like, said element comprising:
 - 5 a) a shell made of a rigid material; and
 - b) insulating material disposed within said shell.
2. A structural element as claimed in claim 1, wherein said shell comprises:
 - 10 a) an L-shaped top surface;
 - b) an L-shaped bottom surface;
 - c) a first portion extending between said top surface and said bottom surface;
 - d) a second portion extending between said top surface and said bottom surface.
3. A structural element as claimed in claim 1, further comprising internal reinforcing
15 portions.
4. The structural element as claimed in claim 3, further comprising a vertical portion extending between said top surface and said bottom surface.
- 20 5. The structural element as claimed in claim 3, further comprising at least a horizontal portion extending in said structural element.
6. The structural element as claimed in claim 3, further comprising a third portion and a fourth portion extending from said bottom surface and said top surface, the upward
25 extremities of said third portion and said fourth portion being perpendicular to said top surface.
7. The structural element as claimed in claim 1, further comprising strips of wood fixed on said shell.
30
8. The structural element as claimed in claim 1, further comprising a clapboard portion that is unitary with said structural element.

File number: 11357-003
Revision: 4
Date: 16-05-2008

9. The structural element as claimed in claim 1, further comprising clapboard made of wood.
- 5 10. The structural element as claimed in claim 2, wherein said first portion and said second portion are perpendicular to said top surface.
11. The structural element as claimed in claim 2, wherein adjacent extremities of said top surface and said first portion are rounded and tangential to each other.
- 10 12. The structural element as claimed in claim 2, wherein adjacent extremities of said top surface and said second portion are rounded and tangential to each other.
13. The structural element as claimed in claim 1, wherein said structural element further
15 comprises at least one transversal notch, said transversal notch having the shape of an inverted 'V'.
14. The structural element as claimed in claim 9, wherein said structural element further
20 comprises sealing means to seal said at least one notch.
15. The structural element as claimed in claim 1, further comprising means to prevent thermal bridges.
16. The structural element as claimed in claim 15, further comprising at least one
25 elongated part made from a non-conductive material, said at least one elongated part being fixed to said structural element.
17. The structural element as claimed in claim 16, further comprising at least one
30 receiving elongated part made that have a shape complementary to the shape of said elongated part, said at least one receiving elongated part being fixed to said structural element and to said elongated part.

File number: 11357-003
Revision: 4
Date: 16-05-2008

18. The structural element as claimed in claim 2, further comprising an end cap having a complementary shape to the shape of the cross-section of said structural element.

19. The structural element as claimed in claim 1, wherein said shell is made from metal.

5

20. The structural element as claimed in claim 1, wherein said shell is made from aluminum.

21. The structural element as claimed in claim 1, wherein said insulating material is insulating expandable foam.

10

* * *

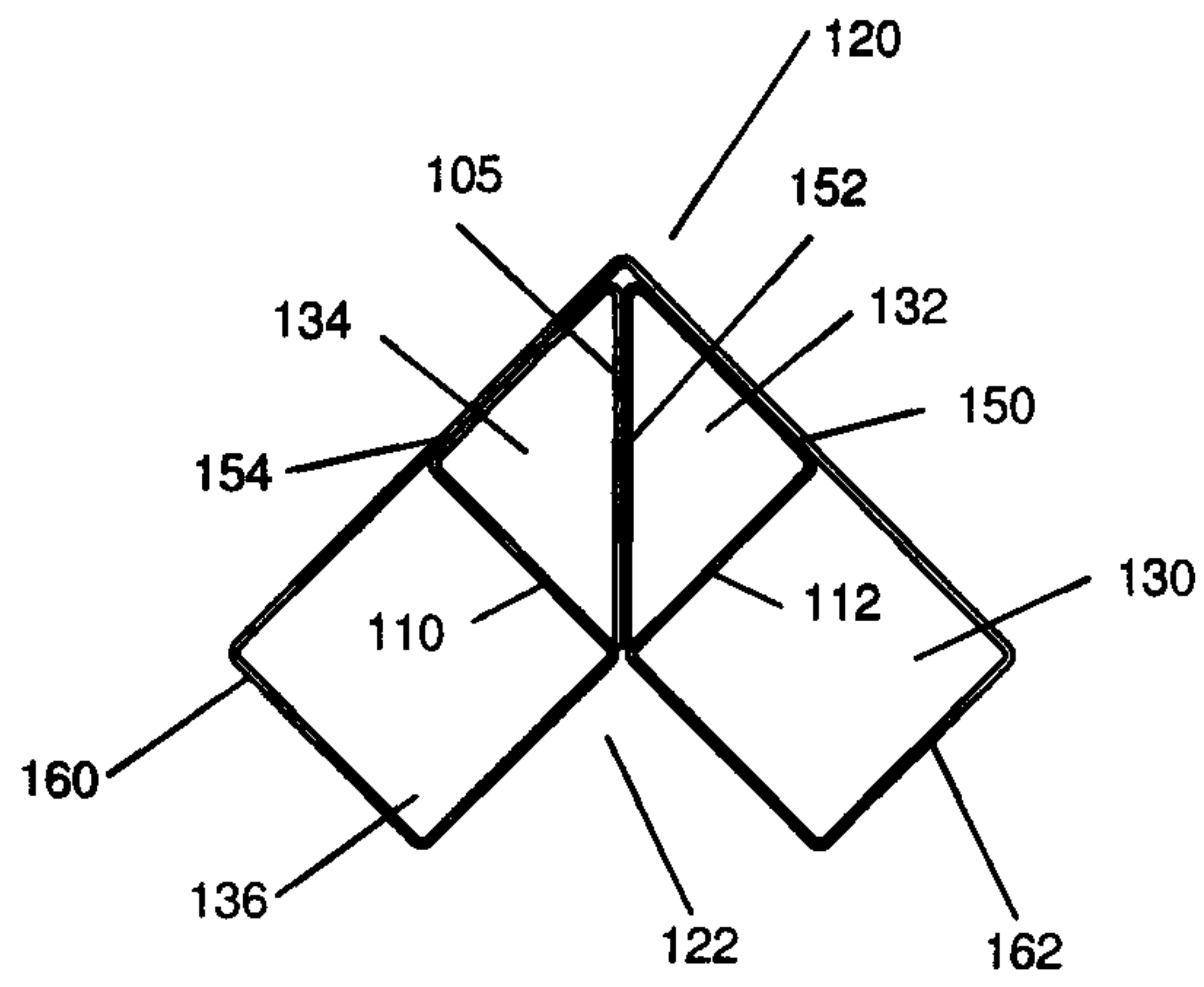

FIGURE 1

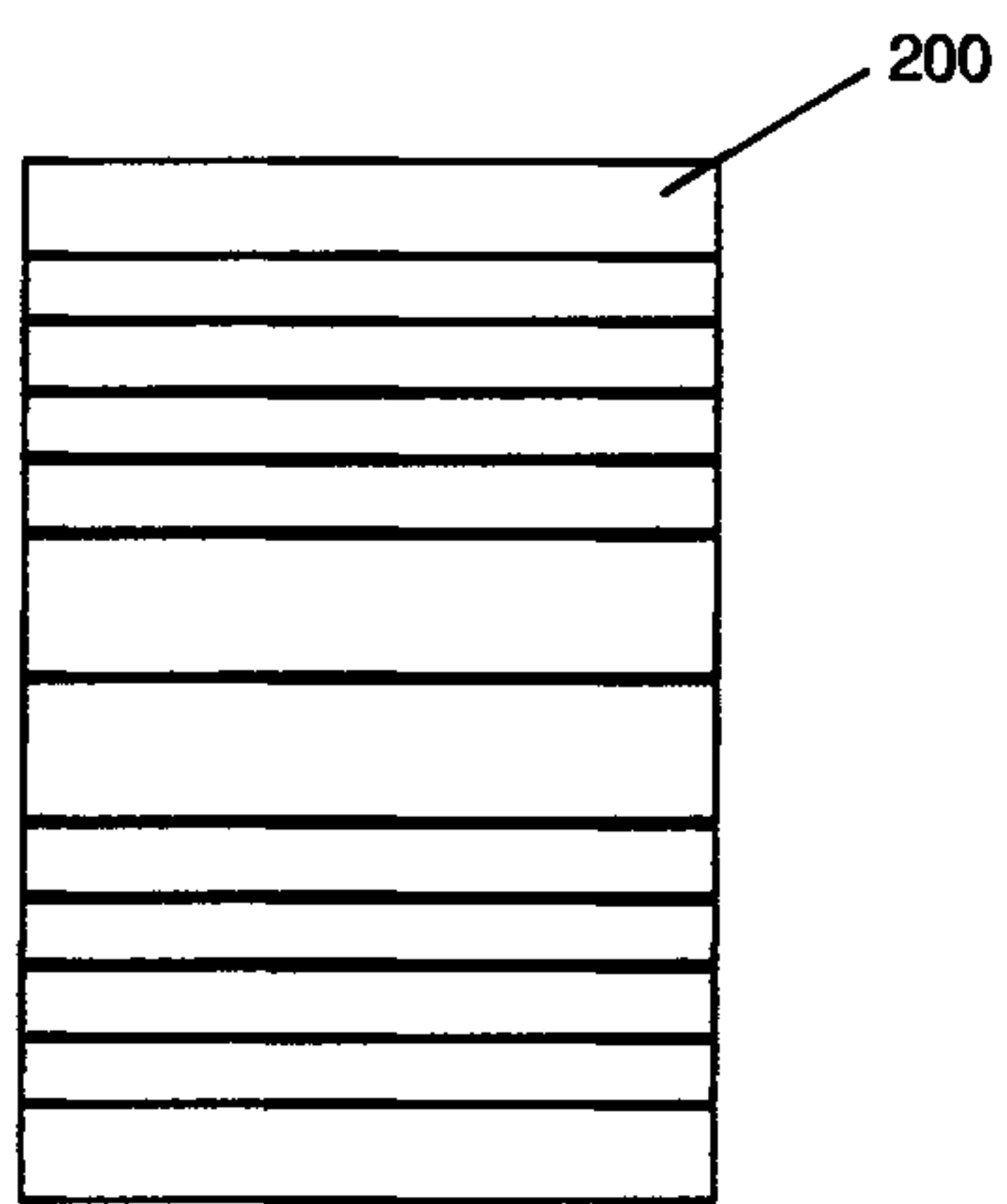

FIGURE 2

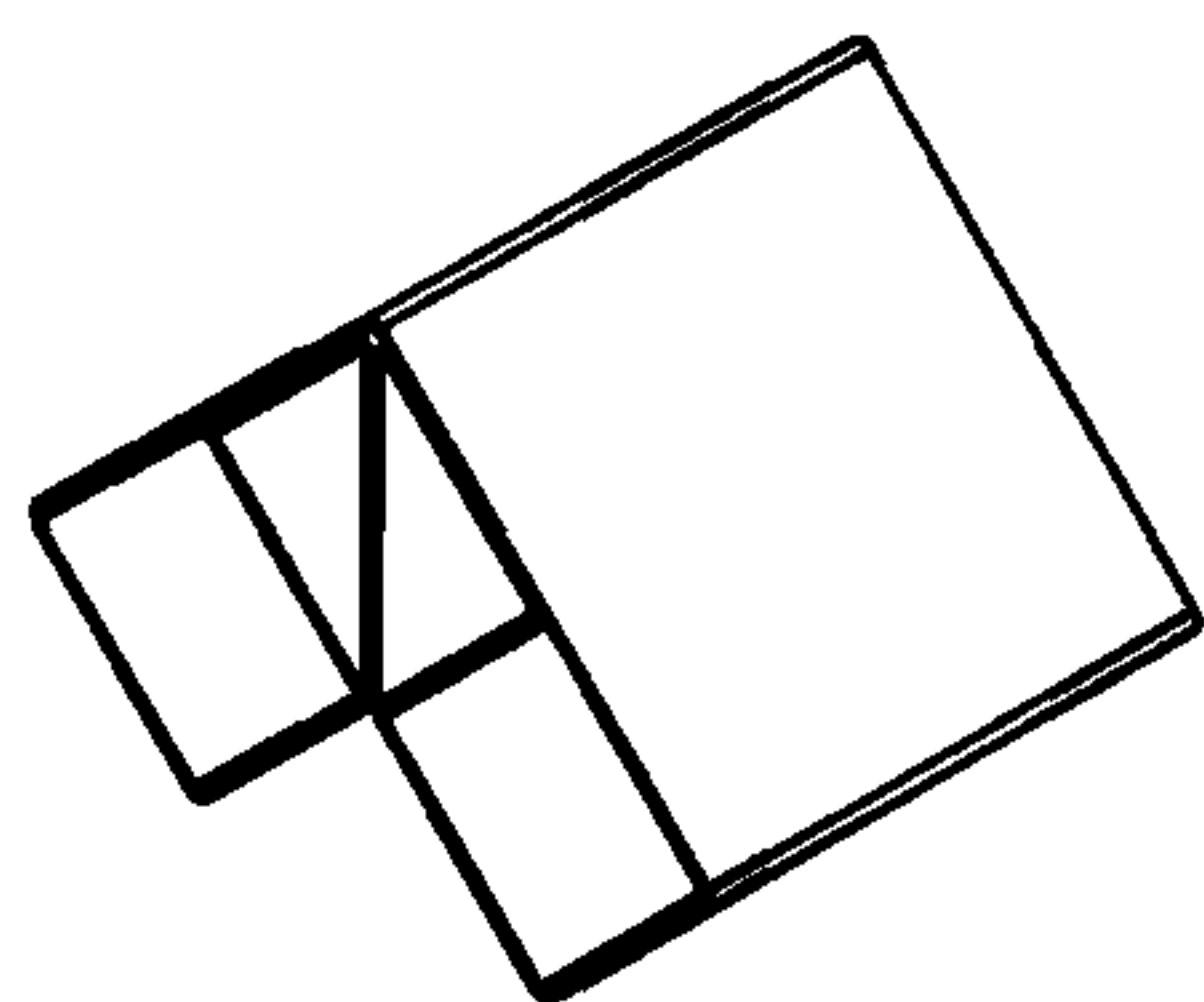

FIGURE 3

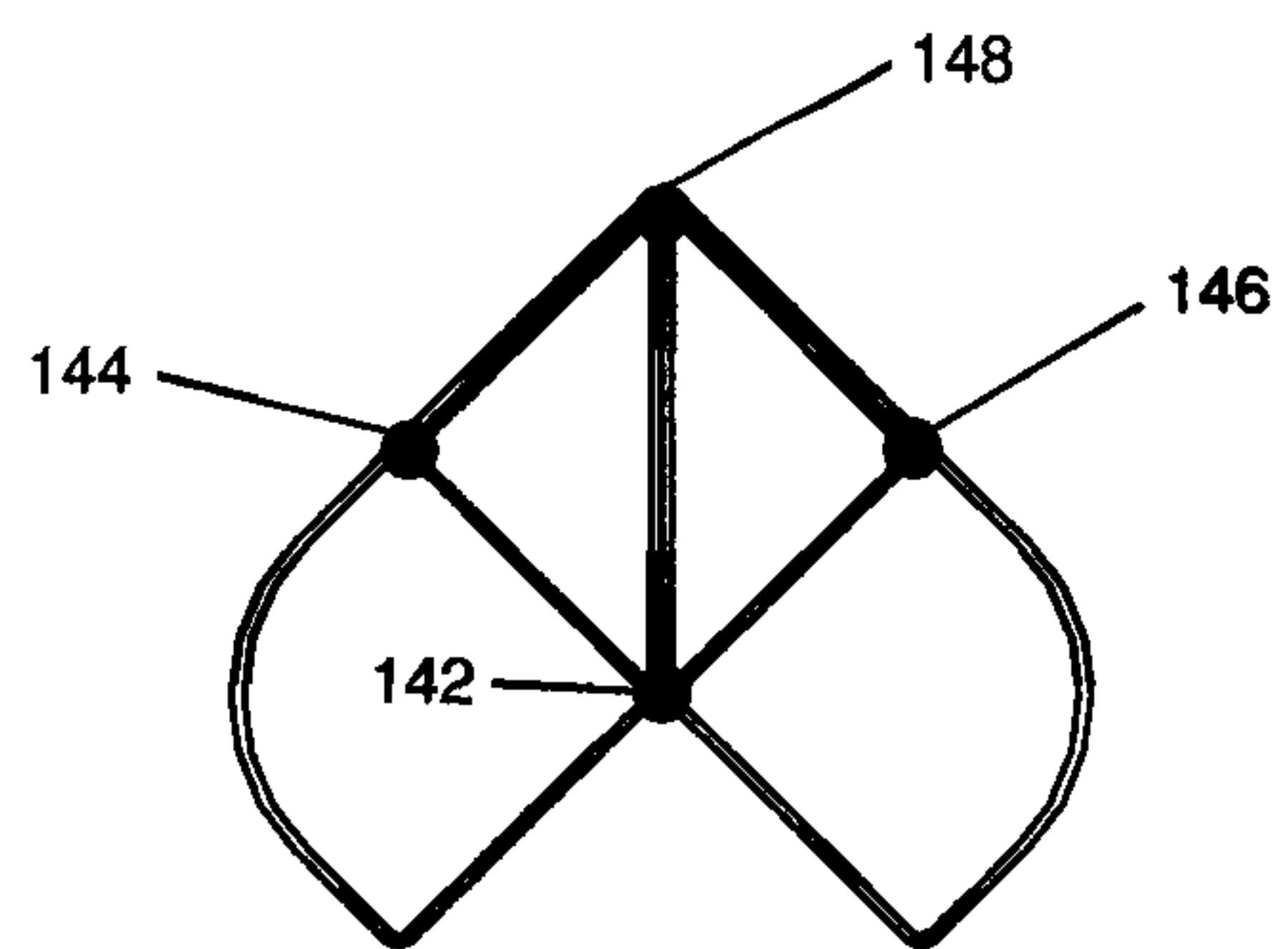

FIGURE 4

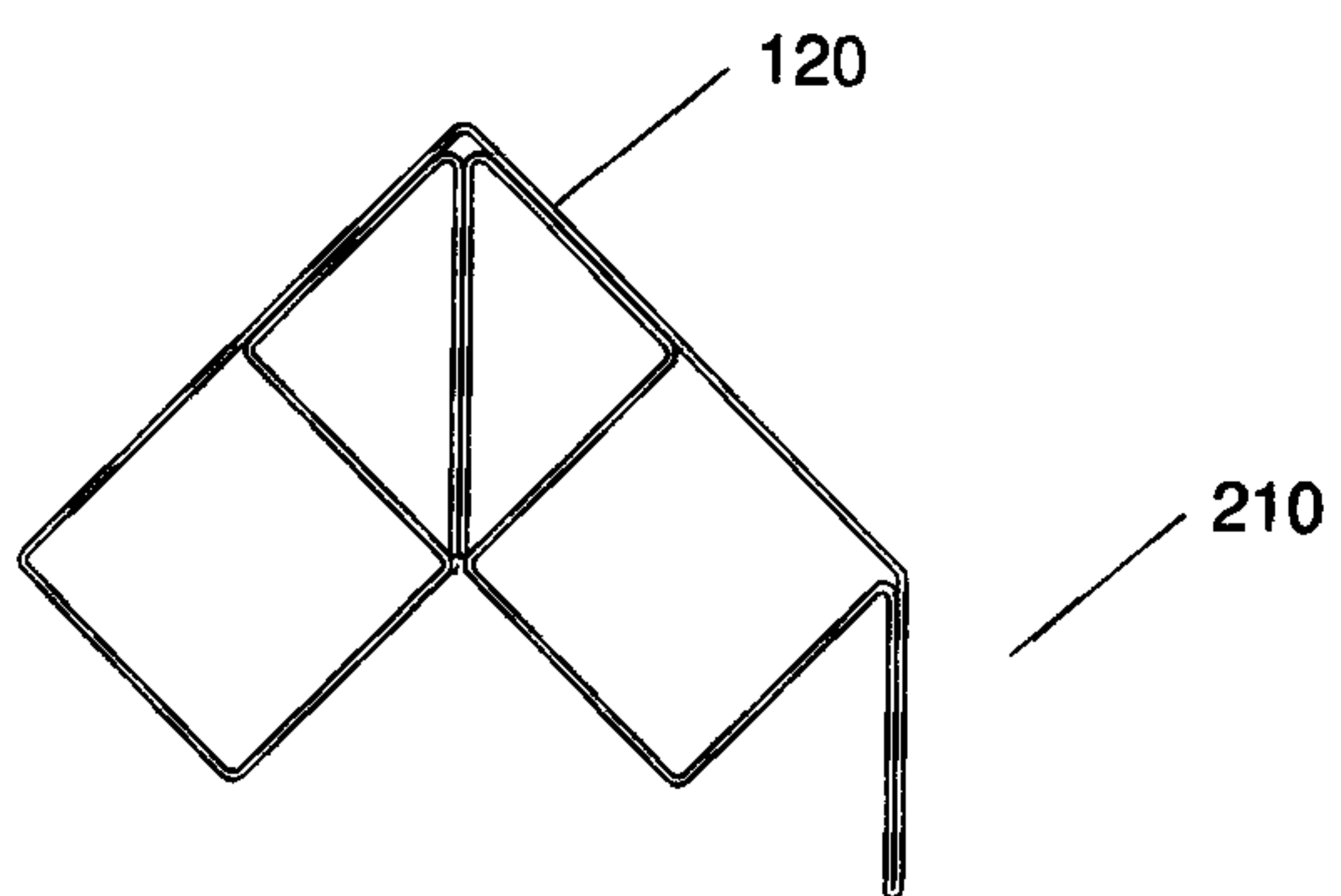

FIGURE 5

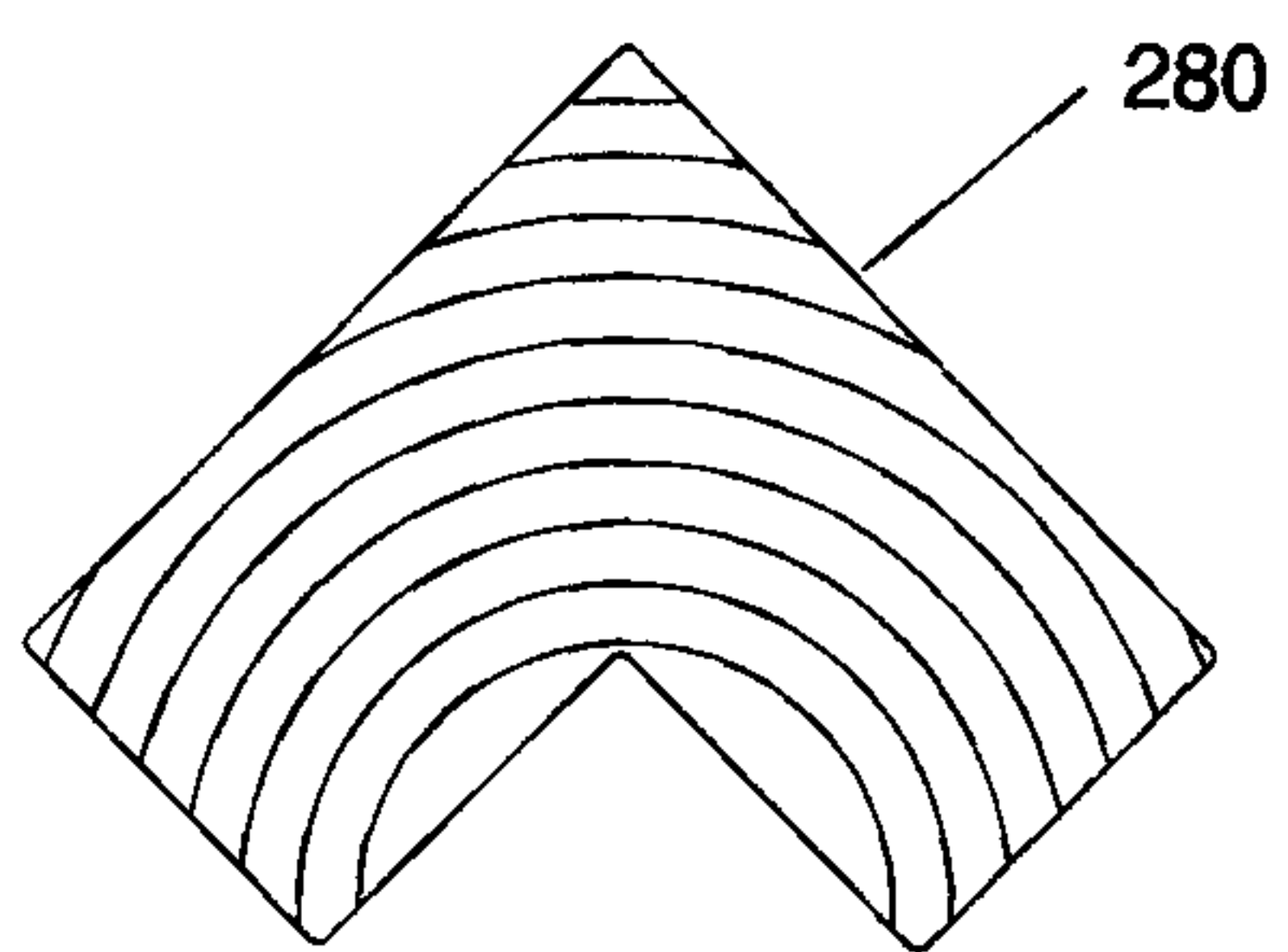

FIGURE 6

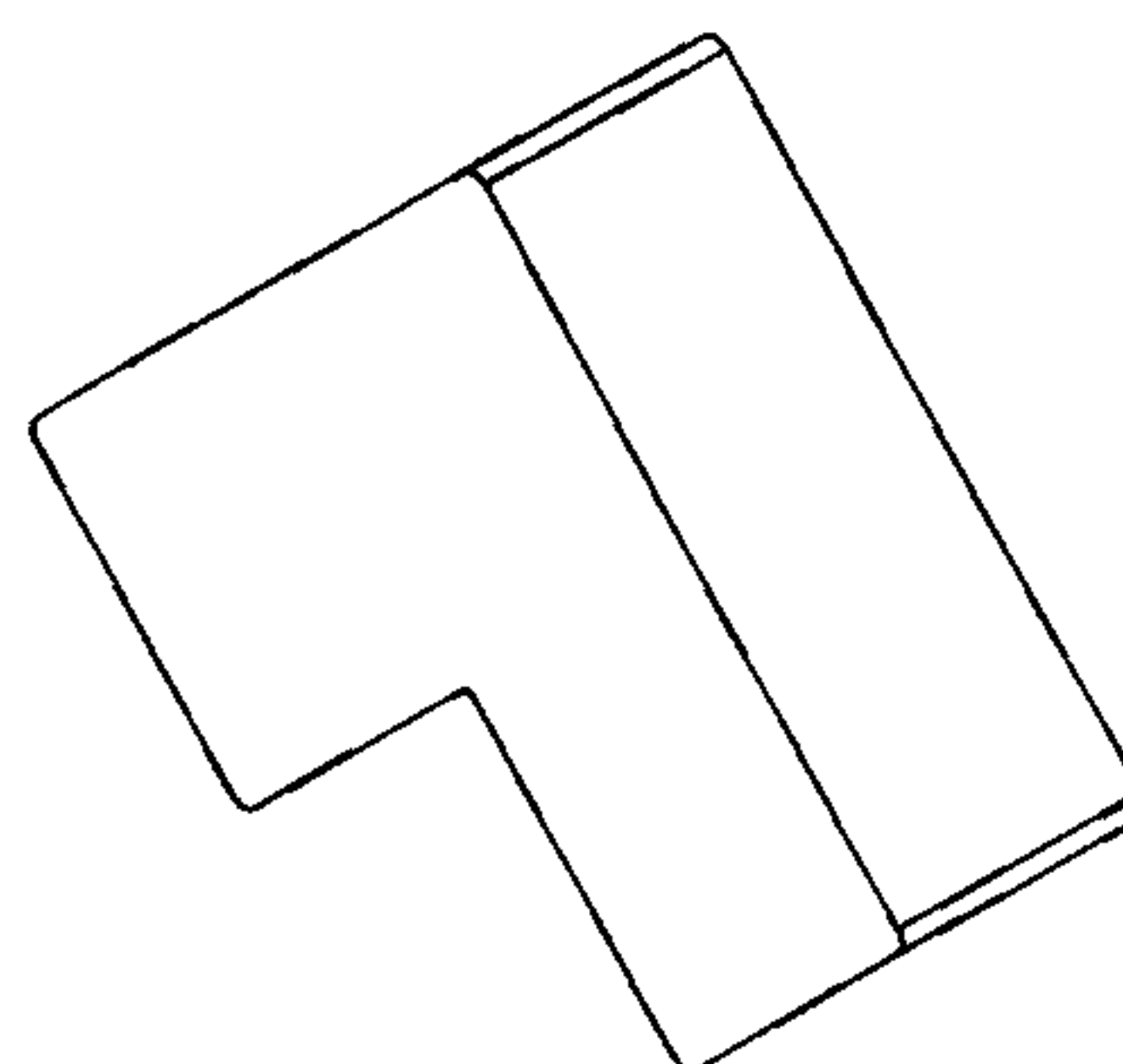

FIGURE 7

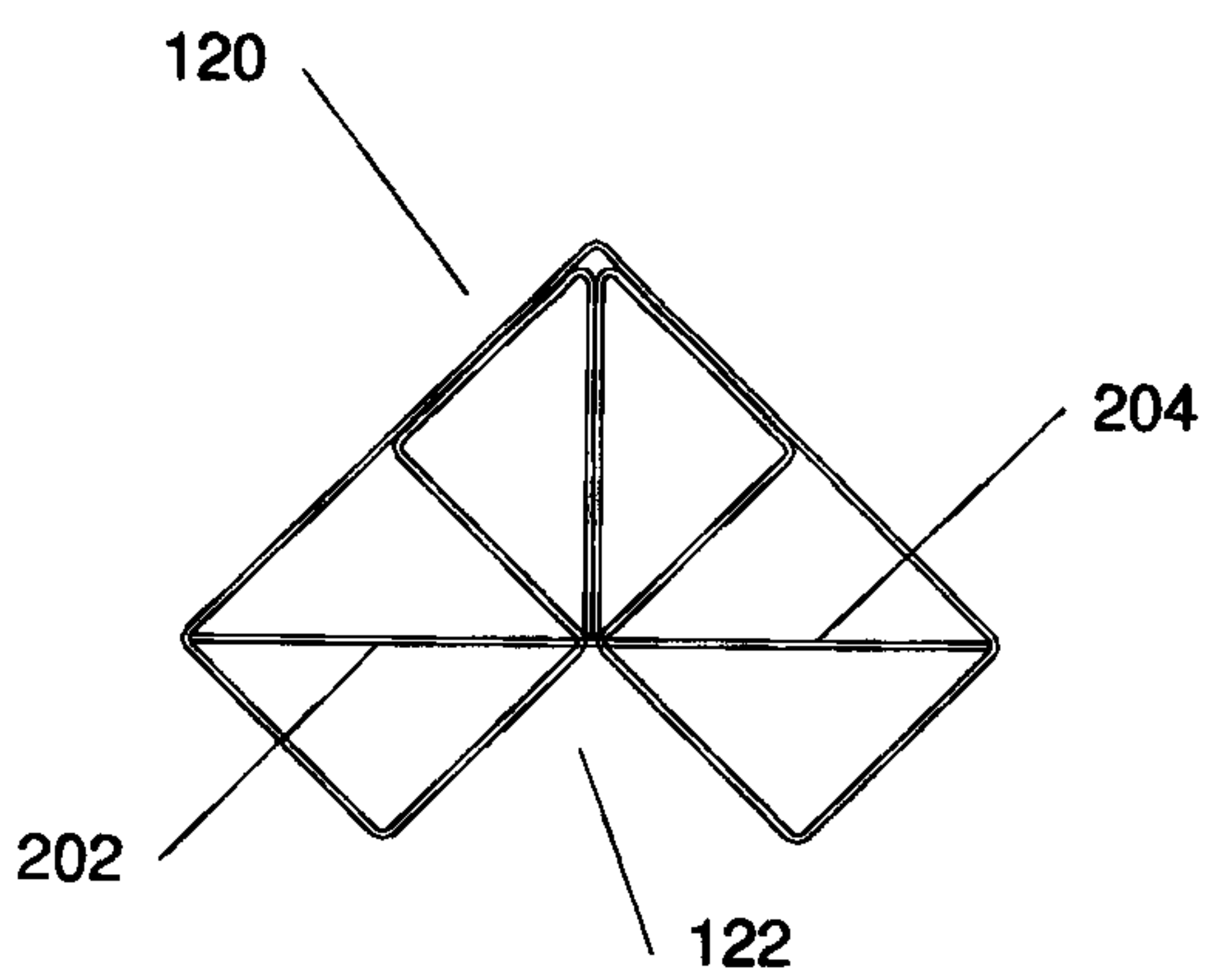

FIGURE 8

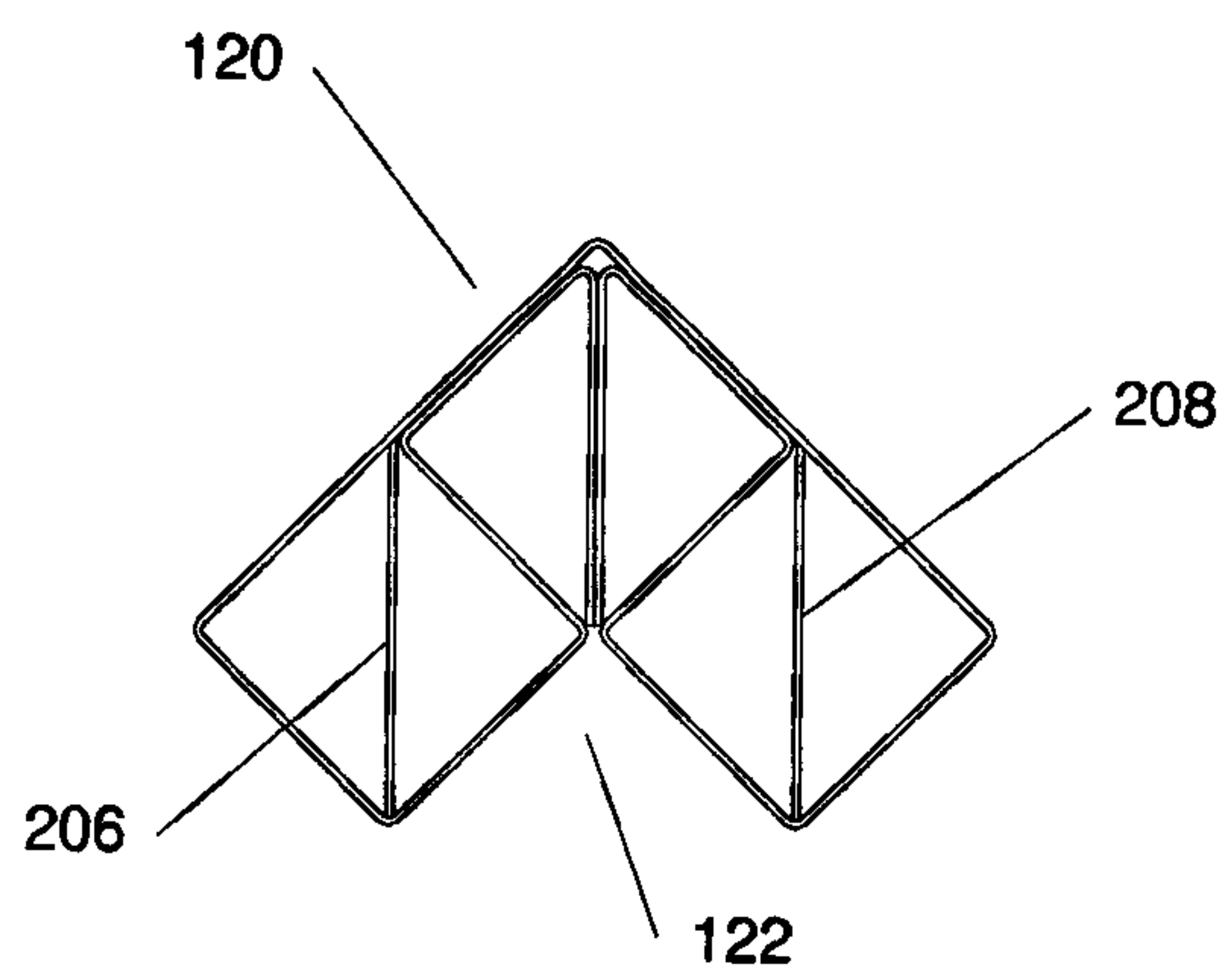

FIGURE 9

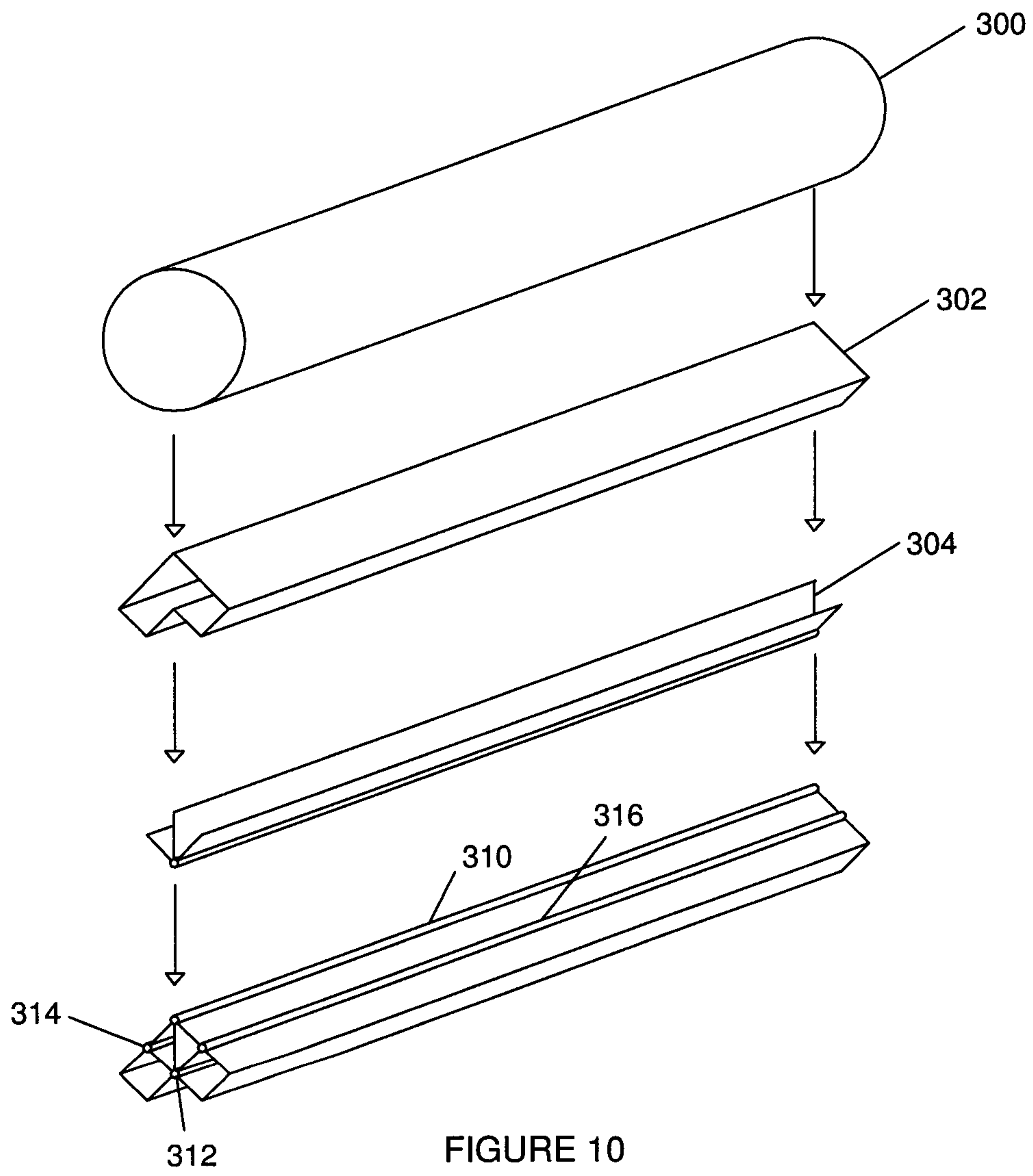

FIGURE 10

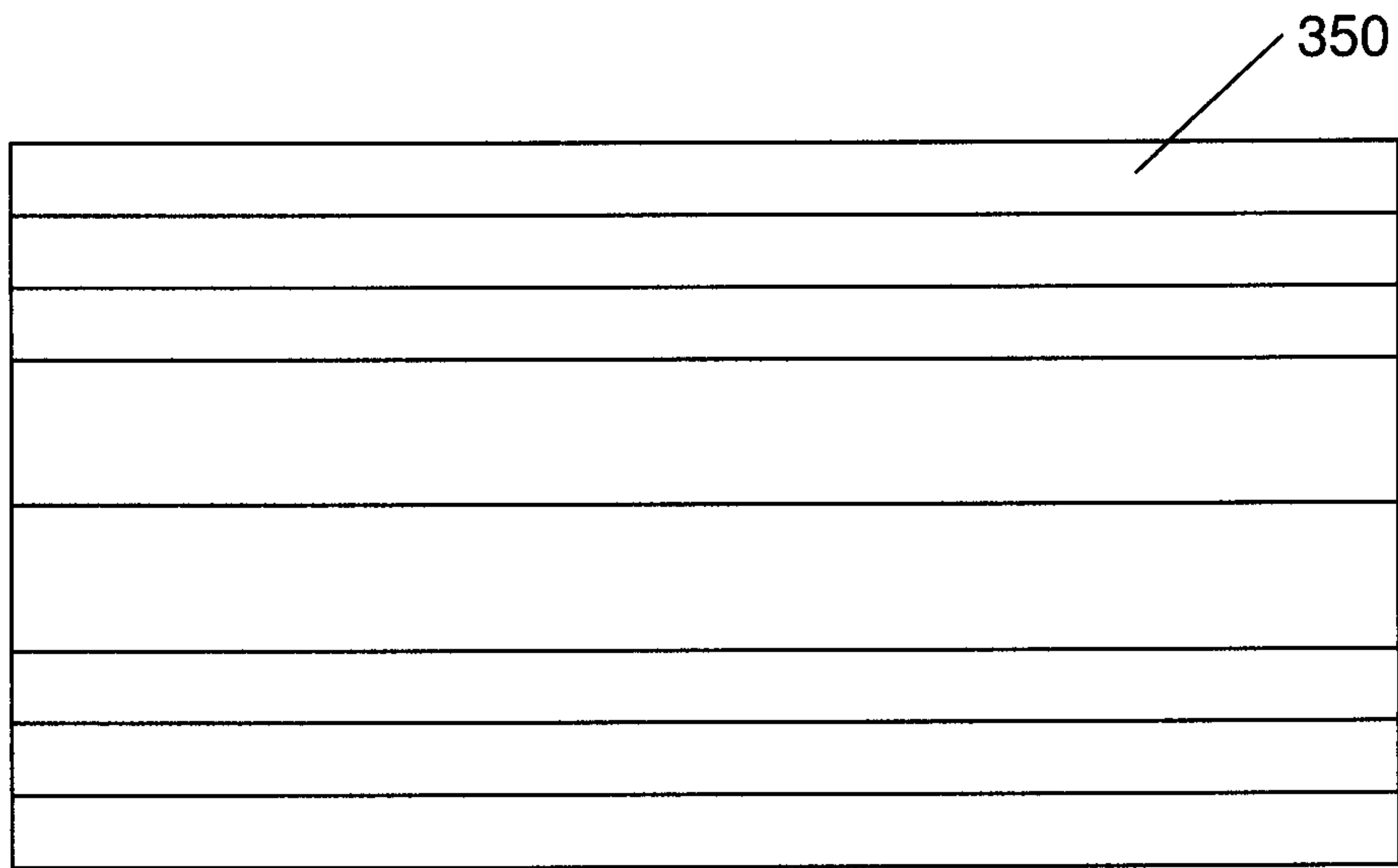

FIGURE 11

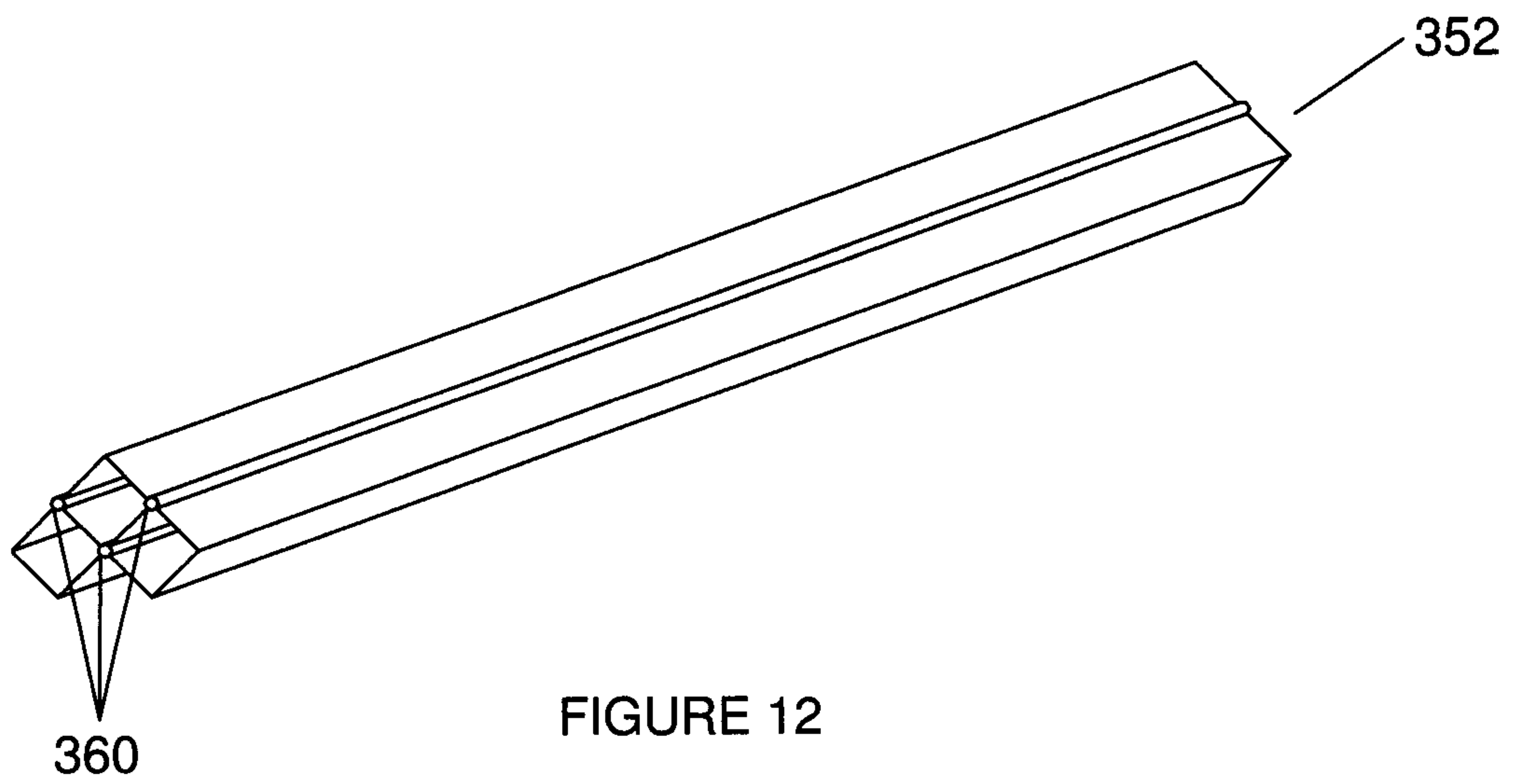

FIGURE 12

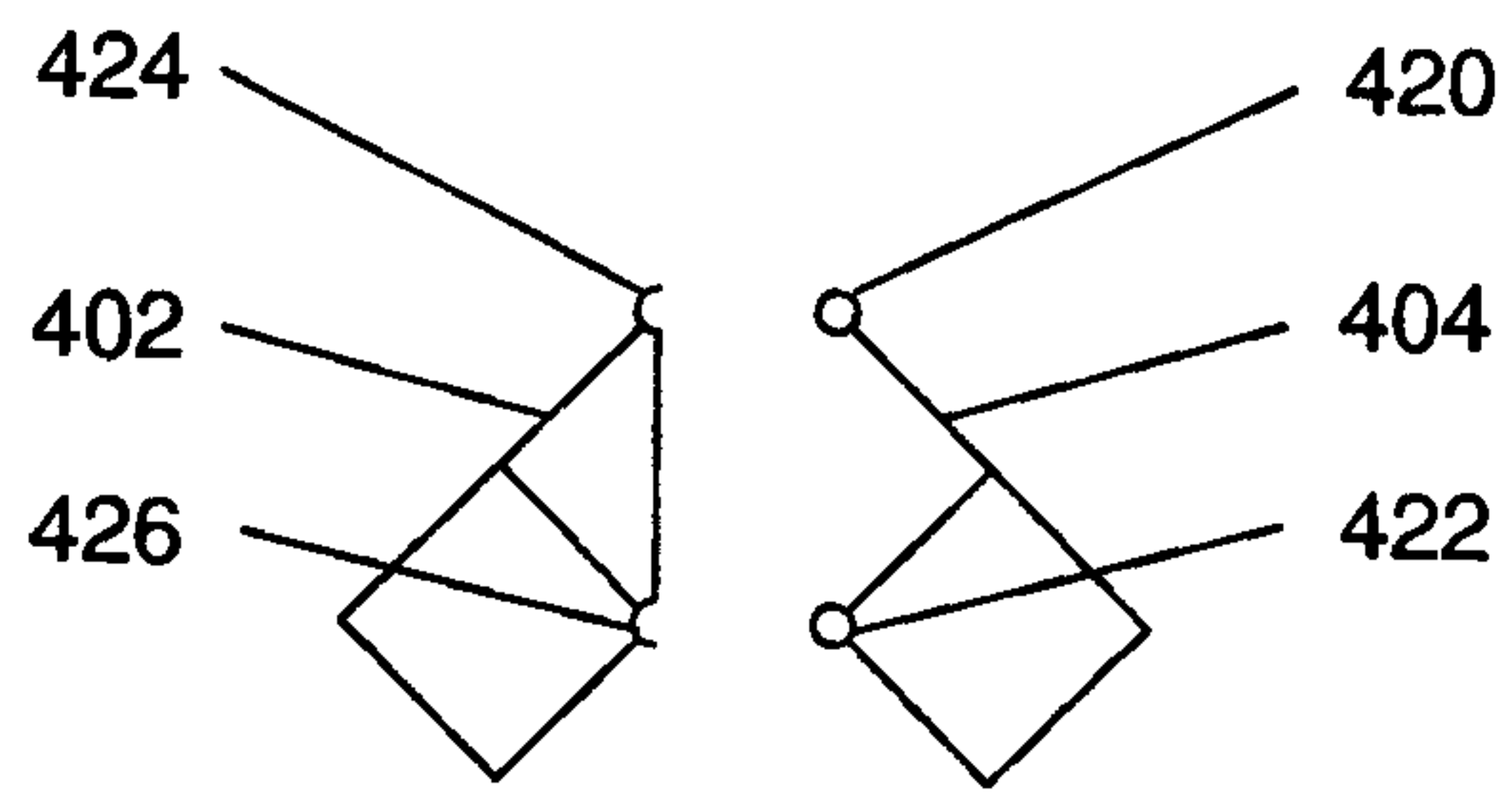

FIGURE 13A

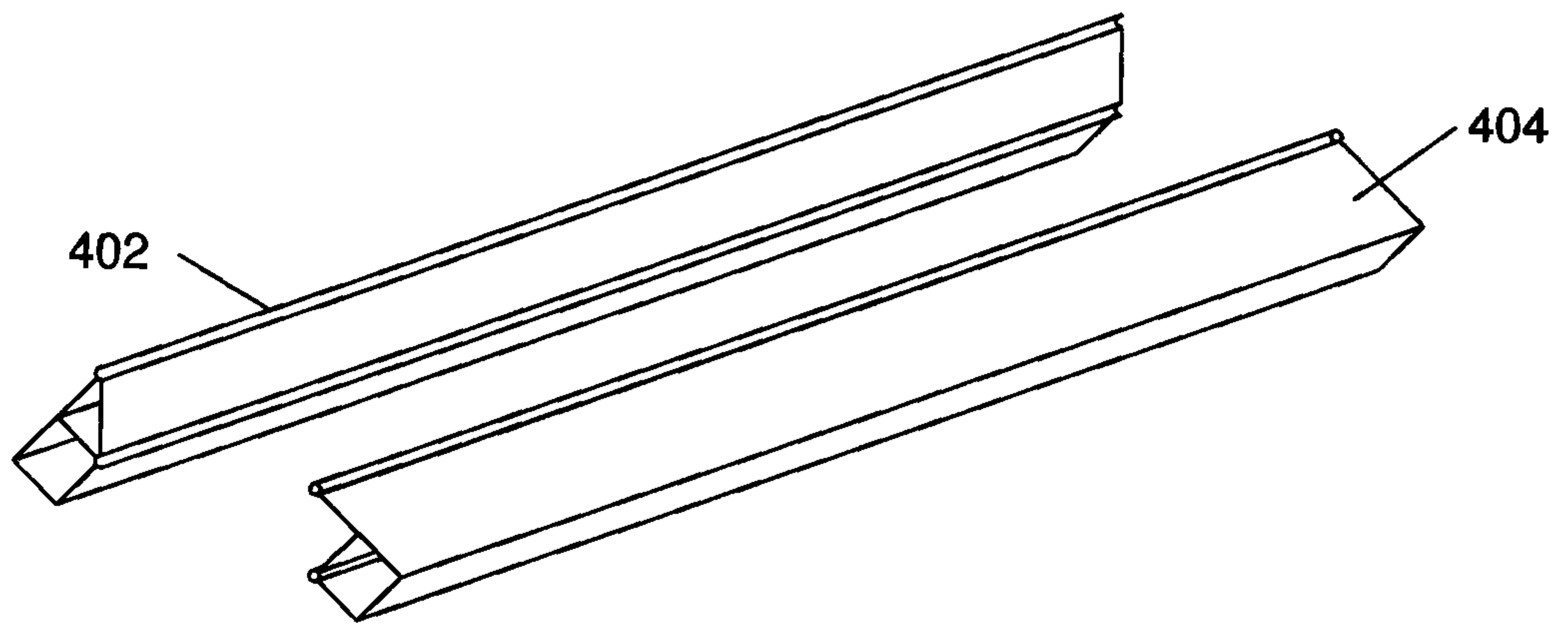

FIGURE 13B

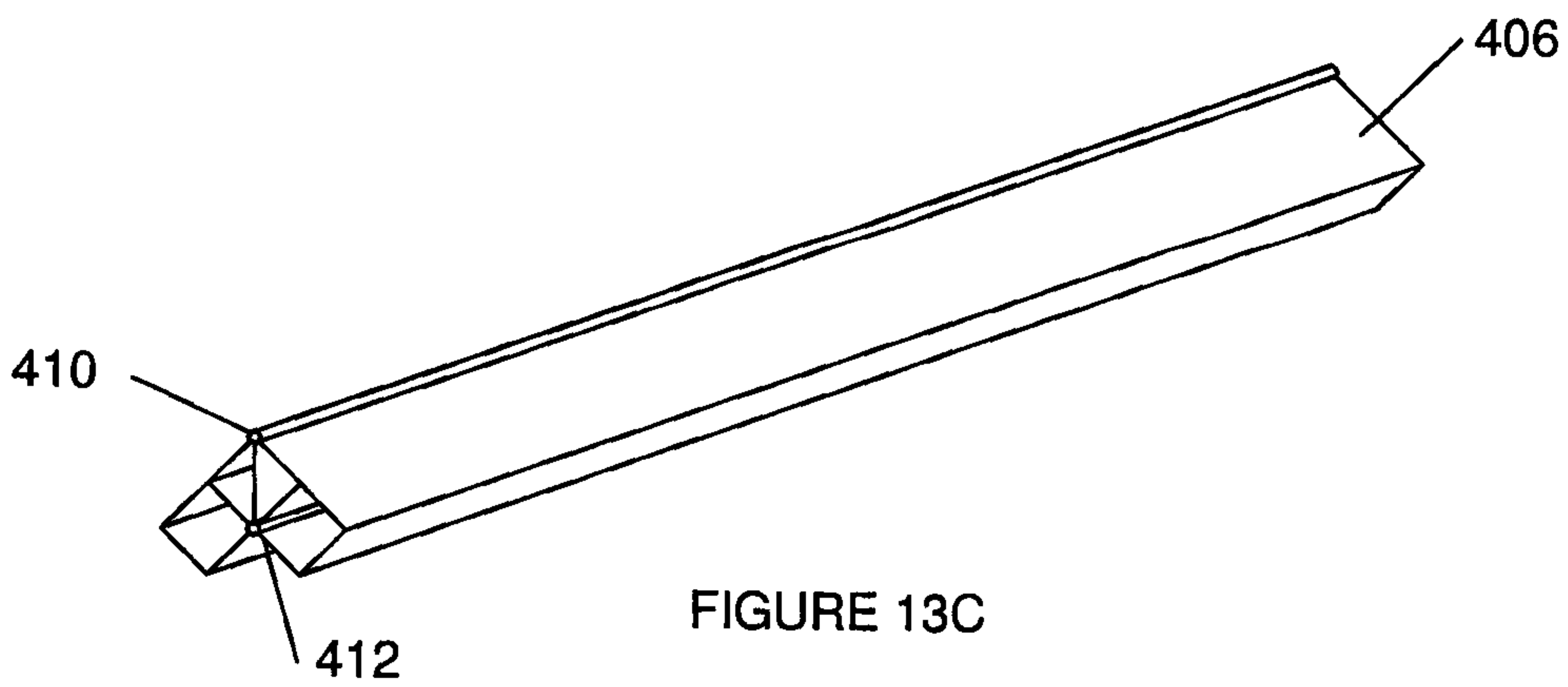

FIGURE 13C

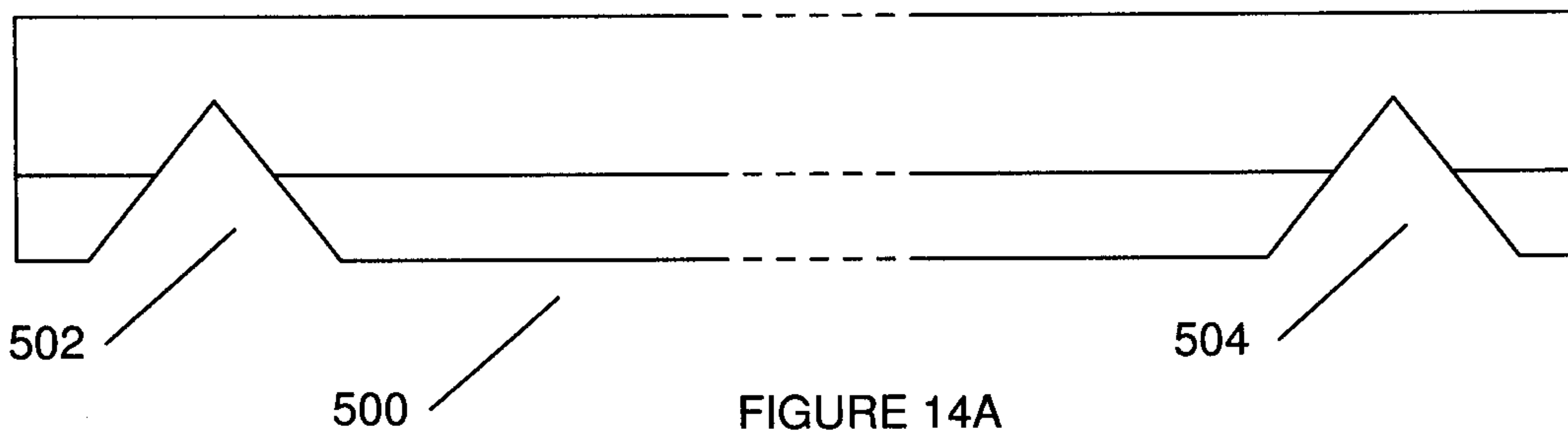

FIGURE 14A

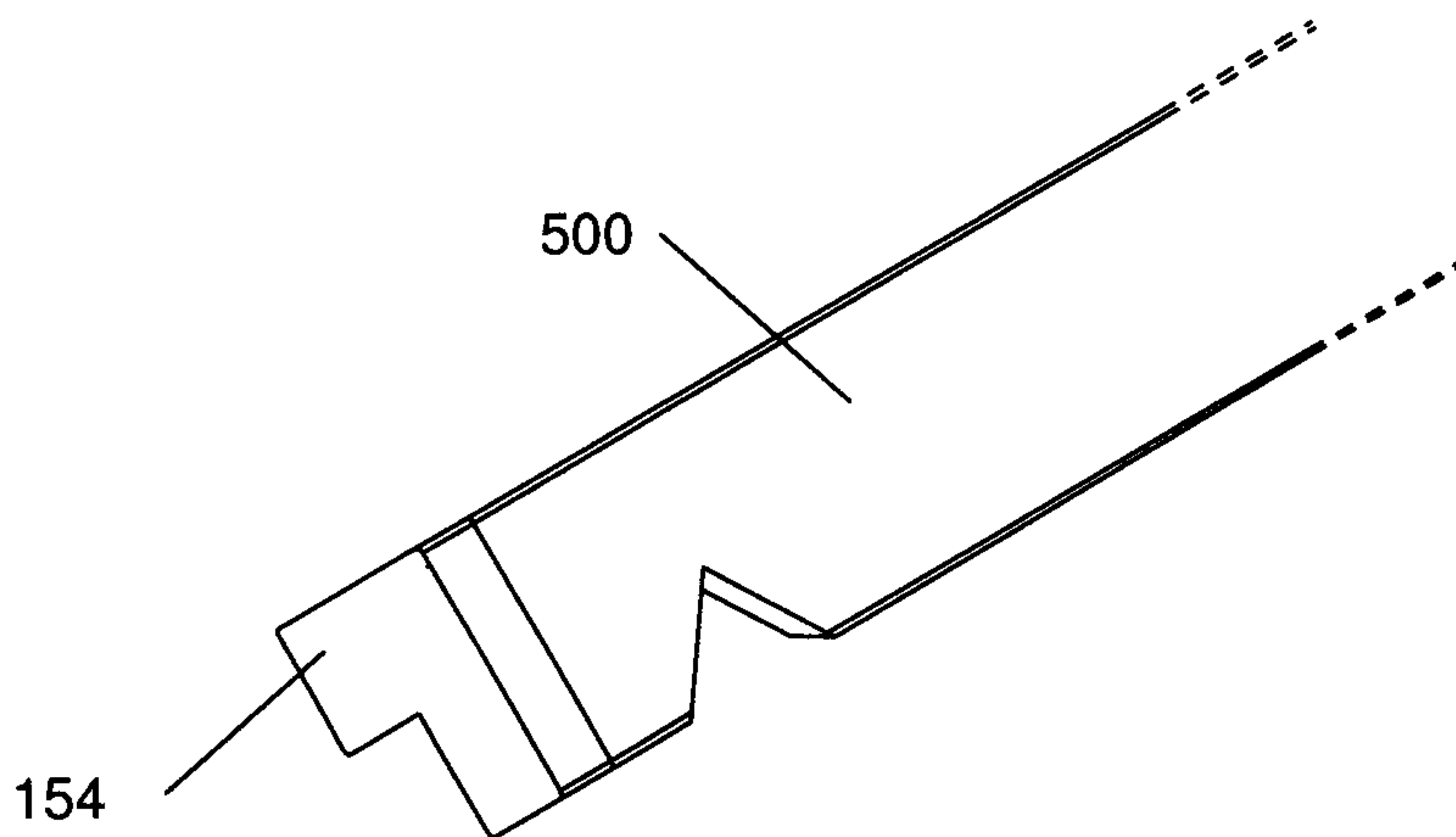

FIGURE 14B

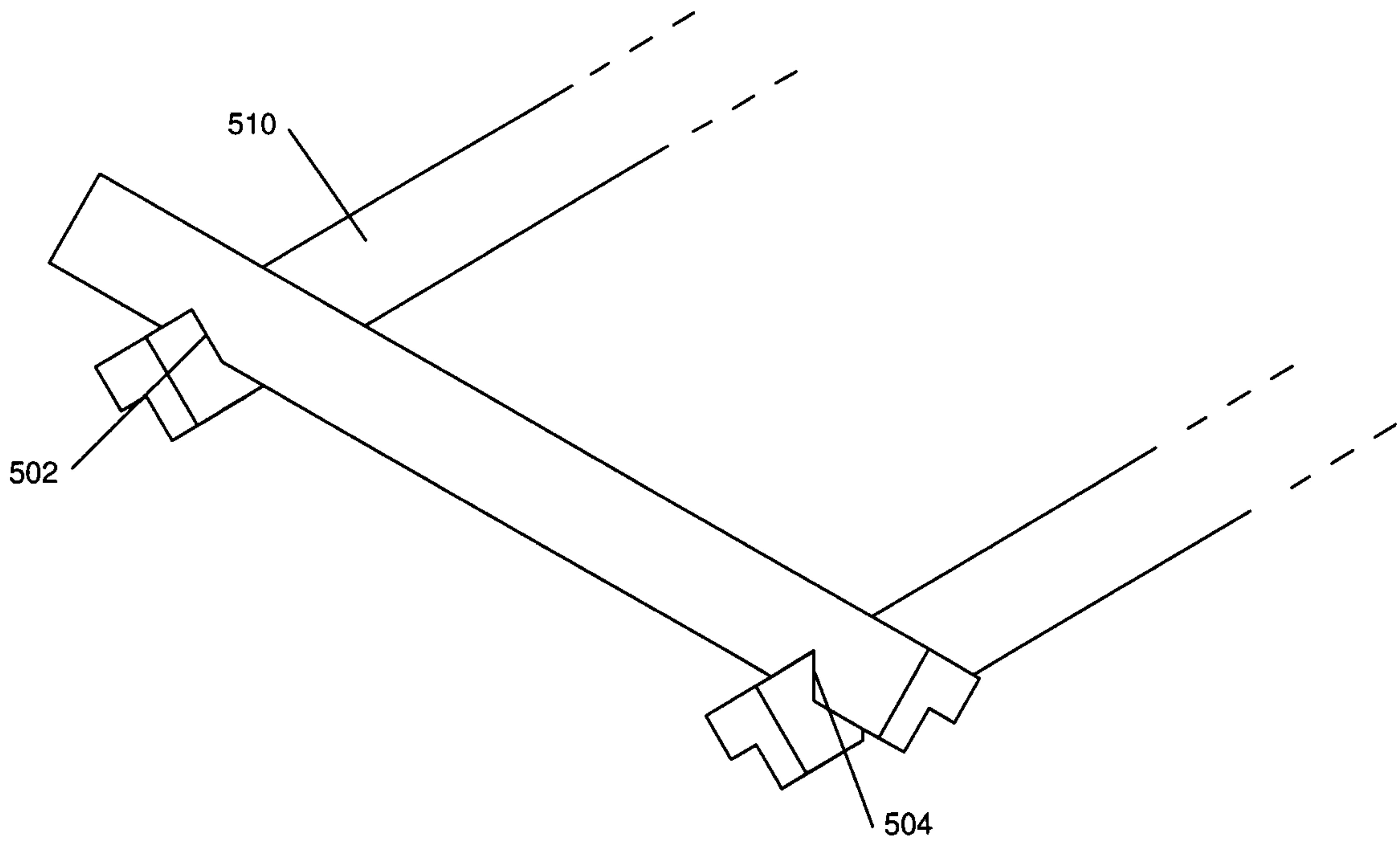

FIGURE 15

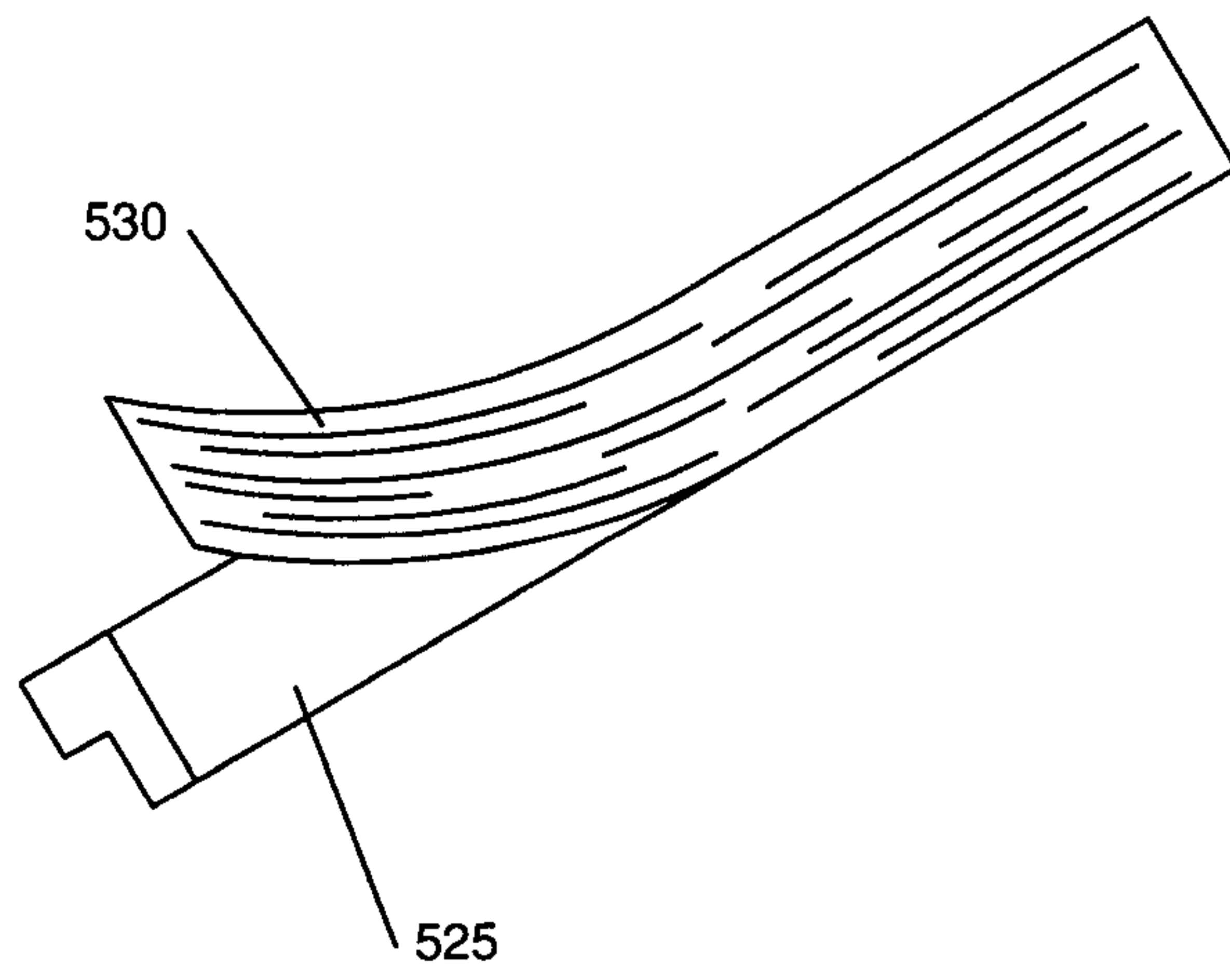

FIGURE 16

