



(19) **United States**

(12) **Patent Application Publication**
Etter et al.

(10) **Pub. No.: US 2014/0287876 A1**

(43) **Pub. Date: Sep. 25, 2014**

(54) **CONTINUOUSLY VARIABLE RESISTANCE EXERCISE SYSTEM**

(52) **U.S. Cl.**
CPC *A63B 24/0087* (2013.01); *A63B 2024/0093* (2013.01)

USPC **482/5**

(71) Applicants: **Dana V. Etter**, Brighton, MI (US);
Thomas A. Etter, Columbus, OH (US);
Robert E. Etter, Fairborn, OH (US);
Roger G. Etter, Delaware, OH (US)

(57) **ABSTRACT**

An exercise system adapted to provide a truly interactive level of exercise with timed exercise intervals that are shown to be optimal in various physiological studies. An example of this invention provides the following unique features: (1) electronically controlled, continuously variable resistance in the positive stroke that responds to the user's efforts and varies the resistance according to the user's current physiological needs; (2) electronically controlled, continuously variable resistance force in the negative stroke that incrementally overcomes the positive muscle contraction and returns to the original position to complete each repetition; and (3) a sophisticated feedback control system that (a) monitors distance, time, and applied force by a user, (b) systematically controls the resistance force to complete each repetition in the specified time intervals, (c) maintains a smooth transition throughout the range of motion, and (d) virtually eliminates the variations of resistance caused by biomechanics, friction, inertia, etc. As a result, an example of the present invention provides the optimum in various types of exercise programs, including but not limited to (1) muscle building, (2) muscle toning, and (3) physical rehabilitation.

(72) Inventors: **Dana V. Etter**, Brighton, MI (US);
Thomas A. Etter, Columbus, OH (US);
Robert E. Etter, Fairborn, OH (US);
Roger G. Etter, Delaware, OH (US)

(21) Appl. No.: **14/218,911**

(22) Filed: **Mar. 18, 2014**

Related U.S. Application Data

(60) Provisional application No. 61/786,865, filed on Mar. 15, 2013.

Publication Classification

(51) **Int. Cl.**
A63B 24/00 (2006.01)

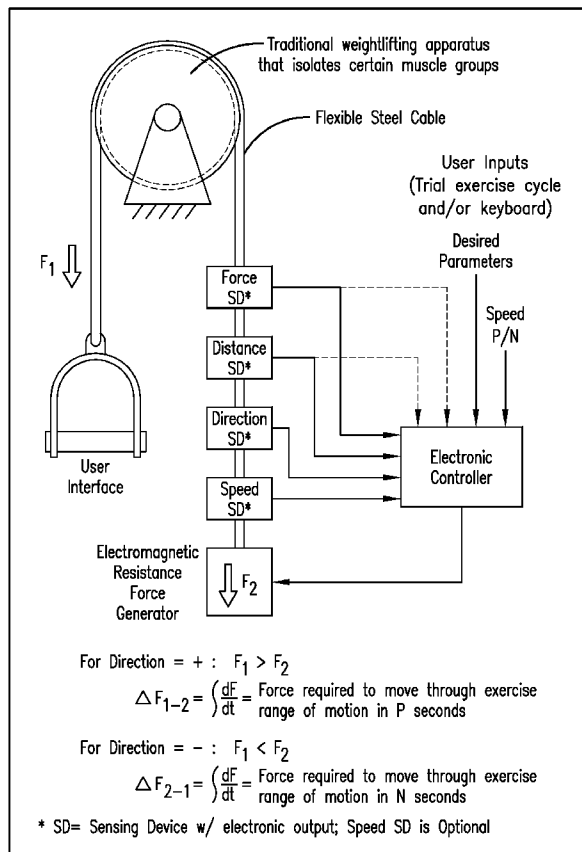

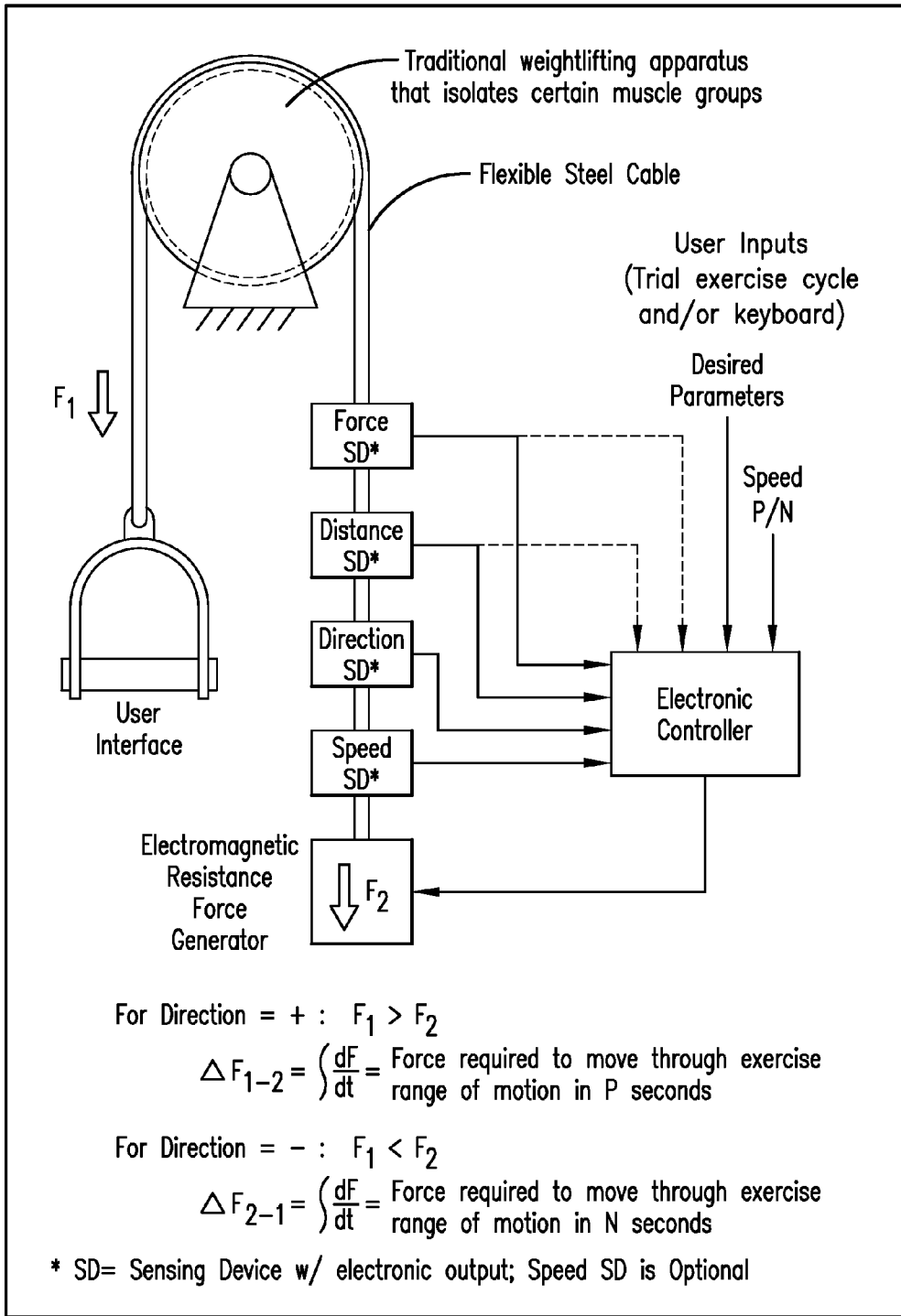

FIG-1

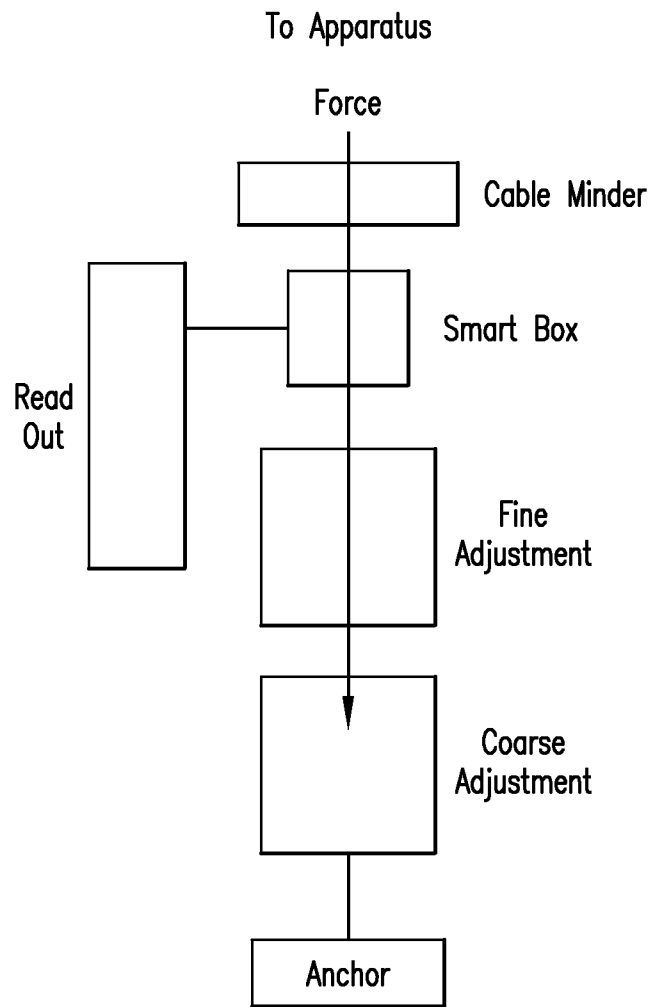

FIG-2

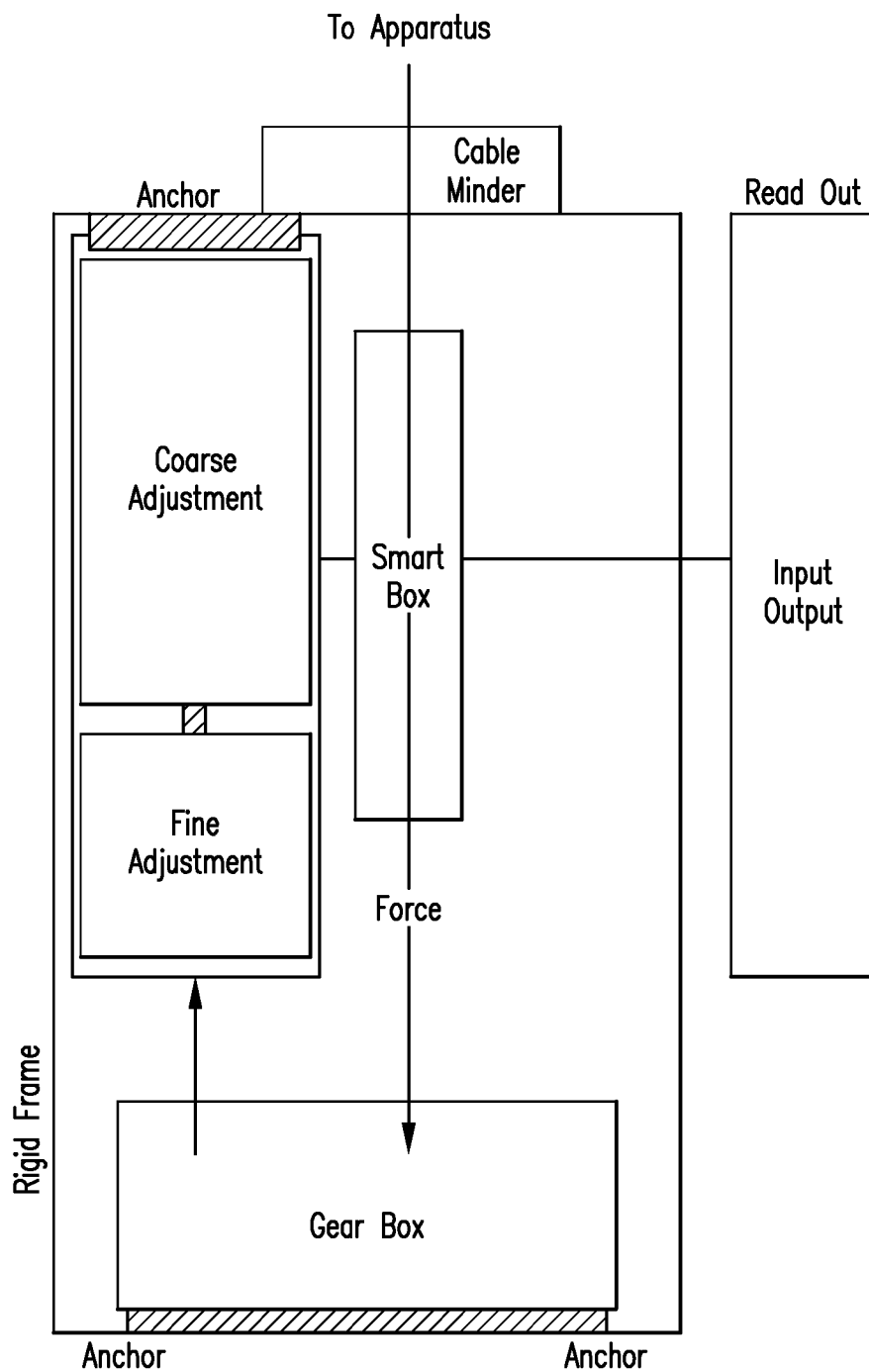

FIG-3

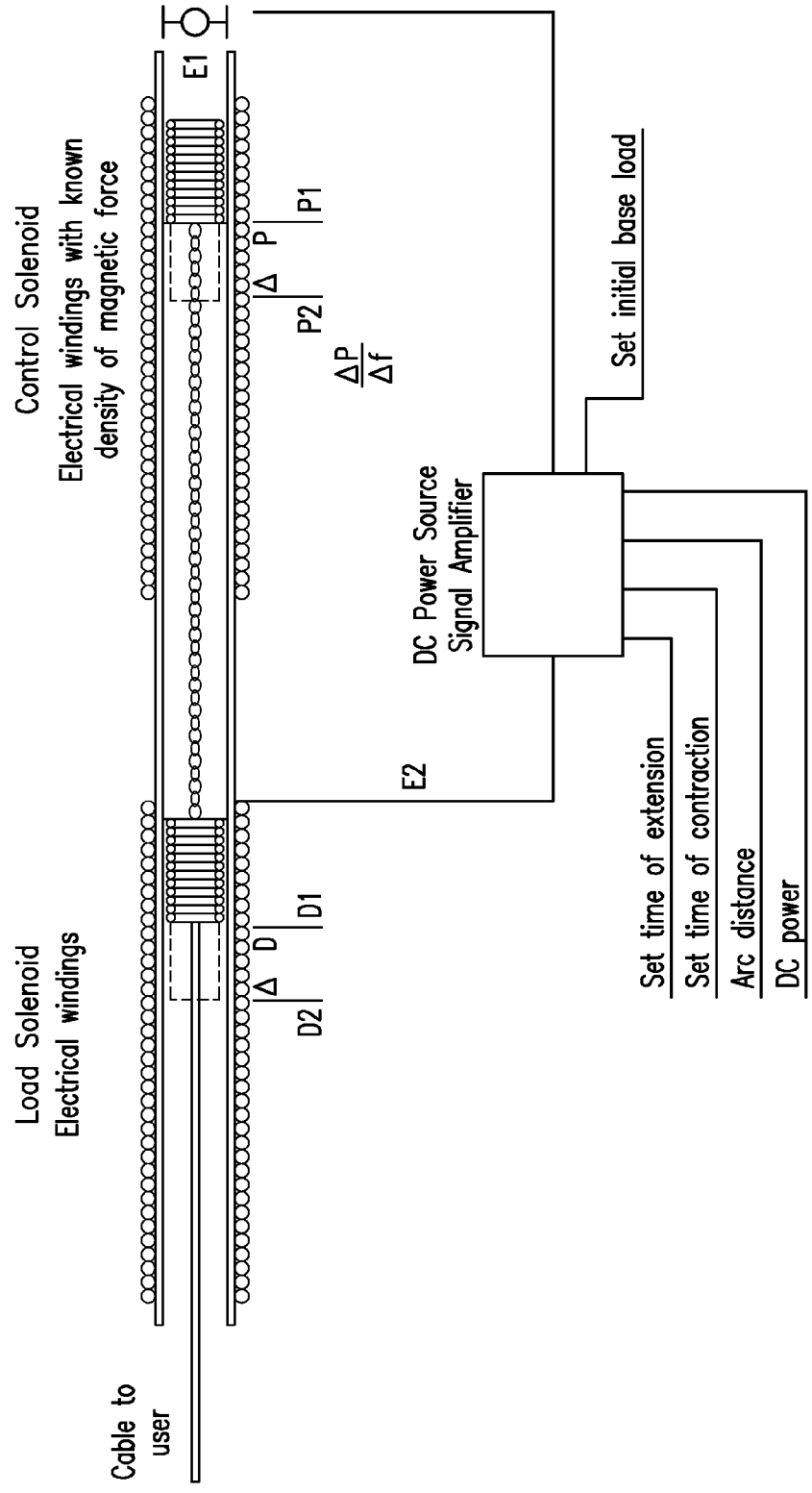

FIG-4

CONTINUOUSLY VARIABLE RESISTANCE EXERCISE SYSTEM

[0001] The present application claims the benefit of U.S. Provisional App. No. 61/786,865, filed Mar. 15, 2013, which is hereby incorporated by reference in its entirety.

BACKGROUND AND SUMMARY OF THE INVENTION

[0002] Exemplary embodiments of the invention relate generally to the field of exercise equipment. More specifically, exemplary embodiments of this invention use electronic control of various types of resistance forces to achieve continuously variable resistance throughout the exercise range of motion and number of repetitions in a unique manner that continuously responds to the force applied by the user.

[0003] A great variety of machines have been developed for exercising various portions of the human body with the primary purpose of building and/or toning certain muscle groups.

[0004] Physiological Studies: Many physiological studies have shown that the building of muscles (i.e. increase in muscle mass or tissue) results from the exhaustion of existing muscle tissues. Additional physiological studies have demonstrated that maintenance of muscle coordination, during muscle development, requires a smooth, controlled transition (vs. jerky) of muscular exercise throughout the primary range of motion, for a particular muscle group. More specific studies have also shown that optimal muscle development occurs with specific time intervals for muscle contractions (concentric contractions) and stressed muscle extensions (eccentric contractions). For example, one of these studies requires the following objectives for optimal muscular development: (1) concentric muscle contractions occur consistently throughout the range of motion for the “positive stroke” over a period of 2 seconds, and (2) muscle extensions (eccentric contractions) occur consistently throughout the range of motion in the “negative stroke” over a period of 4 seconds. From these studies, one could conclude that an exemplary embodiment of an ideal exercise system for muscle building may have the following characteristics:

[0005] 1. Continuously variable resistance that responds to (a) the force exerted by the muscle group and (b) variations of resistance caused by biomechanics, friction, inertia, etc.

[0006] 2. Controlled variable resistance in the negative stroke would incrementally overcome the positive muscle contraction and return to the original position to complete each repetition.

[0007] 3. A sophisticated feedback control system (a) monitors distance, time, and applied force by user, (b) systematically controls the resistance force to complete each repetition in the specified time intervals and (c) maintains a smooth transition throughout the range of motion.

[0008] Another body of physiological studies describes various ways to achieve muscle toning without increasing muscle mass. In general, many of these studies have shown that muscle toning (vs. muscle building) is achieved with less muscle resistance force and more exercise repetitions. This may be achieved by a variety of exercise types (e.g., light dumbbells and/or barbells, resistance bands, kettle bells or body weight, such as calisthenics, etc. From these studies, one may conclude that an example of an ideal exercise system for muscle toning may have one or more of the following characteristics: adjustable, controlled, consistent, and pro-

grammable time, resistance, and distance, (i.e. range of motion), which are easily selected by users with minimal effort and limited knowledge of exercise modalities required.

[0009] Other physiological studies discuss the benefits of various types of exercise programs, including isometric, isokinetic, isotonic, aerobic, anaerobic and combinations thereof.

[0010] Since no exercise system currently provides electronically controlled, continuously variable resistance with timed intervals, the overall benefits of timed intervals in exercise programs are still widely unknown. Further studies will likely flourish once such a system is developed.

[0011] Conventional Weightlifting Systems: In conventional weightlifting devices, the user exercises against a resistance force created by the pull of the earth’s gravity on some type of weight. In its simplest form, the user lifts weights (usually concentric metal weights attached to each end of a metal bar) without restrictions, often called “free weights.” Initial improvements of the free weight system included basic metal racks to guide the weights along a specific path to promote proper weightlifting technique, improve safety, and isolate certain muscle groups. Further modifications have included changes in the mechanics of the weightlifting system (i.e. position of the weight(s) relative to various levers, fulcrums, pulley systems, user interface, etc.) to (1) further isolate muscle groups, (2) improve safety, (3) simplify/reduce costs of certain systems, and (4) normalize the resistance force experienced by the user’s muscles throughout the exercise range of motion. The most significant changes were cam designs (e.g. Nautilus) that reduced the variation of muscle stress throughout the exercise range of motion caused by various body mechanics and other mechanical effects. However, these systems require the user to be the same size as the basis of their design (typically the average-size male) to achieve the full benefits. Most of the current weightlifting machines consist of a stack of flat metal plates connected by a metal cable to various combinations of pulleys, levers, cams, and user interfaces. Typically, the user selects the amount of weight (resistance force) by pushing a metal pin under the lowest plate of the desired weight (marked on the weight stack) and into a hole in a metal rod, that runs through the middle of the weight stack. This metal rod is usually connected to the user interface by a metal cable.

[0012] There are several disadvantages of current weightlifting devices. First of all, none of the present day weightlifting machines has the ability to continuously vary the selected resistance force to achieve the optimal physiological exercise programs described above. The user-selected weight (resistance force) represents, at best, the maximum weight the user can successfully overcome at his weakest point in the positive stroke (of the exercise range of motion) for his last repetition. In addition these systems cannot adjust the resistance downward to compensate for the capability of fatiguing muscles. As a result, exhaustion of the targeted muscle tissues does not occur efficiently, if at all. Secondly, the desirable benefits from the substantially higher resistance forces during the negative stroke of the exercise cannot be achieved on the current weightlifting machines without the assistance of another person, called a spotter. On each positive stroke, the spotter helps the user lift a weight that is heavier than the user could positive lift on his own. The user then resists the negative force of the weight as best he/she can. The positive lifts of this exercise technique have limited benefits due to the inconsistent assistance of the spotter. Consequently, a separate

weightlifting set is usually required. Finally, current weightlifting systems are not capable of monitoring and controlling various aspects of the exercise programs. Most aspects are left to user discretion, including the time intervals for the positive and negative strokes of the exercise repetitions.

[0013] Hydraulic Exercise Systems: Hydraulic exercise systems use compressed fluids or air to apply variable resistance forces in some exercise systems. Hydraulic air systems are commonly referred to as pneumatic exercise systems. Both types of hydraulic exercise systems provide limited ability to vary the resistance to the user in both the positives and negative strokes (or lifts) of the exercise. These hydraulic exercise systems require mechanical linkages for a solid (vs. flexible) force connection to the user interface, making them physically cumbersome. The electronic control of these hydraulic systems is also cumbersome, with limited performance characteristics. Consequently, these systems are expensive, and fall far short of the performance capabilities of the present invention. Additional disadvantages include (1) potential leaks (air/liquid) and air bubbles in liquid hydraulic systems, both resulting in lost resistance force and (2) the need for regular maintenance by trained personnel to insure proper operation.

[0014] Electromechanical Exercise Systems: In recent years, various electromechanical resistance systems have been proposed to replace the conventional weight stack. Such systems not only dispense with the weight stack, but also permit electronic control of the resistance profile during an exercise routine.

[0015] U.S. Pat. No. 4,726,582 Issued on Feb. 23, 1988 to Fulks discloses a programmable exercise system in which conventional weights are replaced by an electric motor and a variable clutch device, such as a magnetic particle clutch. A digital processor is connected to a sensor that detects the position and direction of movement of a user operated member and controls the magnitude of the torque transmitted by the clutch. The resistive force provided to the user is thus varied as a function of the location and direction of movement of the operated member.

[0016] U.S. Pat. No. 5,015,926 Issued on May 14, 1991 to Casler discloses an electronically controlled force application mechanism for exercise systems. This mechanism includes a constant speed, high torque electric (A.C.) drive motor coupled to a dynamic clutch, such as a magnetic particle clutch. The torque and speed of the clutch output shaft is computer controlled to regulate the resistance profile of the exercise system.

[0017] U.S. Pat. No. 5,020,794 Issued on Jun. 4, 1991 to Englehardt et alia also discloses an exercise system in which an electric motor is used to simulate a weight stack. A computer controlled servo loop compensates for friction and inertia within the system and provides for a variable resistance profile during an exercise routine.

[0018] U.S. Pat. No. 5,431,609 Issued on Jul. 11, 1995 to Panagiotopoulos et alia discloses an electronically controlled exercise system that employs a D.C. motor to allow the user to continue to exercise past the point of muscle failure. The user sets the initial weight, and the feedback network adjusts and decreases the resistance as the user progresses through a set of exercises and gradually begins to approach muscle failure.

[0019] U.S. Pat. No. 5,435,798 Issued on Jul. 25, 1995 to Habing et alia discloses an electronically controlled exercise system that employs a motor (A.C. or D.C.) to assist the user during the positive stroke in lifting a suspended mass (the

primary source of resistance). During the return or negative stroke of the exercise, a reduced level of assistance may be provided so that increased negative resistance is experienced by the user.

[0020] In summary, the known art of exercise machines have come a long way from the free weight systems. Prior art has reached a level of electronically controlled variable resistance, but has not yet achieved the truly interactive level with timed intervals demanded by the current trend in physiological studies. Most of the relevant prior art primarily focuses on providing the user with preprogrammed variations of resistance force based on certain underlying assumptions. These exercise systems do not respond to the user's efforts and vary the resistance according to the user's current physiological needs. Furthermore, the prior art does not continually control the weightlifting cycle to assure that the user maintains (1) smooth transitions throughout the range of motion and (2) a consistent timed interval (preset by user or program) for each exercise stroke and/or repetition. Finally, the prior art does not control the user's exercise in a manner that eliminates the detrimental effects of excess momentum, inertia and other mechanical effects.

[0021] An exemplary embodiment of the current invention may successfully provide truly interactive level of exercise with timed exercise intervals, which the prior art has failed to do. This invention provides the following unique features:

[0022] 1. Electronically controlled, continuously variable resistance in the positive stroke that responds to the user's efforts and varies the resistance according to the user's current physiological needs

[0023] 2. Electronically controlled, continuously variable resistance in the negative stroke that incrementally overcomes the positive muscle contraction and returns to the original position to complete each repetition

[0024] 3. A sophisticated feedback control system (a) monitors distance, time, and applied force by user, (b) systematically controls the resistance force to complete each repetition in the specified time intervals, (c) maintains a smooth transition throughout the range of motion, and (d) virtually eliminates the variations of resistance caused by biomechanics, friction, inertia, etc.

[0025] As a result, exemplary embodiments of the present invention are differentiated over the known art and may provide the optimum in various types of exercise programs, including but not limited to (1) muscle building, (2) muscle toning, and (3) physical rehabilitation.

[0026] In addition to the novel features and advantages mentioned above, other benefits will be readily apparent from the following descriptions of the drawings and exemplary embodiments.

BRIEF DESCRIPTION OF THE DRAWINGS

[0027] FIG. 1 shows an example of the present invention in its simplest form. This basic flow diagram shows the basic continuous variable resistance exercise system, comprising (1) Sensor Device(s) for force, distance, direction, and/or speed with electronic output(s) to (2) An electronic controller that receives user inputs (e.g. via trial exercise cycle and/or keyboard), continuously determines desired resistance force F1, and sends control signal to (3) the resistance force generator. Though this example notes an electromagnetic resistance force generator, various types of resistance force gen-

erators may be used, including but not limited to electric (e.g. motor(s), solenoid(s)), pneumatic (e.g. compressed air), and hydraulic.

[0028] FIG. 2 shows a simple block diagram for an exemplary embodiment of the present invention featuring (1) a cable minder (e.g. prevent cable from going slack), (2) smart box that records information from sensor device(s) and user inputs, (3) coarse adjustment device(s) to adjust the base load noted as anchor (e.g. weight) in this diagram, (4) fine adjustment device(s) (e.g. solenoids) to adjust the variable load of resistance force(s), and (5) user interface readout (e.g. computer with monitor) that provides information from smart box to user(s).

[0029] FIG. 3 shows a simple schematic for an exemplary embodiment of similar components as FIG. 2 arranged in a rigid frame to display how these components interact. A gear box is used in this example as a resistance force transfer device.

[0030] FIG. 4 is a schematic view of an exemplary embodiment of a system of the present invention comprising a microchip computer control loop and two functional solenoids.

DETAILED DESCRIPTION OF EXEMPLARY EMBODIMENT(S)

[0031] An original concept for the development of an exemplary embodiment of the current invention may provide the most efficient physiological results for a desired exercise type. Continuous variation of the resistance in response to the user's activities over specified time periods may achieve this benefit in a truly interactive manner. In contrast, the relevant known art focused on providing preprogrammed resistance profiles without regard to the user's actions and/or time duration of strokes.

[0032] An example to illustrate our concept is the maximum development of a certain muscle group (La muscle building exercise type), while maintaining muscle control/coordination throughout the exercise range of motion. Physiological studies have shown that this maximum muscle development would occur with complete muscle exhaustion every other day. Furthermore, the most efficient muscle exhaustion (that maintains muscle coordination) would occur when the traditional lifts are performed with (a) the maximum resistance that a user can continuously exert in the same direction, (b) smooth motions in the forward and negative strokes, and (c) stroke durations of 2 and 4 seconds, respectively. In other words, the ideal physiological exercise machine would require:

[0033] 1. Positive Strokes: Continuous variation of the resistance forces to maintain the maximum resistance the user can exert with smooth transition for 2 seconds duration in each repetition.

[0034] 2. Negative Strokes: Continuous variation of the resistance forces to incrementally overcome the user's ability to maintain the fully contracted position and gradually pull the muscles back to the original, fully-extended position. Maintenance of steady, smooth motion throughout the full range of motion for 4 seconds duration in each repetition.

[0035] As the user's muscle group becomes more exhausted, the continuously variable resistance must gradually decrease with each repetition until complete exhaustion occurs. In conclusion, the ultimate muscle-building exercise machine would (1) automatically adjust the resistance forces to meet these objectives and (2) allow the user to concentrate

only on maximizing the exertion of the desired muscle group in one direction until completely exhausted.

[0036] As illustrated in the above example, the ultimate exercise machine would go beyond preprogrammed resistance profiles. The ultimate exercise machine would allow interactive programming to continuously vary the user resistance forces and timed intervals to provide the optimal and most efficient means to achieve the maximum physiological results for each exercise type. That is, the ultimate exercise machine would also provide the ability to program for other exercise types (i.e. muscle toning, etc.) based on other physiological studies. If properly designed, this continuous variation of the resistance may also overcome many factors previous exercise machines could not, including, but not limited to: (1) differences in size and other physical characteristics of the user; (2) friction, inertia and other factors that make preprogrammed resistance profiles less ideal; and (3) fail-safe operation that minimizes muscle strain when user stops supplying force, etc. Throughout the evolution of exemplary embodiments of the current invention, the pursuit of the ultimate exercise machines with these basic design parameters has remained constant.

[0037] Basic System: Initial development of the basic design concepts focused on a computer-controlled electromagnetic force exercise machine. The process flow chart in FIG. 1 describes the basic system components and interrelationships of the various parts. The electromagnetic force generator could be power solenoid(s) electric motor(s) (e.g. A.C. or D.C.), solenoid activated hydraulic/mechanical system and/or various combinations of these, with or without a gravitational force vector (e.g. weight plates). The electronic controller could range from simple analog devices to very sophisticated digital computers. The force-sensing device could be a tensile force measuring system (e.g. strain gauge), a passive, calibrated solenoid of known EMF density, or similar force measuring devices. Various sensing devices in common practice could be used for sensing distance, direction, and speed. Speed (or velocity) is the derivative of the distance displaced over time. As such the speed-sensing device is not necessary, but recommended to serve as a crosscheck in system performance. Examples of the ideal systems are dependent on application and are discussed below in the "Various Embodiments of the Basic System".

[0038] Conceptually the user would go to the user interface station (i.e. exercise apparatus designed to isolate certain muscle groups) and select the type of exercise program desired: maximum muscle development muscle toning, isotonic, etc. The controller would have preprogrammed parameters for each type. Alternatively, the user could manually select the desirable parameters to define his/her exercise program. Next, the user would input (1) the initial weight that he can lift in the positive stroke and (2) his/her height, weight, and body fat % (optional) to help determine the appropriate distance for the exercise range of motion. On more sophisticated embodiments, the user would simply complete a trial exercise range of motion at his/her maximum exertion level. The sophisticated version of the current invention would determine the initial force and distance as user inputs to the controller from this trial run. After completing these brief preliminaries the user simply focuses on providing the maximum effort from this muscle group in the direction of fully contracted muscles. The current invention will do the rest, assuring the maximum physiological benefits from the desired exercise program. For example, in the case of maxi-

mum muscle development the current invention will provide the most efficient means to achieve complete exhaustion.

[0039] After the exercise program is complete, the controller can provide feedback on the user's performance. If he controller is a digital computer, it can show the actual resistance force profile over time and repetitions. An electronic storage device (e.g. magnetic cards, USB drive) could also be used to store personal information to track progress and avoid manual input of initial parameters. In addition, a slight modification would allow coaches to review individual performance without sacrificing individual privacy. Thus providing the ability to easily adjust, control, and program the various components of a given movement for a specified purpose and result, in a consistent and deliberate manner. Those components being, time, resistance, and distance, as in range of motion.

[0040] The exercise system will interact with the user by means of a physical interface(s) such as a keypad, keyboard, mouse, microphone, and data collecting sensors attached to the user or mechanism itself, or wirelessly, with same. It will also receive from and send information to remote control apparatus and appliances using applications available for wireless devices (e.g. cell phone app).

[0041] More sophisticated embodiments of the present invention would include direct communications (e.g. before, during and/or after the exercise) between the user and the electronic controller (e.g. user input information and controller output information).

[0042] In one embodiment, direct communication with user during exercise can be established by use of a pair of glasses fitted with a viewable screen—(similar to Google glasses)—by wireless connection to base control module. Real-time information such as users force (e.g. equivalent weight being lifted) speed, repetitions, countdown, time, heart rate, and other pertinent statistics can be seen and acted upon by user in real time and used to improve and/or correct exercise activity. In another embodiment, wireless headphones may also be used for workout music played underneath real-time prerecorded encouragement for the completion of repetitions to full exhaustion or to a predetermined goal as well as information such as users force (e.g. equivalent weight being lifted) speed, repetitions, countdown, time, heart rate, and other pertinent statistics can be heard and acted upon by user in real-time and used to improve and/or correct exercise activity. In still another embodiment of the present invention, devices attached to user or to other equipment may also be used to gather other relevant data—such as data gathering belts, bands, or pads—or information collection device (s) used in proximity to user—such as heat, sound or video recorders.

[0043] In addition, it is anticipated that wireless application (s) to interface, control and store personal information will be developed for use with embodiments of the present invention. For example, when used in the performance of resistance exercise, an application would be enabled before user begins work out. Upon approach of selected machine, user will choose (or app would wirelessly recognize) same machine from menu. App will display machine and users past data connected with that machine. App wirelessly (or by corded interface) sets up machine for specific user as directed from passed performance or input from machine screen menu on app (app must collect needed information on first use for future application). App may contain tips or suggestions to improve work out activity. App may record all data created by

work out (weight, reps, time, physiological, etc) wirelessly (or by corded interface) from machine's computer. App may then store all information collected from work out for evaluation, improvement and comparison to future data (and may compare by internet data base to average user of desired physique).

[0044] Exemplary embodiments of the current invention may provide one or more of the following advantages over known art exercise devices:

1. adjustable, consistent, and accurate timing
2. adjustable, consistent, and accurate range of motion
3. adjustable, consistent, and accurate resistance
4. ability to adjust resistance interactively throughout movement based upon automatic and timely measurement of user input
5. ability to program rate of movement within specified intervals of movement in order to replicate and thus train for particular activities or sports tasks
6. ability to programmatically adjust workout according to past performance recorded from prior workouts

Basic System Components:

[0045] User Interfaces: Any device(s) or system(s) that provides (1) communication of user inputs to electronic controller, communication from electronic controller to user, and/or both and (2) exercise medium (e.g. weight lifting station) that interfaces with output of electronic controller/force generator of the present invention. User interfaces include, but should not be limited to:

[0046] (1) keypad(s), keyboard(s), telephone(s), communication glasses, Bluetooth device(s)

[0047] (2) grip, bar, pad, weight lifting station, and/or other exercise station

[0048] Electronic Controller(s): Any device that is capable of being programmed to (1) receive user and/or exercise data/preferences, (2) combine with measured input parameters, (3) calculate the desired resistance force required to achieve the objectives for an embodiment of the present invention, and (4) send a control signal to the resistance force generator in less than 5 seconds, preferably 10-100 milliseconds.

Electronic controllers include, but should not be limited to:

[0049] Digital Microprocessors: computer chips, programmable circuitboards, PC computers, Apple computers, mobile computers, desk top computers, and computer tablets with Graphics Display and Portable Data Storage (e.g. magnetic cards, portable drives, USB drives, etc.)

[0050] Analog Computers: Piezoelectric Cells: Very Cheap Control Mechanism; Ideal for Home systems Assumes constant speed throughout range of motion

[0051] Force Generator System(s): Any device that provides desired force resistance to user that can be controlled electronically in less than 5 seconds, preferably 10-100 milliseconds. One force generator system (e.g. solenoid) can provide sufficient range of resistance for a variable load, while another force generator system (e.g. traditional weights) provides the resistance for a base load. Force generator system(s) include, but should not be limited to:

Large solenoid (e.g. motor); Combine Base Load & Variable Load

Existing Weight Stack (base load) plus solenoid (Variable Load):

Ideal for Some Retrofit Applications

[0052] Base Load Solenoid (e.g., motor) and Variable Load Solenoid

Base Load Electric Motor and Variable Load Solenoid

Various Solenoid Combinations: Series and Parallel

[0053] Force-Sensing Device(s): Any device that measures and electronically transmits in less than 5 seconds, preferably 10-100 milliseconds information relating to (1) a force generated by the user, (2) a force generated by the force generator system(s), and/or (3) both. The information of concern should include, but not be limited to, force, direction of force, distance of movement (e.g. cable) in a period of time, and speed (i.e. distance divided by time). Force-sensing device(s) include, but should not be limited to:

Tensile Force Measuring Systems

[0054] Calibrated Power Solenoid of known EMF Density

Other Embodiments

Isokinetic Exercise System

[0055] A purpose of an exemplary embodiment of this machine may be the replacement of the metal weight system of an exercise machine with a more efficient muscle building or rehabilitation mechanism.

[0056] An example of an ultimate function of an embodiment of this machine is to provide a continuously variable weight from 0-infinity (within mechanical limitations) that will vary itself relative to the force being applied. It may work on one muscle or one set of muscles at a time. (not one muscle and the opposing muscle). It may work on at an optimum speed or time intervals (e.g. 2 seconds to contract, 4 seconds to extend.) As the muscle weakens from exhaustion the weight may decrease relative to the ability of the muscle to maintain the optimum speed through the contraction and extension cycle, e.g. as the muscle weakens it will be lifting less so that it can maintain a 2 second contraction and a 4 second extension.

[0057] In an exemplary embodiment, the force of the muscle(s) may always be applied in one direction, but weight may vary so the muscle will achieve full contraction and then be forced into full extension. This may be achieved by allowing enough resistance (weight) upon the contracting muscle to reach a full contraction in an optimum time. The distance of the contraction would be preset by the subject by computer measurement of one full contraction and extension (or desired distance) before weight is turned on. At the full contraction (or desired contraction) the weight will increase relative to the pressure being applied forcing the muscle(s) into extension (full or desired) in an optimum time. At full extension the machine will reverse itself and allow the muscle to contract with all its power giving enough resistance to assure reaching contraction in the optimum time. At full contraction the machine will again reverse itself and another cycle will be repeated. These cycles of contraction and extension continue at varying amounts of resistance, but at a fixed speed until complete exhaustion or a predetermined resistance are achieved.

[0058] An example of the machine may work by varying the resistance on a DC motor. The motor may act as a circular solenoid rather than a continuous motion motor. the force of the motor will always be in one direction but the controls will allow it to be over powered and turned in the opposite direction although the force is always in one direction. The solenoid (motor) may wind and resist unwinding (or visa versa) of a cable to a spool. This cable may be connected to the weight chain of an exercise machine.

[0059] An example of the control may be adapted to provide and measure the current needed to turn the motor in one direction against a force a given distance in a given amount of time for an expansion cycle, and also provide and measure the amount of current needed to resist a force turning the motor in the other direction a given distance in a given time in a contraction cycle.

[0060] A muscle or group of muscles collaborates to move a part of the body in an arc with a joint as an axis. The arc may be large or small. All or part of this arc may be transversed. The arc will be broken into an infinite number of parts $x0$ to $x\infty$ or $x0$ to $x100$. When the muscles begin their contraction inside the angle of the arc the motor's torque is in one direction but the control allows the motor to be overpowered just enough to let the muscle contract against its resistance at a predetermined speed. On expansion the motor continues to apply force in the same direction but becomes more than muscle can resist and extends muscle at a predetermined speed. The heat that is going to be produced may be taken advantage of such as, for example, by dissipating heat and/or using the heat in another manner.

[0061] To do this, the force of the contraction is measured at each point (100 points for simplicity) relative to the time it took to move from one point to the next. (e.g. The muscle starts its contraction at point 0). The machine may be programmed with a starting resistance (weight) for a particular subject. An example of the contraction may travel through the arc to a full contraction in 2 seconds. If weight is too great, it may take 0.025 seconds. The algorithm may sense this as being too long and lighten the weight so that with same force exerted between point 0 and point 1 muscle will move from point 1 to point 2 in 0.015 seconds. so that the combination of point 0 to point 2 is 0.04 seconds, catching up to scheduled time. If force of muscle increases as angle of arc gets smaller and point 3 is reached in 0.05 seconds. algorithm will sense resistance as to small and make it greater so that from point 3 to point 4 will take 0.03 seconds and total time will be 0.08 seconds. keeping contraction on 2 seconds schedule. Since points would be infinite these changes will continuously vary resistance of motor and a smooth motion will be obtained.

[0062] When contraction reaches point 100, an example of the machine may reverse controls, and the motor may gain force and turn in opposite direction pulling muscle into extension with it. This may be a smooth transition because an example of the motor's force may be in one direction and may be given enough power to overpower muscle instead of muscle over powering motor. A muscle may be extended through the same arc but optimum time changes. In an exemplary embodiment, muscle may trace through the same points in reverse—muscle may still be trying to contract but motor pulls muscle into extension from point 100 to point 99; time is measured and adjustment made from point 99 to point 98 etc. until point 0 is reached and cycle is reversed and repeated.

[0063] As cycles continue subject is using muscles as hard as possible, giving maximum effort at all times. Muscle will

tire—as muscle tires algorithm senses weakening by time taken to move from point to point in arc. Algorithm lessens resistance to allow optimal time for cycles and exercise continues until muscle is totally exhausted or a predetermined level is reached.

[0064] A muscle group and its counter muscle group may be exercised but not at the same time. Each will exhaust itself separately without rest.

[0065] Isotonic Exercise System:

[0066] In an isotonic contraction, tension remains unchanged and the muscle's length changes. Lifting an object at a constant speed is an example of isotonic contractions. A near isotonic contraction is known as Auxotonic contraction. There are two types of isotonic contractions: (1) concentric and (2) eccentric. In a concentric contraction, the muscle tension rises to meet the resistance, then remains the same as the muscle shortens. In eccentric, the muscle lengthens due to the resistance being greater than the force the muscle is producing. Irresistible force against a constant resistance:

[0067] A force "A" moving through a variable, predetermined path and at a variable, predetermined speed—this force is unstoppable (unless turned off by switch or cycle safety interrupt) and is only influenced by the distance traveled and the time to complete the cycle. The time and distance that force A takes to complete its cycle can be varied throughout the cycle but the force will remain the same.

[0068] An opposing resistance of variable force "B"—applied against force A—is moved through same pre-determined path at same pre-determined time even as it continually exerts all of its force in one direction against A at all times.

[0069] A grip—bar—pad—or other add on or replacement device is used to allow force B to pull, push, or twist while interacting with force A—and will be referred to as object "C"

[0070] Object C will contain devices to measure force B performance against constant force A at any time during cycle or any place along path on any section of the object C. The measurements will include speed, time, force, pitch, roll, yaw, prior use, etc. but will not exclude any other pertinent measurable information able to be deduced from force B interaction with force A using Object C.

[0071] Use as an exercise—weight lifting—trainer assist:

[0072] In one embodiment force A would replace the weight stack of any weight machine—its variable distance and speed would allow force B (in this case a muscle force) to pull, push or twist against force A at a predetermined time and/or distance to complete positive and negative stroke of an exercise while force B is always continuous in one direction.

[0073] Object C would replace or be fitted to the object that allows force B to interact with force A (force B in this case is the subject using the machine)—Object C would gather information from the event to be displayed, stored and reused in future to reset, standardize, and compare prior statistics. since Force A is an unstoppable force and moves along a predetermined path—information about force B can be determined anywhere along path and anywhere along object C that a sensor is placed—such as but/not only—the ability to determine the force being produced (e.g. resistance force or equivalent weight being lifted) by both arms and/or individually in a bench press scenario. (one arm will probably be producing more force and one may tire faster than the other—a record of this could be derived with separate sensors for each arm).

[0074] Subject would enter weight machine and be correctly positioned for chosen exercise—speed and time for exercise are set manually or automatically from previous use or a chart.

[0075] Subject moves object C through one repetition: allowing system determine subject's range of motion or range of exercise (it could change from one time to the next). This sets force A path and time.

[0076] On start, force A begins movement of object C—and subject begins applying force (this is force B) opposed to constant force A by way of Object C.

[0077] Object C moves through chosen exercise range of motion in predetermined time. Force A continues to move object C through predetermined path at predetermined time against force B—(If force B is determined not to be present, machine will not operate).

[0078] Exercise continues until a predetermined number of repetitions have occurred—or—resistance B has reached a predetermined level of exhaustion as determined by sensors on Object C or—resistance B is exhausted to 0 as determined by Object C—or—cable goes slack (meaning there is no force B)—or—machine is shut down by subject or operator by kill switch—or—machine is shut down by any of the safety protocol programmed into Object C.

[0079] All data collected by Object C is processed, interpreted, displayed, printed out, and stored for future reference. A and C are reset for next use. Information can be presented to subject on heads up display in real time if desired—or as a read out in glasses worn while exercising—glasses dedicated to each machine or subject owned individual glasses tuned to a different frequency for each weight stack Object C. Glasses would also store all created and necessary information for all different machines along with instructions for use, tips and suggestions for each machine.

[0080] Power Winch Embodiment with Potential Cable Minder:

[0081] An exemplary embodiment may comprise a power source (e.g. power winch), converting energy into motion, a control box—and (in some cases) a cable keeper.

Example One

Illustration Shows Use of a Cable Keeper

[0082] Power torque is always in one direction—by control box it will allow cable to extend at an adjustable distance/time and then will retract cable at an adjustable distance/time. This will be an irresistible force and cannot be overcome by user. By mechanical means the user's effort to resist will always be in a direction opposed to power source. Power source will act as brake as cable extends and as power winch as cable retracts. User will exercise one muscle or one group of muscles at a time to exhaustion (on existing muscle specific machines) by resisting against opposing force. Cable keeper will assure that cable does not go slack at any time while in use or out of use. Control box collects information from cable tension and winch force to store, interpret and display multiple information for user's evaluation, history and self-improvement.

[0083] This appliance may be attached to and replace the weight stack of compatible weight machines or may be a stand-alone unit. When used in conjunction with mechanisms using other than a cable—such as gears, levers, chains, belts, ratchets etc—cable minder would only be needed where there may be a possibility of slack in the force conveyance method.

This appliance could be set up in any form that would allow it to provide a timed, moveable irresistible force against a muscle or set of muscles in one direction.

General Embodiment

Problems to be Solved, Advantages, and Accomplishments

[0084] A. Problems

[0085] Weightlifting has certain rules relative to gaining the best results for your efforts: These rules include the following:

[0086] 1. one should lift on a timed basis

[0087] a. If one lifts too quickly with wild abandon he may create momentum which can carry him past certain parts of his lift. This person will not benefit from these relaxed portions of his lift because certain muscle fibers will not be contracted. He will not experience a full muscle contraction.

[0088] b. If one lifts too slowly, it is difficult to maintain a steady lifting motion without any jerking. Jerking gives muscle fibers momentary rests. Steady lifting is more desirable because it gives you a more intense contraction.

[0089] 2. A variable resistance is very desirable as a muscle comes closer and closer to a dull contraction, it is able to exert more force. When a muscle is in its fully extended position at the beginning of a lift, the weight the muscle can lift is less than its capability in any other position in the lift. Therefore most of the muscle fibers will not reach their full workout potential, unless the resistance (or weight lifted) becomes increasingly greater throughout the lift. The optimum rate of resistance is different for every individual due to the difference in muscles structures of individuals. To achieve the maximum benefit, a weightlifting machine which varies with the individuals efforts is necessary.

[0090] 3. The resistance should be applied in the same direction and against the efforts of the same set of muscles. This is necessary to provide complete exhaustion to the set of muscles which are being exercised. In conventional weightlifting, one extends the muscle (reversing the action of the contraction) by either pulling it down with the use of antagonistic or (opposite) group muscle or relaxing the muscles to allow the gravity force on the weights to overcome this pulling force while providing enough resistance so that the weights don't jerk to their initial position. In both cases, a detrimental rest occurs. For the maximum benefit for a certain set of muscles, it is more desirable to have the exercise machine return to the initial position (extension or reversing the contraction to complete the cycle) in such a way that the person is putting up a maximum effort to redid a force that overcomes his strength. A practice in present weightlifting exercises that demonstrates this concept and its benefit is what is called a negative overload. The common negative overload technique relies on the assistance of several people who help the individual lift a weight greater than he could by himself. Then the individual is left to resist the weight as much as he can by pushing against the force of the excessive weight. However, since the weight is more than he can lift, his

muscles are stimulated to their maximum while the weight comes down. To further maximize the benefit of this type of exercise a smooth (non-jerking) motion is necessary.

[0091] B. Advantages: Unlike conventional weightlifting machines, an exemplary embodiment of the invention entered herewith may have the advantage of effectively creating the opportunity for the maximum benefit in weightlifting by accomplishing all of the rules described above. This exercise machine may accomplish these rules in the qualitative manner described below.

[0092] 1. Lifting on a timed basis: this machine consistently will take two seconds to complete the full range of movement of a particular joint in the forward direction (muscle contraction) and four seconds for the reverse direction (muscle extension) This amount of time has been proven to be optimum for the development of the body by the likes of such research labs as Nautilus. However, this time limit for each direction could be set by the individual according to his needs in the muscle building, toning, or mobility exercises.

[0093] 2. The variable resistance is achieved in a manner that is specific to the individual. The Nautilus weightlifting machine is designed to offer variable resistance but at a set rate in accordance with the cam pulley design. This machine, however, will achieve a variable resistance at a rate that changes with the individual efforts.

[0094] 3. The resistance and pulling forces will be applied in such a manner that the simple set of muscles will work in the same direction at its maximum effort thus exhausting the muscle in a shorter period or time with the maximum benefits.

Other advantages include:

[0095] 1. Capability of computer readout as to work produced by; the muscle before complete fatigue. This will prove beneficial in plotting the progress of the individual and pointing out problem areas in the lift according to strength and endurance.

[0096] 2. Potential of individual's private knowledge of force of lifting. This is an advantage in that often an individual may lift improperly or with improper weights so as to cover his weaknesses. In other words, the need to cheat through competitiveness at weightlifting by improper methodology or excessive weight is eliminated.

[0097] II. Exercise System Development.

[0098] A. Goals:

[0099] Primary goal: The creation of an exercise machine which has the property of continuously varying the load being worked relative to the force applied by the user so that the arc distance of the exercise is moved through in a set fixed time, both in the positive and negative lifting modes.

[0100] Secondary goals: To achieve idealized control and load for exercising with a control system that is programmable to suit the various needs of its users.

[0101] B. Control Mechanism: With the above goals in mind, the optimum means of achieving the most desirable aspects of exercising appears at the present to be a microprocessor-computerized control of an electric DC continuous motor. For the simplicity of explanation, however, the DC continuous will be separated into its functional parts, which are very similar in operation to two separate solenoids; the control solenoid and the load

solenoid. A simplistic diagram of the microchip computer control loop and the two functional solenoids is given as follows and shown in FIG. 4:

[0102] where ΔP =the distance the steel core in the solenoid moved as a result of the user force

[0103] ΔD =the distance the steel core in the load solenoid moves as a result of both the user force and the electric force of resistance

[0104] E_1 =the electromotive force generated by the movement of the control solenoid core through the windings

[0105] E_2 =the altered electromotive force output of the control system

[0106] The operation of this control mechanism involves a basic premise that the electronic circuit will match the force by individual and add or subtract resistance in the extension or contraction periods, respectively. The amounts of resistances to be added or subtracted will depend on the set times selected for the contraction and extension and the arc distance.

[0107] Basically, the system will work in the following manner:

[0108] 1. The individual chooses the exercise station appropriate for the set of muscles he would like to work on and approach this station.

[0109] 2. He would set the initial base load from which to start. Though this selection is nominal the closer the individual selects the force in accordance with what he can initially lift, the quicker the control system will settle into the optimum control range (i.e. the dynamic response will be that much shorter)

[0110] 3. The individual would then set the periods of time he desires for his contraction and extension in accordance with the type of exercising desired. If the individual does not adjust the times the computer will assume two seconds for the contraction and four seconds for the extension.

[0111] 4. The individual will then set the arc distance by simulating the motion of the exercise to be done. For example, if arm curls are desired, he would push a button for arc distance measurement, signaling the machine to record the distance of cable pulled. As he goes through the exercise motion, the arc distance it the exercise is measured and used as a set point in the computer system.

[0112] 5. Next, the individual begins his exercise contracting his muscles with maxim effort.

[0113] 6. The exercise machine will effectively divide the arc distance into many segments approaching infinity yet limited by the time of the electric pulse through the control loop. For the sake of simplicity of explanation, we will use 100 segments for this discussion. Therefore, the arc will be divided into 100 points. Let's label them X0 to X100. As the individual starts the exercise, he pulls against the base load from X0 to X. In doing so, he moves the steel core (with wire windings) in the control solenoid a certain corresponding distance. The power to this solenoid will be fixed with the density of magnetic force from the solenoid windings being known. Therefore, as the core passes a certain distance for a given period of time, a certain electromotive force will be produced. The current produced will be delivered to the microprocessor.

[0114] 7. This current is altered to produce a current in the windings of the load solenoid to create the desired mechanical resistance. The altered current will depend on the following factors:

[0115] a. contraction or extension periods

[0116] b. the set time for the part of the exercise cycle in "a"

[0117] c. arc distance

[0118] d. the calibration of the l; pad solenoid windings in accordance with mechanical resistance provided by current through these windings.

[0119] 8. In this manner, the load solenoid causes an increase resistance on the user almost instantaneously by increasing E_2 from what it was in the base load. The increased current then causes greater resistance in the steel core.

[0120] 9. In continuing, the user then polls the control solenoid from X1 to X2 and the control loop repeats in the same manner through the expansion.

[0121] 10. During the contraction the same mechanism occurs but in the reverse direction and the motor is actually supplying the work to move the exercise machine.

[0122] During the contraction period, E_2 would be altered to produce a mechanical resistance such that it would effectively match equal the force supplied by the individual and then subtract the force necessary for the exercise equipment to go through the arc distance in the set time for contraction. Ideally this subtracted force will remain constant for a particular individual throughout a certain exercise. In this regard the general force balance would be as follows:

[0123] where F_1 =the force supplied by the user

[0124] F_2 =equally matched resistance by motor

[0125] F_3 =the force required to move the machine through the arc in T seconds

[0126] and mathematically

$$F_1 = F_2 - F_3 = F_4$$

[0127] where F_4 =the ultimate motor resistance

$$F_1 - F_4 = R_1 = F_3$$

[0128] the force supplied exceeds the motor resistance by a force necessary for arc traverse

[0129] Similarly, during the contraction period, E_2 is altered to produce a mechanical force exceeding the force supplied by the individual by the amount of force necessary to reverse traverse the arc in 4 seconds

$$F_1 - F_2 = F_3$$

[0130] where F_1 =the force supplied by the user

[0131] F_2 =the equally matched resistance by the motor

[0132] F_3 =the force required to move the machine through the arc in 4 seconds and mathematically;

$$F_1 = F_2 + F_3 = F_4$$

[0133] where F_4 =the ultimate motor resistance or force

$$F_4 - F_1 = R_2 = F_3$$

What is claimed is:

- 1. An exercise system comprising:
user interface(s), force sensing device(s), electronic controller(s), force generating device(s), or any combination thereof;
said user interface(s) and said force sensing device(s) adapted to provide information to said electronic controller(s);
said electronic controller(s) adapted to convert said information to a continuously variable control signal for said force generating device(s); and
said force generating device(s) adapted to provide variable resistance to a user such that muscle contraction and muscle extension are completed in user specified time intervals;
wherein said system is adapted to allow said user to exert force in one direction through desired repetitions and optimally exercise an isolated muscle or muscle group.
- 2. A system of claim 1 wherein said user interface(s) comprise grip(s), bar(s), pad(s), other exercise station(s), keypad(s), keyboard(s), telephone(s), communication glasses, or any combination thereof.
- 3. A system of claim 2 wherein:
said communication glasses comprise glasses that have communication capabilities to transfer data from said microprocessor to said user; and
said communication glasses are selected from the group consisting of Google glasses, Apple glasses, or any combination thereof.
- 4. A system of claim 2 wherein said telephone(s) comprise landline or portable telephone(s) that have communication capabilities to transfer data from said user to said microprocessor or vice versa.
- 5. A system of claim 1 wherein said force sensing device(s) comprise any device(s) adapted to measure and electronically transmit in less than 5 seconds, preferably 10-100 milliseconds information relating to (1) a force generated by the user, (2) a force generated by the force generator system(s), or (3) any combination thereof.
- 6. A system of claim 1 wherein said force sensing device(s) comprise tensile force measuring systems, calibrated power solenoids of known EMF density, or any combination thereof.
- 7. A system of claim 1 wherein said electronic controller(s) comprise any device(s) adapted to be programmed to (1) receive user and/or exercise data/preferences, (2) combine with measured input parameters, (3) calculate a desired resis-

tance force, and (4) send a control signal to the resistance force generator in less than 5 seconds, preferably 10-100 milliseconds.

8. A system of claim 1 wherein said electronic controller(s) comprise digital microprocessors, analog computers, piezoelectric cells, or any combination thereof.

9. A system of claim 6 wherein said electronic controller(s) have graphic display(s), portable data storage device(s), or any combination thereof.

10. A system of claim 9 wherein said portable data storage device(s) comprise magnetic cards, portable drives, USB drives, or any combination thereof.

11. A system of claim 8 wherein said digital microprocessors comprise programmable computer chips, programmable circuit boards, PC computers, Apple computers, mobile computers, desk top computers, computer tablets, or any combination thereof.

12. A system of claim 1 wherein said force generating device(s) comprise any device adapted to provide force resistance to said user that can be controlled electronically in time intervals less than 5 seconds, preferably 10-100 milliseconds.

13. A system of claim 1 wherein said force generating device(s) comprise motor(s), solenoid(s), power winch(es), engine(s), hydraulic system(s), pneumatic system(s), or any combination thereof.

14. An exercise system comprising:

user interface(s), force sensing device(s), electronic controller(s), force generating device(s), force modification device(s) or any combination thereof;

said user interface(s) and said force sensing device(s) adapted to provide information to said electronic controller(s);

said electronic controller(s) adapted to convert said information to a continuously variable control signal for said force generating device(s); and

said force generating device(s) provide variable resistance to said user such that muscle contraction and muscle extension are completed in specified time intervals;

wherein said system is adapted to allow said user to exert force in one direction through desired repetitions and optimally exercise an isolated muscle or muscle group.

15. A system of claim 14 wherein said force modification device(s) comprise any device adapted to increase or decrease said force resistance to said user via mechanical means

16. A system of claim 14 wherein said force modification device(s) comprise gear box(es), pulley system(s), sprocket & chain system, or any combination thereof.

* * * * *