



(51) International Patent Classification:

A61F 15/00 (2006.01) A61F 13/02 (2006.01)
A61F 13/00 (2006.01)

MAIOLI, Alessandro; Piazzale Marcolini, 63, 25010 San Zeno Naviglio (BS) (IT). CARTAPANI, Stefano; Via San Gaetanino, 21, 25123 Brescia (BS) (IT).

(21) International Application Number:

PCT/IB2018/060443

(74) Agent: AUTUORI, Angelo; c/o Eureka IP Consulting, Via Monte Cengio, 32, 36100 Vicenza (IT).

(22) International Filing Date:

20 December 2018 (20.12.2018)

(81) Designated States (unless otherwise indicated, for every kind of national protection available):

AE, AG, AL, AM, AO, AT, AU, AZ, BA, BB, BG, BH, BN, BR, BW, BY, BZ, CA, CH, CL, CN, CO, CR, CU, CZ, DE, DJ, DK, DM, DO, DZ, EC, EE, EG, ES, FI, GB, GD, GE, GH, GM, GT, HN, HR, HU, ID, IL, IN, IR, IS, JO, JP, KE, KG, KH, KN, KP, KR, KW, KZ, LA, LC, LK, LR, LS, LU, LY, MA, MD, ME, MG, MK, MN, MW, MX, MY, MZ, NA, NG, NI, NO, NZ, OM, PA, PE, PG, PH, PL, PT, QA, RO, RS, RU, RW, SA, SC, SD, SE, SG, SK, SL, SM, ST, SV, SY, TH, TJ, TM, TN, TR, TT, TZ, UA, UG, US, UZ, VC, VN, ZA, ZM, ZW.

(25) Filing Language:

Italian

(26) Publication Language:

English

(30) Priority Data:

102017000147076 20 December 2017 (20.12.2017) IT

(71) Applicant: ISINNOVA SRL [IT/IT]; Via Cefalonia 55, 25124 Brescia (BS) (IT).

(72) Inventor; and

(71) Applicant: STORARI, Alberto [IT/IT]; Via Monco 15, 37024 Negrar (VR) (IT).

(84) Designated States (unless otherwise indicated, for every kind of regional protection available):

ARIPO (BW, GH, GM, KE, LR, LS, MW, MZ, NA, RW, SD, SL, ST, SZ, TZ, UG, ZM, ZW), Eurasian (AM, AZ, BY, KG, KZ, RU, TJ,

(72) Inventors: FRACASSI, Cristian; Via Papa Giovanni XXIII, 20, 25020 Bassano Bresciano (BS) (IT). RO-

(54) Title: RIGID OR SEMI-RIGID PROTECTING ELEMENT FOR COVERING WOUNDS

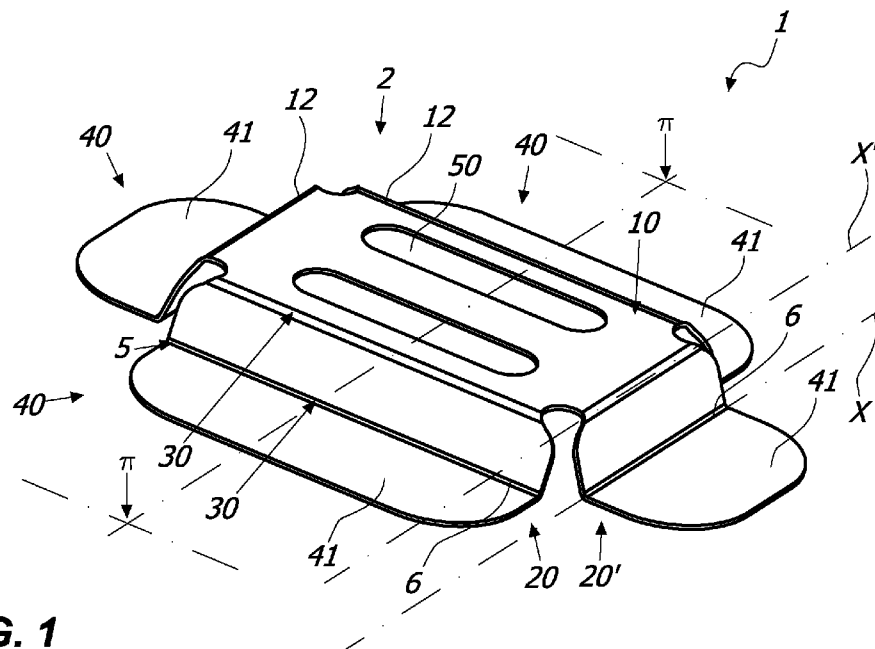

FIG. 1

(57) Abstract: A protecting element for wounds comprising: at least one rigid or semi-rigid substantially concave covering portion (2) susceptible to remain facing the wound (F) and spaced apart the latter and anchoring means (40) of the covering portion (2) to the skin surrounding the wound (F) to protect. In particular, the anchoring means (40) comprise at least one pair of movable fins (41) independently to each other, whereas each fin (41) is rotatably coupled with the covering portion (2).



WO 2019/123376 A1

TM), European (AL, AT, BE, BG, CH, CY, CZ, DE, DK, EE, ES, FI, FR, GB, GR, HR, HU, IE, IS, IT, LT, LU, LV, MC, MK, MT, NL, NO, PL, PT, RO, RS, SE, SI, SK, SM, TR), OAPI (BF, BJ, CF, CG, CI, CM, GA, GN, GQ, GW, KM, ML, MR, NE, SN, TD, TG).

Published:

- *with international search report (Art. 21(3))*
- *in black and white; the international application as filed contained color or greyscale and is available for download from PATENTSCOPE*

RIGID OR SEMI-RIGID PROTECTING ELEMENT FOR COVERING WOUNDS**DESCRIPTION**Field of the Invention

5 The present invention relates to a protecting element, and in particular it concerns an element for the protection of a skin area of a person, comprising a wound.

Background of the invention

It is known that in case of wounds, abrasions, excoriations or the like, it is necessary to protect the latter from dirt or infections, and at the same time it is necessary to prevent the clothing worn by a person from getting dirty because of the wound itself.

10 For this purpose, different types of elements for the protection of wounds to apply to the skin of the person, such as for example patches are well known. They comprise an adhesive part susceptible to be glued with the skin and a non-adhesive part susceptible to come into contact with the wound.

15 The patches, however, do not protect the wound from shocks, and coming into contact with the wound prevent it from recovering quickly.

For this purpose, rigid devices to be interposed between the wound and the bandage are well known to prevent the latter to come into contact with the same wound.

Some examples of such devices are known from US2004/127838, US4972829, US3976066 and US6110197.

20 Such known devices are poorly adaptable to the different morphology of the various areas of the human body, in particular to the curved areas, with the risk of being ineffective, annoying and/or with the risk of detaching easily.

Summary of the invention

25 Object of the present invention is to overcome, at least partially, the drawbacks illustrated above, by providing a protective element for wounds with a high functionality.

Another object of the invention is to provide a protecting element for wounds particularly inexpensive to make.

Another object of the invention is to provide a protecting element for wounds that is adaptable to different parts of the human body.

30 Such objects, as well as others that will be clearer hereinafter, are fulfilled by a protecting element for wounds according to what is herein described, shown and/or claimed.

The dependent claims define advantageous embodiments of the invention.

Brief description of the drawings

Further features and advantages of the present invention will become more evident by reading the detailed description of some preferred but not exclusive embodiment of a protecting element **1**, illustrated as a non-limiting example, with the help of the annexed drawings, wherein:

FIGs. 1, 2, 3, 4, 7 and 8 are axonometric views of different embodiments of a protecting element **1**;

FIGs. 5 and 6 are schematic side views of different applications of an embodiment of the protecting element **1**;

FIG. 9a is an axonometric view of a further embodiment of the protecting element **1**;

FIG. 9b is a view of the embodiment of the protecting element **1** of FIG. 9a wherein the front area and rear area **20'** have been removed;

FIG. 10 is an axonometric view of a further embodiment of the protecting element **1**.

Detailed description of some preferred embodiments

With reference to the above mentioned figures, it is here described a rigid or semi-rigid protecting element for wounds **1**, which is susceptible to be anchored to the skin area of a person surrounding the wound **F** to protect.

It is understood that, even though hereinafter we will generally refer to a wound **F**, the protecting element may be equally used in case of abrasion, excoriation, infection, furuncle, acne, burn, tattoo or any similar event requiring protection and/or dressing, without departing from the scope of the invention defined in the appended claims.

As better explained below, the protecting element **1** may be configured so as, once it is applied to the skin of the person, the wound **F** does not come into contact with clothing or bandages, both to protect the wound and to prevent clothing or bandages from getting dirty due to blood, pus or medicaments.

The present invention comprises several similar or identical parts and/or elements. Where not otherwise specified, similar or identical parts and/or elements will be indicated with a single reference number, meaning that the technical characteristics described are common to all the similar or identical parts and/or elements.

The protecting elements **1** may comprise or may consist of a single laminar element in

rigid or semi-rigid polymeric material, which may preferably be in optically transparent or translucent polymeric material. For example, such material may be polyethylene terephthalate (PET) or Polyvinyl Chloride (PVC).

5 The protecting element **1** may comprise at least one covering portion **2** substantially concave susceptible to remain facing the wound **F** and spaced apart the latter. It is understood that the concavity may be therefore facing the wound **F**.

In particular, the covering portion **2** may remain spaced apart the wound **F** and may present a plurality of base edges **5** susceptible to come into contact with the skin, preferably in a peripheral area with respect to the wound **F** itself.

10 The covering portion **2** may comprise an upper area **10** substantially planar or slightly curved and a plurality of peripheral areas **20**, **20'**, each extending from the former in order to connect it to the respective section **6** of the respective base edge **5**.

In particular, the covering portion **2** may comprise a couple of peripheral areas **20**, preferably equal to each other, and possibly a couple of front and rear areas **20'**, preferably equal to each other as well.

For example, the embodiment shown in FIGs. 1 to 9b comprises both the peripheral areas **20** and the front and rear areas **20'**, whereas the embodiment shown in Fig. 10 comprises the peripheral areas **20** only.

20 The peripheral areas **20** and the front and rear areas **20'** may be substantially integral to each other, for example as shown in Fig. 3, or they may be interspersed with one or more discontinuities so as to be movable in a substantially independent manner, for example as shown in Figs. 1 and 2.

Possibly, the peripheral areas **20** and the front and rear areas **20'** may be connected by connecting elements **21**, which may be selectively removed by the user or by the operator according to requirements.

25 According to a particular aspect of the invention, each peripheral area **20** and, if present, front and rear areas **20'** may be rotatably coupled with the upper area **10** in at least one section **12** thereof.

30 In particular, the section **12** of the upper area **10** may define the longitudinal axis **X'** acting as a reciprocal rotation axis between the same upper area **10** and the respective peripheral **20** or front or rear area **20'**.

In the embodiments shown in Figs. 1 to 9b comprising both the peripheral areas **20** and the front and rear areas **20'**, the upper area **10** may have four sections **12** which substantially define the perimeter thereof.

5 On the other hand, the embodiment shown in Fig. 10 which comprises only the peripheral areas **20** may comprise a pair of sections **12** facing each other.

Preferably, the upper area **10** may have an elongated shape in order to define a main development axis **Y**. Possibly, the upper area **10** may have a substantially polygonal plan shape, preferably but not exclusively a substantially rectangular plan shape.

10 According to a particular preferred but not exclusive embodiment of the invention, the upper area **10** may be substantially planar or slightly curved in order to define a plane π and may be facing the wound **F** and spaced apart the latter thanks to the peripheral areas **20**, **20'**.

Suitably, anchoring means **40** may be provided for anchoring the covering portion **10** to the skin surrounding the wound **F** to protect.

15 In particular, the anchoring means **40** may comprise at least one pair of fins **41**, which may be movable independently to each other. Preferably, the fins **41** may be arranged on opposite sides with respect to the covering portion **2**, in correspondence of the peripheral areas **20**.

20 According to a particular aspect of the invention, the fins **41** may have an upper face **42** at sight and a lower face **43** susceptible to come into contact with the skin. In order to secure the fins **41** to the skin of the user, a bandage, a gauze, one or more patches or similar may be provided.

Advantageously, each fin **41** may be rotatably coupled with the covering portion **2** in correspondence of the base edges **5** to reciprocally rotate.

25 In particular, the fins **41** may be rotatably coupled with the base edge **5** in at least one section **6** thereof.

The section **6** may define a longitudinal axis **X** acting as a reciprocal rotation axis of the fin **41** and of the covering portion **2**. Suitably, the longitudinal axis **X** and the longitudinal axis **X'** may be substantially parallel to each other.

30 Such configuration allows to cover wounds **F** located in any position of the human body, even in the presence of curves or articulation. The independent mobility of the fins **41**,

indeed, will allow an excellent anchoring of the covering element **1** independently from the configuration of the area surrounding the wound **F** to cover.

For example, in case the protecting element **2** is anchored to the elbow, it may be allowed to bend the arm, avoiding the same protecting element **2** annoys and/or hinders the movement and avoiding the detaching from the skin of the same protecting element **2**.

Such extreme adaptability is also allowed by the intrinsic flexibility of the polymeric material of which the covering element **1** is made of, which is flexible when needed, in order to adapt to the morphology of the area surrounding the wound **F**, but which nevertheless allows to always keep the upper area **10** spaced apart the latter of a height **h**.

Moreover, the possibility of rotation of the peripheral areas **20**, and if present **20'**, allows to reduce or to increase this height **h**, depending on requirements. For example, it may be possible to increase this height **h** in case particular bulky dressings are necessary, or it may be possible to reduce it in order to limit the bulkiness or the discomfort of the same protecting element **1**.

Suitably, the lower face **43** may be adhesive. For example, in a per se known manner, an adhesive tape coupled to the same lower face may be provided, otherwise a layer of glue or similar may be provided.

Possibly, a layer of adhesive material may be provided, such as an adhesive gauze, arranged on the lower faces **43** of the fins **41**. In this manner, on the one hand it may be possible to promote the adherence of the protecting element **1** to the skin, and on the other hand it may be possible to make the contact between the protecting element and the skin itself more comfortable, in particular between the fins **41** and the skin.

Suitably, the covering portion **2** may comprise one or more sacrificial areas selectively separable therefrom.

In a preferred but not exclusive embodiment of the invention, such sacrificial areas may be defined by one or more of the peripheral areas **20** or front or rear areas **20'**.

For example, in Fig. 7 two protecting elements **1** are shown, where the front area has been removed **20'**. In this manner, it is possible to juxtapose or overcome the protecting elements along the axis **Y**, so as to cover wounds of any length.

On the other hand, in Fig. 9b a protecting element **1** is shown, where the front and rear areas have been removed **20'**, which are visible for example in Fig. 9a.

In such a situation as well, it is possible to juxtapose or overcome the protecting elements along the axis **Y**, so as to cover wounds of any length.

It is understood that it is possible to make the peripheral areas **20** removable, independently from the possibility to remove the front and rear areas **20'**. In other words,
5 the peripheral areas **20** and/or the front and rear ones **20'** may define the sacrificial areas.

In this manner, it is possible to juxtapose or overcome the protecting elements both along the axis **Y** and in a direction perpendicular thereto, so as to cover any size of the wound **F**.

In a further embodiment shown in Fig. 10, the covering portion **2** may consist of a
10 plurality of sections modularly placed side by side **2'**, all equal to each other, each defining a respective sacrificial area. In this case, the removal of one or more sacrificial areas **2'** may allow to selectively change the size of the protecting element **1**, and in particular the length thereof, considered along the axis **Y**.

For example, the latter may be sold with a predetermined number of sections, and its
15 length may be reduced according to requirements, by removing one or more sacrificial areas or sections **2'**.

It is understood that the covering portion **2** may have even just one part made of sections, for example the central part, and removable continuous areas, for example the front and rear ones, as shown in Figs. 9a and 9b.

It is furthermore understood that the sacrificial areas **2'** may be of any size, not
20 necessarily equal to each other.

Therefore, it is clear that, thanks to the above mentioned characteristics, it may be possible to change the configuration of the protecting element according to the shape, size and/or location of the wound **F** to protect.

In order to facilitate the removal of the sacrificial areas, each of the latter may be
25 operatively connected with the remaining part of the covering portion **2** by a separation line which comprises weakening means **30** of the laminar element of which the protecting element is made.

The separation lines may for example be the sections **12** in the embodiments shown
30 in Figs. 1 to 8 or the edges **12'** in the embodiments shown in Figs. 9a to 10.

The weakening means **30** may be of a per se known type. For example, they may be

defined by a thinning of the covering portion **2** in correspondence of the separation lines, and/or by a plurality of passing through holes aligned along the latter.

Thanks to this features, it may be possible to reciprocally separate in a controlled manner the sacrificial areas of the remaining part of the covering portion **2** by acting along
5 the respective separation line, for example by tearing or pulling.

Possibly, as shown in Fig. 2, stopping means **25**, preferably of the removable type, may be provided in order to restrain the peripheral areas **20**, **20'** in an operative position so as even after shocks and/or bandages the protecting element **1** does not collapse, i.e. the upper area **10** remains spaced apart the wound **F**.

10 For example, the stopping means **25** may be fins to connect two adjacent peripheral areas **20**, **20'** so as to prevent the rotation with respect to the upper area **10**.

On the other hand, the peripheral areas **20** and, if present, the front and rear areas **20'** may be disconnected from each other, so as to allow the maximum reciprocal independent mobility. In other words, the peripheral areas **20** and, if present, the front and
15 rear areas **20'** may be exclusively connected with the upper area **10** in correspondence of the respective sections **12**, whereas they may be disconnected from each other.

According to a particular aspect of the invention, the covering portion **2** may comprise at least one hole **50** passing therethrough in order to allow the ventilation of the wound **F** and or the introduction of catheters, needles or similar. In particular, the holes **50**
20 may be arranged on the upper area **10** and/or on one or more peripheral areas **20**, **20'**.

Suitably, the protecting element **1** may comprise at least one closing element **60** which may be coupled with the upper area **10** and/or the peripheral areas **20** in order to close one or more passing through holes **50**. Preferably, the closing element **60** may be selectively removable by the user or by the operator, so as to allow a better ventilation of the
25 wound **F**, according to requirements.

For example, a longitudinal passing through slot **50** or a couple of slots **50** placed on the upper area **10** and a sheet shaped element **60** of equal shaping coupled with the upper area **10** through two sacrificial points, may be provided.

According to another aspect of the invention, identification elements may be
30 provided, for example in order to simply and quickly identify the size of the protecting element **1** or the intended use or other similar characteristics. The identification elements

may be for example an embossed code, a writable area or the like, and they may be arranged in correspondence of the upper area **10** so as to be easily visible by the user or the operator. On the other hand, the identification element may be a R-FID tag, possibly embedded in the laminar element of which the protection element **1** is made.

5 Advantageously, as shown in Fig. 8 an adhesive element **80** may be provided in order to promote the adherence of the protective element **1** to the skin. In particular, the adhesive element **80** may have a substantially rectangular shape and it may have a central hole **81** so as to remain in correspondence of the faces **42** of the fins **41**, i.e. only in correspondence of the peripheral areas **20**, so that the upper area **10** remains substantially transparent.

10 According to a particular aspect of the invention, the protecting element **1** may be made by thermoforming or injection moulding or by blanking and bending of a polymeric material sheet, so as to obtain the laminar element.

In this way the production costs of the protecting element **1** may be particularly low.

15 Moreover, according to a particular embodiment, the whole protecting element **1** may comprise the adhesive layer so as to simplify and speed up the processing operations.

The invention is susceptible to numerous modifications, all falling within the scope of protection of the attached claims. All the details may be replaced with other technically equivalent elements and the materials may be different according to requirements, without departing from the scope of the invention defined in the appended claims.

CLAIMS

1. A protecting element for wounds (F) comprising or consisting of a single laminar element of substantially rigid or semi-rigid polymeric material which includes:

- at least one substantially concave covering portion (2) comprising:

- 5
- an upper area (10) substantially planar or slightly curved susceptible to be faced to the wound (F) and spaced apart the latter;
 - at least one pair of base edges (5) susceptible to come into contact with the skin surrounding the wound (F);
 - at least one pair of peripheral areas (20) each extending between said upper area (10) and a respective base edge (5);
 - 10 - at least one passing through hole (50) so as to allow the ventilation of the wound (F) and/or the introduction of catheters;

- at least one pair of fins (41) each extending from a respective base edge (5) for anchoring (40) said at least one covering portion (2) to the skin surrounding the wound (F) to protect, each fin (41) comprising a lower face (43) susceptible to come into contact with the skin and an opposite upper face (42);

15

wherein said at least one covering portion (2) comprises at least one sacrificial area (20, 20'; 2') selectively separable therefrom so as to allow the variation of the configuration of the protecting element according to the shape, size and/or position of the wound (F) to protect.

20

2. Protecting element according to claim 1, wherein said at least one sacrificial area (20, 20'; 2') is operatively connected to the remaining part of said at least one covering portion (2) by at least one separation line (12; 12') that includes weakening means (30) of said laminar element, so as to allow the reciprocal guided separation thereof by action along said at least one separation line (12; 12').

25

3. Protecting element according to claim 2, wherein said weakening means (30) comprise a thinning of said laminar element in correspondence of said separation line (12; 12') and/or a plurality of passing through holes aligned along the latter.

4. Protecting element according to one or more of the preceding claims, wherein said upper area (10) has a substantially elongated shape in order to define a main development axis (Y).

30

5. Protecting element according to one or more of the preceding claims, wherein said upper area (10) has a substantially quadrangular plan shape, preferably rectangular.

6. Protecting element according to claim 4 or 5, wherein said at least one covering portion (2) comprises or consists of a plurality of sections (2') modularly placed side by side, each defining a respective sacrificial area, said sections (2') being preferably equal to each other, the removal of one or more of said sections (2') allowing to selectively modify the size along said main development axis (Y).

7. Protecting element according to claim 4, 5 or 6, wherein said peripheral areas (20) are facing each other and extend in a substantially parallel manner to said main development axis (Y), a pair of front and rear areas (20') extending in a substantially perpendicular manner to said peripheral areas (20) being provided, at least one of said peripheral areas (20) and/or front and rear areas (20') defining said at least one sacrificial area, the removal of the latter allowing to juxtapose or overcome two or more protection elements along said main development axis (Y) and/or perpendicularly thereto.

8. Protecting element according to one or more of the preceding claims, wherein the lower face (43) of each fin (41) is adhesive.

9. Protecting element according to one or more of the preceding claims, wherein each fin (41) is rotatably coupled with the respective base edge (5) in at least one first section (6) thereof defining a first axis (X) for the reciprocal rotation of the fin (41) and the respective peripheral area (20).

10. Protecting element according to the preceding claim, wherein each of said peripheral areas (20) is rotatably coupled with said upper area (10) in at least one second section (12) of the latter (10) defining a second axis (X') for the reciprocal rotation of said upper area (10) and the respective peripheral area (20), said first and second rotation axis (X, X') being substantially parallel to each other.

11. Protecting element according to one or more of the preceding claims, further comprising at least one closing element (60) coupled with said at least one passing through hole (50) so as to protect the latter, said at least one closing element (60) being selectively removable by a user or an operator.

12. Protecting element according to one or more of the preceding claims, wherein said polymeric material is optically transparent or translucent.

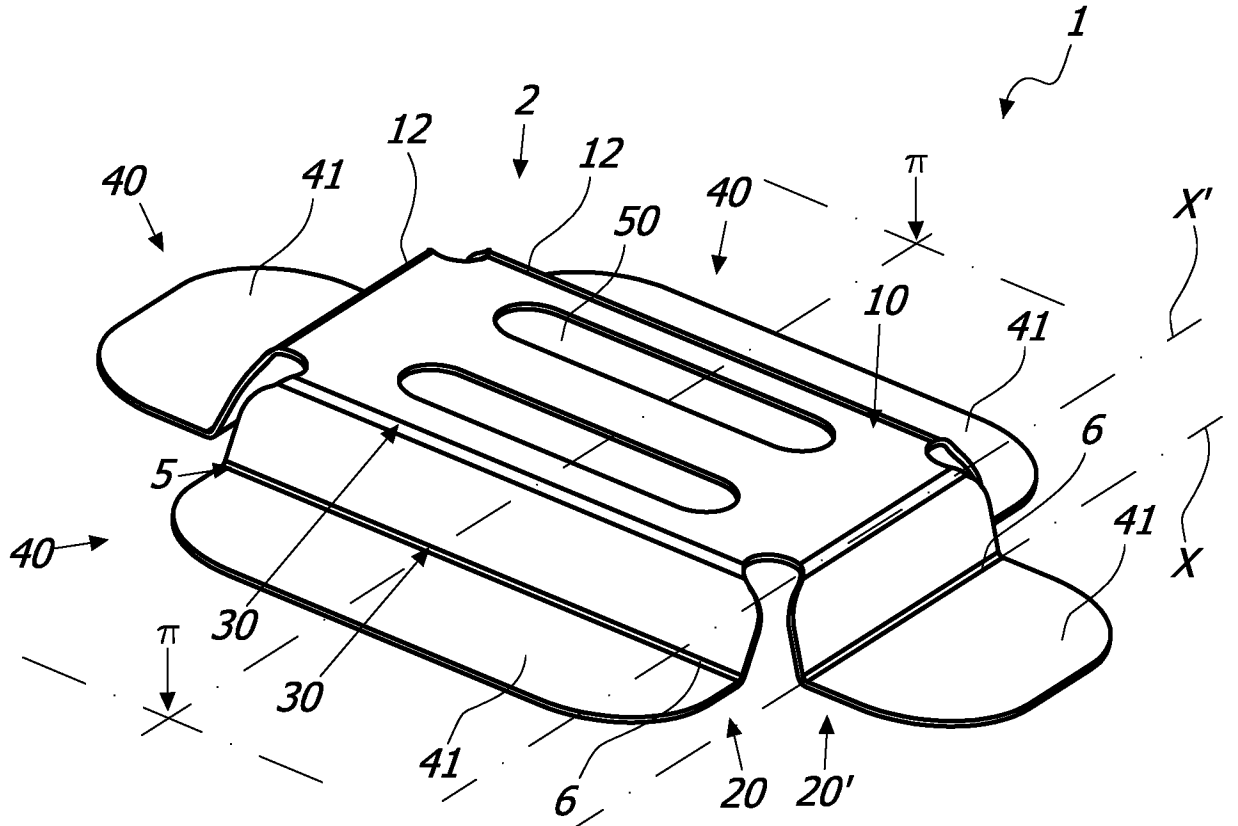

FIG. 1

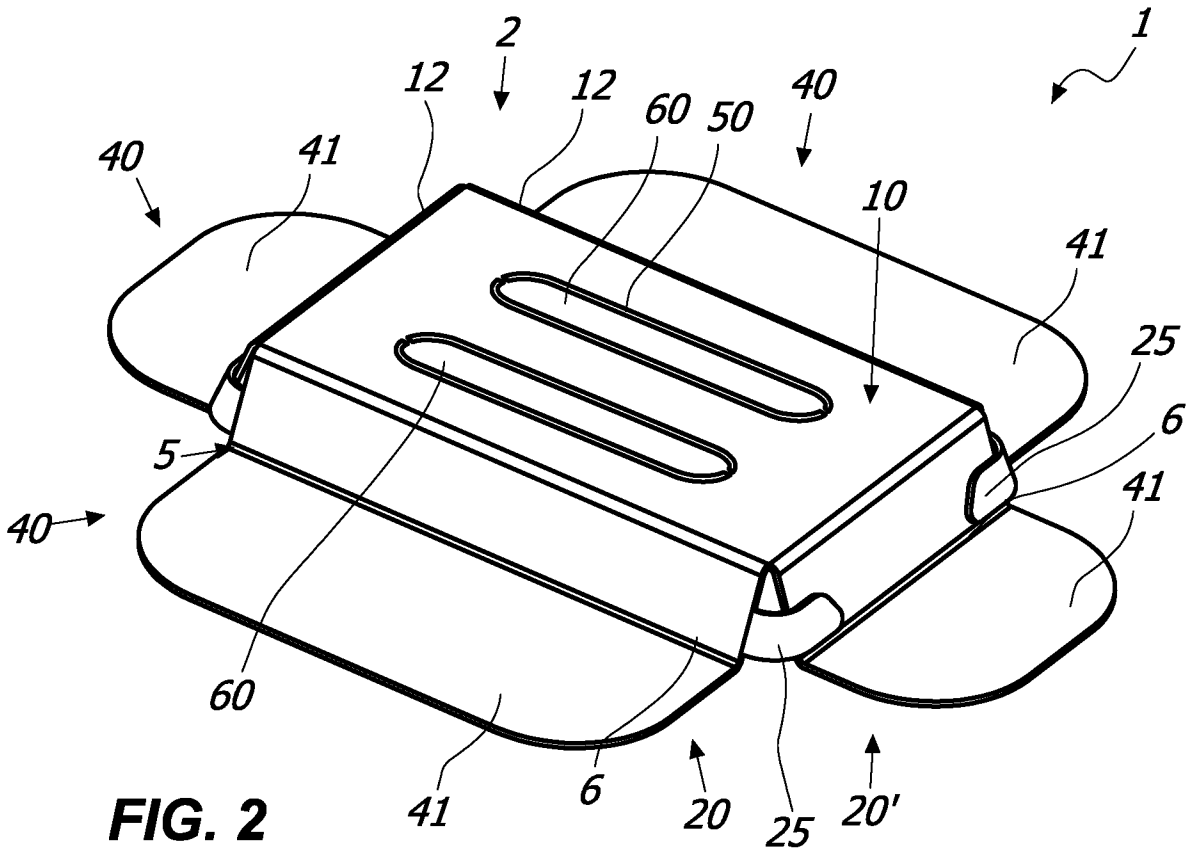
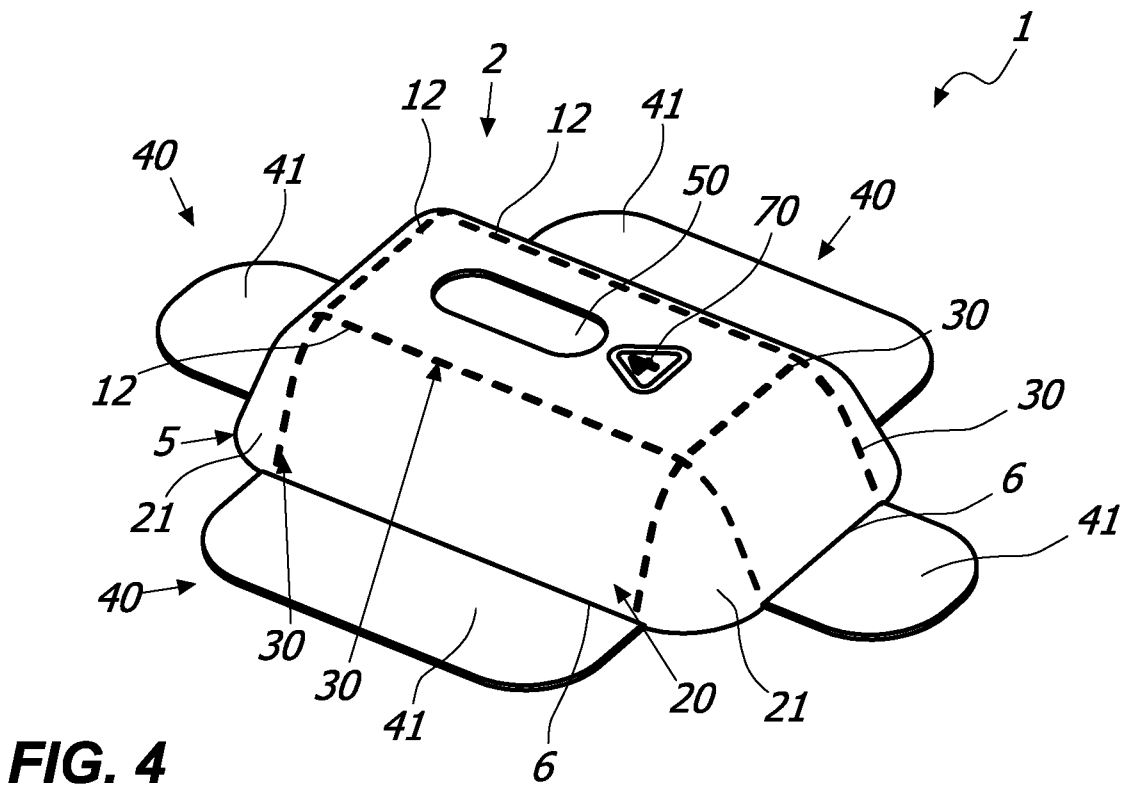
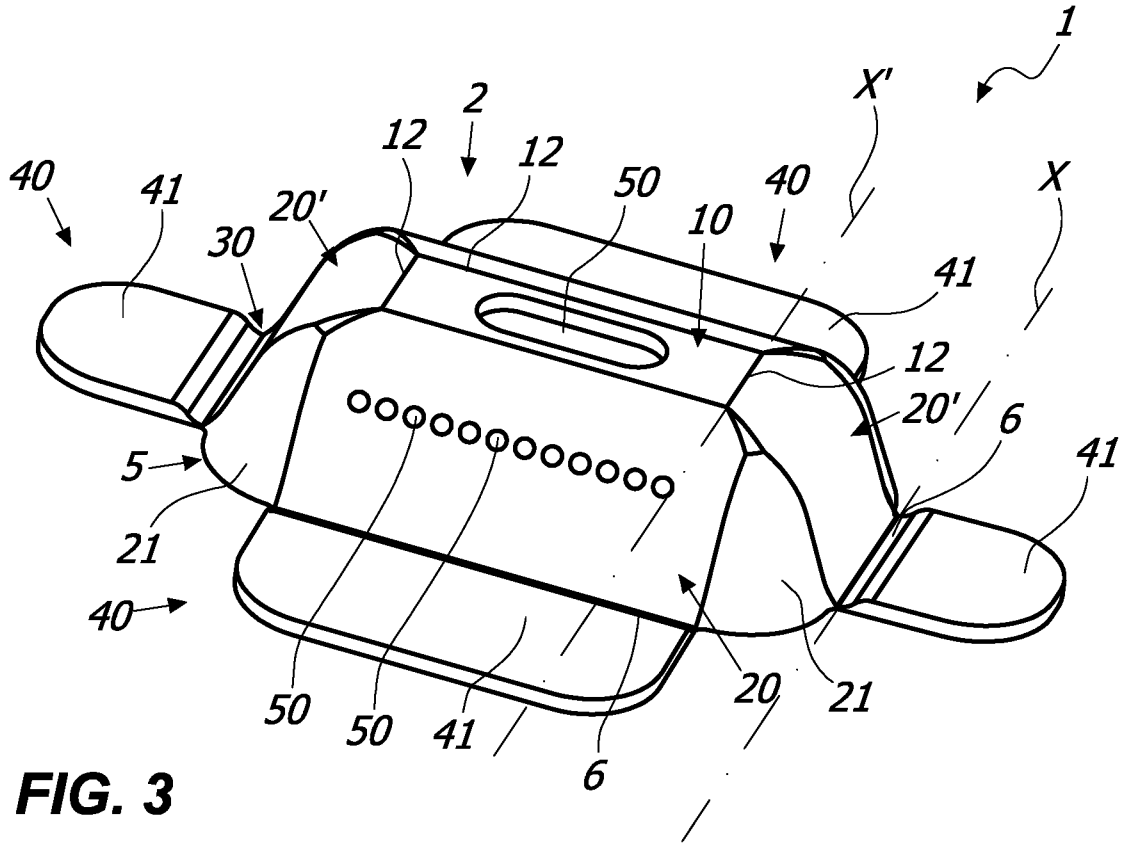

FIG. 2



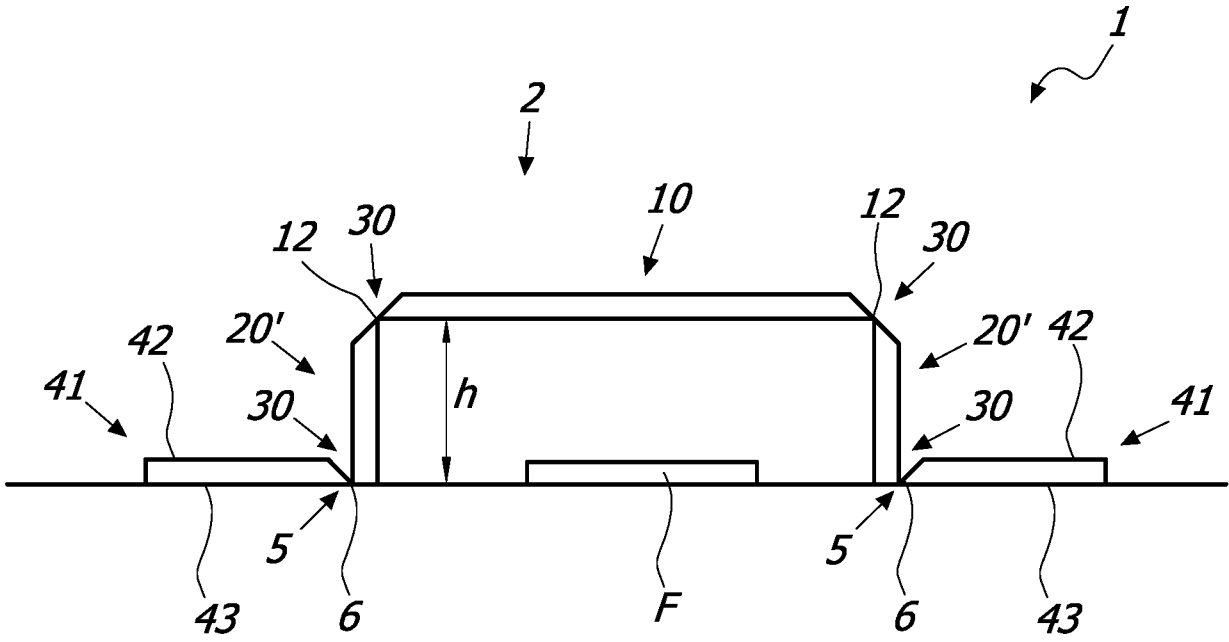

FIG. 5

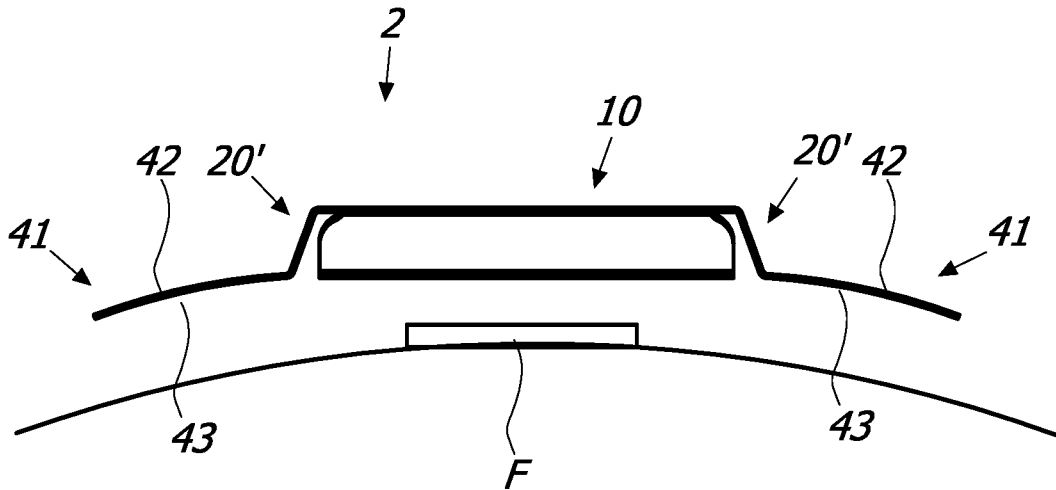

FIG. 6

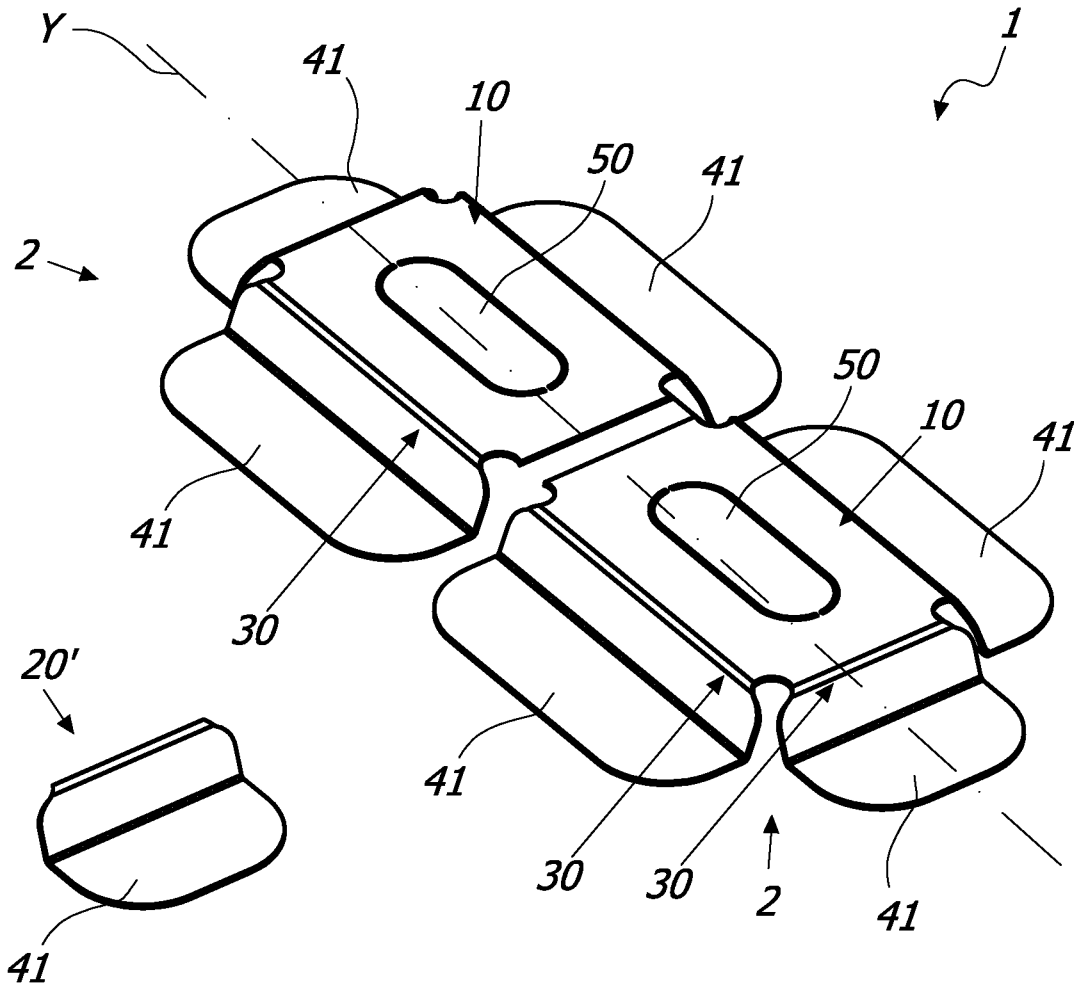

FIG. 7

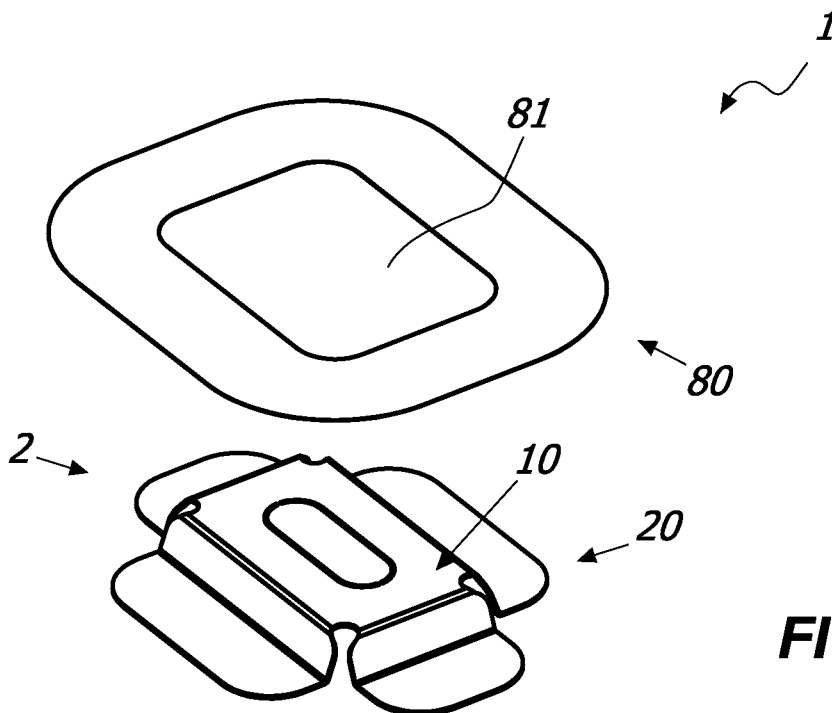

FIG. 8

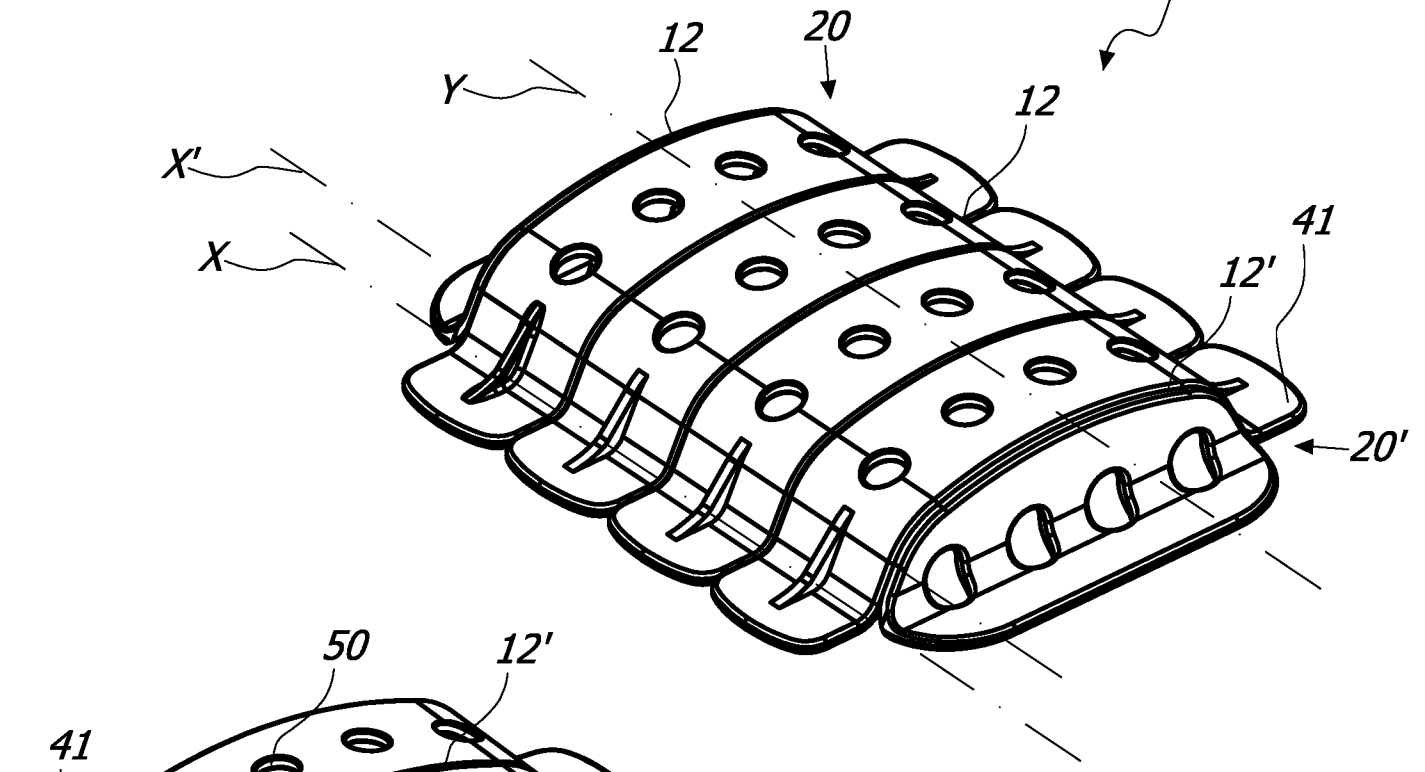

FIG. 9a

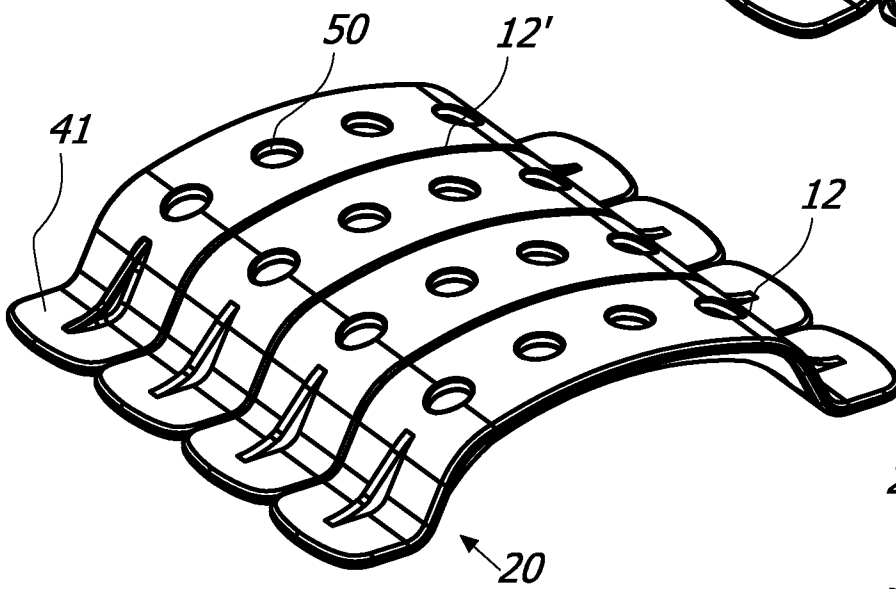

FIG. 9b

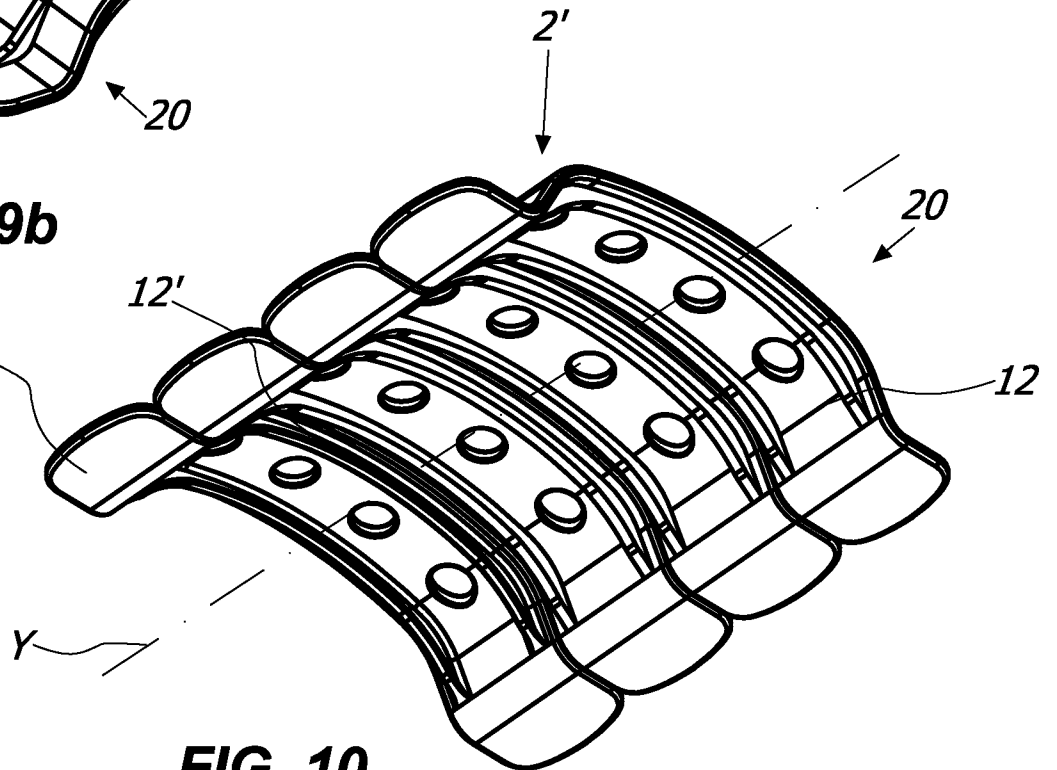

FIG. 10

INTERNATIONAL SEARCH REPORT

International application No
PCT/IB2018/060443

A. CLASSIFICATION OF SUBJECT MATTER
INV. A61F15/00 A61F13/00 A61F13/02
ADD.
According to International Patent Classification (IPC) or to both national classification and IPC

B. FIELDS SEARCHED
Minimum documentation searched (classification system followed by classification symbols)
A61F

Documentation searched other than minimum documentation to the extent that such documents are included in the fields searched

Electronic data base consulted during the international search (name of data base and, where practicable, search terms used)
EPO-Internal, WPI Data

C. DOCUMENTS CONSIDERED TO BE RELEVANT

Category*	Citation of document, with indication, where appropriate, of the relevant passages	Relevant to claim No.
Y	WO 2013/039713 A2 (3M INNOVATIVE PROPERTIES CO [US]; SCHOLZ MATTHEW T [US]; EULL PATRICIA) 21 March 2013 (2013-03-21) page 4, line 10 - page 5, line 23; figures 1-3 -----	1-12
Y	US 6 110 197 A (AUGUSTINE SCOTT D [US] ET AL) 29 August 2000 (2000-08-29) column 5, lines 8-65 column 11, line 34 - column 12, line 48; figures 1-19 -----	1-12
Y	US 2004/127838 A1 (JEZIAK MICHAEL C [US]) 1 July 2004 (2004-07-01) paragraphs [0020] - [0027]; figures -----	1-12

Further documents are listed in the continuation of Box C.

See patent family annex.

* Special categories of cited documents :

- "A" document defining the general state of the art which is not considered to be of particular relevance
- "E" earlier application or patent but published on or after the international filing date
- "L" document which may throw doubts on priority claim(s) or which is cited to establish the publication date of another citation or other special reason (as specified)
- "O" document referring to an oral disclosure, use, exhibition or other means
- "P" document published prior to the international filing date but later than the priority date claimed

- "T" later document published after the international filing date or priority date and not in conflict with the application but cited to understand the principle or theory underlying the invention
- "X" document of particular relevance; the claimed invention cannot be considered novel or cannot be considered to involve an inventive step when the document is taken alone
- "Y" document of particular relevance; the claimed invention cannot be considered to involve an inventive step when the document is combined with one or more other such documents, such combination being obvious to a person skilled in the art
- "&" document member of the same patent family

Date of the actual completion of the international search 14 March 2019	Date of mailing of the international search report 22/03/2019
--	--

Name and mailing address of the ISA/ European Patent Office, P.B. 5818 Patentlaan 2 NL - 2280 HV Rijswijk Tel. (+31-70) 340-2040, Fax: (+31-70) 340-3016	Authorized officer Boccignone, Magda
--	---

INTERNATIONAL SEARCH REPORT

Information on patent family members

International application No

PCT/IB2018/060443

Patent document cited in search report	Publication date	Patent family member(s)	Publication date
WO 2013039713	A2	21-03-2013	
		CN 103813766 A	21-05-2014
		EP 2755620 A2	23-07-2014
		JP 6258853 B2	10-01-2018
		JP 2014531238 A	27-11-2014
		US 2014221907 A1	07-08-2014
		US 2017105879 A1	20-04-2017
		WO 2013039713 A2	21-03-2013

US 6110197	A	29-08-2000	
		AT 206904 T	15-11-2001
		AU 728764 B2	18-01-2001
		CA 2284166 A1	22-10-1998
		DE 69802075 T2	06-06-2002
		EP 0973469 A1	26-01-2000
		US 6110197 A	29-08-2000
		US 6267740 B1	31-07-2001
		WO 9846178 A1	22-10-1998

US 2004127838	A1	01-07-2004	NONE
