

(19) World Intellectual Property
Organization
International Bureau



(43) International Publication Date
2 September 2004 (02.09.2004)

PCT

(10) International Publication Number
WO 2004/074455 A2

- (51) International Patent Classification⁷: C12N
- (21) International Application Number: PCT/US2004/005112
- (22) International Filing Date: 20 February 2004 (20.02.2004)
- (25) Filing Language: English
- (26) Publication Language: English
- (30) Priority Data: 10/370,749 20 February 2003 (20.02.2003) US
- (71) Applicant (for all designated States except US): **APPLIED MOLECULAR EVOLUTION** [US/US]; 3520 Dunhill Street, San Diego, CA 92121 (US).
- (72) Inventors; and
- (75) Inventors/Applicants (for US only): **WATKINS, Jeffrey, D.** [US/US]; 3442 Fortuna Ranch Road, Olivenhain CA 92024 (US). **ALLAN, Barrett** [US/US]; 542 San Diego Drive, Encinitas, CA 92024 (US).
- (74) Agents: **BOND, Jason, R.** et al.; Medlen & Carroll, LLP, 101 Howard Street, Suite 350, San Francisco, CA 94105 (US).
- (81) Designated States (unless otherwise indicated, for every kind of national protection available): AE, AG, AL, AM, AT, AU, AZ, BA, BB, BG, BR, BW, BY, BZ, CA, CH, CN, CO, CR, CU, CZ, DE, DK, DM, DZ, EC, EE, EG, ES, FI, GB, GD, GE, GH, GM, HR, HU, ID, IL, IN, IS, JP, KE, KG, KP, KR, KZ, LC, LK, LR, LS, LT, LU, LV, MA, MD, MG, MK, MN, MW, MX, MZ, NA, NI, NO, NZ, OM, PG, PH, PL, PT, RO, RU, SC, SD, SE, SG, SK, SL, SY, TJ, TM, TN, TR, TT, TZ, UA, UG, US, UZ, VC, VN, YU, ZA, ZM, ZW.
- (84) Designated States (unless otherwise indicated, for every kind of regional protection available): ARIPO (BW, GH, GM, KE, LS, MW, MZ, SD, SL, SZ, TZ, UG, ZM, ZW), Eurasian (AM, AZ, BY, KG, KZ, MD, RU, TJ, TM), European (AT, BE, BG, CH, CY, CZ, DE, DK, EE, ES, FI, FR, GB, GR, HU, IE, IT, LU, MC, NL, PT, RO, SE, SI, SK, TR), OAPI (BF, BJ, CF, CG, CI, CM, GA, GN, GQ, GW, ML, MR, NE, SN, TD, TG).
- Published:**
— without international search report and to be republished upon receipt of that report
- For two-letter codes and other abbreviations, refer to the "Guidance Notes on Codes and Abbreviations" appearing at the beginning of each regular issue of the PCT Gazette.*



WO 2004/074455 A2

(54) Title: Fc REGION VARIANTS

(57) Abstract: The present invention provides polypeptide Fc region variants and oligonucleotides encoding Fc region variants. Specifically, the present invention provides compositions comprising novel Fc region variants, methods for identifying useful Fc region variants, and methods for employing Fc region variants for treating disease.

Fc REGION VARIANTS

The present Application claims priority to U.S. Application Serial Number 10/370,749, filed February 20, 2003.

5

FIELD OF THE INVENTION

The present invention relates to polypeptide Fc region variants and oligonucleotides encoding Fc region variants. Specifically, the present invention provides compositions comprising novel Fc region variants, methods for identifying useful Fc region variants, and
10 methods for employing Fc region variants (e.g. for treating disease).

BACKGROUND OF THE INVENTION

There are five types of immunoglobulins in humans. These groups are known as IgG, IgM, IgD, IgA, and IgE, and are distinguished based on the isotypes of the heavy chain
15 gene (gamma, mu, delta, alpha, and epsilon respectively). The most common isotype is IgG, and is composed of two identical heavy chain polypeptides and two identical light chain polypeptides (See, Figure 1). The two heavy chains are covalently linked to each other by a disulfide bonds and each light chain is linked to a heavy chain by a disulfide bond (See, Figure 1). Each heavy chain contains approximately 445 amino acid residues,
20 and each light chain contains approximately 215 amino acid residues.

Each heavy chain contains four distinct domains that are generally referred to as variable domain (VH), constant heavy domain 1 (CH1), constant heavy domain 2 (CH2), and constant heavy domain 3 (CH3) (See, Figure 1). The CH1 and CH2 domains are joined by a hinge region (inter-domain sections) that provides the Ig with flexibility. Each light
25 chain contains two distinct domains that are generally referred to as the variable light (VL) and the constant light (CL).

The variable regions of the heavy and light chains directly bind antigen and are responsible for the diversity and specificity of Igs. Each VL and VH has three complementarity-determining regions (CDRs, also known as hyper variable regions). When
30 the VL and VH come together through interactions of the heavy and light chain, the CDRs form a binding surface that contacts the antigen.

While the variable regions are involved in antigen binding, the heavy chain constant domains, primarily CH2 and CH3, are involved in non-antigen binding functions. This region, generally known as the Fc region, has many important functions. For example, the

Fc region binds complement, which may trigger phagocytosis or complement dependent cytotoxicity (CDC). The Fc region also binds Fc receptors, which may trigger phagocytosis or antibody dependent cellular cytotoxicity (ADCC). The Fc region also plays a role in helping to maintain the immunoglobulin in circulation.

5 There has recently been an effort to improve the immunogenic qualities and antigen binding characteristics of antibodies. For example, monoclonal, chimeric and humanized antibodies have been developed for immunotherapy. Examples of antibodies that have been approved for human immunotherapy, with the corresponding disease, include: RITUXAN (lymphoma), SYNAGIS (infectious disease), ZENEPAX (kidney transplant), REMICADE
10 (Crohn's disease and rheumatoid arthritis), HERCEPTIN (breast carcinoma), and EDRECOLOMAB (colon cancer). However, there are many antibodies that have entered clinical trials that have failed to receive approval due to lack of efficacy or other associated problems.

 What is needed, in order to improve the efficacy and speed up approval of additional
15 therapeutic antibodies, are compositions and methods for altering Fc regions to generate variant polypeptides with improved properties.

SUMMARY OF THE INVENTION

 The present invention provides polypeptide Fc region variants and oligonucleotides
20 encoding Fc region variants, and portions thereof. Specifically, the present invention provides compositions comprising novel Fc region variants, methods for identifying useful Fc region variants, and methods for employing Fc region variants.

 In some embodiments, the present invention provides compositions comprising a variant (or a nucleic acid sequence encoding the variant) of a parent polypeptide having at
25 least a portion of an Fc region, wherein the variant mediates antibody-dependent cell-mediated cytotoxicity (ADCC) in the presence of effector cells more effectively than the parent polypeptide and comprises at least one amino acid modification at position 280 in the Fc region. In certain embodiments, the variant interacts with Fc gamma receptor III (FcγRIII) with a higher assay signal than the parent polypeptide. In other embodiments, the
30 variant interacts with Fc gamma receptor IIb (FcγRIIb) with a lower assay signal than the parent polypeptide. In particular embodiments, the variant comprises an antibody (e.g. a CD20 antibody). In preferred embodiments, the amino acid modification is D280H.

 In other embodiments, the present invention provides compositions comprising a variant (or a nucleic acid sequence encoding the variant) of a parent polypeptide having at

least a portion of an Fc region, wherein the variant mediates antibody-dependent cell-mediated cytotoxicity (ADCC) in the presence of effector cells more effectively than the parent polypeptide and comprises at least one amino acid modification at position 290 in the Fc region. In certain embodiments, the variant interacts with Fc gamma receptor III (FcγRIII) with a higher assay signal than the parent polypeptide. In particular
5 (FcγRIII) with a higher assay signal than the parent polypeptide. In particular embodiments, the variant interacts with Fc gamma receptor IIb (FcγRIIb) with a higher assay signal than the parent polypeptide. In particular embodiments, the variant comprises an antibody (e.g. a CD20 antibody). In preferred embodiments, the amino acid modification is K290S.

10 In some embodiments, the present invention provides a peptide (containing the D280H amino acid modification) with the following sequence: VKFNWYVHGVEVHNA (SEQ ID NO:49). In other embodiments, the present invention provides a nucleic acid sequence encoding a CH2 region with the D280H modification (e.g. SEQ ID NO:52). In some embodiments, the present invention provides an amino acid sequence encoding a CH2
15 region with the D280H modification comprising SEQ ID NO:51. In certain embodiments, the present invention provides a peptide (containing the K290S modification) with the following sequence: EVHNAKTSPREEQYN (SEQ ID NO:50). In additional embodiments, the present invention provides a nucleic acid sequence encoding a CH2 region with the K290S modification (e.g. SEQ ID NO:54). In additional embodiments, the
20 present invention provides an amino acid sequence encoding a CH2 region with the K290S modification comprising SEQ ID NO:53.

In some embodiments, the present invention provides compositions comprising a variant of a parent polypeptide having at least a portion of an Fc region, wherein the variant has an altered effector function compared to the parent polypeptide and comprises at least
25 one amino acid modification at position 280 in the Fc region. In certain embodiments, the variant mediates antibody-dependent cell-mediated cytotoxicity (ADCC) in the presence of effector cells more effectively than the parent polypeptide. In other embodiments, the amino acid modification is D280K, D280A, D280H, D280N, or D280T.

In particular embodiments, the present invention provides compositions comprising
30 a variant of a parent polypeptide having at least a portion of an Fc region, wherein the variant has an altered effector function compared to the parent polypeptide and comprises at least one amino acid modification at position 290 in the Fc region. In some embodiments, the variant has higher complement dependent cytotoxicity activity than the parent

polypeptide. In certain embodiments, the amino acid modification is K290D, K290P, K290N, K290T, K290S, or K290V.

In further embodiments, the present invention provides compositions comprising a peptide, wherein the peptide comprises an amino acid sequence selected from the group consisting of SEQ ID NOs: 49, 50, 51, 53, and 55-63. In other embodiments, the peptide is attached to a therapeutic or diagnostic moiety (e.g. drug, hormone, antibody, label, etc.).

In some embodiments, the present invention provides compositions comprising a variant (or a nucleic acid sequence encoding the variant) of a parent polypeptide having at least a portion of an Fc region, wherein the variant comprises at least one amino acid modification at position 280 in the Fc region selected from D280H, D280Q, and D280Y. In other embodiments, the present invention provides compositions comprising a variant (or a nucleic acid sequence encoding the variant) of a parent polypeptide having at least a portion of an Fc region, wherein the variant comprises at least one amino acid modification at position 290 in the Fc region selected from K290S, K290G, K290T, and K290Y.

In some embodiments, the present invention provides compositions comprising a variant of a parent polypeptide having at least a portion of an Fc region, wherein the variant binds an Fc gamma receptor (FcγR) with higher affinity, or the variant interacts with an FcγR with a higher assay signal, than the parent polypeptide and comprises at least one amino acid modification at position 300 in the Fc region. In other embodiments, the present invention provides methods comprising; a) providing; i) a composition comprising a variant of a parent polypeptide having at least a portion of an Fc region, wherein the variant binds an Fc gamma receptor (FcγR) with higher affinity, or the variant interacts with an FcγR with a higher assay signal, than the parent polypeptide and comprises at least one amino acid modification at position 300 in the Fc region, and ii) a subject with one or more symptoms of a disease; and b) administering the composition to the subject under conditions such that at least one of the symptoms is reduced. In particular embodiments the variant comprises an antibody or immunoadhesin, and the subject has symptoms of an antibody or immunoadhesin responsive disease.

In some embodiments, the compositions comprise a variant of a parent polypeptide having at least a portion of an Fc region, wherein the variant mediates antibody-dependent cell-mediated cytotoxicity (ADCC) in the presence of effector cells less effectively than the parent polypeptide and comprises at least one amino acid modification at position 300 in the Fc region.

In other embodiments, the compositions comprise a polypeptide comprising a variant Fc region which displays increased binding to an Fc γ R, wherein the polypeptide comprises an amino acid modification at amino acid position 300. In certain embodiments, the compositions comprise a nucleic acid sequence encoding a variant of a parent
5 polypeptide comprising an Fc region, wherein the variant binds an Fc gamma receptor (Fc γ R) with a higher assay signal, or a higher affinity, than the parent polypeptide, and/or mediates antibody-dependent cell-mediated cytotoxicity (ADCC) in the presence of effector cells less effectively than the parent polypeptide, and comprises at least one amino acid modification at position 300 in the Fc region. In yet other embodiments, the compositions
10 comprise a nucleic acid sequence encoding a variant Fc polypeptide which displays increased binding to an Fc γ R, and/or mediates antibody-dependent cell-mediated cytotoxicity (ADCC) in the presence of effector cells less effectively than the parent polypeptide, wherein the variant Fc polypeptide comprises an amino acid modification at amino acid position 300.

15 In certain embodiments, the variant comprises at least a portion of the Fc region (e.g. 40%, 50%, 60%, 80%, or 90% or more of an Fc region containing the amino acid modification). In some embodiments, the polypeptide variants comprises a CH2 or CH3 region. In further embodiments, the compositions comprise an amino acid sequence comprising SEQ ID NO:26. In some embodiments, the compositions comprise an amino
20 acid sequence comprising SEQ ID NO:27. In certain embodiments, the compositions comprise a nucleic acid sequence comprising SEQ ID NO:38 and/or SEQ ID NO:39, or the complement thereof, or sequences that bind to SEQ ID NO:38 and 39 under conditions of high stringency. In further embodiments, the present invention provides host cells (e.g. CHO cells), and vectors comprising SEQ ID NO:38 and/or SEQ ID NO:39. In particular
25 embodiments, the present invention provides a computer readable medium, wherein the computer readable medium encodes a representation of SEQ ID NO:26, 27, 38 or 39.

In certain embodiments, the polypeptide variant binds an Fc γ R with at least 25% greater affinity, or generates an assay signal at least 25% higher, than the parent polypeptide. In other embodiments, the Fc γ R is Fc γ RIII or Fc γ RIIb. In some
30 embodiments, the polypeptide variant comprises an antibody or antibody fragment (e.g., polyclonal antibody, monoclonal antibody, chimeric antibody, humanized antibody, or Fc fragment). In some embodiments, the parent polypeptide comprises a human IgG Fc region. In additional embodiments, the parent polypeptide comprises a human IgG1, IgG2, IgG3, or IgG4 Fc region. In other embodiments, the parent polypeptide comprises an amino

acid sequence selected from SEQ ID NO:15, SEQ ID NO:16, SEQ ID NO:17, SEQ ID NO:18, SEQ ID NO:19, SEQ ID NO:20, SEQ ID NO:21, SEQ ID NO:22, SEQ ID NO:23, SEQ ID NO:24, SEQ ID NO:25 and SEQ ID NO:48.

In preferred embodiments, the amino acid modification is Y300I or Y300L. In certain embodiments, the polypeptide variant comprises a second amino acid modification in the Fc region (see, e.g. Tables 1 and 2). In some embodiments, the variant is a CHO-expressed polypeptide.

In certain embodiments, the present invention provides compositions comprising a variant of a parent polypeptide having at least a portion of an Fc region, wherein the variant binds an Fc gamma receptor III (FcγRIII) with higher affinity, or the variant interacts with an FcγRIII with a higher assay signal, than the parent polypeptide and comprises at least one amino acid modification at position 295 in the Fc region. In other embodiments, the present invention provides methods comprising; a) providing; i) a composition comprising a variant of a parent polypeptide having at least a portion of an Fc region, wherein the variant binds an Fc gamma receptor III (FcγRIII) with higher affinity, or the variant interacts with an FcγRIII with a higher assay signal, than the parent polypeptide and comprises at least one amino acid modification at position 295 in the Fc region, and ii) a subject with one or more symptoms of a disease; and b) administering the composition to the subject under conditions such that at least one of the symptoms are reduced. In preferred embodiments, the variant comprises an antibody or immunoadhesin, and the subject has symptoms of an antibody or immunoadhesin responsive disease.

In some embodiments, the compositions comprise a variant of a parent polypeptide having at least a portion of an Fc region, wherein the variant mediates antibody-dependent cell-mediated cytotoxicity (ADCC) in the presence of effector cells less effectively than the parent polypeptide and comprises at least one amino acid modification at position 295 in the Fc region.

In certain embodiments, the compositions comprise a polypeptide comprising at least a portion of a variant Fc region which displays increased binding to an FcγRIII, wherein the polypeptide comprises an amino acid modification at amino acid position 295. In other embodiments, the compositions comprise a nucleic acid sequence encoding a variant of a parent polypeptide comprising at least a portion of an Fc region, wherein the variant binds an Fc gamma receptor III (FcγRIII) with higher affinity, or the variant interacts with an FcγRIII with a higher assay signal, than the parent polypeptide, and/or mediates antibody-dependent cell-mediated cytotoxicity (ADCC) in the presence of effector

cells less effectively than the parent polypeptide, and comprises at least one amino acid modification at position 295 in the Fc region. In some embodiments, the compositions comprise a nucleic acid sequence encoding at least a portion of a variant Fc polypeptide which displays increased binding (or increases assay signal compared to a parent

5 polypeptide) to an FcγRIII, and/or mediates antibody-dependent cell-mediated cytotoxicity (ADCC) in the presence of effector cells less effectively than the parent polypeptide, wherein the variant Fc polypeptide comprises an amino acid modification at amino acid position 295.

In certain embodiments, the polypeptide variant comprises at least a portion of the

10 Fc region (e.g. 40%, 50%, 60%, 80%, or 90% or more of an Fc region containing the amino acid modification). In some embodiments, the polypeptide variants comprise a CH2 or CH3 region. In further embodiments, the compositions comprise an amino acid sequence comprising SEQ ID NO:28 or SEQ ID NO:33. In certain embodiments, the compositions comprise a nucleic acid sequence comprising SEQ ID NO:40 and/or SEQ ID NO:45, or the

15 complement thereof, or sequences that bind to SEQ ID NO:40 and 45 under conditions of high stringency. In further embodiments, the present invention provides host cells (e.g. CHO cells), and vectors comprising SEQ ID NO:40 and/or SEQ ID NO:45. In particular embodiments, the present invention provides a computer readable medium, wherein the computer readable medium encodes a representation of SEQ ID NO:28, 33, 40 or 45.

In certain embodiments, the polypeptide variant binds an FcγRIIb with lower

20 affinity, or the variant interacts with FcγRIIb with a lower assay signal, than the parent polypeptide. In other embodiments, the variant binds an FcγRIIb with higher affinity, or the variant interacts with an FcγRIIb with a higher assay signal, than the parent polypeptide. In some embodiments, the variant binds an FcγRIIa with higher affinity, or the variant

25 interacts with an FcγRIIa with a higher assay signal, than the parent polypeptide. In preferred embodiments, the variant comprises an antibody. In other preferred embodiments, the parent polypeptide comprises a human IgG Fc region. In particular embodiments, the parent polypeptide comprises a human IgG1, IgG2, IgG3, or IgG4 Fc region. In other

30 embodiments, the parent polypeptide comprises an amino acid sequence selected from SEQ ID NO:15, SEQ ID NO:16, SEQ ID NO:17, SEQ ID NO:18, SEQ ID NO:19, SEQ ID NO:20, SEQ ID NO:21, SEQ ID NO:22, SEQ ID NO:23, SEQ ID NO:24, SEQ ID NO:25 and SEQ ID NO:48.

In some embodiments, the amino acid modification in the polypeptide variant is Q295K. In certain embodiments, the amino acid modification in the polypeptide variant is

Q295L. In other embodiments, the variant comprises a second amino acid modification in the Fc region (See, e.g., Tables 1 and 2 below). In particular embodiments, the variant is a CHO-expressed polypeptide.

In some embodiments, the present invention provides compositions comprising a variant of a parent polypeptide having at least a portion of an Fc region, wherein the variant binds an Fc gamma receptor III (FcγRIII) with higher affinity, or the variant interacts with an FcγRIII with a higher assay signal, than the parent polypeptide and comprises at least one amino acid modification at position 294 in the Fc region. In other embodiments, the present invention provides methods comprising; a) providing; i) a composition comprising a variant of a parent polypeptide having at least a portion of an Fc region, wherein the variant binds an Fc gamma receptor III (FcγRIII) with higher affinity, or the variant interacts with an FcγR with a higher assay signal, than the parent polypeptide and comprises at least one amino acid modification at position 294 in the Fc region, and ii) a subject with one or more symptoms of a disease; and b) administering the composition to the subject under conditions such that at least one of the symptoms is reduced. In additional embodiments, the variant comprises an antibody or immunoadhesin, and the subject has symptoms of an antibody or immunoadhesin responsive disease.

In some embodiments, the compositions comprise a variant of a parent polypeptide having at least a portion of an Fc region, wherein the variant mediates antibody-dependent cell-mediated cytotoxicity (ADCC) in the presence of effector cells less effectively than the parent polypeptide and comprises at least at least one amino acid modification at position 294 in the Fc region. In other embodiments, the compositions comprise a polypeptide comprising a variant Fc region which displays increased binding to an FcγRIII, wherein the polypeptide comprises an amino acid modification at amino acid position 294.

In further embodiments, the compositions comprise a nucleic acid sequence encoding a variant of a parent polypeptide comprising at least a portion of an Fc region, wherein the variant binds an Fc gamma receptor III (FcγRIII) with better affinity, or the variant interacts with an FcγRIII with a higher assay signal, than the parent polypeptide, and/or mediates antibody-dependent cell-mediated cytotoxicity (ADCC) in the presence of effector cells less effectively than the parent polypeptide, and comprises at least one amino acid modification at position 294 in the Fc region. In some embodiments, the compositions comprise a nucleic acid sequence encoding a variant Fc polypeptide which displays increased binding to an FcγRIII, and/or mediates antibody-dependent cell-mediated cytotoxicity (ADCC) in the presence of effector cells less effectively than the parent

polypeptide, wherein the variant Fc polypeptide comprises an amino acid modification at amino acid position 294.

In certain embodiments, the variant comprises at least a portion of the Fc region (e.g. 40%, 50%, 60%, 80%, or 90% or more of an Fc region containing the amino acid
5 modification. In some embodiments, the polypeptide variants comprise a CH2 or CH3 region. In further embodiments, the compositions comprise an amino acid sequence comprising SEQ ID NO:29. In some embodiments, the present invention provides compositions comprising a nucleic acid sequence comprising SEQ ID NO:41, or the
10 complement thereof, or sequences that bind to SEQ ID NO:41 under conditions of high stringency. In other embodiments, the present invention provides host cells (e.g., CHO cells) and vectors comprising SEQ ID NO:41. In other embodiments, the present invention provides a computer readable medium, wherein the computer readable medium encodes a representation of SEQ ID NO:29 or 41.

In certain embodiments, the variant binds an FcγRIIb with lower affinity, or the
15 variant interacts with an FcγRIIb with a lower assay signal, than the parent polypeptide. In some embodiments, the polypeptide variant comprises an antibody or immunoadhesin. In some embodiments, the parent polypeptide comprises a human IgG Fc region. In particular embodiments, the parent polypeptide comprises a human IgG1, IgG2, IgG3, or IgG4 Fc region. In certain embodiments, the parent polypeptide comprises an amino acid sequence
20 selected from SEQ ID NO:15, SEQ ID NO:16, SEQ ID NO:17, SEQ ID NO:18, SEQ ID NO:19, SEQ ID NO:20, SEQ ID NO:21, SEQ ID NO:22, SEQ ID NO:23, SEQ ID NO:24, SEQ ID NO:25 and SEQ ID NO:48.

In certain preferred embodiments, the amino acid modification in the polypeptide variant is E294N. In some embodiments, the polypeptide variant comprises a second amino
25 acid modification in the Fc region (See, e.g., Tables 1 and 2). In other embodiments, the variant is a CHO-expressed polypeptide.

In some embodiments, the present invention provides compositions comprising a variant of a parent polypeptide having at least a portion of an Fc region, wherein the variant has a relative binding affinity, or relative assay signal, for FcγRIII or FcγRIIb that is
30 approximately 0.25 or less as measured in an ELISA FcγR binding assay. In other embodiments, the present invention provides methods comprising: a) providing; i) a composition comprising a variant of a parent polypeptide having at least a portion of an Fc region, wherein the variant has a relative binding affinity, or a relative assay signal, for FcγRIII or FcγRIIb that is approximately 0.25 or less as measured in an ELISA FcγR

binding assay, and ii) a subject with one or more symptoms of a disease; and b) administering the composition to the subject under conditions such that at least one of the symptoms are reduced. In other embodiments, the polypeptide variant comprises an antibody or immunoadhesin, and the subject has symptoms of an antibody or immunoadhesin responsive disease.

In certain embodiments, the variant has a relative binding affinity, or relative assay signal, for Fc γ RIII or Fc γ RIIb that is approximately 0.10 or less as measured in an ELISA Fc γ R binding assay. In some embodiments, the variant has a relative binding affinity, or relative assay signal, for Fc γ RIII or Fc γ RIIb that is approximately 0.0 as measured in an ELISA Fc γ R binding assay. In preferred embodiments, the variant comprises at least one amino acid modification at position 296 in the Fc region. In preferred embodiments, the amino acid modification at position 296 is Y296P. In some embodiments, the variant comprises at least one amino acid modification at position 298 in the Fc region. In other embodiments, the at least one amino acid modification at position 298 is S298P.

In further embodiments, the compositions comprise a polypeptide comprising a variant Fc region, wherein the polypeptide has a relative binding affinity, or relative assay signal, for Fc γ RIII or Fc γ RIIb that is approximately 0.25 or less (e.g. 0.15, 0.10, or 0.0) as measured in an ELISA Fc γ R binding assay. In certain embodiments, the variant comprises an amino acid modification at position 296 (e.g., Y296P). In other embodiments, the compositions comprise a nucleic acid sequence encoding a variant of a parent polypeptide comprising an Fc region, wherein the variant has a relative binding affinity, or relative assay signal, for Fc γ RIII or Fc γ RIIb that is approximately 0.25 or less (e.g. 0.15, 0.10, or 0.0) as measured in an ELISA Fc γ R binding assay. In further embodiments, the compositions comprise a nucleic acid sequence encoding a variant Fc polypeptide which has a relative binding affinity, or relative assay signal, for Fc γ RIII or Fc γ RIIb that is approximately 0.25 or less as measured in an ELISA Fc γ R binding assay.

In certain embodiments, the variant comprises at least a portion of the Fc region (e.g. 40%, 50%, 60%, 80%, or 90% or more of an Fc region containing the amino acid modification. In some embodiments, the variants comprises a CH2 or CH3 region. In some embodiments, the compositions comprise an amino acid sequence comprising SEQ ID NO:35. In other embodiments, the compositions comprise a nucleic acid sequence comprising SEQ ID NO:47, or the complement thereof, or sequences that bind to SEQ ID NO:47 under conditions of high stringency. In further embodiments, the present invention provides host cells (e.g. CHO cells) and vectors comprising SEQ ID NO:47. In other

embodiments, the present invention provides a computer readable medium, wherein the computer readable medium encodes a representation of SEQ ID NO:35 or 47.

In certain preferred embodiments, the polypeptide variant comprises an antibody. In other embodiments, the parent polypeptide comprises a human IgG Fc region. In some
5 embodiments, the parent polypeptide comprises a human IgG1, IgG2, IgG3, or IgG4 Fc region. In particular embodiments, the parent polypeptide comprises an amino acid sequence selected from SEQ ID NO:15, SEQ ID NO:16, SEQ ID NO:17, SEQ ID NO:18, SEQ ID NO:19, SEQ ID NO:20, SEQ ID NO:21, SEQ ID NO:22, SEQ ID NO:23, SEQ ID NO:24, SEQ ID NO:25 and SEQ ID NO:48.

10 In certain embodiments, the polypeptide variant comprises a second amino acid modification in the Fc region (See, e.g., Tables 1 and 2 below). In some embodiments, the variant is a CHO-expressed polypeptide.

In some embodiments, the present invention provides compositions comprising a variant of a parent polypeptide having at least a portion of an Fc region, wherein the variant
15 binds an FcγRIII with higher affinity, and FcγRIIb with lower affinity, than the parent polypeptide and comprises a S298N amino acid modification in the Fc region. In certain embodiments, the present invention provides compositions comprising a variant of a parent polypeptide having at least a portion of an Fc region, wherein the variant interacts with an FcγRIII with higher assay signal, and FcγRIIb with lower assay signal, than the parent
20 polypeptide and comprises a S298N amino acid modification in the Fc region. In other embodiments, the present invention provides methods comprising; a) providing; i) a composition comprising a variant of a parent polypeptide having at least a portion of an Fc region, wherein the variant binds an FcγRIII with higher affinity, and FcγRIIb with lower affinity, than the parent polypeptide and comprises a S298N amino acid modification in the
25 Fc region, and ii) a subject with one or more symptoms of a disease, and b) administering the composition to the subject under conditions such that at least one of the symptoms is reduced. In some embodiments, the present invention provides methods comprising; a) providing; i) a composition comprising a variant of a parent polypeptide having at least a portion of an Fc region, wherein the variant interacts with an FcγRIII with a higher assay
30 signal, and FcγRIIb with a lower assay signal, than the parent polypeptide and comprises a S298N amino acid modification in the Fc region, and ii) a subject with one or more symptoms of a disease, and b) administering the composition to the subject under conditions such that at least one of the symptoms is reduced. In certain embodiments, the polypeptide

variant comprises an antibody or immunoadhesin, and the subject has symptoms of an antibody or immunoadhesin responsive disease.

In some embodiments, the compositions comprise a variant of a parent polypeptide having at least a portion of an Fc region, wherein the variant mediates antibody-dependent cell-mediated cytotoxicity (ADCC) in the presence of effector cells less effectively than the parent polypeptide and comprises a S298N amino acid modification in the Fc region.

In particular embodiments, the compositions comprise a polypeptide comprising a variant Fc region wherein the polypeptide binds an Fc γ RIII with higher affinity, and Fc γ RIIb with lower affinity, than the parent polypeptide and comprises a S298N amino acid modification in the Fc region. In certain embodiments, the compositions comprise a polypeptide comprising a variant Fc region wherein the polypeptide interacts with an Fc γ RIII with a higher assay signal, and Fc γ RIIb with a lower assay signal, than the parent polypeptide and comprises a S298N amino acid modification in the Fc region. In further embodiments, the composition comprises a nucleic acid sequence encoding a variant of a parent polypeptide comprising at least a portion of an Fc region, wherein the variant binds an Fc γ RIII with higher affinity, and Fc γ RIIb with lower affinity, than the parent polypeptide, and/or the variant interacts with an Fc γ RIII with a higher assay signal, and Fc γ RIIb with a lower assay signal, than the parent polypeptide and comprises a S298N amino acid modification in the Fc region, and/or mediates antibody-dependent cell-mediated cytotoxicity (ADCC) in the presence of effector cells less effectively than the parent polypeptide, and comprises a S298N amino acid modification in the Fc region. In yet other embodiments, the composition comprises a nucleic acid sequence encoding a variant Fc polypeptide which binds an Fc γ RIII with higher affinity, and Fc γ RIIb with lower affinity, than the parent polypeptide, and/or the variant interacts with an Fc γ RIII with a higher assay signal, and Fc γ RIIb with a lower assay signal, than the parent polypeptide and comprises a S298N amino acid modification in the Fc region, and/or mediates antibody-dependent cell-mediated cytotoxicity (ADCC) in the presence of effector cells less effectively than the parent polypeptide, and comprises a S298N amino acid modification in the Fc region.

In certain embodiments, the variant comprises at least a portion of the Fc region (e.g. 40%, 50%, 60%, 80%, or 90% or more of an Fc region containing the amino acid modification). In some embodiments, the polypeptide variant comprises a CH2 or CH3 region. In some embodiments, the compositions comprise an amino acid sequence comprising SEQ ID NO:30. In other embodiments, the compositions comprise a nucleic

acid sequence comprising SEQ ID NO:42, or the complement thereof, or sequences that bind to SEQ ID NO:42 under conditions of high stringency. In further embodiments, the present invention provides host cells (e.g. CHO cells) and vectors comprising SEQ ID NO:42. In additional embodiments, the present invention provides a computer readable
5 medium, wherein the computer readable medium encodes a representation of SEQ ID NO:30 or 42.

In some embodiments, the polypeptide variant comprises an antibody. In other embodiments, the parent polypeptide comprises a human IgG Fc region. In other
10 embodiments, the parent polypeptide comprises a human IgG1, IgG2, IgG3, or IgG4 Fc region. In particular embodiments, the parent polypeptide comprises an amino acid sequence selected from SEQ ID NO:15, SEQ ID NO:16, SEQ ID NO:17, SEQ ID NO:18, SEQ ID NO:19, SEQ ID NO:20, SEQ ID NO:21, SEQ ID NO:22, SEQ ID NO:23, SEQ ID NO:24, SEQ ID NO:25 and SEQ ID NO:48.

In other embodiments, the polypeptide variant comprises a second, third, fourth, etc,
15 amino acid modification in the Fc region (See, e.g., Tables 1 and 2 below). In preferred embodiments, the variant is a CHO-expressed polypeptide.

In certain embodiments, the present invention provides compositions comprising a variant of a parent polypeptide having at least a portion of an Fc region, wherein the variant binds an FcγRIII with higher affinity, and FcγRIIb with lower affinity, than the parent
20 polypeptide and comprises a S298V amino acid modification in the Fc region. In particular embodiments, the present invention provides compositions comprising a variant of a parent polypeptide having at least a portion of an Fc region, wherein the variant interacts with an FcγRIII with a higher assay signal, and FcγRIIb with a lower assay signal, than the parent polypeptide and comprises a S298V amino acid modification in the Fc region. In some
25 embodiments, the present invention provides methods comprising a) providing; i) a composition comprising a variant of a parent polypeptide having at least a portion of an Fc region, wherein the variant binds an FcγRIII with higher affinity, and FcγRIIb with lower affinity, than the parent polypeptide and comprises a S298V amino acid modification in the Fc region, and ii) a subject with one or more symptoms of a disease, and b) administering
30 the composition to the subject under conditions such that at least one of the symptoms is reduced. In additional embodiments, the present invention provides methods comprising a) providing; i) a composition comprising a variant of a parent polypeptide having at least a portion of an Fc region, wherein the variant interacts with an FcγRIII with a higher assay signal, and FcγRIIb with a lower assay signal, than the parent polypeptide and comprises a

S298V amino acid modification in the Fc region, and ii) a subject with one or more symptoms of a disease, and b) administering the composition to the subject under conditions such that at least one of the symptoms is reduced. In certain embodiments, the polypeptide variant comprises an antibody or immunoadhesin, and the subject has symptoms of an antibody or immunoadhesin responsive disease.

In certain embodiments, the compositions comprise a variant of a parent polypeptide having at least a portion of an Fc region, wherein the variant mediates antibody-dependent cell-mediated cytotoxicity (ADCC) in the presence of effector cells less effectively than the parent polypeptide and comprises a S298V amino acid modification in the Fc region.

In other embodiments, the compositions comprise a polypeptide comprising a variant Fc region wherein the polypeptide binds an FcγRIII with higher affinity, and FcγRIIb with lower affinity, than the parent polypeptide and comprises a S298V amino acid modification in the Fc region. In some embodiments, the compositions comprise a polypeptide comprising a variant Fc region wherein the polypeptide interacts with an FcγRIII with a higher assay signal, and FcγRIIb with a lower assay signal, than the parent polypeptide and comprises a S298V amino acid modification in the Fc region. In particular embodiments, the compositions comprise a nucleic acid sequence encoding a variant of a parent polypeptide comprising at least a portion of an Fc region, wherein the variant binds an FcγRIII with higher affinity, and FcγRIIb with lower affinity, than the parent polypeptide, and/or the variant interacts with an FcγRIII with a higher assay signal, and FcγRIIb with a lower assay signal, than the parent polypeptide and comprises a S298V amino acid modification in the Fc region; and/or mediates antibody-dependent cell-mediated cytotoxicity (ADCC) in the presence of effector cells less effectively than the parent polypeptide, and comprises a S298V amino acid modification in the Fc region. In some embodiments, the compositions comprise a nucleic acid sequence encoding a variant Fc polypeptide which binds an FcγRIII with higher affinity, and FcγRIIb with lower affinity, than the parent polypeptide; and/or the variant interacts with an FcγRIII with a higher assay signal, and FcγRIIb with a lower assay signal, than the parent polypeptide and comprises a S298V amino acid modification in the Fc region; and/or mediates antibody-dependent cell-mediated cytotoxicity (ADCC) in the presence of effector cells less effectively than the parent polypeptide, and comprises a S298V amino acid modification in the Fc region.

In certain embodiments, the variant comprises at least a portion of the Fc region (e.g. 40%, 50%, 60%, 80%, or 90% or more of an Fc region containing the amino acid

modification). In some embodiments, the variants comprises a CH2 or CH3 region. In particular embodiments, the compositions comprise an amino acid sequence comprising SEQ ID NO:31. In other embodiments, the compositions comprise a nucleic acid sequence comprising SEQ ID NO:43, or the complement thereof, or sequences that bind to SEQ ID NO:43 under conditions of high stringency. In further embodiments, the present invention provides host cells (e.g. CHO cells) and vectors comprising SEQ ID NO:43. In still further embodiments, the present invention provides a computer readable medium, wherein the computer readable medium encodes a representation of SEQ ID NO:31 or 43.

In some embodiments, the polypeptide variant comprises an antibody. In other embodiments, the parent polypeptide comprises a human IgG Fc region. In particular embodiments, the parent polypeptide comprises a human IgG1, IgG2, IgG3, or IgG4 Fc region. In other embodiments, the parent polypeptide comprises an amino acid sequence selected from SEQ ID NO:15, SEQ ID NO:16, SEQ ID NO:17, SEQ ID NO:18, SEQ ID NO:19, SEQ ID NO:20, SEQ ID NO:21, SEQ ID NO:22, SEQ ID NO:23, SEQ ID NO:24, SEQ ID NO:25 and SEQ ID NO:48.

In some embodiments, the variant comprises a second amino acid modification in the Fc region (See, e.g., Tables 1 and 2 below). In other embodiments, the variant is a CHO-expressed polypeptide.

In some embodiments, the present invention provides compositions comprising a variant of a parent polypeptide having at least a portion of an Fc region, wherein the variant binds an FcγRIII with higher affinity, and FcγRIIb with lower affinity, than the parent polypeptide and comprises a S298D amino acid modification in the Fc region. In other embodiments, the present invention provides compositions comprising a variant of a parent polypeptide having at least a portion of an Fc region, wherein the variant interacts with an FcγRIII with a higher assay signal, and FcγRIIb with a lower assay signal, than the parent polypeptide and comprises a S298D amino acid modification in the Fc region. In other embodiments, the present invention provides methods comprising; a) providing; i) a composition comprising a variant of a parent polypeptide having at least a portion of an Fc region, wherein the variant binds an FcγRIII with higher affinity, and FcγRIIb with lower affinity, than the parent polypeptide and comprises a S298D amino acid modification in the Fc region, and ii) a subject with one or more symptoms of disease, and b) administering the composition to the subject under conditions such that at least one of the symptoms are reduced. In particular embodiments, the present invention provides methods comprising; a) providing; i) a composition comprising a variant of a parent polypeptide having at least a

portion of an Fc region, wherein the variant interacts with an FcγRIII with a higher assay signal, and FcγRIIb with a lower assay signal, than the parent polypeptide and comprises a S298D amino acid modification in the Fc region, and ii) a subject with one or more symptoms of disease, and b) administering the composition to the subject under conditions
5 such that at least one of the symptoms are reduced. In additional embodiments, the polypeptide variant comprises an antibody or immunoadhesin, and the subject has symptoms of an antibody or immunoadhesin responsive disease.

In certain embodiments, the compositions comprise a variant of a parent polypeptide having at least a portion of an Fc region, wherein the variant mediates antibody-dependent
10 cell-mediated cytotoxicity (ADCC) in the presence of effector cells less effectively than the parent polypeptide and comprises a S298D amino acid modification in the Fc region. In other embodiments, the compositions comprise a polypeptide comprising a variant Fc region wherein the polypeptide binds an FcγRIII with higher affinity, and FcγRIIb with lower affinity, than the parent polypeptide and comprises a S298D amino acid modification
15 in the Fc region.

In some embodiments, the compositions comprise a nucleic acid sequence encoding a variant of a parent polypeptide having at least a portion of an Fc region, wherein the variant binds an FcγRIII with higher affinity, and FcγRIIb with lower affinity, than the parent polypeptide, and/or the variant interacts with an FcγRIII with a higher assay signal,
20 and FcγRIIb with a lower assay signal, than the parent polypeptide; and/or mediates antibody-dependent cell-mediated cytotoxicity (ADCC) in the presence of effector cells less effectively than the parent polypeptide, and comprises a S298D amino acid modification in the Fc region. In certain embodiments, the compositions comprise a nucleic acid sequence encoding a variant Fc polypeptide which binds an FcγRIII with higher affinity, and FcγRIIb
25 with lower affinity, than the parent polypeptide, and/or a variant Fc polypeptide which interacts with an FcγRIII with a higher assay signal, and FcγRIIb with a lower assay signal, than the parent polypeptide; and/or mediates antibody-dependent cell-mediated cytotoxicity (ADCC) in the presence of effector cells less effectively than the parent polypeptide, and comprises a S298D amino acid modification in the Fc region.

In certain embodiments, the variant comprises at least a portion of the Fc region (e.g. 40%, 50%, 60%, 80%, or 90% or more of an Fc region containing the amino acid modification). In some embodiments, the variants comprises a CH2 or CH3 region. In other embodiments, the compositions comprise an amino acid sequence comprising SEQ ID
30 NO:32. In some embodiments, the compositions comprise a nucleic acid sequence

comprising SEQ ID NO:44, or the complement thereof, or sequences that bind to SEQ ID NO:44 under conditions of high stringency. In further embodiments, the present invention provides host cells (e.g., CHO cells) and vectors comprising SEQ ID NO:44. In additional embodiments, the present invention provides a computer readable medium, wherein the
5 computer readable medium encodes a representation of SEQ ID NO:32 or 44.

In some embodiments, the polypeptide variant comprises an antibody. In certain embodiments, the parent polypeptide comprises a human IgG Fc region. In other embodiments, the parent polypeptide comprises a human IgG1, IgG2, IgG3, or IgG4 Fc region. In particular embodiments, the parent polypeptide comprises an amino acid
10 sequence selected from SEQ ID NO:15, SEQ ID NO:16, SEQ ID NO:17, SEQ ID NO:18, SEQ ID NO:19, SEQ ID NO:20, SEQ ID NO:21, SEQ ID NO:22, SEQ ID NO:23, SEQ ID NO:24, SEQ ID NO:25 and SEQ ID NO:48.

In other embodiments, the variant comprises a second, third, fourth, etc., amino acid modification in the Fc region (See, e.g., Tables 1 and 2 below). In some embodiments, the
15 variant is a CHO-expressed polypeptide.

In some embodiments, the present invention provides compositions comprising a variant of a parent polypeptide having at least a portion of an Fc region, wherein the variant has a relative binding affinity, or relative assay signal, for FcγRIII or FcγRIIb that is approximately 0.25 or less as measured in an ELISA FcγR binding assay, and wherein the
20 variant comprises at least one amino acid modification at position 298 of the Fc region. In other embodiments, the present invention provides methods comprising; a) providing; i) a composition comprising a variant of a parent polypeptide having at least a portion of an Fc region, wherein the variant has a relative binding affinity, or a relative assay signal, for FcγRIII or FcγRIIb that is approximately 0.25 or less as measured in an ELISA FcγR
25 binding assay, and wherein the variant comprises at least one amino acid modification at position 298 of the Fc region, and ii) a subject with one or more symptoms of a disease, and b) administering the composition to the subject under conditions such that at least one of the symptoms are reduced. In certain embodiments, the polypeptide variant comprises an antibody or immunoadhesin, and the subject has symptoms of an antibody or
30 immunoadhesin responsive disease.

In particular embodiments, the variant has a relative binding affinity, or a relative assay signal, for FcγRIII or FcγRIIb that is approximately 0.10 or less as measured in an ELISA FcγR binding assay. In other embodiments, the variant has a relative binding affinity, or relative assay signal, for FcγRIII or FcγRIIb that is approximately 0.0 as

measured in an ELISA FcγR binding assay. In preferred embodiments, the at least one amino acid modification at position 298 is S298P.

In some embodiments, the present invention provides compositions comprising a polypeptide comprising a variant Fc region, wherein the polypeptide has a relative binding
5 affinity, or relative assay signal, for FcγRIII or FcγRIIb that is approximately 0.25 or less (e.g. a relative binding affinity, or relative assay signal, of 0.15, 0.10, 0.05, 0.0) as measured in an ELISA FcγR binding assay, and wherein the variant comprises at least one amino acid modification at position 298 of the Fc region (e.g. S298P). In other
10 embodiments, the compositions comprise a nucleic acid sequence encoding a variant of a parent polypeptide having at least a portion of an Fc region, wherein the variant has a relative binding affinity, or relative assay signal, for FcγRIII or FcγRIIb that is approximately 0.25 or less as measured in an ELISA FcγR binding assay, and wherein the variant comprises at least one amino acid modification at position 298 of the Fc region (e.g., S298P). In certain embodiments, the compositions comprise a nucleic acid sequence
15 encoding a variant Fc polypeptide which has a relative binding affinity, or relative assay signal, for FcγRIII or FcγRIIb that is approximately 0.25 or less as measured in an ELISA FcγR binding assay, and wherein the variant comprises at least one amino acid modification at position 298 of the Fc region (e.g., S298P).

In particular embodiments, the variant comprises at least a portion of the Fc region
20 (e.g. 40%, 50%, 60%, 80%, or 90% or more of an Fc region containing the amino acid modification). In some embodiments, the variants comprises a CH2 or CH3 region. In further embodiments, the compositions comprise an amino acid sequence comprising SEQ ID NO:34. In other embodiments, the compositions comprise a nucleic acid sequence comprising SEQ ID NO:46, or the complement thereof, or sequences that bind to SEQ ID
25 NO:46 under conditions of high stringency. In some embodiments, the compositions comprise host cells (e.g. CHO host cells) and vectors comprising SEQ ID NO:46. In certain embodiments, the present invention provides a computer readable medium, wherein the computer readable medium encodes a representation of SEQ ID NO:34 or 46.

In some embodiments, the polypeptide variant comprises an antibody. In other
30 embodiments, the parent polypeptide comprises a human IgG Fc region. In particular embodiments, the parent polypeptide comprises a human IgG1, IgG2, IgG3, or IgG4 Fc region. In particular embodiments, the parent polypeptide comprises an amino acid sequence selected from SEQ ID NO:15, SEQ ID NO:16, SEQ ID NO:17, SEQ ID NO:18,

SEQ ID NO:19, SEQ ID NO:20, SEQ ID NO:21, SEQ ID NO:22, SEQ ID NO:23, SEQ ID NO:24, SEQ ID NO:25 and SEQ ID NO:48.

In further embodiments, the polypeptide variant comprises a second, third, fourth, etc., amino acid modification in the Fc region (See, e.g. Tables 1 and 2 below). In certain
5 embodiments, the variant is a CHO-expressed polypeptide.

In certain embodiments, the variants of the present invention, and the nucleic acid sequences encoding the variants, are provided with at least one other component in a kit. For example, a kit may comprise at least one type of variant, and written instructions for using the variant. The kit may also contain buffers, and other useful reagents.

10 In some embodiments, the present invention provides methods comprising, a) providing; i) a solid surface, ii) a composition comprising a variant of a parent polypeptide having at least a portion of an Fc region, wherein the variant comprises at least one amino acid modification in the Fc region, and iii) an Fc receptor or portion thereof, wherein the Fc receptor is selected from Fc γ RIII, Fc γ RIIb, and Fc γ RIIa, and b) contacting the solid surface
15 with the composition under-conditions such that the variant binds to the solid surface (e.g. via a ligand bound to the solid surface) thereby generating bound variant, c) incubating the Fc receptor and the bound variant, and d) measuring binding of the bound variant for the Fc receptor. In preferred embodiments, the Fc receptors is provided in high concentrations (e.g. in the micromolar range). In other preferred embodiments, the Fc receptor is provided
20 at a concentration of 1-10 micromolar. In further preferred embodiments, the Fc receptor is provided in a concentration in excess of the K_d value of the reaction. In other embodiments, the Fc receptor is labelled (e.g. with biotin).

In other embodiments, the present invention provides methods comprising, a) providing; i) a composition comprising a variant of a parent polypeptide having at least a
25 portion of an Fc region, wherein the variant comprises at least one amino acid modification in the Fc region, and ii) an Fc receptor or portion thereof, wherein the Fc receptor is selected from Fc γ RIII, Fc γ RIIb, and Fc γ RIIa, and b) incubating the Fc receptor and the bound variant, and c) measuring affinity of the bound variant for the Fc receptor. In preferred embodiments, the Fc receptors is provided in high concentrations (e.g. in the micromolar range). In other preferred embodiments, the Fc receptor is provided at a concentration of 1-
30 10 micromolar. In further preferred embodiments, the Fc receptor is provided in a concentration in excess of the K_d value of the reaction. In other embodiments, the Fc receptor is labelled (e.g. with biotin).

In other embodiments, the present invention provides methods comprising; a) providing; i) a solid surface comprising a ligand, ii) a composition comprising a variant of a parent polypeptide having at least a portion of an Fc region, wherein the variant comprises at least one amino acid modification in the Fc region, and wherein the variant specifically
5 binds the ligand, and iii) an Fc receptor or portion thereof, wherein the Fc receptor is selected from Fc γ RIII, Fc γ RIIb, and Fc γ RIIa, and b) contacting the solid surface with the composition under conditions such that the variant binds to the ligand thereby generating bound variant, c) incubating the Fc receptor and the bound variant, and d) measuring
10 binding of the bound variant for the Fc receptor. In preferred embodiments, the Fc receptors is provided in high concentrations (e.g. in the micromolar range). In other preferred embodiments, the Fc receptor is provided at a concentration of 1-10 micromolar. In further preferred embodiments, the Fc receptor is provided in a concentration in excess of the K_d value of the reaction. In other embodiments, the Fc receptor is labelled (e.g. with biotin).

15 In certain embodiments, the variant comprises an antibody or portion thereof. In other embodiments, the antibody is IgG (e.g. monomeric IgG). In some embodiments, the Fc receptor comprises a label. In additional embodiments, the method further comprises a step before step d), but after step c) of adding a detectable molecule configured to bind the label (or the Fc receptor), wherein the detectable molecule comprises a secondary label. In
20 particular embodiments, the detectable molecule comprises an avidin molecule conjugated to an enzyme (e.g. phosphatase). In some embodiments, the label comprises biotin.

It is not intended that the above-described methods be limited by the nature of the Fc receptor. In certain embodiments, the Fc receptor is an Fc neonatal receptor instead of being selected from Fc γ RIII, Fc γ RIIb, or Fc γ RIIa. In some embodiments, the composition
25 comprises a plurality of different types of variants, and the method further comprises the step e) identifying variants that bind the Fc receptor with greater affinity than the parent polypeptide. In other embodiments, the composition comprises a plurality of different types of variants, and the method further comprises step e) identifying variants that bind the Fc receptor with less affinity than the parent polypeptide. In particular embodiments, the
30 method further comprises a step of washing the solid surface after step b) or step c), or both steps b) and c). In particular embodiments, the method further comprises a step of blocking the solid surface before or after step b (e.g. to occupy remaining binding sites on the solid surface).

In some embodiments, the present invention provides methods of identifying dual-species improved variants, comprising; a) providing; i) target cells, ii) a composition comprising a candidate variant of a parent polypeptide having an Fc region, wherein the candidate variant comprises at least one amino acid modification in the Fc region, and
5 wherein the candidate variant mediates target cell cytotoxicity in the presence of a first species of effector cells more effectively than the parent polypeptide, and iii) second species effector cells, and b) incubating the composition with the target cells under conditions such that the candidate variant binds the target cells thereby generating candidate variant bound target cells, c) mixing the second species effector cells with the candidate variant bound
10 target cells, d) measuring target cell cytotoxicity (e.g. mediated by the candidate variant), e) determining if the candidate variant mediates target cell cytotoxicity in the presence of the second species effector cells more effectively than the parent polypeptide. In some embodiments, the method further comprises screening the parent polypeptide in the same fashion with the second species effector cells. In further embodiments, steps b) and c) are
15 performed simultaneously. In particular embodiments, the method further comprises step f) identifying a candidate variant as a dual-species improved variant that mediates target cell cytotoxicity in the presence of the second species effector cells more effectively than the parent polypeptide. In other embodiments, the method further comprises step f) identifying a candidate variant as a dual-species improved variant that mediates target cell cytotoxicity
20 in the presence of the second species effector cells about 1.5 times (or about 5 times, or about 10 times) more effectively than the parent polypeptide (e.g. about 1.5 times more target cell lysis is observed).

In other embodiments, the present invention provides methods of identifying dual-species improved variants, comprising; a) providing; i) target cells, ii) a composition
25 comprising a candidate variant of a parent polypeptide having an Fc region, wherein the candidate variant comprises at least one amino acid modification in the Fc region, iii) first species effector cells, and iv) second species effector cells, and b) incubating the composition with the target cells under conditions such that the candidate variant binds the target cells thereby generating candidate variant bound target cells, c) mixing the first
30 species effector cells with the candidate variant bound target cells, d) measuring target cell cytotoxicity (e.g. mediated by the candidate variant), e) determining that the candidate variant mediates target cell cytotoxicity in the presence of the first species effector cells more effectively than the parent polypeptide, f) mixing the second species effector cells with the candidate variant bound target cells (e.g. as generated in step b), g) measuring

target cell cytotoxicity (e.g. mediated by the candidate variant), h) determining if the candidate variant mediates target cell cytotoxicity in the presence of the second species effector cells more effectively than the parent polypeptide.

5 In particular embodiments, the method further comprises a step to determine the ability of the parent polypeptide to mediate target cell cytotoxicity in the presence of the first species and/or the second species. For example, the methods may further comprise mixing the first or second species effector cells with parent polypeptide bound target cells, and then measuring target cell cytotoxicity (e.g. determining a value such that there is a value to compare the variants against).

10 In certain embodiments, the method further comprises step g) administering the dual-species improved variant to a test animal, wherein the test animal is a member of the second species. In other embodiments, the method further comprises, prior to step a), a step of screening the candidate variant in an Fc receptor (FcR) binding assay. In some embodiments, the FcR binding assay is an ELISA assay. In particular embodiments, the
15 FcR binding assay, is an Fc γ RIII binding assay. In other embodiments, the FcR binding assay is an Fc γ RIIb binding assay. In further embodiments, the FcR binding assay is an Fc γ RIIa binding assay. In certain embodiments, the FcR binding assay is an Fc neonatal receptor (FcRn) binding assay.

In some embodiments, the method further comprises, prior to step a), a step of
20 screening the candidate variant in a C1q binding assay (See, e.g., section IV below). In other embodiments, the method further comprises, prior to step a), a step of screening the candidate variant in a complement dependent cytotoxicity (CDC) assay (See, e.g., section IV below). In particular embodiments, the method further comprises, prior to step a) a step of calculating the specificity ratio for the candidate variant. In some embodiments, the first
25 species of effector cells are human PBMCs. In other embodiments, the first species of effector cells are mouse PBMCs or rat PBMCs. In certain embodiments, the second species of effector cells are mouse PBMCs or rat PBMCs. In particular embodiments, the second species of effector cells are human PBMCs.

In some embodiments, the present invention provides methods of identifying dual-
30 species improved variants, comprising; a) providing; i) a composition comprising a candidate variant of a parent polypeptide having an Fc region, wherein the candidate variant comprises at least one amino acid modification in the Fc region, and wherein the candidate variant binds a first species of C1q peptides more effectively than the parent polypeptide, and iii) a second species of C1q peptides, and b) incubating the composition with the second

species of Clq peptides; and c) determining if the candidate variant binds the second species of Clq peptides more effectively than the parent polypeptide. In particular embodiments, the method further comprises step d) identifying a candidate variant as a dual-species improved variant.

5 In some embodiments, the target cells are human cells (e.g. over-expressing one or more of the following tumor-associated antigens: CD20, CD22, CD33, CD40, CD63, EGF receptor, her-2 receptor, prostate-specific membrane antigen, Lewis Y carbohydrate, GD₂ and GD₃ gangliosides, lamp-1, CO-029, L6, and ephA2). In certain embodiments, the variant comprises an antibody, or portion thereof, specific for the target cells. In other
10 embodiments, the candidate variant mediates target cell cytotoxicity in the presence of the first species of effector cells about 1.5 times more effectively than the parent polypeptide. In some embodiments, step e) comprises performing a control reaction with the parent polypeptide. In additional embodiments, the measuring comprises quantitating target cell death or target cell lysis. In other embodiments, the target cells infected with viruses (e.g.
15 HIV, CMV, hepatitis B, or RSV, for example) or microbial organisms (e.g. Staphylococcus, Streptococcus, Pseudomonas, etc). In certain embodiments, the target cells are microbial organisms (e.g. Staphylococcus, Streptococcus, Pseudomonas, etc). In some embodiments, the target cells are replaced instead with viruses (e.g. HIV, CMV, hepatitis B, or RSV).

 In some embodiments, the present invention provides compositions comprising a
20 polypeptide, wherein the polypeptide comprises; i) an unmodified human framework (e.g. no alterations have been made to a naturally occurring human framework), and ii) a variant Fc region. In certain embodiments, the unmodified human framework is a human germline framework. In other embodiments, the present invention provides compositions comprising a polypeptide, wherein the polypeptide comprises: i) at least one randomized CDR sequence
25 and ii) a variant Fc region. In further embodiments, the present invention provides compositions comprising a polypeptide, wherein the polypeptide comprises; i) an unmodified human framework (e.g. human germline framework), ii) at least one randomized CDR sequence, and iii) a variant Fc region.

30

DESCRIPTION OF THE FIGURES

Figure 1 shows a schematic representation of an IgG molecule with the various regions and sections labeled.

Figure 2 shows an alignment of various parental IgG amino acid sequences, including human IgG1 (with non-A (SEQ ID NO:15) and A allotypes shown), human IgG2 (SEQ ID NO:16), human IgG3 (SEQ ID NO:17), human IgG4 (SEQ ID NO:18), murine IgG1 (SEQ ID NO:19), murine IgG2A (SEQ ID NO:20), murine IgG2B (SEQ ID NO:21), and murine IgG3 (SEQ ID NO:22).

Figure 3 shows various amino acid sequences, including the CH2 region (SEQ ID NO:23), and CH3 region (SEQ ID NO:24) of human IgG1, as well as a non-A allotype (SEQ ID NO:25) and A allotype (SEQ ID NO:48) sequences of human IgG1 that include the CH1, hinge, CH2 and CH3 regions.

Figure 4 shows various variant amino acid sequences.

Figure 5 shows two nucleotide sequences encoding parental polypeptides.

Figure 6 shows various nucleic acid sequences encoding certain variants.

Figure 7 shows the results of FcγRIIb binding assays with CHO and 293 expressed S298D variants compared to CHO and 293 expressed parental peptides.

Figure 8 shows the results of FcγRIII binding assays with CHO and 293 expressed S298D variants compared to CHO and 293 expressed parental peptides.

Figure 9 shows the results of an ADCC assay comparing the wild type Fc region with the S298N and S298V variants.

Figure 10 shows the results of an ADCC assay comparing the wild type Fc region with the D280H and S298D variants.

Figure 11 shows the results of an ADCC assay comparing the wild type Fc region with the K290S variant.

Figure 12 shows various CH2 region nucleic acid and amino acid sequences for the D280H and K290S variants.

Figure 13 shows various variant amino acid sequences, including SEQ ID NOs:49, 50, and 55-63.

30

DEFINITIONS

To facilitate an understanding of the invention, a number of terms are defined below.

As used herein, the terms "subject" and "patient" refer to any animal, such as a mammal like a dog, cat, bird, livestock, and preferably a human (e.g. a human with a disease).

As used herein, the terms "nucleic acid molecule encoding," "DNA sequence encoding," and "DNA encoding" refer to the order or sequence of deoxyribonucleotides along a strand of deoxyribonucleic acid. The order of these deoxyribonucleotides determines the order of amino acids along the polypeptide (protein) chain. The DNA sequence thus codes for the amino acid sequence.

DNA molecules are said to have "5' ends" and "3' ends" because mononucleotides are reacted to make oligonucleotides or polynucleotides in a manner such that the 5' phosphate of one mononucleotide pentose ring is attached to the 3' oxygen of its neighbor in one direction via a phosphodiester linkage. Therefore, an end of an oligonucleotides or polynucleotide, referred to as the "5' end" if its 5' phosphate is not linked to the 3' oxygen of a mononucleotide pentose ring and as the "3' end" if its 3' oxygen is not linked to a 5' phosphate of a subsequent mononucleotide pentose ring. As used herein, a nucleic acid sequence, even if internal to a larger oligonucleotide or polynucleotide, also may be said to have 5' and 3' ends. In either a linear or circular DNA molecule, discrete elements are referred to as being "upstream" or 5' of the "downstream" or 3' elements. This terminology reflects the fact that transcription proceeds in a 5' to 3' fashion along the DNA strand. The promoter and enhancer elements that direct transcription of a linked gene are generally located 5' or upstream of the coding region. However, enhancer elements can exert their effect even when located 3' of the promoter element and the coding region. Transcription termination and polyadenylation signals are located 3' or downstream of the coding region.

As used herein, the term "codon" or "triplet" refers to a tuplet of three adjacent nucleotide monomers which specify one of the twenty naturally occurring amino acids found in polypeptide biosynthesis. The term also includes nonsense codons which do not specify any amino acid.

As used herein, the terms "an oligonucleotide having a nucleotide sequence encoding a polypeptide", "polynucleotide having a nucleotide sequence encoding a polypeptide", and "nucleic acid sequence encoding a polypeptide" means a nucleic acid sequence comprising the coding region of a particular polypeptide. The coding region may be present in a cDNA, genomic DNA, or RNA form. When present in a DNA form, the oligonucleotide or polynucleotide may be single-stranded (*i.e.*, the sense strand) or double-

stranded. Suitable control elements such as enhancers/promoters, splice junctions, polyadenylation signals, etc. may be placed in close proximity to the coding region of the gene if needed to permit proper initiation of transcription and/or correct processing of the primary RNA transcript. Alternatively, the coding region utilized in the expression vectors
5 of the present invention may contain endogenous enhancers/promoters, splice junctions, intervening sequences, polyadenylation signals, *etc.* or a combination of both endogenous and exogenous control elements.

As used herein, the terms "complementary" or "complementarity" are used in reference to polynucleotides (*i.e.*, a sequence of nucleotides) related by the base-pairing
10 rules. For example, for the sequence "A-G-T," is complementary to the sequence "T-C-A." Complementarity may be "partial," in which only some of the nucleic acids' bases are matched according to the base pairing rules. Or, there may be "complete" or "total" complementarity between the nucleic acids. The degree of complementarity between nucleic acid strands has significant effects on the efficiency and strength of hybridization
15 between nucleic acid strands. This is of particular importance in amplification reactions, as well as detection methods that depend upon binding between nucleic acids.

As used herein, the term "the complement of" a given sequence is used in reference to the sequence that is completely complementary to the sequence over its entire length. For example, the sequence A-G-T-A is "the complement" of the sequence T-C-A-T.

20 The term "homology" (when in reference to nucleic acid sequences) refers to a degree of complementarity. There may be partial homology or complete homology (*i.e.*, identity). A partially complementary sequence is one that at least partially inhibits a completely complementary sequence from hybridizing to a target nucleic acid and is referred to using the functional term "substantially homologous." The term "inhibition of
25 binding," when used in reference to nucleic acid binding, refers to inhibition of binding caused by competition of homologous sequences for binding to a target sequence. The inhibition of hybridization of the completely complementary sequence to the target sequence may be examined using a hybridization assay (Southern or Northern blot, solution hybridization and the like) under conditions of low stringency. A substantially homologous
30 sequence or probe will compete for and inhibit the binding (*i.e.*, the hybridization) of a completely homologous sequence to a target under conditions of low stringency. This is not to say that conditions of low stringency are such that non-specific binding is permitted; low stringency conditions require that the binding of two sequences to one another be a specific (*i.e.*, selective) interaction. The absence of non-specific binding may be tested by the use of

a second target that lacks even a partial degree of complementarity (*e.g.*, less than about 30% identity); in the absence of non-specific binding the probe will not hybridize to the second non-complementary target.

The art knows well that numerous equivalent conditions may be employed to
5 comprise low stringency conditions; factors such as the length and nature (DNA, RNA, base composition) of the probe and nature of the target (DNA, RNA, base composition, present in solution or immobilized, etc.) and the concentration of the salts and other components (*e.g.*, the presence or absence of formamide, dextran sulfate, polyethylene glycol) are considered and the hybridization solution may be varied to generate conditions of low
10 stringency hybridization different from, but equivalent to, the above listed conditions. In addition, the art knows conditions that promote hybridization under conditions of high stringency (*e.g.*, increasing the temperature of the hybridization and/or wash steps, the use of formamide in the hybridization solution, etc.).

A nucleic acid sequence (*e.g.* encoding a variant Fc region or portion thereof) may
15 produce multiple RNA species that are generated by differential splicing of the primary RNA transcript. cDNAs that are splice variants of the same gene will contain regions of sequence identity or complete homology (representing the presence of the same exon or portion of the same exon on both cDNAs) and regions of complete non-identity (for example, representing the presence of exon "A" on cDNA 1 wherein cDNA 2 contains exon
20 "B" instead). Because the two cDNAs contain regions of sequence identity they will both hybridize to a probe derived from the entire gene or portions of the gene containing sequences found on both cDNAs; the two splice variants are therefore substantially homologous to such a probe and to each other.

When used in reference to a single-stranded nucleic acid sequence, the term
25 "substantially homologous" refers to any probe that can hybridize (*i.e.*, it is the complement of) the single-stranded nucleic acid sequence under conditions of low stringency.

As used herein, the term "hybridization" is used in reference to the pairing of complementary nucleic acids. Hybridization and the strength of hybridization (*i.e.*, the strength of the association between the nucleic acids) is impacted by such factors as the
30 degree of complementary between the nucleic acids, stringency of the conditions involved, the T_m of the formed hybrid, and the G:C ratio within the nucleic acids.

As used herein, the term " T_m " is used in reference to the "melting temperature."
The melting temperature is the temperature at which a population of double-stranded

nucleic acid molecules becomes half dissociated into single strands. The equation for calculating the T_m of nucleic acids is well known in the art. As indicated by standard references, a simple estimate of the T_m value may be calculated by the equation: $T_m = 81.5 + 0.41(\% G + C)$, when a nucleic acid is in aqueous solution at 1 M NaCl (*See e.g.*,
5 Anderson and Young, Quantitative Filter Hybridization, *in Nucleic Acid Hybridization* [1985]). Other references include more sophisticated computations that take structural as well as sequence characteristics into account for the calculation of T_m , and in some cases the T_m may be determined empirically by beginning with the calculated T_m and testing small increases or decreases of temperature and examining the effect on the population of
10 nucleic acid molecules.

As used herein the term "stringency" is used in reference to the conditions of temperature, ionic strength, and the presence of other compounds such as organic solvents, under which nucleic acid hybridizations are conducted. Those skilled in the art will recognize that "stringency" conditions may be altered by varying the parameters just
15 described either individually or in concert. With "high stringency" conditions, nucleic acid base pairing will occur only between nucleic acid fragments that have a high frequency of complementary base sequences (*e.g.*, hybridization under "high stringency" conditions may occur between homologs with about 85-100% identity, preferably about 70-100% identity). With medium stringency conditions, nucleic acid base pairing will occur between nucleic
20 acids with an intermediate frequency of complementary base sequences (*e.g.*, hybridization under "medium stringency" conditions may occur between homologs with about 50-70% identity). Thus, conditions of "weak" or "low" stringency are often required with nucleic acids that are derived from organisms that are genetically diverse, as the frequency of complementary sequences is usually less.

"High stringency conditions" when used in reference to nucleic acid hybridization comprise conditions equivalent to binding or hybridization at 42 °C in a solution consisting of 5X SSPE (43.8 g/l NaCl, 6.9 g/l NaH₂PO₄ H₂O and 1.85 g/l EDTA, pH adjusted to 7.4 with NaOH), 0.5% SDS, 5X Denhardt's reagent and 100 µg/ml denatured salmon sperm DNA followed by washing in a solution comprising 0.1X SSPE, 1.0% SDS at 42 °C when a
30 probe of about 500 nucleotides in length is employed.

"Medium stringency conditions" when used in reference to nucleic acid hybridization comprise conditions equivalent to binding or hybridization at 42°C in a solution consisting of 5X SSPE (43.8 g/l NaCl, 6.9 g/l NaH₂PO₄ H₂O and 1.85 g/l EDTA,

pH adjusted to 7.4 with NaOH), 0.5% SDS, 5X Denhardt's reagent and 100 µg/ml denatured salmon sperm DNA followed by washing in a solution comprising 1.0X SSPE, 1.0% SDS at 42 C when a probe of about 500 nucleotides in length is employed.

"Low stringency conditions" comprise conditions equivalent to binding or
5 hybridization at 42 C in a solution consisting of 5X SSPE (43.8 g/l NaCl, 6.9 g/l NaH₂PO₄ H₂O and 1.85 g/l EDTA, pH adjusted to 7.4 with NaOH), 0.1% SDS, 5X Denhardt's reagent [50X Denhardt's contains per 500 ml: 5 g Ficoll (Type 400, Pharmacia), 5 g BSA (Fraction V; Sigma)] and 100 g/ml denatured salmon sperm DNA followed by washing in a solution comprising 5X SSPE, 0.1% SDS at 42 C when a probe of about 500 nucleotides in
10 length is employed.

The following terms are used to describe the sequence relationships between two or more polynucleotides: "reference sequence", "sequence identity", and "percentage of sequence identity". A "reference sequence" is a defined sequence used as a basis for a sequence comparison; a reference sequence may be a subset of a larger sequence, for
15 example, as a segment of a full-length cDNA sequence given in a sequence listing or may comprise a complete gene sequence. Generally, a reference sequence is at least 20 nucleotides in length, frequently at least 25 nucleotides in length, and often at least 50 nucleotides in length (*e.g.* SEQ ID NO:36 or SEQ ID NO:37 may be used as a reference sequence). Since two polynucleotides may each (1) comprise a sequence (*i.e.*, a portion of
20 the complete polynucleotide sequence) that is similar between the two polynucleotides, and (2) may further comprise a sequence that is divergent between the two polynucleotides, sequence comparisons between two (or more) polynucleotides are typically performed by comparing sequences of the two polynucleotides over a "comparison window" to identify and compare local regions of sequence similarity. A "comparison window", as used herein,
25 refers to a conceptual segment of at least 20 contiguous nucleotide positions wherein a polynucleotide sequence may be compared to a reference sequence of at least 20 contiguous nucleotides and wherein the portion of the polynucleotide sequence in the comparison window may comprise additions or deletions (*i.e.*, gaps) of 20 percent or less as compared to the reference sequence (which does not comprise additions or deletions) for optimal
30 alignment of the two sequences. Optimal alignment of sequences for aligning a comparison window may be conducted by the local homology algorithm of Smith and Waterman [Smith and Waterman, *Adv. Appl. Math.* 2: 482 (1981)] by the homology alignment algorithm of Needleman and Wunsch [Needleman and Wunsch, *J. Mol. Biol.* 48:443 (1970)], by the

search for similarity method of Pearson and Lipman [Pearson and Lipman, *Proc. Natl. Acad. Sci. (U.S.A.)* 85:2444 (1988)], by computerized implementations of these algorithms (GAP, BESTFIT, FASTA, and TFASTA in the Wisconsin Genetics Software Package Release 7.0, Genetics Computer Group, 575 Science Dr., Madison, Wis.), or by inspection, and the best alignment (*i.e.*, resulting in the highest percentage of homology over the comparison window) generated by the various methods is selected. The term "sequence identity" means that two polynucleotide sequences are identical (*i.e.*, on a nucleotide-by-nucleotide basis) over the window of comparison. The term "percentage of sequence identity" is calculated by comparing two optimally aligned sequences over the window of comparison, determining the number of positions at which the identical nucleic acid base (*e.g.*, A, T, C, G, U, or I) occurs in both sequences to yield the number of matched positions, dividing the number of matched positions by the total number of positions in the window of comparison (*i.e.*, the window size), and multiplying the result by 100 to yield the percentage of sequence identity. The window of comparison, as used in the present application, is the entire length of the recited reference sequence (*i.e.* if SEQ ID NO:37 is recited as the reference sequence, percentage of sequence identity is compared over the entire length of SEQ ID NO:37).

As used herein, the term "probe" refers to an oligonucleotide (*i.e.*, a sequence of nucleotides), whether occurring naturally as in a purified restriction digest or produced synthetically, recombinantly or by PCR amplification, that is capable of hybridizing to another oligonucleotide of interest. A probe may be single-stranded or double-stranded. Probes are useful in the detection, identification and isolation of particular gene sequences. It is contemplated that any probe used in the present invention may be labeled with any "reporter molecule," so that is detectable in any detection system, including, but not limited to enzyme (*e.g.*, ELISA, as well as enzyme-based histochemical assays), fluorescent, radioactive, and luminescent systems. It is not intended that the present invention be limited to any particular detection system or label.

As used herein, the term "polymerase chain reaction" ("PCR") refers to the method described in U.S. Patent Nos. 4,683,195, 4,683,202, and 4,965,188, hereby incorporated by reference, that describe a method for increasing the concentration of a segment of a target sequence in a mixture of genomic DNA without cloning or purification. This process for amplifying the target sequence consists of introducing a large excess of two oligonucleotide primers to the DNA mixture containing the desired target sequence, followed by a precise sequence of thermal cycling in the presence of a DNA polymerase. The two primers are

complementary to their respective strands of the double stranded target sequence. To effect amplification, the mixture is denatured and the primers then annealed to their complementary sequences within the target molecule. Following annealing, the primers are extended with a polymerase so as to form a new pair of complementary strands. The steps of denaturation, primer annealing, and polymerase extension can be repeated many times (*i.e.*, denaturation, annealing and extension constitute one "cycle"; there can be numerous "cycles") to obtain a high concentration of an amplified segment of the desired target sequence. The length of the amplified segment of the desired target sequence is determined by the relative positions of the primers with respect to each other, and therefore, this length is a controllable parameter. By virtue of the repeating aspect of the process, the method is referred to as the "polymerase chain reaction" (hereinafter "PCR"). Because the desired amplified segments of the target sequence become the predominant sequences (in terms of concentration) in the mixture, they are said to be "PCR amplified."

With PCR, it is possible to amplify a single copy of a specific target sequence in genomic DNA to a level detectable by several different methodologies (*e.g.*, hybridization with a labeled probe; incorporation of biotinylated primers followed by avidin-enzyme conjugate detection; incorporation of ³²P-labeled deoxynucleotide triphosphates, such as dCTP or dATP, into the amplified segment). In addition to genomic DNA, any oligonucleotide or polynucleotide sequence can be amplified with the appropriate set of primer molecules. In particular, the amplified segments created by the PCR process itself are, themselves, efficient templates for subsequent PCR amplifications.

The term "isolated" when used in relation to a nucleic acid, as in "an isolated oligonucleotide" or "isolated polynucleotide" refers to a nucleic acid sequence that is identified and separated from at least one contaminant nucleic acid with which it is ordinarily associated in its natural source. Isolated nucleic acid is present in a form or setting that is different from that in which it is found in nature. Isolated nucleic acid molecules therefore are distinguished from the nucleic acid molecule as it exists in natural cells. However, an isolated nucleic acid molecule includes a nucleic acid molecule contained in cells that ordinarily express the polypeptide where, for example, the nucleic acid molecule is in a chromosomal location different from that of natural cells. The isolated nucleic acid, oligonucleotide, or polynucleotide may be present in single-stranded or double-stranded form. When an isolated nucleic acid, oligonucleotide or polynucleotide is to be utilized to express a protein, the oligonucleotide or polynucleotide will contain at a minimum the sense or coding strand (*i.e.*, the oligonucleotide or polynucleotide may single-

stranded), but may contain both the sense and anti-sense strands (*i.e.*, the oligonucleotide or polynucleotide may be double-stranded).

As used herein the terms "portion" when used in reference to a nucleotide sequence (as in "a portion of a given nucleotide sequence") refers to fragments of that sequence. The
5 fragments may range in size from ten nucleotides to the entire nucleotide sequence minus one nucleotide (e.g., 10 nucleotides, 20, 30, 40, 50, 100, 200, etc.).

As used herein the term "portion" when in reference to an amino acid sequence (as in "a portion of a given amino acid sequence") refers to fragments of that sequence. The fragments may range in size from six amino acids to the entire amino acid sequence minus
10 one amino acid (e.g., 6 amino acids, 10, 20, 30, 40, 75, 200, etc.).

As used herein, the term "purified" or "to purify" refers to the removal of contaminants from a sample. For example, antigen specific antibodies may be purified by removal of contaminating non-immunoglobulin proteins; they are also purified by the removal of immunoglobulin that does not bind to the same antigen. The removal of non-
15 immunoglobulin proteins and/or the removal of immunoglobulins that do not bind a particular antigen results in an increase in the percent of antigen specific immunoglobulins in the sample. In another example, recombinant antigen specific polypeptides are expressed in bacterial host cells and the polypeptides are purified by the removal of host cell proteins; the percent of recombinant antigen specific polypeptides is thereby increased in the sample.

The term "recombinant DNA molecule" as used herein refers to a DNA molecule that is comprised of segments of DNA joined together by means of molecular biological techniques.
20

The term "recombinant protein" or "recombinant polypeptide" as used herein refers to a protein molecule that is expressed from a recombinant DNA molecule.

The term "native protein" as used herein to indicate that a protein does not contain amino acid residues encoded by vector sequences; that is the native protein contains only those amino acids found in the protein as it commonly occurs in nature. A native protein may be produced by recombinant means or may be isolated from a naturally occurring source.
25

The term "Southern blot," refers to the analysis of DNA on agarose or acrylamide gels to fractionate the DNA according to size followed by transfer of the DNA from the gel to a solid support, such as nitrocellulose or a nylon membrane. The immobilized DNA is then probed with a labeled probe to detect DNA species complementary to the probe used. The DNA may be cleaved with restriction enzymes prior to electrophoresis. Following
30

electrophoresis, the DNA may be partially depurinated and denatured prior to or during transfer to the solid support. Southern blots are a standard tool of molecular biologists (J. Sambrook *et al.*, *Molecular Cloning: A Laboratory Manual*, Cold Spring Harbor Press, NY, pp 9.31-9.58 [1989]).

5 The term "Northern blot," as used herein refers to the analysis of RNA by electrophoresis of RNA on agarose gels to fractionate the RNA according to size followed by transfer of the RNA from the gel to a solid support, such as nitrocellulose or a nylon membrane. The immobilized RNA is then probed with a labeled probe to detect RNA species complementary to the probe used. Northern blots are a standard tool of molecular
10 biologists (J. Sambrook, *et al.*, *supra*, pp 7.39-7.52 [1989]).

 The term "Western blot" refers to the analysis of protein(s) (or polypeptides) immobilized onto a support such as nitrocellulose or a membrane. The proteins are run on acrylamide gels to separate the proteins, followed by transfer of the protein from the gel to a solid support, such as nitrocellulose or a nylon membrane. The immobilized proteins are
15 then exposed to antibodies with reactivity against an antigen of interest. The binding of the antibodies may be detected by various methods, including the use of radiolabelled antibodies.

 The term "antigenic determinant" as used herein refers to that portion of an antigen that makes contact with a particular antibody (*i.e.*, an epitope). When a protein or fragment
20 of a protein is used to immunize a host animal, numerous regions of the protein may induce the production of antibodies that bind specifically to a given region or three-dimensional structure on the protein; these regions or structures are referred to as antigenic determinants. An antigenic determinant may compete with the intact antigen (*i.e.*, the "immunogen" used to elicit the immune response) for binding to an antibody.

25 The term "transgene" as used herein refers to a foreign, heterologous, or autologous gene that is placed into an organism by introducing the gene into newly fertilized eggs or early embryos. The term "foreign gene" refers to any nucleic acid (*e.g.*, gene sequence) that is introduced into the genome of an animal by experimental manipulations and may include gene sequences found in that animal so long as the introduced gene does not reside in the
30 same location as does the naturally-occurring gene. The term "autologous gene" is intended to encompass variants (*e.g.*, polymorphisms or mutants) of the naturally occurring gene. The term transgene thus encompasses the replacement of the naturally occurring gene with a variant form of the gene.

As used herein, the term "vector" is used in reference to nucleic acid molecules that transfer DNA segment(s) from one cell to another. The term "vehicle" is sometimes used interchangeably with "vector."

The term "expression vector" as used herein refers to a recombinant DNA molecule containing a desired coding sequence and appropriate nucleic acid sequences necessary for the expression of the operably linked coding sequence in a particular host organism. Nucleic acid sequences necessary for expression in prokaryotes usually include a promoter, an operator (optional), and a ribosome binding site, often along with other sequences. Eukaryotic cells are known to utilize promoters, enhancers, and termination and polyadenylation signals.

As used herein, the term "host cell" refers to any eukaryotic or prokaryotic cell (e.g., bacterial cells such as *E. coli*, CHO cells, yeast cells, mammalian cells, avian cells, amphibian cells, plant cells, fish cells, and insect cells), whether located *in vitro* or *in vivo*. For example, host cells may be located in a transgenic animal.

The terms "transfection" and "transformation" as used herein refer to the introduction of foreign DNA into cells (e.g. eukaryotic and prokaryotic cells). Transfection may be accomplished by a variety of means known to the art including calcium phosphate-DNA co-precipitation, DEAE-dextran-mediated transfection, polybrene-mediated transfection, electroporation, microinjection, liposome fusion, lipofection, protoplast fusion, retroviral infection, and biolistics.

The term "stable transfection" or "stably transfected" refers to the introduction and integration of foreign DNA into the genome of the transfected cell. The term "stable transfectant" refers to a cell that has stably integrated foreign DNA into the genomic DNA.

The term "transient transfection" or "transiently transfected" refers to the introduction of foreign DNA into a cell where the foreign DNA fails to integrate into the genome of the transfected cell. The foreign DNA persists in the nucleus of the transfected cell for several days. During this time the foreign DNA is subject to the regulatory controls that govern the expression of endogenous genes in the chromosomes. The term "transient transfectant" refers to cells that have taken up foreign DNA but have failed to integrate this DNA.

The term "calcium phosphate co-precipitation" refers to a technique for the introduction of nucleic acids into a cell. The uptake of nucleic acids by cells is enhanced when the nucleic acid is presented as a calcium phosphate-nucleic acid co-precipitate. The original technique of Graham and van der Eb (Graham and van der Eb, *Virology*, 52:456

[1973]), has been modified by several groups to optimize conditions for particular types of cells. The art is well aware of these numerous modifications.

A "composition comprising a given polynucleotide sequence" as used herein refers broadly to any composition containing the given polynucleotide sequence. The composition
5 may comprise an aqueous solution. Compositions comprising polynucleotide sequences encoding, for example, a variant Fc region or fragments thereof may be employed as hybridization probes. In this case, variant Fc region encoding polynucleotide sequences are typically employed in an aqueous solution containing salts (*e.g.*, NaCl), detergents (*e.g.*, SDS), and other components (*e.g.*, Denhardt's solution, dry milk, salmon sperm DNA, etc.).

10 The term "test compound" or "candidate compound" refer to any chemical entity, pharmaceutical, drug, and the like that can be used to treat or prevent a disease, illness, sickness, or disorder of bodily function, or otherwise alter the physiological or cellular status of a sample. Test compounds comprise both known and potential therapeutic compounds. A test compound can be determined to be therapeutic by screening using the
15 screening methods of the present invention. A "known therapeutic compound" refers to a therapeutic compound that has been shown (*e.g.*, through animal trials or prior experience with administration to humans) to be effective in such treatment or prevention.

As used herein, the term "response," when used in reference to an assay, refers to the generation of a detectable signal (*e.g.*, accumulation of reporter protein, increase in ion
20 concentration, accumulation of a detectable chemical product).

As used herein, the term "reporter gene" refers to a gene encoding a protein that may be assayed. Examples of reporter genes include, but are not limited to, luciferase (*See, e.g.*, deWet *et al.*, Mol. Cell. Biol. 7:725 [1987] and U.S. Pat Nos., 6,074,859, incorporated herein by reference), green fluorescent protein (*e.g.*, GenBank Accession Number U43284;
25 a number of GFP variants are commercially available from CLONTECH Laboratories, Palo Alto, CA), chloramphenicol acetyltransferase, β -galactosidase, alkaline phosphatase, and horse radish peroxidase.

As used herein, the terms "computer memory" and "computer memory device" refer to any storage media readable by a computer processor. Examples of computer memory
30 include, but are not limited to, RAM, ROM, computer chips, digital video disc (DVDs), compact discs (CDs), hard disk drives (HDD), and magnetic tape.

As used herein, the term "computer readable medium" refers to any device or system for storing and providing information (*e.g.*, data and instructions) to a computer processor.

Examples of computer readable media include, but are not limited to, DVDs, CDs, hard disk drives, magnetic tape and servers for streaming media over networks.

As used herein, the phrase "computer readable medium encodes a representation" of a nucleic acid or amino acid sequence, refers to computer readable medium that has stored thereon information, that when delivered to a processor, allows the sequence of the nucleic acid or amino acid sequence to be displayed to a user (*e.g.* printed out or presented on a display screen).

As used herein, the terms "processor" and "central processing unit" or "CPU" are used interchangeably and refer to a device that is able to read a program from a computer memory (*e.g.*, ROM or other computer memory) and perform a set of steps according to the program.

As used herein, the numbering of amino acid residues in an immunoglobulin heavy chain uses the EU index format as in Kabat et al., Sequences of Proteins of Immunological Interest, 5th Ed. Public Health Service, National Institutes of Health, Bethesda, MD (1991), expressly incorporated herein by reference. The "EU index format as in Kabat" refers to the residue numbering of the human IgG1 EU antibody.

As used herein a "parent polypeptide" is a polypeptide comprising an amino acid sequence that may be changed or altered (*e.g.* an amino acid substitution, addition or deletion is made) to produce a variant. In preferred embodiments, the parent polypeptide comprises at least a portion of a naturally occurring Fc region or an Fc region with amino acid sequence modifications (*e.g.*, additions, deletions, and/or substitutions). In some embodiments, variants that are shorter or longer than the parent polypeptide are specifically contemplated. In particularly preferred embodiments, the parent polypeptide differs in function (*e.g.* effector function, binding, etc.) as compared to a variant.

As used herein, the term "variant of a parent polypeptide" refers to a peptide comprising an amino acid sequence that differs from that of the parent polypeptide by at least one amino acid modification. In certain embodiments, the variant comprises at least a portion of an Fc region (*e.g.* at least 40%, 50%, 75%, or 90% of an Fc region). In preferred embodiments, the variant comprises an Fc region of a parent polypeptide with at least one amino acid modification.

As used herein, the term "Fc region" refers to a C-terminal region of an immunoglobulin heavy chain (*e.g.*, as shown in Figure 1). The "Fc region" may be a native sequence Fc region or a variant Fc region. Although the generally accepted boundaries of the Fc region of an immunoglobulin heavy chain might vary, the human IgG heavy chain Fc

region is usually defined to stretch from an amino acid residue at position Cys226, or from Pro230, to the carboxyl-terminus thereof. In some embodiments, variants comprise only portions of the Fc region and can include or not include the carboxyl-terminus. The Fc region of an immunoglobulin generally comprises two constant domains, CH2 and CH3, as shown, for example, in Figure 1. In some embodiments, variants having one or more of the constant domains are contemplated. In other embodiments, variants without such constant domains (or with only portions of such constant domains) are contemplated.

As used herein, the "CH2 domain" (also referred to as "C γ 2" domain) generally comprises the stretch of residues that extends from about amino acid 231 to about amino acid 340 in an Fc region (e.g. in the human IgG Fc region). The CH2 domain is unique in that it is not closely paired with another domain. Rather, two N-linked branched carbohydrate chains are interposed between the two CH2 domains of an intact native IgG molecule.

As used herein, the "CH3 domain" generally comprises the stretch of residues C-terminal to a CH2 domain in an Fc region (e.g., from about amino acid residue 341 to about amino acid residue 447 of a human IgG Fc region).

As used herein, an Fc region may possess "effector functions" that are responsible for activating or diminishing a biological activity (e.g. in a subject). Examples of effector functions include, but are not limited to: C1q binding; complement dependent cytotoxicity (CDC); Fc receptor binding; antibody-dependent cell-mediated cytotoxicity (ADCC); phagocytosis; down regulation of cell surface receptors (e.g., B cell receptor; BCR), etc. Such effector functions may require the Fc region to be combined with a binding domain (e.g. an antibody variable domain) and can be assessed using various assays (e.g. Fc binding assay, ACDD assays, CDC assays, etc.).

As used herein the term "native sequence Fc region" refers to an amino acid sequence that is identical to the amino acid sequence of an Fc region commonly found in nature. Exemplary native sequence human Fc regions are shown in Figure 2 and include a native sequence human IgG1 Fc region (non-A and A allotypes); native sequence human IgG2 Fc region; native sequence human IgG3 Fc region; and native sequence human IgG4 Fc region as well as naturally occurring variants thereof. Native sequence murine Fc regions are also shown in Figure 2. Other sequences are contemplated and are readily obtained from various web sites (e.g., NCBI's web site).

As used herein, the term "variant Fc region" refers to amino acid sequence that differs from that of a native sequence Fc region (or portions thereof) by virtue of at least one

amino acid modification (e.g., substitution, insertion, or deletion). In preferred embodiments, the variant Fc region has at least one amino acid substitution compared to a native sequence Fc region (e.g. from about one to about ten amino acid substitutions, and preferably from about one to about five amino acid substitutions in a native sequence Fc region). In preferred embodiments, variant Fc regions will possess at least about 80% homology with a native sequence Fc region, preferably at least about 90% homology, and more preferably at least about 95% homology.

As used herein, the term "homology", when used in reference to amino acid sequences, refers to the percentage of residues in an amino acid sequence variant that are identical with the native amino acid sequence after aligning the sequences and introducing gaps, if necessary, to achieve the maximum percent homology.

The term "Fc region-containing polypeptide" refers to a polypeptide, such as an antibody or immunoadhesin (see definitions below), which comprises an Fc region.

The terms "Fc receptor" and "FcR" are used to describe a receptor that binds to an Fc region (e.g. the Fc region of an antibody or antibody fragment). Portions of Fc receptors are specifically contemplated in some embodiments of the present invention. In preferred embodiments, the FcR is a native sequence human FcR. In other preferred embodiments, the FcR is one which binds an IgG antibody (a gamma receptor) and includes receptors of the Fc γ RI, Fc γ RII, and Fc γ RIII subclasses, including allelic variants and alternatively spliced forms of these receptors. Fc γ RII receptors include Fc γ RIIA (an "activating receptor") and Fc γ RIIB (an "inhibiting receptor"), which have similar amino acid sequences that differ primarily in the cytoplasmic domains thereof. Activating receptor Fc γ RIIA contains an immunoreceptor tyrosine based activation motif (ITAM) in its cytoplasmic domain. Inhibiting receptor Fc γ RIIB contains an immunoreceptor tyrosine-based inhibition motif (ITIM) in its cytoplasmic domain. Other FcRs, including those to be identified in the future, are encompassed by the term "FcR" herein. The term also includes the neonatal receptor, FcRn, which is responsible for the transfer of maternal IgGs to the fetus.

As used herein, the phrase "antibody-dependent cell-mediated cytotoxicity" and "ADCC" refer to a cell-mediated reaction in which cytotoxic cells (e.g. nonspecific) that express FcRs (e.g. Natural Killer (NK) cells, neutrophils, and macrophages) recognize bound antibody on a target cell and subsequently cause lysis of the target cells. The primary cells for mediating ADCC, NK cells, express Fc γ RIII, whereas monocytes express Fc γ RI, Fc γ RII and Fc γ RIII.

As used herein, the phrase "effector cells" refers to leukocytes which express one or more FcRs and perform effector functions. Preferably, the cells express at least FcγRIII and perform an ADCC effector function. Examples of leukocytes which mediate ADCC include peripheral blood mononuclear cells (PBMC), natural killer (NK) cells, monocytes, cytotoxic
5 T cells and neutrophils. The effector cells may be isolated from a native source (e.g. from blood).

As used herein, a polypeptide variant with "altered" FcR binding affinity or ADCC activity is one which has either enhanced (i.e. increased) or diminished (i.e. reduced) FcR binding activity and/or ADCC activity compared to a parent polypeptide or to a polypeptide
10 comprising a native sequence Fc region. A polypeptide variant which "displays increased binding" to an FcR binds at least one FcR with better affinity than the parent polypeptide. A polypeptide variant which "displays decreased binding" to an FcR, binds at least one FcR with worse affinity than a parent polypeptide. Such variants which display decreased binding to an FcR may possess little or no appreciable binding to an FcR, e.g., 0-20%
15 binding to the FcR compared to a parent polypeptide. A polypeptide variant which binds an FcR with "better affinity" than a parent polypeptide, is one which binds any one or more of the above identified FcRs with higher binding affinity than the parent antibody, when the amounts of polypeptide variant and parent polypeptide in a binding assay are essentially the same, and all other conditions are identical. For example, a polypeptide variant with
20 improved FcR binding affinity may display from about 1.10 fold to about 100 fold (more typically from about 1.2 fold to about 50 fold) improvement (i.e. increase) in FcR binding affinity compared to the parent polypeptide, where FcR binding affinity is determined, for example, in an ELISA assay.

As used herein, an "amino acid modification" refers to a change in the amino acid
25 sequence of a given amino acid sequence. Exemplary modifications include, but are not limited to, an amino acid substitution, insertion and/or deletion. In preferred embodiments, the amino acid modification is a substitution (e.g. in an Fc region of a parent polypeptide).

As used herein, an "amino acid modification at" a specified position (e.g. in the Fc region) refers to the substitution or deletion of the specified residue, or the insertion of at
30 least one amino acid residue adjacent the specified residue. By insertion "adjacent" a specified residue is meant insertion within one to two residues thereof. The insertion may be N-terminal or C-terminal to the specified residue.

As used herein, an "amino acid substitution" refers to the replacement of at least one existing amino acid residue in a given amino acid sequence with another different

"replacement" amino acid residue. The replacement residue or residues may be "naturally occurring amino acid residues" (i.e. encoded by the genetic code) and selected from: alanine (Ala); arginine (Arg); asparagine (Asn); aspartic acid (Asp); cysteine (Cys); glutamine (Gln); glutamic acid (Glu); glycine (Gly); histidine (His); isoleucine (Ile); leucine (Leu);
5 lysine (Lys); methionine (Met); phenylalanine (Phe); proline (Pro); serine (Ser); threonine (Thr); tryptophan (Trp); tyrosine (Tyr); and valine (Val). Substitution with one or more non-naturally occurring amino acid residues is also encompassed by the definition of an amino acid substitution herein. A "non-naturally occurring amino acid residue" refers to a residue, other than those naturally occurring amino acid residues listed above, which is able
10 to covalently bind adjacent amino acid residues (s) in a polypeptide chain. Examples of non-naturally occurring amino acid residues include norleucine, ornithine, norvaline, homoserine and other amino acid residue analogues such as those described in Ellman et al. Meth. Enzym. 202: 301-336 (1991), herein incorporated by reference.

As used herein, the term "amino acid insertion" refers to the incorporation of at least
15 one amino acid into a given amino acid sequence. In preferred embodiments, an insertion will usually be the insertion of one or two amino acid residues. In other embodiments, the insertion includes larger peptide insertions (e.g. insertion of about three to about five or even up to about ten amino acid residues).

As used herein, the term "amino acid deletion" refers to the removal of at least one
20 amino acid residue from a given amino acid sequence.

The term "assay signal" refers to the output from any method of detecting protein-protein interactions, including but not limited to, absorbance measurements from colorimetric assays, fluorescent intensity, or disintegrations per minute. Assay formats could include ELISA, facs, or other methods. A change in the "assay signal" may reflect a
25 change in the kinetic off-rate, the kinetic on-rate, or both. A "higher assay signal" refers to the measured output number being larger than another number (e.g. a variant may have a higher (larger) measured number in an ELISA assay as compared to the parent polypeptide). A "lower" assay signal refers to the measured output number being smaller than another number (e.g. a variant may have a lower (smaller) measured number in an ELISA assay as
30 compared to the parent polypeptide).

The term "relative assay signal" refers to the normalized absorbance measurement obtained for an Fc-region variant compared to the parental antibody by setting its value at 1.0 for each receptor. Differences in the relative assay signal may reflect on-rate differences, off-rates differences, or both.

The term "binding affinity" refers to the equilibrium dissociation constant (expressed in units of concentration) associated with each Fc receptor-Fc binding interaction. The binding affinity is directly related to the ratio of the kinetic off-rate (generally reported in units of inverse time, e.g. seconds⁻¹) divided by the kinetic on-rate (generally reported in units of concentration per unit time, e.g. molar /second). In general it is not possible to unequivocally state whether changes in equilibrium dissociation constants are due to differences in on-rates, off-rates or both unless each of these parameters are experimentally determined (e.g., by BIACORE or SAPIDYNE measurements).

The "specificity ratio" is calculated by dividing the normalized FcγRIII assay signal by the normalized FcγRIIb assay signal. A "specificity ratio" of > 1.0 indicates that the variant binds with improved specificity compared to the parental molecule. A specificity ratio of < 1.0 indicates that the variant binds with reduced specificity compared to the parental molecule.

As used herein, the term "relative affinity" when used in reference to the affinity of a polypeptide variant for an Fc receptor is the binding ability of the variant as compared to the parent polypeptide. A relative affinity of 1.0 indicates that the variant is found to bind an Fc receptor to the same extent as the parent polypeptide when both are assayed in identical Fc binding assays (e.g. ELISA). A relative affinity of less than 1.0 means that the variant has lower affinity for the Fc receptor, and a relative affinity of greater than 1.0 indicates that the variant has a higher affinity for the Fc receptor (e.g. more variant binds to a Fc receptor in an ELISA assay).

As used herein, the term "hinge region" refers to the stretch of amino acids in human IgG1 stretching from Glu216 to Pro230 of human IgG1. Hinge regions of other IgG isotypes may be aligned with the IgG1 sequence by placing the first and last cysteine residues forming inter-heavy chain S-S bonds in the same positions.

As used herein, the term "lower hinge region" of an Fc region refers to the stretch of amino acid residues immediately C-terminal to the hinge region (e.g. residues 233 to 239 of the Fc region of IgG1).

"C1q" is a polypeptide that includes a binding site for the Fc region of an immunoglobulin. C1q together with two serine proteases, C1r and C1s, forms the complex C1, the first component of the complement dependent cytotoxicity (CDC) pathway.

As used here, the term "antibody" is used in the broadest sense and specifically covers monoclonal antibodies (including full length monoclonal antibodies), polyclonal

antibodies, multispecific antibodies (e.g., bispecific antibodies), and antibody fragments so long as they exhibit the desired biological activity.

As used herein, the term "antibody fragments" refers to a portion of an intact antibody. Examples of antibody fragments include, but are not limited to, linear antibodies; 5 single-chain antibody molecules; Fc or Fc' peptides, Fab and Fab fragments, and multispecific antibodies formed from antibody fragments. The antibody fragments preferably retain at least part of the hinge and optionally the CH1 region of an IgG heavy chain. In other preferred embodiments, the antibody fragments comprise at least a portion of the CH2 region or the entire CH2 region.

10 As used herein, the term "functional fragment", when used in reference to a monoclonal antibody, is intended to refer to a portion of the monoclonal antibody which still retains a functional activity. A functional activity can be, for example, antigen binding activity or specificity. Monoclonal antibody functional fragments include, for example, individual heavy or light or light chains and fragments thereof, such as VL, VH and Fd; 15 monovalent fragments, such as Fv, Fab, and Fab'; bivalent fragments such as F(ab')₂; single chain Fv (scFv); and Fc fragments. Such terms are described in, for example, Harlowe and Lane, *Antibodies: A Laboratory Manual*, Cold Spring Harbor Laboratory, New York (1989); *Molec. Biology and Biotechnology: A Comprehensive Desk Reference* (Myers, R.A. (ed.), New York: VCH Publisher, Inc.); Huston et al., *Cell Biophysics*, 22:189-224 (1993); Pluckthun and Skerra, *Meth. Enzymol.*, 178:497-515 (1989) and in Day, E.D., 20 *Advanced Immunochemistry*, Second Ed., Wiley-Liss, Inc., New York, NY (1990), all of which are herein incorporated by reference. The term functional fragment is intended to include, for example, fragments produced by protease digestion or reduction of a monoclonal antibody and by recombinant DNA methods known to those skilled in the art.

25 As used herein, "humanized" forms of non-human (e.g., murine) antibodies are chimeric antibodies that contain minimal sequence, or no sequence, derived from non-human immunoglobulin. For the most part, humanized antibodies are human immunoglobulins (recipient antibody) in which residues from a hypervariable region of the recipient are replaced by residues from a hypervariable region of a non-human species 30 (donor antibody) such as mouse, rat, rabbit or nonhuman primate having the desired specificity, affinity, and capacity. In some instances, Fv framework region (FR) residues of the human immunoglobulin are replaced by corresponding non-human residues. Furthermore, humanized antibodies may comprise residues that are not found in the recipient antibody or in the donor antibody. These modifications are generally made to

further refine antibody performance. In general, the humanized antibody will comprise substantially all of at least one, and typically two, variable domains, in which all or substantially all of the hypervariable loops correspond to those of a nonhuman immunoglobulin and all or substantially all of the FR residues are those of a human immunoglobulin sequence. The humanized antibody may also comprise at least a portion of an immunoglobulin constant region (Fc), typically that of a human immunoglobulin. Examples of methods used to generate humanized antibodies are described in U.S. Pat. 5,225,539 to Winter et al. (herein incorporated by reference).

As used herein, the term "hypervariable region" refers to the amino acid residues of an antibody which are responsible for antigen-binding. The hypervariable region comprises amino acid residues from a "complementarity determining region" or "CDR" (i.e. residues 24-34 (L1), 50-56 (L2) and 89-97 (L3) in the light chain variable domain and 31-35 (H1), 50-65 (H2) and 95-102 (H3) in the heavy chain variable domain; Kabat et al., Sequences of Proteins of Immunological Interest, 5th Ed. Public Health Service, National Institutes of Health, Bethesda, MD. (1991)) and/or those residues from a "hypervariable loop" (i.e. residues 26-32 (L1), 50-52 (L2) and 91-96 (L3) in the light chain variable domain and 26-32 (H1), 53-55 (H2) and 96-101 (H3) in the heavy chain variable domain; Chothia and Lesk J. Mol. Biol. 196: 901-917 (1987)). "Framework" or "FR" residues are those variable domain residues other than the hypervariable region residues as defined herein.

As used herein, the term "immunoadhesin" designates antibody-like molecules which combine the binding domain of a heterologous "adhesin" protein (e.g. a receptor, ligand or enzyme) with an immunoglobulin constant domain. Structurally, immunoadhesins comprise a fusion of the adhesin amino acid sequence with the desired binding specificity which is other than the antigen recognition and binding site (antigen combining site) of an antibody (i.e. is "heterologous") with an immunoglobulin constant domain sequence.

As used herein, the term "ligand binding domain" refers to any native receptor or any region or derivative thereof retaining at least a qualitative ligand binding ability of a corresponding native receptor. In certain embodiments, the receptor is from a cell-surface polypeptide having an extracellular domain that is homologous to a member of the immunoglobulin supergenefamily. Other receptors, which are not members of the immunoglobulin supergenefamily but are nonetheless specifically covered by this definition, are receptors for cytokines, and in particular receptors with tyrosine kinase

activity (receptor tyrosine kinases), members of the hematopoietin and nerve growth factor receptor superfamilies, and cell adhesion molecules (e.g. E-, L-, and P- selectins).

As used herein, the term "receptor binding domain" refers to any native ligand for a receptor, including cell adhesion molecules, or any region or derivative of such native
5 ligand retaining at least a qualitative receptor binding ability of a corresponding native ligand.

As used herein, the term "antibody-immunoadhesin chimera" comprises a molecule that combines at least one binding domain of an antibody with at least one immunoadhesin. Examples include, but are not limited to, the bispecific CD4-IgG chimeras described in
10 Berg et al., PNAS (USA) 88:4723-4727 (1991) and Charnow et al., J. Immunol., 153:4268 (1994), both of which are hereby incorporated by reference.

As used herein, an "isolated" polypeptide is one that has been identified and separated and/or recovered from a component of its natural environment. Contaminant components of its natural environment are materials that would interfere with diagnostic or
15 therapeutic uses for the polypeptide, and may include enzymes, hormones, and other proteinaceous or non-proteinaceous solutes. In certain embodiments, the isolated polypeptide is purified (1) to greater than 95% by weight of polypeptides as determined by the Lowry method, and preferably, more than 99% by weight, (2) to a degree sufficient to obtain at least 15 residues of N-terminal or internal amino acid sequence by use of a
20 spinning cup sequenator, or (3) to homogeneity by SDS-page under reducing or nonreducing conditions using Coomassie blue, or silver stain. Isolated polypeptide includes the polypeptide in situ within recombinant cells since at least one component of the polypeptide's natural environment will not be present. Ordinarily, however, isolated polypeptide will be prepared by a least one purification step.

25 As used herein, the term "treatment" refers to both therapeutic treatment and prophylactic or preventative measures. Those in need of treatment include those already with the disorder as well as those in which the disorder is to be prevented.

As used herein, the term "disorder" refers to any condition that would benefit from treatment with a polypeptide variant, including chronic and acute disorders or diseases (e.g.
30 pathological conditions that predispose a patient to a particular disorder. In certain embodiments, the disorder is cancer.

As used herein, the terms "cancer" and "cancerous" refer to or describe the physiological condition in mammals that is typically characterized by unregulated cell growth. Examples of cancer include, but are not limited to, carcinoma, lymphoma,

blastoma, sarcoma, and leukemia. More particular examples of such cancers include squamous cell cancer, small-cell lung cancer, non-small cell lung cancer, adenocarcinoma of the lung, squamous carcinoma of the lung, cancer of the peritoneum, hepatocellular cancer, gastrointestinal cancer, pancreatic cancer, glioblastoma, cervical cancer, ovarian
5 cancer, liver cancer, bladder cancer, hepatoma, breast cancer, colon cancer, colorectal cancer, endometrial or uterine carcinoma, salivary gland carcinoma, kidney cancer, liver cancer, prostate cancer, vulval cancer, thyroid cancer, hepatic carcinoma and various types of head and neck cancer.

As used herein, the phrase "HER2-expressing cancer" is one comprising cells which
10 have HER2 receptor protein (e.g., Genebank accession number X03363) present at their cell surface, such that an anti-HER2 antibody is able to bind to the cancer.

As used herein, the term "label" refers to a detectable compound or composition which is conjugated directly or indirectly to a polypeptide. The label may itself be detectable (e.g., radioisotope labels or fluorescent labels) or, in the case of an enzymatic
15 label, may catalyze chemical alteration of a substrate compound or composition which is detectable.

As used herein, the terms "control element", "control sequence" and "regulatory element" refers to a genetic element that controls some aspect of the expression of nucleic acid sequences. For example, a promoter is a regulatory element that facilitates the
20 initiation of transcription of an operably linked coding region. Other regulatory elements include splicing signals, polyadenylation signals, termination signals, etc. Control elements that are suitable for prokaryotes, for example, include a promoter, optionally an operator sequence, and a ribosome binding site. Eukaryotic cells are known to utilize promoters, polyadenylation signals, and enhancers.

As used herein, nucleic acid is "operably linked" when it is placed into a functional
25 relationship with another nucleic acid sequence. For example, DNA for a presequence or secretory leader is operably linked to DNA for a polypeptide if it is expressed as a preprotein that participates in the secretion of the polypeptide; a promoter or enhancer is operably linked to a coding sequence if it affects the transcription of the sequence; or a
30 ribosome binding site is operably linked to a coding sequence if it is positioned so as to facilitate translation. In preferred embodiments, "operably linked" means that the DNA sequences being linked are contiguous, and, in the case of a secretory leader, contiguous and in reading frame. However enhancers, for example, do not have to be contiguous. Linking may be accomplished, for example, by ligation at convenient restriction sites. If such sites

do not exist, synthetic oligonucleotide adaptors or linkers may be used in accordance with conventional practice.

As used herein, the expressions "cell," "cell line," and "cell culture" are used interchangeably and all such designations include progeny. Thus, the words
5 "transformants" and "transformed cells" include the primary subject cell and cultures derived therefrom without regard for the number of transfers. It is also understood that all progeny may not be precisely identical in DNA content due to deliberate or inadvertent mutations. Mutant progeny that have the same function or biological activity as screened for in the originally transformed cell are included. Where distinct designations are intended,
10 it will be clear from the context.

As used herein, "analyte" refers to a substance that is to be analyzed. The preferred analyte is an Fc region containing polypeptide that is to be analyzed for its ability to bind to an Fc receptor.

As used herein, the term "receptor" refers to a polypeptide capable of binding at
15 least one ligand. The preferred receptor is a cell-surface or soluble receptor having an extracellular ligand-binding domain and, optionally, other domains (e.g. transmembrane domain, intracellular domain and/or membrane anchor). A receptor to be evaluated in an assay described herein may be an intact receptor or a fragment or derivative thereof (e.g. a fusion protein comprising the binding domain of the receptor fused to one or more
20 heterologous polypeptides). Moreover, the receptor to be evaluated for its binding properties may be present in a cell or isolated and optionally coated on an assay plate or some other solid phase or labeled directly and used as a probe.

As used herein, the phrase "CHO-expressed polypeptide" refers to a polypeptide that has been recombinantly expressed in Chinese Hamster Ovary (CHO) cells.

25 As used herein, the term "antibody responsive disease" refers to any disease or medical condition that is shown to be treatable, at least in part, with antibody therapy. Examples of such diseases and medical conditions include, but are not limited to, lymphoma (shown to be treatable with RITUXAN), infectious disease (shown to be treatable with SYNAGIS), kidney transplant (ZENAPAX has shown to be helpful), Crohn's disease and
30 rheumatoid arthritis (shown to be treatable with REMICADE), breast carcinoma (shown to be treatable with HERCEPTIN), and colon cancer (shown to be treatable with EDRECOLOMAB). As used herein, the term "immunoadhesin responsive disease" refers to any disease or medical condition that is shown to be treatable, at least in part, with immunoadhesin therapy.

As used herein a polypeptide variant that "mediates antibody-dependent cell-mediated cytotoxicity (ADCC) in the presence of human effector cells more effectively" than a parent antibody is one which in vitro or in vivo is substantially more effective at mediating ADCC, when the amounts of polypeptide variant and parent antibody used in the
5 assay are essentially the same. For example, such a variant causes a higher amount of target cell lysis in a given ADCC assay than the parent polypeptide in an identical ADCC assay. Such variants may be identified, for example, using an ADCC assay, but other assays or methods for determining ADCC activity may also be employed (e.g. animal models). In preferred embodiments, the polypeptide variant is from about 1.5 fold, 50 fold, 100 fold,
10 about 500 fold, or about 1000 fold more effective at mediating ADCC than the parent polypeptide.

The term "symptoms of an antibody or immunoadhesin responsive disease" refers to those symptoms generally associated with a particular disease. For example, the symptoms normally associated with Crohn's disease include: abdominal pain, diarrhea, rectal bleeding,
15 weight loss, fever, loss of appetite, dehydration, anemia, distention, fibrosis, inflamed intestines and malnutrition.

The phrase "under conditions such that the symptoms are reduced" refers to any degree of qualitative or quantitative reduction in detectable symptoms of any antibody or immunoadhesin responsive disease, including but not limited to, a detectable impact on the
20 rate of recovery from disease (e.g. rate of weight gain), or the reduction of at least one of the symptoms normally associated with the particular disease (e.g., if the antibody or immunoadhesin responsive disease were Crohn's disease, a reduction in at least one of the following symptoms: abdominal pain, diarrhea, rectal bleeding, weight loss, fever, loss of
appetite, dehydration, anemia, distention, fibrosis, inflamed intestines and malnutrition).

25

DESCRIPTION OF THE INVENTION

The present invention provides polypeptide Fc region variants and oligonucleotides encoding Fc region variants. Specifically, the present invention provides compositions comprising novel Fc region variants, methods for identifying useful Fc region variants, and
30 methods for employing Fc region variants for treating disease. The description of the invention is provided below in the following sections: I.) Antibody Fc Regions; II.) Variant Fc Regions; III.) Combination Variants; IV.) Variant Fc Region Assays; V.) Exemplary Variant Fc Region Containing Molecules; VI.) Nucleic Sequences Encoding Fc Region

Variants; VII.) Therapeutic Uses and Formulations; VIII.) Additional Variant Fc Region Uses.

I. Antibody Fc Regions

5 As described above, antibodies have regions, primarily the CH2 and CH3 regions, that are involved in non-antigen binding functions. Together, these regions are generally known as the Fc region, and have several effector functions mediated by binding of effector molecules.

The effector functions mediated by the antibody Fc region can be divided into two
10 categories: (1) effector functions that operate after the binding of antibody to an antigen (these functions involve, for example, the participation of the complement cascade or Fc receptor (FcR)-bearing cells); and (2) effector functions that operate independently of antigen binding (these functions confer, for example, persistence in the circulation and the ability to be transferred across cellular barriers by transcytosis). For example, binding of
15 the C1 component of complement to antibodies activates the complement system. Activation of complement is important in the opsonisation and lysis of cell pathogens. The activation of complement also stimulates the inflammatory response and may also be involved in autoimmune hypersensitivity. Further, antibodies bind to cells via the Fc region, with an Fc receptor binding site on the antibody Fc region binding to a Fc receptor
20 (FcR) on a cell. There are a number of Fc receptors which are specific for different classes of antibody, including IgG (gamma receptors), IgE (eta receptors), IgA (alpha receptors) and IgM (mu receptors). While the present invention is not limited to any particular mechanism, binding of antibody to Fc receptors on cell surfaces triggers a number of important and diverse biological responses including engulfment and destruction of
25 antibody-coated particles, clearance of immune complexes, lysis of antibody-coated target cells by killer cells (called antibody-dependent cell-mediated cytotoxicity, or ADCC), release of inflammatory mediators, placental transfer and control of immunoglobulin production.

Several antibody effector functions are mediated by Fc receptors (FcRs), which bind
30 the Fc region of an antibody. FcRs are defined by their specificity for immunoglobulin isotypes; Fc receptors for IgG antibodies are referred to as Fc γ R, for IgE as Fc ϵ R, for IgA as Fc α R and so on. Three subclasses of Fc γ R have been identified: Fc γ RI (CD64), Fc γ RII (CD32) and Fc γ RIII (CD16).

Because each Fc γ R subclass is encoded by two or three genes, and alternative RNA splicing leads to multiple transcripts, a broad diversity in Fc γ R isoforms exists. The three genes encoding the Fc γ R1 subclass (Fc γ RIA, Fc γ RIB and Fc γ RIC) are clustered in region 1q21.1 of the long arm of chromosome 1; the genes encoding Fc γ RII isoforms (Fc γ RIIA, Fc γ RIIB and Fc γ RIIC) and the two genes encoding Fc γ RIII (Fc γ RIIIA and Fc γ RIIIB) are all clustered in region 1q22. These different FcR subtypes are expressed on different cell types (see, e.g., Ravetch and Kinet, *Annu. Rev. Immunol.* 9: 457-492 (1991)). For example, in humans, Fc γ RIIIB is found only on neutrophils, whereas Fc γ RIIIA is found on macrophages, monocytes, natural killer (NK) cells, and a subpopulation of T-cells. Notably, Fc γ RIIIA is the only FcR present on NK cells, one of the cell types implicated in ADCC.

Fc γ RI, Fc γ RII and Fc γ RIII are immunoglobulin superfamily (IgSF) receptors; Fc γ RI has three IgSF domains in its extracellular domain, while Fc γ RII and Fc γ RIII have only two IgSF domains in their extracellular domains.

Another type of Fc receptor is the neonatal Fc receptor (FcRn). FcRn is structurally similar to major histocompatibility complex (MHC) and consists of an α -chain noncovalently bound to β 2-microglobulin.

II. Variant Fc Regions

The present invention provides polypeptide variants, nucleic acid sequences encoding the polypeptide variants, and methods for generating polypeptide variants. Preferably, the polypeptide variants of the present invention differ from a parent polypeptide by at least one amino acid modification. The "parent", "starting" or "nonvariant" polypeptide preferably comprises at least a portion of an antibody Fc region, and may be prepared using techniques available in the art for generating polypeptides comprising an Fc region or portion thereof. In preferred embodiments, the parent polypeptide is an antibody. The parent polypeptide may, however, be any other polypeptide comprising at least a portion of an Fc region (e.g. an immunoadhesin). In certain embodiments, a variant Fc region may be generated (e.g. according to the methods disclosed herein) and can be fused to a heterologous polypeptide of choice, such as an antibody variable domain or binding domain of a receptor or ligand.

In preferred embodiments, the parent polypeptide comprises an Fc region or functional portion thereof. Generally the Fc region of the parent polypeptide will comprise a native sequence Fc region, and preferably a human native sequence Fc region. However,

the Fc region of the parent polypeptide may have one or more pre-existing amino acid sequence alterations or modifications from a native sequence Fc region. For example, the C1q binding activity of the Fc region may have been previously altered or the FcγR binding affinity of the Fc region may have been altered. In further embodiments, the parent

5 polypeptide Fc region is conceptual (e.g. mental thought or a visual representation on a computer or on paper) and, while it does not physically exist, the antibody engineer may decide upon a desired variant Fc region amino acid sequence and generate a polypeptide comprising that sequence or a DNA encoding the desired variant Fc region amino acid sequence. However, in preferred embodiments, a nucleic acid encoding an Fc region of a

10 parent polypeptide is available (e.g. commercially) and this nucleic acid sequence is altered to generate a variant nucleic acid sequence encoding the Fc region variant.

Nucleic acid encoding a variant of the parent polypeptide may be prepared by methods known in the art using the guidance of the present specification for particular sequences. These methods include, but are not limited to, preparation by site-directed (or

15 oligonucleotide-mediated) mutagenesis, PCR mutagenesis, and cassette mutagenesis of an earlier prepared nucleic acid encoding the polypeptide. Site-directed mutagenesis is a preferred method for preparing substitution variants. This technique is well known in the art (see, e.g., Carter et al. *Nucleic Acids Res.* 13: 4431-4443 (1985) and Kunkel et. al., *Proc. Natl. Acad. Sci. USA* 82: 488 (1987), both of which are hereby incorporated by reference).

20 Briefly, in carrying out site directed mutagenesis of DNA, the starting DNA is altered by first hybridizing an oligonucleotide encoding the desired mutation to a single strand of such starting DNA. After hybridization, a DNA polymerase is used to synthesize an entire second strand, using the hybridized oligonucleotide as a primer, and using the single strand of the starting DNA as a template. Thus, the oligonucleotide encoding the desired mutation

25 is incorporated in the resulting double-stranded DNA.

PCR mutagenesis is also suitable for making amino acid sequence variants of the starting polypeptide (see, e.g., Vallette et. al., *Nuc. Acids Res.* 17: 723-733 (1989), hereby incorporated by reference). Briefly, when small amounts of template DNA are used as starting material in a PCR, primers that differ slightly in sequence from the corresponding

30 region in a template DNA can be used to generate relatively large quantities of a specific DNA fragment that differs from the template sequence only at the positions where the primers differ from the template.

Another method for preparing variants, cassette mutagenesis, is based on the technique described by Wells et al., *Gene* 34: 315-323 (1985), hereby incorporated by

reference. The starting material is the plasmid (or other vector) comprising the starting polypeptide DNA to be mutated. The codon(s) in the starting DNA to be mutated are identified. There must be a unique restriction endonuclease site on each side of the identified mutation site(s). If no such restriction sites exist, they may be generated using the
5 above-described oligonucleotide-mediated mutagenesis method to introduce them at appropriate locations in the starting polypeptide DNA. The plasmid DNA is cut at these sites to linearize it. A double-stranded oligonucleotide encoding the sequence of the DNA between the restriction sites but containing the desired mutation(s) is synthesized using standard procedures, wherein the two strands of the oligonucleotide are synthesized
10 separately and then hybridized together using standard techniques. This double-stranded oligonucleotide is referred to as the cassette. This cassette is designed to have 5' and 3' ends that are compatible with the ends of the linearized plasmid, such that it can be directly ligated to the plasmid. This plasmid now contains the mutated DNA sequence.

Alternatively, or additionally, the desired amino acid sequence encoding a
15 polypeptide variant can be determined, and a nucleic acid sequence encoding such amino acid sequence variant can be generated synthetically.

The amino acid sequence of the parent polypeptide may be modified in order to generate a variant Fc region with altered Fc receptor binding affinity or activity in vitro and/or in vivo and/or altered antibody-dependent cell-mediated cytotoxicity (ADCC)
20 activity in vitro and/or in vivo. The amino acid sequence of the parent polypeptide may also be modified in order to generate a variant Fc region with altered complement binding properties and/or circulation half-life.

Substantial modifications in the biological properties of the Fc region may be accomplished by selecting substitutions that differ significantly in their effect on
25 maintaining (a) the structure of the polypeptide backbone in the area of the substitution, for example, as a sheet or helical conformation, (b) the charge or hydrophobicity of the molecule at the target site, or (c) the bulk of the side chain. Naturally occurring residues are divided into classes based on common side-chain properties:

- (1) hydrophobic: norleucine, met, ala, val, leu, ile;
- 30 (2) neutral hydrophilic: cys, ser, thr;
- (3) acidic: asp, glu;
- (4) basic: asn, gln, his, lys, arg;
- (5) residues that influence chain orientation: gly, pro; and
- (6) aromatic: trp, tyr, phe.

Non-conservative substitutions will entail exchanging a member of one of these classes for a member of another class. Conservative substitutions will entail exchanging a member of one of these classes for another member of the same class.

As is demonstrated in the Examples below, one can engineer an Fc region variant
5 with altered binding affinity for one or more FcRs. One may, for example, modify one or more amino acid residues of the Fc region in order to alter (e.g. increase or decrease) binding to an FcR. In preferred embodiments, a modification comprises one or more of the Fc region residues identified herein (See, e.g, Example 2, and WO0042072, herein incorporated by reference for all purposes). Generally, one will make an amino acid
10 substitution at one or more of the Fc region residues identified herein as effecting FcR binding in order to generate such an Fc region variant. In preferred embodiments, no more than one to about ten Fc region residues will be deleted or substituted. The Fc regions herein comprising one or more amino acid modifications (e.g. substitutions) will preferably retain at least about 80%, and preferably at least about 90%, and most preferably at least
15 about 95%, of the parent Fc region sequence or of a native sequence human Fc region.

One may also make amino acid insertion Fc region variants, which variants have altered effector function. For example, one may introduce at least one amino acid residue (e.g. one to two amino acid residues and generally no more than ten residues) adjacent to one or more of the Fc region positions identified herein as impacting FcR binding. By
20 "adjacent" is meant within one to two amino acid residues of a Fc region residue identified herein. Such Fc region variants may display enhanced or diminished FcR binding and/or ADCC activity. In order to generate such insertion variants, one may evaluate a co-crystal structure of a polypeptide comprising a binding region of an FcR (e.g. the extracellular domain of the FcR of interest) and the Fc region into which the amino acid residue(s) are to
25 be inserted (see, e.g., Sondermann et al. Nature 406:267 (2000); Deisenhofer, Biochemistry 20 (9): 2361-2370 (1981); and Burmeister et al., Nature 342: 379-383, (1994), all of which are herein incorporated by reference) in order to rationally design an Fc region variant with, e.g., improved FcR binding ability. In preferred embodiments, such insertion(s) are made in an Fc region loop, but not in the secondary structure (i.e. in a β -strand) of the Fc region.

30 By introducing the appropriate amino acid sequence modifications in a parent Fc region, one can generate a variant Fc region which (a) mediates antibody-dependent cell-mediated cytotoxicity (ADCC) in the presence of human effector cells more or less effectively and/or (b) binds an Fc gamma receptor (Fc γ R) or Fc neonatal receptor (FcRn)

with better affinity than the parent polypeptide. Such Fc region variants will generally comprise at least one amino acid modification in the Fc region.

In preferred embodiments, the parent polypeptide Fc region is a human Fc region, e.g. a native human Fc region human IgG1 (A and non-A allotypes), IgG2, IgG3, IgG4, and all allotypes known or discovered from any species. Fc region. Such regions have sequences such as those shown in Figure 2 (SEQ ID NO:15-22).

In certain embodiments, in order to generate an Fc region with improved ADCC activity, the parent polypeptide preferably has pre-existing ADCC activity (e.g., the parent polypeptide comprises a human IgG1 or human IgG3 Fc region). In some embodiments, a variant with improved ADCC mediates ADCC substantially more effectively than an antibody with a native sequence IgG1 or IgG3 Fc region (e.g. D280H and K290S variants).

In preferred embodiments, amino acid modification(s) are introduced into the CH2 domain of a Fc region. Useful amino acid positions for modification in order to generate a variant IgG Fc region with altered Fc gamma receptor (FcγR) binding affinity or activity include any one or more of amino acid positions: 268, 269, 270, 272, 276, 278, 280, 283, 285, 286, 289, 290, 292, 293, 294, 295, 296, 298, 300, 301, 303, 305, 307, 309, 331, 333, 334, 335, 337, 338, 340, 360, 373, 376, 416, 419, 430, 434, 435, 437, 438 or 439 of the Fc region. In preferred embodiments, the parent Fc region used as the template to generate such variants comprises a human IgG Fc region. In some embodiments, to generate an Fc region variant with reduced binding to the FcγR one may introduce an amino acid modification at any one or more of amino acid positions: 252, 254, 265, 268, 269, 270, 272, 278, 289, 292, 293, 294, 295, 296, 298, 300, 301, 303, 322, 324, 327, 329, 333, 335, 338, 340, 373, 376, 382, 388, 389, 414, 416, 419, 434, 435, 437, 438 or 439 of the Fc region. In particular embodiments, variants with improved binding to one or more FcγRs may also be made. Such Fc region variants may comprise an amino acid modification at any one or more of amino acid positions: 280, 283, 285, 286, 290, 294, 295, 298, 300, 301, 305, 307, 309, 312, 315, 331, 333, 334, 337, 340, 360, 378, 398 or 430 of the Fc region.

In certain embodiments, the present invention provides compositions comprising a variant of a parent polypeptide having an Fc region, wherein the variant binds an Fc gamma receptor (FcγR) with higher affinity than said parent polypeptide, and/or interacts with an FcγR with a higher assay signal, and/or mediates antibody-dependent cell-mediated cytotoxicity (ADCC) in the presence of effector cells, and comprises at least one amino acid modification at position 300 in the Fc region. In certain embodiments, the amino acid modification is Y300I. In other embodiments, the amino acid modification is Y300L.

In some embodiments, the present invention provides compositions comprising a variant of a parent polypeptide having an Fc region, wherein the variant binds an Fc gamma receptor III (FcγRIII) with higher affinity, or the variant interacts with an FcγRIII with a higher assay signal, than the parent polypeptide, and/or mediates antibody-dependent cell-mediated cytotoxicity (ADCC) in the presence of effector cells, and comprises at least one amino acid modification at position 295 in the Fc region. In certain embodiments, the amino acid modification is Q295K or Q295L.

In particular embodiments, the present invention provides compositions comprising a variant of a parent polypeptide having an Fc region, wherein the variant binds an Fc gamma receptor III (FcγRIII) with higher affinity, or the variant interacts with an FcγRIII with a higher assay signal, than the parent polypeptide, and/or mediates antibody-dependent cell-mediated cytotoxicity (ADCC) in the presence of effector cells, and comprises at least one amino acid modification at position 294 in the Fc region. In certain embodiments, the amino acid modification is E294N.

In other embodiments, the present invention provides compositions comprising a variant of a parent polypeptide having an Fc region, wherein the variant has a binding affinity, or assay signal, for FcγRII or FcγRIIb that is approximately 0.25 or less as measured in an ELISA FcγR binding assay. In certain embodiments, the variant comprises at least one amino acid modification at position 296 in the Fc region. In particular embodiments, the at least one amino acid modification at position 296 is Y296P. In other embodiments, the variant comprises at least one amino acid modification at position 298 in the Fc region. In some embodiments, the at least one amino acid modification at position 298 is S298P.

In particular embodiments, the present invention provides compositions comprising a variant of a parent polypeptide having an Fc region, wherein the variant binds an FcγRIII with greater affinity, and FcγRIIb with less affinity, than the parent polypeptide and the variant comprises a S298N amino acid modification in the Fc region. In some embodiments, the present invention provides compositions comprising a variant of a parent polypeptide having an Fc region, wherein the variant interacts with an FcγRIII with a higher assay signal, and FcγRIIb with lower assay signal, than the parent polypeptide and the variant comprises a S298N amino acid modification in the Fc region.

In other embodiments, the present invention provides compositions comprising a variant of a parent polypeptide having an Fc region, wherein the variant binds an FcγRIII with greater affinity, and FcγRIIb with less affinity, than the parent polypeptide and the

variant comprises a S298V amino acid modification in the Fc region. In some embodiments, the present invention provides compositions comprising a variant of a parent polypeptide having an Fc region, wherein the variant interacts with an Fc γ RIII with a higher assay signal, and Fc γ RIIb with a lower assay signal, than the parent polypeptide and the
5 variant comprises a S298V amino acid modification in the Fc region.

In some embodiments, the present invention provides compositions comprising a variant of a parent polypeptide having an Fc region, wherein the variant binds an Fc γ RIII with greater affinity, and Fc γ RIIb with less affinity, than the parent polypeptide and the variant comprises a S298D amino acid modification in the Fc region. In other

10 embodiments, the present invention provides compositions comprising a variant of a parent polypeptide having an Fc region, wherein the variant interacts with an Fc γ RIII with a higher assay signal, and Fc γ RIIb with a lower assay signal, than the parent polypeptide and the variant comprises a S298D amino acid modification in the Fc region.

In certain embodiments, the present invention provides compositions comprising a
15 variant of a parent polypeptide having an Fc region, wherein the variant has a binding affinity, or assay signal, for Fc γ RII or Fc γ RIIb that is approximately 0.25 or less as measured in an ELISA Fc γ R binding assay, and wherein the variant comprises at least one amino acid modification at position 298 of the Fc region. In particular embodiments, the amino acid modification at position 298 is S298P.

20 The polypeptide variants described above may be subjected to further modifications, depending on the desired or intended use of the polypeptide. Such modifications may involve, for example, further alteration of the amino acid sequence (substitution, insertion and/or deletion of amino acid residues), fusion to heterologous polypeptide(s) and/or covalent modifications. Such further modifications may be made prior to, simultaneously
25 with, or following, the amino acid modification(s) disclosed above which result in an alteration of Fc receptor binding and/or ADCC activity.

Alternatively or additionally, it may be useful to combine amino acid modifications with one or more further amino acid modifications that alter C1q binding and/or complement dependent cytotoxicity function of the Fc region. The starting polypeptide of
30 particular interest herein is one that binds to C1q and displays complement dependent cytotoxicity (CDC). Amino acid substitutions described herein may serve to alter the ability of the starting polypeptide to bind to C1q and/or modify its complement dependent cytotoxicity function (e.g. to reduce and preferably abolish these effector functions). However, polypeptides comprising substitutions at one or more of the described positions

with improved C1q binding and/or complement dependent cytotoxicity (CDC) function are contemplated herein. For example, the starting polypeptide may be unable to bind C1q and/or mediate CDC and may be modified according to the teachings herein such that it acquires these further effector functions. Moreover, polypeptides with pre-existing C1q
5 binding activity, optionally further having the ability to mediate CDC may be modified such that one or both of these activities are enhanced. Amino acid modifications that alter C1q and/or modify its complement dependent cytotoxicity function are described, for example, in WO0042072, which is hereby incorporated by reference.

As disclosed above, one can design an Fc region or portion thereof with altered
10 effector function, e.g., by modifying C1q binding and/or FcR binding and thereby changing CDC activity and/or ADCC activity. For example, one can generate a variant Fc region with improved C1q binding and improved FcγRIII binding (e.g. having both improved ADCC activity and improved CDC activity). Alternatively, where one desires that effector function be reduced or ablated, one may engineer a variant Fc region with reduced CDC
15 activity and/or reduced ADCC activity. In other embodiments, one may increase only one of these activities, and optionally also reduce the other activity, e.g. to generate an Fc region variant with improved ADCC activity, but reduced CDC activity and vice versa.

Another type of amino acid substitution serves to alter the glycosylation pattern of the polypeptide. This may be achieved, for example, by deleting one or more carbohydrate
20 moieties found in the polypeptide, and/or adding one or more glycosylation sites that are not present in the polypeptide. Glycosylation of polypeptides is typically either N-linked or O-linked. N-linked refers to the attachment of the carbohydrate moiety to the side chain of an asparagine residue. The peptide sequences asparagine-X-serine and asparagine-X-threonine, where X is any amino acid except proline, are the recognition sequences for
25 enzymatic attachment of the carbohydrate moiety to the asparagine side chain. Thus, the presence of either of these peptide sequences in a polypeptide creates a potential glycosylation site. O-linked glycosylation refers to the attachment of one of the sugars N-acetylgalactosamine, galactose, or xylose to a hydroxyamino acid, most commonly serine or threonine, although 5-hydroxyproline or 5-hydroxylysine may also be used.

30 Addition of glycosylation sites to the polypeptide is conveniently accomplished by altering the amino acid sequence such that it contains one or more of the above-described tripeptide sequences (for N-linked glycosylation sites). The alteration may also be made by the addition of, or substitution by, one or more serine or threonine residues to the sequence

of the original polypeptide (for O-linked glycosylation sites). An exemplary glycosylation variant has an amino acid substitution of residue Asn 297 of the heavy chain.

In some embodiments, the present invention provides compositions comprising a variant of a parent polypeptide having an Fc region, wherein the variant comprises at least
5 one surface residue amino acid modification (See, e.g., Deisenhofer, *Biochemistry*,
28;20(9):2361-70, April 1981, and WO0042072, both of which are hereby incorporated by
reference). In other embodiments, the present invention provides compositions comprising
a variant of a parent polypeptide having an Fc region, wherein the variant comprises at least
one non-surface residue amino acid modification. In further embodiments, the present
10 invention comprises a variant of a parent polypeptide having an Fc region, wherein the
variant comprises at least one surface amino acid modification and at least one non-surface
amino acid modification.

15

III. Combination Variants

In some embodiments, the variants of the present comprise two or more amino acid
modifications (e.g. substitutions). Such combination variants may be produced, for
20 example, by selecting two or more of the amino acid modifications detailed above. Tables 1
and 2 below provide exemplary combinations of two or more amino acid substitutions. For
example, the first row of Table 1 shows possible combinations of Y300I with other amino
acid substitutions at positions 298, 296, 295, and 294 (e.g. this row shows combinations of
two, three, four and five amino acid modifications).

25

TABLE 1
Exemplary Combination Variants

Starting Variant	Position 300	Position 298	Position 296	Position 295	Position 294
Y300I +	-----	S298N, S298V, S298D, S298P, S298A, S298G, S298T, or S298L.	Y296P, Y296F, or N276Q.	Q295K, Q295L, or Q295A.	E294N, E294A, E294Q, or E294D.
Y300L +	-----	S298N, S298V, S298D, S298P, S298A, S298G, S298T, or S298L.	Y296P, Y296F, or N276Q.	Q295K, Q295L, or Q295A.	E294N, E294A, E294Q, or E294D.
S298N +	Y300I, Y300L, or Y300F.	-----	Y296P, Y296F, or N276Q.	Q295K, Q295L, or Q295A.	E294N, E294A, E294Q, or E294D.
S298V +	Y300I, Y300L, or Y300F.	-----	Y296P, Y296F, or N276Q.	Q295K, Q295L, or Q295A.	E294N, E294A, E294Q, or E294D.
S298D +	Y300I, Y300L, or Y300F.	-----	Y296P, Y296F, or N276Q.	Q295K, Q295L, or Q295A.	E294N, E294A, E294Q, or E294D.
S298P +	Y300I, Y300L, or Y300F.	-----	Y296P, Y296F, or N276Q.	Q295K, Q295L, or Q295A.	E294N, E294A, E294Q, or E294D.
Y296P +	Y300I, Y300L, or Y300F.	S298N, S298V, S298D, S298P, S298A, S298G, S298T, or S298L.	-----	Q295K, Q295L, or Q295A.	E294N, E294A, E294Q, or E294D.
Q295K +	Y300I, Y300L, or Y300F.	S298N, S298V, S298D, S298P, S298A, S298G, S298T, or S298L.	Y296P, Y296F, or N276Q.	-----	E294N, E294A, E294Q, or E294D.
Q295L +	Y300I, Y300L, or Y300F.	S298N, S298V, S298D, S298P, S298A, S298G, S298T, or S298L.	Y296P, Y296F, or N276Q.	-----	E294N, E294A, E294Q, or E294D.
E294N +	Y300I, Y300L, or Y300F.	S298N, S298V, S298D, S298P, S298A, S298G, S298T, or S298L.	Y296P, Y296F, or N276Q.	Q295K, Q295L, or Q295A.	-----

** Note that table uses EU numbering as in Kabat.

TABLE 2
Exemplary Combination Variants

Starting Variant	Position 334	Position 333	Position 324	Position 286	Position 276
Y300I +	K334A, K334R, K334Q, K334N, K334S, K334E, K334D, K334M, K334Y, K334W, K334H, K334V, or K334L.	E33A, E333Q, E333N, E333S, E333K, E333R, E333D, or E333G.	S324A, S324N, S324Q, S324K, or S324E.	N286Q, N286S, N286A, or N286D.	N276Q, N276A, or N276K.
Y300L +	K334A, K334R, K334Q, K334N, K334S, K334E, K334D, K334M, K334Y, K334W, K334H, K334V, or K334L.	E33A, E333Q, E333N, E333S, E333K, E333R, E333D, or E333G.	S324A, S324N, S324Q, S324K, or S324E.	N286Q, N286S, N286A, or N286D.	N276Q, N276A, or N276K.
S298N +	K334A, K334R, K334Q, K334N, K334S, K334E, K334D, K334M, K334Y, K334W, K334H, K334V, or K334L.	E33A, E333Q, E333N, E333S, E333K, E333R, E333D, or E333G.	S324A, S324N, S324Q, S324K, or S324E.	N286Q, N286S, N286A, or N286D.	N276Q, N276A, or N276K.
S298V +	K334A, K334R, K334Q, K334N, K334S, K334E, K334D, K334M, K334Y, K334W, K334H, K334V, or K334L.	E33A, E333Q, E333N, E333S, E333K, E333R, E333D, or E333G.	S324A, S324N, S324Q, S324K, or S324E.	N286Q, N286S, N286A, or N286D.	N276Q, N276A, or N276K.
S298D +	K334A, K334R, K334Q, K334N, K334S, K334E, K334D, K334M, K334Y, K334W, K334H, K334V, or K334L.	E33A, E333Q, E333N, E333S, E333K, E333R, E333D, or E333G.	S324A, S324N, S324Q, S324K, or S324E.	N286Q, N286S, N286A, or N286D.	N276Q, N276A, or N276K.
S298P +	K334A, K334R, K334Q, K334N, K334S, K334E, K334D, K334M, K334Y, K334W, K334H, K334V, or K334L.	E33A, E333Q, E333N, E333S, E333K, E333R, E333D, or E333G.	S324A, S324N, S324Q, S324K, or S324E.	N286Q, N286S, N286A, or N286D.	N276Q, N276A, or N276K.
Y296P +	K334A, K334R, K334Q, K334N, K334S, K334E, K334D, K334M, K334Y, K334W, K334H, K334V, or K334L.	E33A, E333Q, E333N, E333S, E333K, E333R, E333D, or E333G.	S324A, S324N, S324Q, S324K, or S324E.	N286Q, N286S, N286A, or N286D.	N276Q, N276A, or N276K.
Q295K +	K334A, K334R, K334Q, K334N, K334S, K334E, K334D, K334M, K334Y, K334W, K334H, K334V, or K334L.	E33A, E333Q, E333N, E333S, E333K, E333R, E333D, or E333G.	S324A, S324N, S324Q, S324K, or S324E.	N286Q, N286S, N286A, or N286D.	N276Q, N276A, or N276K.
Q295L +	K334A, K334R, K334Q, K334N, K334S, K334E, K334D, K334M, K334Y, K334W, K334H, K334V, or K334L.	E33A, E333Q, E333N, E333S, E333K, E333R, E333D, or E333G.	S324A, S324N, S324Q, S324K, or S324E.	N286Q, N286S, N286A, or N286D.	N276Q, N276A, or N276K.
E294N +	K334A, K334R, K334Q, K334N, K334S, K334E, K334D, K334M, K334Y, K334W, K334H, K334V, or K334L.	E33A, E333Q, E333N, E333S, E333K, E333R, E333D, or E333G.	S324A, S324N, S324Q, S324K, or S324E.	N286Q, N286S, N286A, or N286D.	N276Q, N276A, or N276K.

** Note that table uses EU numbering as in Kabat.

Combination variants can also be constructed with the variants shown in the above tables in combination with the position 280 and position 290 variants (e.g. D280H, D280A, D280K, D280N, D280T, K290S, K290K, K290N, K290P, K290T, K290T, and K290V), or by combining the position 280 and 290 variants. The combination variants shown in Tables 1 and 2, and other combination variants may be tested for a given activity (e.g. FcR binding activity, ADCC activity, and C1q binding) in a variety of assays (See, Section IV. below). In this regard, useful combination variants may be identified.

In certain preferred embodiments, the combination variants of the present invention have one amino acid modification that increases Fc gamma receptor (FcγR) binding affinity, and one amino acid modification that increases neonatal Fc receptor (FcRn) binding affinity. In other embodiments, the combination variants of the present invention have one surface amino acid modification, and one non-surface amino acid modification. Additional combination variants may be generated by combining two or more of the amino acid modifications described herein, or at least one of the amino acid modifications described herein with those described in WO0042072.

IV. Variant Polypeptide Assays

The present invention provides various assays for screening Fc region variants. Screening assays may be used to find or confirm useful variants. For example, combination variants (See Tables 1 and 2) may be screened to find variants with increased FcR binding, or ADCC or CDC activity (e.g. increased or decreased ADCC or CDC activity). Also, variants with amino acid modifications in non-surface residues may also be screened (e.g. a variant with a least one surface amino acid modification and one non-surface amino acid modification may be screened). Also, as described below, the assays of the present invention may be employed to find or confirm variants that have beneficial therapeutic activity in a subject (e.g. such as a human with symptoms of an antibody or immunoadhesin responsive disease). A variety of assay types may be employed to evaluate any change in a variant compared to the parent polypeptide (See, screening assays provided in WO0042072, herein incorporated by reference). Further exemplary assays are described below.

In preferred embodiments, the variants of the present invention are antibodies that essentially retain the ability to bind antigen (via an unmodified antigen binding region or modified antigen binding region) compared to the nonvariant (parent) polypeptide (e.g. the binding capability is preferably no worse than about 20 fold or no worse than about 5 fold of that of the nonvariant polypeptide). The binding capability of the polypeptide variant to

antigen may be determined using techniques such as fluorescence activated cell sorting (FACS) analysis or radioimmunoprecipitation (RIA), for example.

Fc receptor (FcR) binding assays may be employed to evaluate the variants of the present invention. For example, binding of Fc receptors such as FcγRI, FcγRIIa, FcγRIIb, 5 FcγRIII, FcRn, etc., can be measured by titrating polypeptide variant and measuring bound polypeptide variant using an antibody which specifically binds to the polypeptide variant in a standard ELISA format (see Examples below). For example, a variant that comprises an antibody may be screened in a standard ELISA assay to determine binding to an FcR. A solid surface may be coated with an antigen. Excess antigen may be washed, and the 10 surface blocked. The variant polypeptide (antibody) is specific for this antigen, and therefore binds to the antigen-coated surface. Then an FcR conjugated to a label (e.g. biotin) may be added, and the surface washed. In the following step a molecule specific for the label on the FcR is added (e.g. avidin conjugated to an enzyme). Thereafter a substrate may be added in order to determine the amount of binding of the FcR to the variant 15 polypeptide. The results of this assay can be compared to the parent (non-variant) polypeptide's ability to bind the same FcR. In preferred embodiments, the FcR is selected from FcγRIIA, FcγRIIB, and FcγRIIIA for IgG, as these receptors (e.g. expressed recombinantly) may be successfully employed to screen the variants of the present invention. In fact, such binding assays with these preferred receptors unexpectedly allows 20 the identification of useful variants. It is unexpected that useful variants (e.g. with greater FcR binding or ADCC or CDC) are identified in such a fashion (See, Examples below) given that others have dismissed such assays (e.g. using FcγRIIA, FcγRIIB, and FcγRIIIA for IgG) as not reliable in an ELISA format (See, WO0042072, Example 1). In other preferred embodiments, the components for carrying out an ELISA (e.g. with FcγRIIA, 25 FcγRIIB, and FcγRIIIA for IgG) to screen variants are packaged in a kit (e.g. with instructions for use).

An antibody dependent cellular cytotoxicity (ADCC) assay may also be employed to screen the variants of the present invention. ADCC assays may be performed in vitro or in vivo. To assess ADCC activity of a polypeptide variant an in vitro ADCC assay may be 30 performed using varying effector: target ratios. An exemplary ADCC assay could use a target cell line expressing any of the following target antigens: CD20, CD22, CD33, CD40, CD63, EGF receptor, her-2 receptor, prostate-specific membrane antigen, Lewis Y carbohydrate, GD₂ and GD₃ gangliosides, lamp-1, CO-029, L6, and ephA2. Effector cells

may be obtained from a healthy donor (e.g. on the day of the experiment) and PBMC purified using Histopaque (Sigma). Target cells are then preincubated with an IgG variant at, for example, 1-10 µg/mL for about 30 minutes prior to mixing with effector cells at an effector:target ratios of, for example, 40:1, 20:1 and 10:1. ADCC activity may then be

5 measured colorimetrically using a Cytotoxicity Detection Kit (Roche Molecular Biochemicals) for the quantitation of cell death and lysis based upon the measurement of lactate dehydrogenase (LDH) activity released from the cytosol of damaged cells into the supernatant. ADCC activity may also be measured, for Chromium 51 loaded target cell

10 assays, by measuring the resulting Chromium 51 released. Antibody independent cellular cytotoxicity can be determined by measuring the LDH activity from target and effector cells in the absence of antibody. Total release may be measured following the addition of 1% triton X-100 to the mixture of target and effector cells. Incubation of the target and effector cells may be performed for an optimized period of time (4-18 hours) at 37 C in 5.0 % CO₂ and then be followed by centrifugation of the assay plates. The supernatants may then be

15 transferred to 96 well plates and incubated with LDH detection reagent for 30 minutes at 25 C. The sample absorbance may then be measured at 490 nm using a microplate reader. The percent cytotoxicity can then be calculated using the following equation: % cytotoxicity = experimental value - low control / high control - low control X 100%. The percent cytotoxicity of anti-CD20 and variants can then be compared directly with equal amount of

20 RITUXAN to provide a measurement of relative effectiveness. An exemplary ADCC assay could employ Ramos cells over-expressing the CD20 antigen (e.g. purchased from the American Type Culture Collection) as the source of target cells. Many variations of this assay are known in the art (See, e.g., Zuckerman et al., *CRC Crit Rev Microbiol* 1978;7(1):1-26, herein incorporated by reference).

25 Useful effector cells for such assays includes, but is not limited to, natural killer (NK) cells, macrophages, and other peripheral blood mononuclear cells (PBMC). Alternatively, or additionally, ADCC activity of the polypeptide variants of the present invention may be assessed in vivo, e.g., in a animal model such as that disclosed in Clynes et al. PNAS (USA) 95:652-656 (1998), herein incorporated by reference).

30 The ability of the variant to bind C1q and mediate complement dependent cytotoxicity (CDC) may be assessed. For example, to determine C1q binding, a C1q binding ELISA may be performed. An exemplary C1q binding assay is as follows. Assay plates may be coated overnight at 4 C with polypeptide variant or parental polypeptide (control) in coating buffer. The plates may then be washed and blocked. Following

washing, an aliquot of human C1q may be added to each well and incubated for 2 hrs at room temperature. Following a further wash, 100 ul of a sheep anti-complement C1q peroxidase-conjugated antibody may be added to each well and incubated for 1 hour at room temperature. The plate may again be washed with wash buffer and 100 ul of substrate
5 buffer containing OPD (O-phenylenediamine dihydrochloride (Sigma)) may be added to each well. The oxidation reaction, observed by the appearance of a yellow color, may be allowed to proceed for an optimized time (2-60 minutes) and stopped by the addition of 100 ul of 4.5 N H₂SO₄. The absorbance may then be read at 492 nm and the background absorbance at 405 nm subtracted from this value.

10 The variants of the present invention may also be screened for complement activation. To assess complement activation, a complement dependent cytotoxicity (CDC) assay may be performed (See, e.g. Gazzano-Santoro et al., J. Immunol. Methods, 202:163 (1996), herein incorporated by reference). For example, various concentrations of the polypeptide variant and human complement may be diluted with buffer. Cells which
15 express the antigen to which the polypeptide variant binds may be diluted to a density of $\sim 1 \times 10^6$ cells/ml. Mixtures of polypeptide variant, diluted human complement and cells expressing the antigen may be added to a flat bottom tissue culture 96 well plate and allowed to incubate for 2 hours at 37 C and 5% CO₂ to facilitate complement mediated cell lysis. 50 ul of alamar blue (Accumed International) may then be added to each well and
20 incubated overnight at 37 C. The absorbance may be measured using a 96-well fluorimeter with excitation at 530 nm and emission at 590 nm. The results may be expressed in relative fluorescence units (RFU). The sample concentrations may be computed from a standard curve and the percent activity as compared to nonvariant polypeptide may be reported for the polypeptide variant of interest.

25 In preferred embodiments, the variant has a higher binding affinity for human C1q than the parent polypeptide. Such a variant may display, for example, about two-fold or more, and preferably about five-fold or more, improvement in human C1q binding compared to the parent polypeptide (e.g. at the IC₅₀ values for these two molecules). For example, human C1q binding may be about two-fold to about 500-fold, and preferably from
30 about two-fold or from about five-fold to about 1000-fold improved compared to the parent polypeptide.

In other preferred embodiments, variants are found that exhibit 2-fold, 25-fold, 50-fold, 100-fold or 1000-fold reduction in C1q binding compared to a control (parental) antibody having a nonmutated IgG1 Fc region. In even more preferred embodiments, the

polypeptide variant does not bind C1q (e.g., 100ug/ml of the polypeptide variant displays about 100 fold or more reduction in C1q binding compared to 100ug/ml of the control antibody).

In certain embodiments, the variants of the present invention do no activate
5 complement. For example, a polypeptide variant displays about 0-10% CDC activity in this assay compared to a control antibody having a nonmutated IgG1 Fc region. Preferably the variant does not appear to have any CDC activity (e.g. above background) in the above CDC assay. In other embodiments, the variants of the present invention are found to have enhanced CDC compared to a parent polypeptide [e.g., displaying about two-fold to about
10 100-fold (or greater) improvement in CDC activity in vitro or in vivo when the IC50 values are compared].

The variants of the present invention may also be screened in vivo. Any type of in vivo assay may be employed. A particular example of one type of assay is provided below. This exemplary assay allows for preclinical evaluation of Fc variants in vivo. A variant to
15 be tested may be incorporated into the Fc region of a particular antibody known to have some activity. For example, a variant may be incorporated into the Fc region of an anti-CD20 IgG by mutagenesis. This allows a parental IgG and Fc variant IgG to be compared directly with RITUXAN (known to promote tumor regression). The preclinical evaluation may be done in 2 phases (a pharmacokinetic and pharmacodynamic phase). The goal of the
20 Phase I pharmacokinetic studies is to determine if there are differences in the clearance rate between an Fc variant IgG and the antibody with known in vivo activity (e.g. RITUXAN). Differences in clearance rate may cause differences in the steady-state level of IgG in serum. As such, if differences in steady-state concentrations are detected these should be normalized to enable accurate comparisons to be made. The goal of the Phase II
25 pharmacodynamic studies is to determine the effect of the Fc mutations upon, in this case, tumor growth. Previous studies with RITUXAN used a single dose which completely inhibited tumor growth. Because this does not allow quantitative differences to be measured, a dose range should be employed.

Phase I Pharmacokinetic comparison of an Fc variant, the wild type parental Fc, and
30 RITUXAN may be performed in the following manner. First, 40 µg per animal may be injected intravenously and the plasma level of the IgG quantitated at 0, .25, .5, 1, 24, 48, 168, and 336 hrs. The data may be fitted, for example, using a pharmacokinetic program (WinNonLin) using a zero lag two compartment pharmacokinetic model to obtain the clearance rate. Clearance rate may be used to define steady state plasma level with the

following equation: $C = \text{Dose} / (\text{Clearance rate} \times \tau)$, where τ is the interval between doses and C is the plasma level at steady state. Pharmacokinetic experiments may be performed in non-tumor bearing mice with, for example, a minimum of 5 mice per time point.

An animal model may be employed for the next phase in the following manner. The
5 right flank of CB17-SCID mice may be implanted with 10^6 Raji cells subcutaneously. Intravenous bolus of the Fc variant, the wild type Fc, and RITUXAN may be commenced immediately after implantation and continued until the tumor size is greater than 2 cm in diameter. Tumor volume may be determined every Monday, Wednesday and Friday by
10 measuring the length, width, and depth of the tumor using a caliper (tumor volume = $W \times L \times D$). A plot of tumor volume versus time will give the tumor growth rate for the pharmacodynamic calculation. A minimum of about 10 animals per group should be used.

Phase II pharmacodynamic comparison of the Fc variant, the wild type Fc, and RITUXAN may be performed in the following manner. Based on published data, RITUXAN at 10 $\mu\text{g/g}$ weekly completely inhibited tumor growth in vivo (Clynes et al., Nat.
15 Med. 2000 Apr;6(4):443-6, 2000, herein incorporated by reference). Therefore, a weekly dose range of 10 $\mu\text{g/g}$, 5 $\mu\text{g/g}$, 1 $\mu\text{g/g}$, 0.5 $\mu\text{g/g}$, and 0 $\mu\text{g/g}$ may be tested. The steady state plasma level at which tumor growth rate is inhibited by 50% may be graphically determined by the relationship between steady state plasma level and effectiveness. The steady state
20 plasma level may be calculated as described above. If necessary, τ may be adjusted accordingly for each Fc variant and the Fc wild type depending on their pharmacokinetic properties to achieve comparable steady state plasma level as RITUXAN. Statistical improved pharmacodynamic values of the Fc variant in comparison to the parental polypeptide (e.g. Fc wild type) and RITUXAN will generally indicate that Fc variant confers improved activity *in vivo*.

25 In further embodiments, the variants of the present invention are screened such that variants that are useful for therapeutic use in at least two species are identified. Such variants are referred to herein as "dual-species improved variants", and are particularly useful for identifying variants that are therapeutic in humans, and also demonstrate (or are likely to demonstrate) efficacy in an animal model. In this regard, the present invention
30 provides methods for identifying variants that have a strong chance of being approved for human clinical testing since animal model data will likely support any human testing applications made to governmental regulatory agencies (e.g. U.S. Food and Drug Administration).

In certain embodiments, dual-species improved variants are identified by first performing an ADCC assay using human effector cells to find improved variants, and then performing a second ADCC assay using mouse, rat, or non-human primate effector cells to identify a sub-set of the improved variants that are dual-species improved variants. In some
5 embodiments, the present invention provides methods for identifying dual-species improved variants, comprising; a) providing; i) target cells, ii) a composition comprising a candidate variant of a parent polypeptide having at least a portion of an Fc region, wherein the candidate variant comprises at least one amino acid modification in the Fc region, and wherein the candidate variant mediates target cell cytotoxicity in the presence of a first
10 species (e.g. human) of effector cells more effectively than the parent polypeptide, and iii) second species (e.g. mouse, rat, or non-human primate) effector cells, and b) incubating the composition with the target cells under conditions such that the candidate variant binds the target cells thereby generating candidate variant bound target cells, c) mixing the second species effector cells with the candidate variant bound target cells, and d) measuring target
15 cell cytotoxicity mediated by the candidate variant. In certain embodiments, the method further comprises step e) determining if the candidate variant mediates target cell cytotoxicity in the presence of the second species effector cells more effectively than the parent polypeptide. In some embodiments, the method further comprises step f) identifying a candidate variant as a dual-species improved variant that mediates target cell cytotoxicity
20 in the presence of the second species effector cells more effectively than the parent polypeptide. In preferred embodiments, the dual-species variants identified are then screened *in vivo* in one or more animal assays.

In certain embodiments, dual-species improved variants are identified by performing any of the assays above using human components (e.g. human cells, human Fc receptors,
25 etc.) to identify improved variants, and then running the same assay (or a different assay) with non-human animal components (e.g. mouse cells, mouse Fc receptors, etc.). In this regard, a sub-set of variants that perform well according to a given criteria in both human based assays and a second species based assays can be identified.

An exemplary process for identifying dual-species improved variants is as follows.
30 First, a nucleic acid sequence encoding at least a portion of an IgG Fc region is mutated such that the amino acid sequence expressed has at least one amino acid change, thereby generating a variant. This expressed IgG variant is then captured via antigen on an assay plate. Next, the captured variant is screened for soluble human FcγRIII binding using ELISA. If the variant demonstrates improved or comparable (compared to a non-mutated

parental Fc region) FcγRIII binding, then the variant is screened for human FcγRIII binding using ELISA. The relative specificity ratio for the variant may then be calculated. Next, an ADCC assay is performed with the variant using human PBMCs or a subset (NK cells or macrophages, for example). If enhanced ADCC activity is found, then the variant is
5 screened in a second ADCC assay using mouse or rat PBMCs. Alternatively, or in addition, an assay can be performed with the variant for binding to cloned rodent receptors or cell lines. Finally, if the variant is found to be improved in the second assay, making it a dual-improved variant, then the variant is screened in vivo in mice or rats.

10 V. Exemplary Variant Fc Region Containing Molecules

The variant Fc regions of the present invention may be part of larger molecules. The larger molecules may be, for example, monoclonal antibodies, polyclonal antibodies, chimeric antibodies, humanized antibodies, bispecific antibodies, immunoadhesins, etc. As such, it is evident that there is a broad range of applications for the variant Fc regions of the
15 present invention.

A. Antibodies Containing Variant Fc Regions

In preferred embodiments, the variant Fc region containing molecule (e.g. polypeptide) is an antibody. Techniques for producing antibodies are described below.
20

(i) Antigen selection and preparation

Generally, when the variant Fc region containing molecule is an antibody, the antibody is directed against an antigen of interest. Preferably, the antigen is a polypeptide and administration of the antibody to a mammal suffering from a disease or disorder can
25 result in a therapeutic benefit in that mammal. However, antibodies directed against nonpolypeptide antigens (such as tumor associated glycolipid antigens; see US Patent 5,091,178, herein incorporated by reference), may also be employed.

Exemplary antigens include, but are not limited to, molecules such as renin; a
30 growth hormone, including human growth hormone and bovine growth hormone; growth hormone releasing factor; parathyroid hormone; thyroid stimulating hormone; lipoproteins; alpha-1- antitrypsin; insulin A-chain; insulin B-chain; proinsulin; follicle stimulating hormone; calcitonin; luteinizing hormone; glucagon; clotting factors such as factor VIII, factor IX, tissue factor (TF), and von Willebrands factor; anti-clotting factors such as

Protein C; atrial natriuretic factor; lung surfactant; a plasminogen activator, such as urokinase or human urine or tissue-type plasminogen activator (t-PA); bombesin; thrombin; hemopoietic growth factor; tumor necrosis factor-alpha and -beta; enkephalinase; RANTES (regulated on activation normally T-cell expressed and secreted); human macrophage inflammatory protein (MIP-1-alpha); a serum albumin such as human serum albumin; 5 Muellerian-inhibiting substance; relaxin A-chain; relaxin B-chain; prorelaxin; mouse gonadotropin-associated peptide; a microbial protein, such as beta-lactamase; DNase; IgE; a cytotoxic T-lymphocyte associated antigen (CTLA), such as CTLA-4; inhibin; activin; vascular endothelial growth factor (VEGF); receptors for hormones or growth factors; 10 protein A or D; rheumatoid factors; a neurotrophic factor such as bone-derived neurotrophic factor (BDNF), neurotrophin-3,-4,-5, or-6 (NT-3, NT-4, NT-5, or NT-6), or a nerve growth factor; platelet-derived growth factor (PDGF); fibroblast growth factor such as α FGF and β FGF; epidermal growth factor (EGF); transforming growth factor (TGF) such as TGF-alpha and TGF beta, including TGF- 1, TGF- 2, TGF- 3, TGF- 4, or TGF- 5; insulin-like 15 growth factor-I and-II (IGF-I and IGF-II); des (1-3)-IGF-I (brain IGF-I), insulin-like growth factor binding proteins; CD proteins such as CD3, CD4, CD8, CD19 and CD20; erythropoietin; osteoinductive factors; immunotoxins; a bone morphogenetic protein (BMP); an interferon such as interferon-alpha,-beta, and-gamma; colony stimulating factors (CSFs), e. g., M-CSF, GM-CSF, and G-CSF; interleukins (ILs), e.g., IL-1 to IL-10; 20 superoxide dismutase; T-cell receptors; surface membrane proteins; decay accelerating factor; viral antigen such as, for example, a portion of the AIDS envelope; transport proteins; homing receptors; addressins; regulatory proteins; integrins such as CD11 a, CD11 b, CD11c, CD18, an ICAM, VLA-4 and VCAM; a tumor associated antigen such as HER2, HER3 or HER4 receptor; a member of an apoptosis pathway; and fragments of any of the 25 above-listed polypeptides.

Preferred antigens include, but are not limited to, CD proteins such as CD3, CD4, CD8, CD19, CD20 and CD34; members of the ErbB receptor family such as the EGF receptor, HER2, HER3 or HER4 receptor; cell adhesion molecules such as LFA-1, Mac1, p150.95, VLA-4, ICAM-1, VCAM, α 4/p7 integrin, and (Xv/p3 integrin including either a or 30 subunits thereof (e.g. anti-CD11a, anti-CD18 or anti-CD11b antibodies); growth factors such as VEGF; tissue factor (TF); alpha interferon (α -IFN); an interleukin, such as IL-8; IgE; blood group antigens; flk2/flt3 receptor; obesity (OB) receptor; mpl receptor; CTLA-4; protein C etc.

Soluble antigens or fragments thereof, optionally conjugated to other molecules, can be used as immunogens for generating antibodies. For transmembrane molecules, such as receptors, fragments of these (e.g. the extracellular domain of a receptor) can be used as the immunogen. Alternatively, cells expressing the transmembrane molecule can be used as the immunogen. Such cells can be derived from a natural source (e.g. cancer cell lines) or may be cells which have been transformed by recombinant techniques to express the transmembrane molecule. Other antigens and forms thereof useful for preparing antibodies will be apparent to those in the art.

10 (ii) *Polyclonal Antibodies*

The present invention provides polyclonal antibodies with variant Fc regions. For example, a human immunoglobulin repertoire containing modified G1 constant regions may be transplanted into immunoglobulin-inactivated mice, resulting in mice expressing an IgG repertoire containing modified Fc regions (see e.g. Mendez, MJ et al., Nature Genetics 15:146 (1997), herein incorporated by reference). Polyclonal antibodies are preferably raised in animals by multiple subcutaneous (sc) or intraperitoneal (ip) injections of the relevant antigen and an adjuvant. It may be useful to conjugate the relevant antigen to a protein that is immunogenic in the species to be immunized (e.g. keyhole limpet hemocyanin, serum albumin, bovine thyroglobulin, or soybean trypsin inhibitor) using a bifunctional or derivitizing agent (e.g. maleimidobenzoyl sulfosuccinimide ester for conjugation through cystein residues, N-hydroxysuccinimide for conjugation through lysine residues, glutaraldehyde, succinic anhydride, SOCl_2 , or $\text{R1N}=\text{C}=\text{NR}$, where R and R1 are different alkyl groups).

Examples of a general immunization protocol for a rabbit and mouse are as follows. Animals are immunized against the antigen, immunogenic conjugates, or derivatives by combining, for example, 100 μg or 5 μg of the protein or conjugate (e.g. for a rabbit or mouse respectively) with 3 volumes of Freund's complete adjuvant and injecting the solution intradermally at multiple sites. One month later the animals are boosted with 1/5 or 1/10 the original amount of peptide or conjugate in Freund's complete adjuvant by subcutaneous injection at multiple sites. Seven to fourteen days later the animals are bled and the serum is assayed for antibody titer. Animals are boosted until the titer plateaus. Preferably, the animal is boosted with the conjugate of the same antigen, but conjugated to a different protein and/or through a different cross-linking reagent. Conjugates also can be

made in recombinant cell culture as protein fusions. In addition, aggregating agents such as alum are suitably used to enhance the immune response.

(iii) Monoclonal antibodies

5 The present invention provides monoclonal antibodies with variant Fc regions. Monoclonal antibodies may be made in a number of ways, including using the hybridoma method (e.g. as described by Kohler et al., *Nature*, 256: 495, 1975, herein incorporated by reference), or by recombinant DNA methods (e.g., U. S. Patent No. 4,816,567, herein incorporated by reference).

10 In the hybridoma method, a mouse or other appropriate host animal, such as a hamster or macaque monkey, is immunized to elicit lymphocytes that produce or are capable of producing antibodies that will specifically bind to the protein used for immunization. Alternatively, lymphocytes may be immunized in vitro. Lymphocytes then are fused with myeloma cells using a suitable fusing agent, such as polyethylene glycol, to
15 form a hybridoma cell. The hybridoma cells thus prepared are seeded and grown in a suitable culture medium that preferably contains one or more substances that inhibit the growth or survival of the unfused, parental myeloma cells. For example, if the parental myeloma cells lack the enzyme hypoxanthine guanine phosphoribosyl transferase (HGPRT or HPRT), the culture medium for the hybridomas typically will include hypoxanthine,
20 aminopterin, and thymidine (HAT medium), which substances prevent the growth of HGPRT-deficient cells.

 Preferred myeloma cells are those that fuse efficiently, support stable high-level production of antibody by the selected antibody-producing cells, and are sensitive to a medium such as HAT medium. Among these, preferred myeloma cell lines are murine
25 myeloma lines, such as those derived from MOPC-21 and MPC-11 mouse tumors available from the Salk Institute Cell Distribution Center, San Diego, California USA, and SP-2 or X63-Ag8-653 cells available from the American Type Culture Collection, Rockville, Maryland USA. Human myeloma and mouse-human heteromyeloma cell lines also have been described for the production of human monoclonal antibodies (e.g., Kozbor, J.
30 *Immunol.*, 133: 3001 (1984), herein incorporated by reference).

 Culture medium in which hybridoma cells are growing is assayed for production of monoclonal antibodies directed against the antigen. Preferably, the binding specificity of monoclonal antibodies produced by hybridoma cells is determined by immunoprecipitation or by an in vitro binding assay, such as radioimmunoassay (RIA) or enzyme-linked

immunoabsorbent assay (ELISA). After hybridoma cells are identified that produce antibodies of the desired specificity, affinity, and/or activity, the clones may be subcloned by limiting dilution procedures and grown by standard methods. Suitable culture media for this purpose include, for example, D-MEM or RPMI-1640 medium. In addition, the
5 hybridoma cells may be grown *in vivo* as ascites tumors in an animal. The monoclonal antibodies secreted by the subclones are suitably separated from the culture medium, ascites fluid, or serum by conventional immunoglobulin purification procedures such as, for example, protein A-Sepharose, hydroxylapatite chromatography, gel electrophoresis, dialysis, or affinity chromatography.

10 DNA encoding the monoclonal antibodies is readily isolated and sequenced using conventional procedures (e.g., by using oligonucleotide probes that are capable of binding specifically to genes encoding the heavy and light chains of the monoclonal antibodies). The hybridoma cells serve as a preferred source of such DNA. Once isolated, the DNA may be placed into expression vectors, which are then transfected into host cells such as E.
15 coli cells, simian COS cells, Chinese hamster ovary (CHO) cells, or myeloma cells that do not otherwise produce immunoglobulin protein, to obtain the synthesis of monoclonal antibodies in the recombinant host cells. Recombinant production of antibodies is described in more detail below.

In some embodiments, antibodies or antibody fragments are isolated from antibody
20 phage libraries generated using the techniques described in, for example, McCafferty et al., *Nature*, 348: 552554 (1990). Clackson et al., *Nature*, 352:624-628 (1991) and Marks et al., *J. Mol. Biol.*, 222: 581-597 (1991) describe the isolation of murine and human antibodies, respectively, using phage libraries. Subsequent publications describe the production of high affinity (nM range) human antibodies by chain shuffling (Marks et. al., *BioTechnology*, 10:
25 779-783 (1992)), as well as combinatorial infection and *in vivo* recombination as a strategy for constructing very large phage libraries (e.g., Waterhouse et al., *Nuc. Acids. Res.*, 21: 2265-2266 (1993)). Thus, these techniques, and similar techniques, are viable alternatives to traditional monoclonal antibody hybridoma techniques for isolation of monoclonal antibodies.

30 Also, the DNA may be modified, for example, by substituting the coding sequence for human heavy- and light-chain constant domains in place of the homologous murine sequences (e.g., U. S. Patent No. 4,816,567, and Morrison, et al., *Proc. Nat. Acad. Sci USA*, 81: 6851 (1984), both of which are hereby incorporated by reference), or by

covalently joining to the immunoglobulin coding sequence all or part of the coding sequence for a non-immunoglobulin polypeptide.

Typically such non-immunoglobulin polypeptides are substituted for the constant domains of an antibody, or they are substituted for the variable domains of one antigen-combining site of an antibody to create a chimeric bivalent antibody comprising one
5 antigen-combining site having specificity for an antigen and another antigen-combining site having specificity for a different antigen.

(iv) Humanized and human antibodies

10 The present invention provides humanized and human antibodies with variant Fc regions. In preferred embodiments, a humanized antibody comprises human antibody amino acid sequences together with amino acid residues that are not from a human antibody. In some embodiments, the human sequences in a humanized antibody comprise the framework regions (FRs) and the sequences or residues that are not from a human
15 antibody comprise one or more complementarity-determining regions (CDRs).

It is worth noting that FRs and CDRs can be defined based on amino acid residue numbering in the heavy and light chain variable regions. The term complementarity determining region, or CDR is intended to mean the non-contiguous antigen combining sites found within the variable region of both heavy and light chain polypeptides. These
20 regions have been defined by Kabat et al. (J. Biol. Chem. 252:6609-6616 (1977) and Kabat et al. Sequences of Proteins of Immunological Interest (1991); "Kabat"), Chothia et al. (J. Mol. Biol. 196:901-917 (1987); "Chothia") and MacCallum et al. (J. Mol. Biol. 262:732-745 (1996); "MacCallum"), where the definitions include overlapping or subsets of amino acid residues when compared against each other. Nevertheless, the application of any of
25 these definitions, alone (for example, the Kabat definition) or in combination (by way of example only, the combined definition of Kabat and Chothia) to refer to a CDR of an antibody (including a humanized antibody) is intended to be within the scope of the term as defined and used herein. The amino acid residues which encompass the CDRs as defined by each of the above cited references are set forth below in Table 6 as a comparison.

30

Table 6: CDR Definitions:

	Kabat	Chothia	MacCallum
V _H CDR1	31-35	26-32	30-35
V _H CDR2	50-65	53-55	47-58
V _H CDR3	95-102	96-101	93-101
V _L CDR1	24-34	26-32	30-36
V _L CDR2	50-56	50-52	46-55
V _L CDR3	89-97	91-96	89-96

Also, the term “framework” when used in reference to an antibody variable region is intended to mean all amino acid residues outside the CDR regions within the variable region of an antibody. Therefore, a variable region framework is between about 100-120 amino acids in length but is intended to reference only those amino acids outside of the CDRs. The term “framework region” is intended to mean each domain of the framework that is separated by the CDRs. Therefore, for the specific example of a heavy chain variable region and for the CDRs as defined by Kabat, framework region 1 (FR1) corresponds to the domain of the variable region encompassing amino acids 1-30; region 2 (FR2) corresponds to the domain of the variable region encompassing amino acids 36-49; region 3 (FR3) corresponds to the domain of the variable region encompassing amino acids 66-94, and region 4 (FR4) corresponds to the domain of the variable region from amino acid 103 to the end of the variable region. The framework regions for the light chain are similarly separated by each of the light chain variable region CDRs. Similarly, using the definition of CDRs by Chothia or MacCallum, or any combination of CDR definitions, the framework boundaries are separated by the respective CDR termini as described above. Notwithstanding the multiple definitions of CDRs, in some embodiments, it is preferred to use the Kabat definition to define CDRs.

The residues in a humanized antibody that are not from a human antibody may be residues or sequences imported from or derived from another species (including but not limited to mouse), or these sequences may be random amino acid sequences (e.g. generated from randomized nucleic acid sequences), which are inserted into the humanized antibody sequence. As noted above, the human amino acid sequences in a humanized antibody are preferably the framework regions, while the residues which are not from a human antibody (whether derived from another species or random amino acid sequences) preferably

correspond to the CDRs. However, in some embodiments, one or more framework regions may contain one or more non-human amino acid residues. In cases of alterations or modifications (e.g. by introduction of a non-human residue) to an otherwise human framework, it is possible for the altered or modified framework region to be adjacent to a
5 modified CDR from another species or a random CDR sequence, while in other embodiments, an altered framework region is not adjacent to an altered CDR sequence from another species or a random CDR sequence. In preferred embodiments, the framework sequences of a humanized antibody are entirely human (i.e. no framework changes are made to the human framework).

10 Non-human amino acid residues from another species, or a random sequence, are often referred to as "import" residues, which are typically taken from an "import" variable domain. Humanization can be essentially performed following the method of Winter and co-workers (e.g., Jones et al., Nature, 321: 522-525 (1986); Riechmann et al., Nature, 332: 323-327 (1988); Verhoeyen et al., Science, 239: 1534-1536 (1988), all of which are hereby
15 incorporated by reference), by substituting rodent (or other mammal) CDRs or CDR sequences for the corresponding sequences of a human antibody. Also, antibodies wherein substantially less than an intact human variable domain has been substituted by the corresponding sequence from a non-human species may also be generated (e.g. 4,816,567, hereby incorporated by reference). In practice, humanized antibodies are typically human
20 antibodies in which some CDR residues and possibly some FR residues are substituted by residues from analogous sites in rodent antibodies, or, as noted above, in which CDR sequences have been substituted by random sequences. By way of non-limiting example only, methods for conferring donor CDR binding affinity onto an antibody acceptor variable region framework are described in WO 01/27160 A1, herein incorporated by reference and
25 in US applications 09/434,870 and 09/982,464, all of which are herein incorporated by reference.

The choice of human variable domains, both light and heavy, to be used in making the humanized antibodies is important to reduce antigenicity. According to the so-called "best-fit" method, the sequence of the variable domain of a rodent antibody to be humanized
30 is screened against the entire library of known human variable-domain sequences. The human sequence which is closest to that of the rodent is then accepted as the human framework (FR) for the humanized antibody (e.g., Sims et al., J. Immunol., 151: 2296 (1993), and Chothia et al., J. Mol. Biol., 196: 901 (1987), both of which are hereby incorporated by reference). Another method uses a particular framework derived from the

consensus sequence of all human antibodies of a particular subgroup of light or heavy chains. The same framework may be used for several different humanized antibodies (e.g., Carter et al., Proc. Natl. Acad. Sci. USA, 89: 4285 (1992); Presta et al., J. Immunol., 151: 2623 (1993), both of which are hereby incorporated by reference).

5 In other embodiments, there is no need to “pre-select” a particular human antibody framework (*i.e.* there is no need to select a human framework with the closest homology or sequence identity to a given candidate antibody to be humanized). In these embodiments, a common or universal human framework may be used to accept one or more non-human CDRs. In the preferred embodiment, a single universal, fully human framework is used as
10 the framework for all antibodies to be humanized, regardless of its homology to the framework sequence(s) of the candidate antibodies. In this regard, humanized antibodies may be generated without making any changes in the framework region. This universal, fully human framework can then accept one or more CDR sequences. In one embodiment, the one or more CDR sequences are CDR sequences from an antibody from another species
15 (*e.g.* mouse or rat) which have been modified in comparison to the corresponding CDR in the intact antibody from the other species (*i.e.* there is simultaneous introduction of the CDR and modification of the CDR being introduced into the universal human framework). The modification corresponds to one or more amino acid changes (in the modified CDR) in comparison to the corresponding CDR in the intact antibody from the other species. In one
20 embodiment, all amino acid residues in the CDR are included in a library, while in other embodiments, not all of the CDR amino acid residues are included in a library. In another embodiment, the one or more CDR sequences are random sequences, which substitute for CDR sequences.

In preferred embodiments, antibodies are humanized with retention of high affinity
25 for the antigen and other favorable biological properties. In some embodiments, the affinity of the humanized antibody for the antigen is higher than the affinity of the corresponding non-humanized, intact antibody or fragment or portion thereof (*e.g.* the candidate rodent antibody). In this regard, in some embodiments, humanized antibodies are prepared by a process of analysis of the parental sequences and various conceptual humanized products
30 using three-dimensional models of the parental and humanized sequences. Three-dimensional immunoglobulin models are commonly available and are familiar to those skilled in the art. Computer programs are available which illustrate and display probable three-dimensional conformational structures of selected candidate immunoglobulin sequences. Inspection of these displays permits analysis of the likely role of the residues in

the functioning of the candidate immunoglobulin sequence, i.e., the analysis of residues that influence the ability of the candidate immunoglobulin to bind its antigen. In this way, FR residues can be selected and combined from the recipient and import sequences so that the desired antibody characteristic, such as increased affinity for the target antigen (s), is
5 achieved. In general, the CDR residues are directly and most substantially involved in influencing antigen binding.

A variety of specific methods, well known to one of skill in the art, may be employed to introduce antibody CDRs (or random sequences substituting for antibody CDRs) into antibody frameworks (see, for example, US applications 09/434,879 and
10 09/982,464). In some embodiments, overlapping oligos may be used to synthesize an antibody gene, or portion thereof (for example, a gene encoding a humanized antibody). In other embodiments, mutagenesis of an antibody template may be carried out using the methods of Kunkel (infra), for example to introduce a modified CDR or a random sequence to substitute for a CDR. In some embodiments, light and heavy chain variable regions are
15 humanized separately, and then co-expressed as a humanized variable region. In other embodiments, humanized variable regions make-up the variable region of an intact antibody. In some embodiments, the Fc region of the intact antibody comprising a humanized variable region has been modified (e.g. at least one amino acid modification has been made in the Fc region). For example, an antibody that has been humanized with
20 randomized CDR and no framework changes may comprise at least one amino acid modification in the Fc region.

In other embodiments, transgenic animals (e.g., mice) that are capable, upon immunization, of producing a full repertoire of human antibodies in the absence of endogenous immunoglobulin production are employed. For example, it has been described that the
25 homozygous deletion of the antibody heavy-chain joining region (JH) gene in chimeric and germ- line mutant mice results in complete inhibition of endogenous antibody production. Transfer of the human germ-line immunoglobulin gene array in such germ-line mutant mice will result in the production of human antibodies upon antigen challenge (See, e.g., Jakobovits et al., Proc. Natl. Acad. Sci. USA, 90: 2551 (1993), and Jakobovits et al., Nature,
30 362: 255-258 (1993), both of which are hereby incorporated by reference). Human antibodies can also be derived from phage-display libraries (e.g., Hoogenboom et al., J. Mol. Biol., 227: 381 (1991), and Vaughan et al. Nature Biotech 14: 309 (1996), both of which are hereby incorporated by reference).

The present invention provides methods for generating humanized antibodies (and antibody fragments) that comprise at least one amino acid modification in the Fc region (as compared to a parental polypeptide having an Fc region). Discussed below are additional methods for generating such humanized antibodies. The present invention also provides
5 compositions comprising the antibodies and antibody fragments generated by these methods. Importantly, the humanization methods discussed below, and other humanization methods (e.g. discussed above), may be combined with the Fc variants of the present invention. In this regard, humanized antibodies with altered, unique Fc regions may be constructed according to the present invention.

10 In some embodiments, a method of constructing a population of altered heavy chain variable region encoding nucleic acids is provided, comprising: a) providing a representation of first and second reference amino acid sequences, the first reference sequence comprising the sequence of a donor heavy chain variable region, the donor variable region comprising i) framework regions and ii) three complementarity-determining
15 regions as defined by the combined definitions of Kabat and Chothia; the second reference sequence comprising the sequence of an acceptor heavy chain variable region comprising framework regions; b) synthesizing a) first oligonucleotides encoding portions of the framework regions of the acceptor heavy chain variable region, wherein the portions of the framework regions when compared to the second reference sequence are unmodified; and b)
20 a population of second oligonucleotides, each encoding i) at least a portion of a first complementarity-determining region that has been modified, the first complementarity-determining region selected from the group consisting of HCDR1, HCDR2 and HCDR3, wherein the modified first complementarity-determining region comprises a different amino acid at one or more positions when compared to the corresponding donor complementarity
25 determining regions of the first reference sequence and ii) one or more portions of unmodified framework regions which are capable of hybridizing to the first oligonucleotides; c) mixing the first oligonucleotides with the population of second oligonucleotides as to create overlapping oligonucleotides; and d) treating the overlapping oligonucleotides under conditions such that a population of altered heavy chain variable
30 region encoding nucleic acids is constructed, wherein the framework regions encoded by the altered heavy chain variable region encoding nucleic acids are unmodified with respect to the second reference sequence.

In some embodiments, the representation of first and second reference sequences is in electronic form. In some embodiments, the method further comprises the step of (E)

coexpressing the population of altered heavy chain variable region encoding nucleic acids with a light chain variable region encoding nucleic acid so as to produce a diverse population of altered heteromeric variable regions. In some embodiments, the synthesizing comprises chemically synthesizing. In some embodiments, the acceptor is human. In some
5 embodiments, the treating of step D) comprises extension by a polymerase.

In other embodiments, a method of constructing a population of altered light chain variable region encoding nucleic acids is provided, comprising: a) providing a representation of first and second reference amino acid sequences, the first reference sequence comprising the sequence of a donor light chain variable region, the donor variable
10 region comprising i) framework regions and ii) three complementarity-determining regions as defined by the combined definitions of Kabat and Chothia; the second reference sequence comprising the sequence of an acceptor light chain variable region comprising framework regions; b) synthesizing a) first oligonucleotides encoding portions of the framework regions of the acceptor light chain variable region, wherein the portions of the framework
15 regions when compared to the second reference sequence are unmodified; and b) a population of second oligonucleotides, each encoding i) at least a portion of a first complementarity-determining region that has been modified, the first complementarity-determining region selected from the group consisting of LCDR1, LCDR2 and LCDR3, wherein the modified first complementarity-determining region comprises a different amino
20 acid at one or more positions when compared to the corresponding donor complementarity determining regions of the first reference sequence and ii) one or more portions of unmodified framework regions which are capable of hybridizing to the first oligonucleotides; c) mixing the first oligonucleotides with the population of second oligonucleotides as to create overlapping oligonucleotides; and d) treating the overlapping
25 oligonucleotides under conditions such that a population of altered light chain variable region encoding nucleic acids is constructed, wherein the framework regions encoded by the altered light chain variable region encoding nucleic acids are unmodified with respect to the second reference sequence.

In some embodiments, the representation of first and second reference sequences is
30 in electronic form. In some embodiments, the method further comprises the step of (E) co-expressing the population of altered light chain variable region encoding nucleic acids with a heavy chain variable region encoding nucleic acid so as to produce a diverse population of altered heteromeric variable regions. In some embodiments, the synthesizing comprises

chemically synthesizing. In some embodiments, the acceptor is human. In some embodiments, the treating of step D) comprises extension by a polymerase.

In some embodiments, a method of constructing a population of altered heavy chain variable region encoding nucleic acids is contemplated, comprising: A) providing a representation of first and second reference amino acid sequences, the first reference sequence comprising the sequence of a donor heavy chain variable region, the donor variable region comprising i) framework regions and ii) three complementarity-determining regions as defined by the combined definitions of Kabat and Chothia; the second reference sequence comprising the sequence of an acceptor heavy chain variable region comprising framework regions; B) synthesizing a) a population of first oligonucleotides, each encoding at least a portion of a first complementarity-determining region selected from the group consisting of HCDR1, HCDR2 and HCDR3, wherein the modified first complementarity-determining region comprises a different amino acid at one or more positions when compared to the corresponding donor complementarity determining regions of the first reference sequence; and b) second oligonucleotides encoding i) portions of the framework regions of the acceptor heavy chain variable region, wherein the portions of the framework regions when compared to the reference sequence are unmodified and ii) one or more portions of a complementarity determining region which are capable of hybridizing to the population of first oligonucleotides; C) mixing the population of first oligonucleotides with the second oligonucleotides as to create overlapping oligonucleotides; and D) treating the overlapping oligonucleotides under conditions such that a population of altered heavy chain variable region encoding nucleic acids is constructed, wherein the framework regions encoded by the altered heavy chain variable region encoding nucleic acids are unmodified with respect to the second reference sequence.

In some embodiments, the representation of first and second reference sequences is in electronic form. In some embodiments, the method further comprises the step of (E) coexpressing the population of altered heavy chain variable region encoding nucleic acids with a light chain variable region encoding nucleic acid so as to produce a diverse population of altered heteromeric variable regions. In some embodiments, the synthesizing comprises chemically synthesizing. In some embodiments, the acceptor is human. In some embodiments, the treating of step D) comprises extension by a polymerase.

In other embodiments, a method of constructing a population of altered light chain variable region encoding nucleic acids is provided, comprising: A) providing a representation of first and second reference amino acid sequences, the first reference

sequence comprising the sequence of a donor light chain variable region, the donor variable region comprising i) framework regions and ii) three complementarity-determining regions as defined by the combined definitions of Kabat and Chothia; the second reference sequence comprising the sequence of an acceptor light chain variable region comprising framework regions; B) synthesizing a) a population of first oligonucleotides, each encoding at least a portion of a first complementarity-determining region selected from the group consisting of L1CDR1, L1CDR2 and L1CDR3, wherein the modified first complementarity-determining region comprises a different amino acid at one or more positions when compared to the corresponding donor complementarity determining regions of the first reference sequence; and b) second oligonucleotides encoding i) portions of the framework regions of the acceptor light chain variable region, wherein the portions of the framework regions when compared to the reference sequence are unmodified and ii) one or more portions of a complementarity determining region which are capable of hybridizing to the population of first oligonucleotides; C) mixing the population of first oligonucleotides with the second oligonucleotides as to create overlapping oligonucleotides; and D) treating the overlapping oligonucleotides under conditions such that a population of altered light chain variable region encoding nucleic acids is constructed, wherein the framework regions encoded by the altered light chain variable region encoding nucleic acids are unmodified with respect to the second reference sequence.

In some embodiments, the representation of first and second reference sequences is in electronic form. In some embodiments, the method further comprises the step of (E) coexpressing the population of altered light chain variable region encoding nucleic acids with a heavy chain variable region encoding nucleic acid so as to produce a diverse population of altered heteromeric variable regions. In some embodiments, the synthesizing comprises chemically synthesizing. In some embodiments, the acceptor is human. In some embodiments, the treating of step D) comprises extension by a polymerase.

In other embodiments, a method of constructing a population of altered heavy chain variable region encoding nucleic acids is contemplated, comprising: a) providing a representation of first and second reference amino acid sequences, the first reference sequence comprising the sequence of a donor heavy chain variable region, the donor variable region comprising i) framework regions and ii) three complementarity-determining regions, the second reference sequence comprising a heavy chain variable region; b) synthesizing a population of altered heavy chain variable region antibody gene sequences, wherein the framework regions of the altered heavy chain variable regions are identical to

the framework regions of the second reference sequence and at least a first CDR of the altered antibody variable regions has been modified, wherein the modified first CDR comprises a different amino acid at one or more positions when compared to the corresponding donor CDR of the first reference sequence.

5 In some embodiments, the representation of first and second reference sequences is in electronic form. In some embodiments, the method further comprises the step of (E) coexpressing the population of altered heavy chain variable region encoding nucleic acids with a light chain variable region encoding nucleic acid so as to produce a diverse population of altered heteromeric variable regions. In some embodiments, the acceptor is
10 human. In some embodiments, the synthesizing involves the use of overlapping oligonucleotides. In some embodiments, the CDRs are defined by the Kabat definition.

 In some embodiments, a method of constructing a population of altered light chain variable region encoding nucleic acids is contemplated, comprising: a) providing a representation of first and second reference amino acid sequences, the first reference
15 sequence comprising the sequence of a donor light chain variable region, the donor variable region comprising i) framework regions and ii) three complementarity-determining regions; the second reference sequence comprising the sequence of an acceptor light chain variable region comprising framework regions; b) synthesizing a population of altered light chain variable region antibody gene sequences, wherein the framework regions of the altered light
20 chain variable regions are identical to the framework regions of the second reference sequence and at least a first CDR of the altered antibody light chain variable region has been modified, wherein the modified first CDR comprises a different amino acid at one or more positions when compared to the corresponding donor CDR of the first reference sequence.

25 In some embodiments, the representation of first and second reference sequences is in electronic form. In some embodiments, the method further comprises the step of (E) coexpressing the population of altered light chain variable region encoding nucleic acids with a heavy chain variable region encoding nucleic acid so as to produce a diverse population of altered heteromeric variable regions. In some embodiments, the acceptor is
30 human. In some embodiments, the synthesizing involves the use of overlapping oligonucleotides.

 In yet other embodiments, a method of constructing a population of altered heavy chain variable region encoding nucleic acids is contemplated, comprising: a) providing a representation of a reference amino acid sequence, the reference sequence comprising the

sequence of an acceptor heavy chain variable region comprising framework regions; b) synthesizing a population of altered heavy chain variable region antibody gene sequences, wherein the framework regions of the altered heavy chain variable regions are identical to the framework regions of the reference sequence and at least a first CDR of the altered
5 antibody variable regions comprises a random amino acid sequence.

In some embodiments, the representation of the reference sequence is in electronic form. In some embodiments, the method further comprising the step of (E) coexpressing the population of altered heavy chain variable region encoding nucleic acids with a light chain variable region encoding nucleic acid so as to produce a diverse population of altered
10 heteromeric variable regions. In some embodiments, the acceptor is human. In some embodiments, the synthesizing involves the use of overlapping oligonucleotides. In some embodiments, the CDRs are defined by the Kabat definition.

In other embodiments, a method of constructing a population of altered light chain variable region encoding nucleic acids is contemplated, comprising: a) providing a
15 representation of a reference amino acid sequence, the reference sequence comprising the sequence of an acceptor light chain variable region comprising framework regions; b) synthesizing a population of altered light chain variable region antibody gene sequences, wherein the framework regions of the altered light chain variable regions are identical to the framework regions of the reference sequence and at least a first CDR of the altered antibody
20 light chain variable regions comprises a random amino acid sequence.

In some embodiments, the representation of the reference sequence is in electronic form. In some embodiments, the method further comprises the step of (E) coexpressing the population of altered light chain variable region encoding nucleic acids with a heavy chain variable region encoding nucleic acid so as to produce a diverse population of altered
25 heteromeric variable regions. In some embodiments, the acceptor is human. In some embodiments, the synthesizing involves the use of overlapping oligonucleotides. In some embodiments, the CDRs are defined by the Kabat definition.

In yet other embodiments, a method of constructing a population of altered heavy chain variable region encoding nucleic acids is contemplated, comprising: a) providing a
30 representation of a reference amino acid sequence, the reference sequence comprising the sequence of a human acceptor heavy chain variable region comprising framework regions; b) synthesizing a population of altered heavy chain variable region antibody gene sequences, wherein the framework regions of the altered heavy chain variable regions are identical to the framework regions of the human reference sequence and at least a first CDR

of the altered antibody variable regions comprises a random amino acid sequence. In some embodiments, the representation of the human reference sequence is in electronic form. In some embodiments, the method further comprises the step of (E) coexpressing the population of altered heavy chain variable region encoding nucleic acids with a light chain variable region encoding nucleic acid so as to produce a diverse population of altered heteromeric variable regions. In some embodiments, the synthesizing involves the use of overlapping oligonucleotides. In some embodiments, the CDRs are defined by the Kabat definition.

In other embodiments, a method of constructing a population of altered light chain variable region encoding nucleic acids is contemplated, comprising: a) providing a representation of a reference amino acid sequence, the reference sequence comprising the sequence of a human acceptor light chain variable region comprising framework regions; b) synthesizing a population of altered light chain variable region antibody gene sequences, wherein the framework regions of the altered light chain variable regions are identical to the framework regions of the human reference sequence and at least a first CDR of the altered antibody light chain variable regions comprises a random amino acid sequence.

In some embodiments, the representation of the reference sequence is in electronic form. In some embodiments, the method further comprises the step of (E) coexpressing the population of altered light chain variable region encoding nucleic acids with a heavy chain variable region encoding nucleic acid so as to produce a diverse population of altered heteromeric variable regions. In some embodiments, the synthesizing involves the use of overlapping oligonucleotides. In some embodiments, the CDRs are defined by the Kabat definition.

In some embodiments, one or more framework regions are modified simultaneously with the introduction of one or more modified CDRs. In other embodiments, the modified Frameworks are adjacent to the modified CDRs.

In some embodiments, the present invention provides methods of constructing a population of altered heavy chain variable region encoding nucleic acids, comprising: a) providing a representation of first and second reference amino acid sequences, the first reference amino acid sequence comprising the sequence of a donor heavy chain variable region, the donor variable region comprising i) framework regions and ii) three complementarity-determining regions as defined by the combined definitions of Kabat and Chothia; the second reference amino acid sequence comprising the sequence of an acceptor heavy chain variable region comprising framework regions; b) synthesizing a) a first

population of oligonucleotides, comprising oligonucleotides encoding a modified heavy chain variable region framework region, or portion thereof, wherein the heavy chain variable region framework region, or portion thereof, contains a plurality of changed amino acids at one or more positions when compared to the acceptor framework region reference sequence, wherein the framework positions that are changed are selected from among the
5 acceptor framework positions of the second reference sequence that differ at the corresponding position compared to the donor framework positions of the first reference sequence; and b) a second population of oligonucleotides, each encoding i) at least one modified complementarity-determining region, or portion thereof, wherein the modified
10 complementarity-determining region, or portion thereof, comprises a different amino acid at one or more positions when compared to the corresponding donor complementarity-determining region amino acid reference sequence and ii) one or more portions of adjacent framework regions which are capable of hybridizing to the first population of oligonucleotides; and c) mixing the first and second populations of oligonucleotides so as to
15 create overlapping oligonucleotides; and d) treating the overlapping oligonucleotides under conditions such that a population of altered heavy chain variable region encoding nucleic acids is constructed. In certain embodiments, the representation of first and second reference sequences is in electronic form. In other embodiments, the methods further comprise the step of (e) coexpressing the population of altered heavy chain variable region
20 encoding nucleic acids with a light chain variable region encoding nucleic acid so as to produce a diverse population of altered heteromeric variable regions. In additional embodiments, the synthesizing comprises chemically synthesizing. In some embodiments, the acceptor is human. In preferred embodiments, the one or more of the diverse population of altered heteromeric variable regions are part of an antibody comprising an Fc region,
25 wherein the Fc region comprises at least one amino acid modification as compared to a parental polypeptide having an Fc region.

In other embodiments, the present invention provides methods of constructing a population of altered light chain variable region encoding nucleic acids, comprising: a) providing a representation of first and second reference amino acid sequences, the first
30 reference amino acid sequence comprising the sequence of a donor light chain variable region, the donor variable region comprising i) framework regions and ii) three complementarity-determining regions as defined by the combined definitions of Kabat and Chothia; the second reference amino acid sequence comprising the sequence of an acceptor light chain variable region comprising framework regions; b) synthesizing a) a first

population of oligonucleotides, comprising oligonucleotides encoding a modified light chain variable region framework region, or portion thereof, wherein the light chain variable region framework region, or portion thereof, contains a plurality of changed amino acids at one or more positions when compared to the acceptor framework region reference sequence, wherein the framework positions that are changed are selected from among the acceptor framework positions of the second reference sequence that differ at the corresponding position compared to the donor framework positions of the first reference sequence; and b) a second population of oligonucleotides, each encoding i) at least one modified complementarity-determining region, or portion thereof, wherein the modified complementarity-determining region, or portion thereof, comprises a different amino acid at one or more positions when compared to the corresponding donor complementarity-determining region amino acid reference sequence and ii) one or more portions of adjacent framework regions which are capable of hybridizing to the first population of oligonucleotides; and c) mixing the first and second populations of oligonucleotides so as to create overlapping oligonucleotides; and d) treating the overlapping oligonucleotides under conditions such that a population of altered light chain variable region encoding nucleic acids is constructed. In other embodiments, the representation of first and second reference sequences is in electronic form. In additional embodiments, the methods further comprise the step of (e) coexpressing the population of altered light chain variable region encoding nucleic acids with a heavy chain variable region encoding nucleic acid so as to produce a diverse population of altered heteromeric variable regions.

In some embodiments, the methods comprise a) providing a representation of first and second reference amino acid sequences, the first reference amino acid sequence comprising the sequence of a donor heavy chain variable region, the donor variable region comprising i) framework regions and ii) three complementarity-determining regions as defined by the combined definitions of Kabat and Chothia; the second reference amino acid sequence comprising the sequence of an acceptor heavy chain variable region comprising framework regions; b) synthesizing a) a first population of oligonucleotides, comprising oligonucleotides encoding a modified heavy chain variable region framework region, or portion thereof, wherein the heavy chain variable region framework region, or portion thereof, contains a plurality of changed amino acids at one or more positions when compared to the acceptor framework region reference sequence, wherein the framework positions that are changed are selected from among the acceptor framework positions of the second reference sequence that differ at the corresponding position compared to the donor

framework positions of the first reference sequence; and b) a second population of oligonucleotides, each encoding i) at least one modified complementarity-determining region, or portion thereof, wherein the modified complementarity-determining region, or portion thereof, comprises a different amino acid at one or more positions when compared
5 to the corresponding donor complementarity-determining region amino acid reference sequence and ii) one or more portions of adjacent framework regions which are capable of hybridizing to the first population of oligonucleotides; and c) mixing the first and second populations of oligonucleotides so as to create overlapping oligonucleotides; and d) extending the overlapping oligonucleotides with a DNA polymerase under conditions such
10 that a population of altered heavy chain variable region encoding nucleic acids is constructed.

In still other embodiments, the present invention provides methods of constructing a population of altered light chain variable region encoding nucleic acids, comprising: a) providing a representation of first and second reference amino acid sequences, the first
15 reference amino acid sequence comprising the sequence of a donor light chain variable region, the donor variable region comprising i) framework regions and ii) three complementarity-determining regions as defined by the combined definitions of Kabat and Chothia; the second reference amino acid sequence comprising the sequence of an acceptor light chain variable region comprising framework regions; b) synthesizing a) a first
20 population of oligonucleotides, comprising oligonucleotides encoding a modified light chain variable region framework region, or portion thereof, wherein the light chain variable region framework region, or portion thereof, contains a plurality of changed amino acids at one or more positions when compared to the acceptor framework region reference sequence, wherein the framework positions that are changed are selected from among the acceptor
25 framework positions of the second reference sequence that differ at the corresponding position compared to the donor framework positions of the first reference sequence; and b) a second population of oligonucleotides, each encoding i) at least one modified complementarity-determining region, or portion thereof, wherein the modified complementarity-determining region, or portion thereof, comprises a different amino acid at
30 one or more positions when compared to the corresponding donor complementarity-determining region amino acid reference sequence and ii) one or more portions of adjacent framework regions which are capable of hybridizing to the first population of oligonucleotides; and c) mixing the first and second populations of oligonucleotides so as to create overlapping oligonucleotides; and d) extending the overlapping oligonucleotides

with a DNA polymerase under conditions such that a population of altered light chain variable region encoding nucleic acids is constructed.

In some embodiments, one or more modifications are introduced into the framework, simultaneously with the introduction of one or more modified CDRs. The modified CDRs may comprise one or more amino acid alterations in comparison with the
5 corresponding CDR of a reference sequence. In certain embodiments, the methods of constructing a population of altered heavy chain variable region encoding nucleic acids, comprises: a) providing a representation of first and second reference amino acid sequences, the first reference amino acid sequence comprising the sequence of a donor heavy chain
10 variable region, the donor variable region comprising i) framework regions and ii) three complementarity-determining regions as defined by the combined definitions of Kabat and Chothia; the second reference amino acid sequence comprising the sequence of an acceptor heavy chain variable region comprising framework regions; b) synthesizing i) a first population of oligonucleotides, each encoding at least one modified complementarity-
15 determining region, wherein the modified complementarity-determining region comprises a different amino acid at one or more positions when compared to the corresponding donor complementarity-determining region amino acid reference sequence; and ii) a second population of oligonucleotides, comprising oligonucleotides encoding modified portions of a heavy chain variable region framework, the modified portion containing a plurality of
20 changed amino acids at one or more positions when compared to the acceptor framework region reference sequence, wherein the framework positions that are changed are selected from among the acceptor framework positions of the second reference sequence that differ at the corresponding position compared to the donor framework positions of the first reference sequence; c) mixing the first and second populations of oligonucleotides under
25 conditions such that at least a portion of the oligonucleotides hybridize so as to create overlapping oligonucleotides; and d) treating the overlapping oligonucleotides under conditions such that a population of altered heavy chain variable region encoding nucleic acids is constructed. In certain embodiments, the representation of first and second reference sequences is in electronic form. In further embodiments, the methods further
30 comprise the step of (e) coexpressing the population of altered heavy chain variable region encoding nucleic acids with a light chain variable region encoding nucleic acid so as to produce a diverse population of altered heteromeric variable regions. In other embodiments, the acceptor is human.

In other embodiments, the present invention provides methods constructing a population of altered light chain variable region encoding nucleic acids, comprising: a) providing a representation of first and second reference amino acid sequences, the first reference amino acid sequence comprising the sequence of a donor light chain variable region, the donor variable region comprising i) framework regions and ii) three complementarity-determining regions as defined by the combined definitions of Kabat and Chothia; the second reference amino acid sequence comprising the sequence of an acceptor light chain variable region comprising framework regions; b) synthesizing i) a first population of oligonucleotides, each encoding at least one modified complementarity-determining region, wherein the modified complementarity-determining region comprises a different amino acid at one or more positions when compared to the corresponding donor complementarity-determining region amino acid reference sequence; and ii) a second population of oligonucleotides, comprising oligonucleotides encoding modified portions of a light chain variable region framework, the modified portion containing a plurality of changed amino acids at one or more positions when compared to the acceptor framework region reference sequence, wherein the framework positions that are changed are selected from among the acceptor framework positions of the second reference sequence that differ at the corresponding position compared to the donor framework positions of the first reference sequence; c) mixing the first and second populations of oligonucleotides under conditions such that at least a portion of the oligonucleotides hybridize so as to create overlapping oligonucleotides; and d) treating the overlapping oligonucleotides under conditions such that a population of altered light chain variable region encoding nucleic acids is constructed.

In certain embodiments, the antibodies or antibody fragments comprising an Fc variant and an altered heavy chain variant region may be generated. For example, in some embodiments, the present invention provides methods of constructing a population of altered heavy chain variable region encoding nucleic acids, comprising: a) providing a representation of first and second reference amino acid sequences, the first reference sequence comprising the sequence of a donor heavy chain variable region, the donor variable region comprising i) framework regions and ii) three complementarity-determining regions as defined by the combined definitions of Kabat and Chothia; the second reference sequence comprising the sequence of an acceptor heavy chain variable region comprising framework regions; b) synthesizing A) first oligonucleotides encoding portions of the framework regions of the acceptor heavy chain variable region, wherein the portions of the

framework regions when compared to the second reference sequence are unmodified; and B) a population of second oligonucleotides, each encoding i) at least a portion of a first complementarity-determining region that has been modified, the first complementarity-determining region selected from the group consisting of HCDR1, HCDR2 and HCDR3, wherein the modified first complementarity-determining region comprises a different amino acid at one or more positions when compared to the corresponding donor complementarity determining regions of the first reference sequence and ii) one or more portions of unmodified framework regions which are capable of hybridizing to the first oligonucleotides; c) mixing the first oligonucleotides with the population of second oligonucleotides as to create overlapping oligonucleotides; and d) treating the overlapping oligonucleotides under conditions such that a population of altered heavy chain variable region encoding nucleic acids is constructed, wherein the framework regions encoded by the altered heavy chain variable region encoding nucleic acids are unmodified with respect to the second reference sequence. In some embodiments, the methods further comprise the step of (E) coexpressing the population of altered heavy chain variable region encoding nucleic acids with a light chain variable region encoding nucleic acid so as to produce a diverse population of altered heteromeric variable regions.

In other embodiments, the present invention provides methods of constructing a population of altered light chain variable region encoding nucleic acids, comprising: a) providing a representation of first and second reference amino acid sequences, the first reference sequence comprising the sequence of a donor light chain variable region, the donor variable region comprising i) framework regions and ii) three complementarity-determining regions as defined by the combined definitions of Kabat and Chothia; the second reference sequence comprising the sequence of an acceptor light chain variable region comprising framework regions; b) synthesizing a) first oligonucleotides encoding portions of the framework regions of the acceptor light chain variable region, wherein the portions of the framework regions when compared to the second reference sequence are unmodified; and b) a population of second oligonucleotides, each encoding i) at least a portion of a first complementarity-determining region that has been modified, the first complementarity-determining region selected from the group consisting of LCDR1, LCDR2 and LCDR3, wherein the modified first complementarity-determining region comprises a different amino acid at one or more positions when compared to the corresponding donor complementarity determining regions of the first reference sequence and ii) one or more portions of unmodified framework regions which are capable of hybridizing to the first

oligonucleotides; c) mixing the first oligonucleotides with the population of second oligonucleotides as to create overlapping oligonucleotides; and d) treating the overlapping oligonucleotides under conditions such that a population of altered light chain variable region encoding nucleic acids is constructed, wherein the framework regions encoded by the altered light chain variable region encoding nucleic acids are unmodified with respect to the second reference sequence.

In other embodiments, the present invention provides methods of constructing a population of altered heavy chain variable region encoding nucleic acids, comprising: A) providing a representation of first and second reference amino acid sequences, the first reference sequence comprising the sequence of a donor heavy chain variable region, the donor variable region comprising i) framework regions and ii) three complementarity-determining regions as defined by the combined definitions of Kabat and Chothia; the second reference sequence comprising the sequence of an acceptor heavy chain variable region comprising framework regions; B) synthesizing a) a population of first oligonucleotides, each encoding at least a portion of a first complementarity-determining region selected from the group consisting of HCDR1, HCDR2 and HCDR3, wherein the modified first complementarity-determining region comprises a different amino acid at one or more positions when compared to the corresponding donor complementarity determining regions of the first reference sequence; and b) second oligonucleotides encoding i) portions of the framework regions of the acceptor heavy chain variable region, wherein the portions of the framework regions when compared to the reference sequence are unmodified and ii) one or more portions of a complementarity determining region which are capable of hybridizing to the population of first oligonucleotides; C) mixing the population of first oligonucleotides with the second oligonucleotides as to create overlapping oligonucleotides; and D) treating the overlapping oligonucleotides under conditions such that a population of altered heavy chain variable region encoding nucleic acids is constructed, wherein the framework regions encoded by the altered heavy chain variable region encoding nucleic acids are unmodified with respect to the second reference sequence. In certain embodiments, the methods further comprise the step of (E) coexpressing the population of altered heavy chain variable region encoding nucleic acids with a light chain variable region encoding nucleic acid so as to produce a diverse population of altered heteromeric variable regions.

In other embodiments, the present invention provides methods of constructing a population of altered light chain variable region encoding nucleic acids, comprising: A)

providing a representation of first and second reference amino acid sequences, the first reference sequence comprising the sequence of a donor light chain variable region, the donor variable region comprising i) framework regions and ii) three complementarity-determining regions as defined by the combined definitions of Kabat and Chothia; the
5 second reference sequence comprising the sequence of an acceptor light chain variable region comprising framework regions; B) synthesizing a) a population of first oligonucleotides, each encoding at least a portion of a first complementarity-determining region selected from the group consisting of LCDR1, LCDR2 and LCDR3, wherein the modified first complementarity-determining region comprises a different amino acid at one
10 or more positions when compared to the corresponding donor complementarity determining regions of the first reference sequence; and b) second oligonucleotides encoding i) portions of the framework regions of the acceptor light chain variable region, wherein the portions of the framework regions when compared to the reference sequence are unmodified and ii) one or more portions of a complementarity determining region which are capable of hybridizing
15 to the population of first oligonucleotides; C) mixing the population of first oligonucleotides with the second oligonucleotides as to create overlapping oligonucleotides; and D) treating the overlapping oligonucleotides under conditions such that a population of altered light chain variable region encoding nucleic acids is constructed, wherein the framework regions encoded by the altered light chain variable region encoding nucleic acids are unmodified
20 with respect to the second reference sequence.

In other embodiments, the present invention provides methods of improving the binding affinity of a mutated humanized antibody variable region, comprising: a) providing a nucleic acid sequence encoding a first mutated humanized antibody variable region, the mutated variable region comprising (i) a wild type human antibody framework, (ii) three
25 non-human heavy chain complementarity determining regions, and (iii) three non-human light chain complementarity determining regions, wherein the complementarity determining regions are defined by the combined definitions of Kabat and Chothia, wherein at least one of the light chain complementarity determining regions is a mutation-containing light chain complementarity determining region comprising at least one different amino acid at at least
30 one position when compared to the corresponding wild type non-human complementarity determining region, and wherein the first mutated antibody variable region has a higher binding affinity than the corresponding non-mutated antibody variable region; b) mutating the nucleic acid sequence encoding the first mutated antibody variable region under conditions such that a second mutated humanized antibody variable region is encoded, the

second mutated humanized antibody variable region comprising at least one additional different amino acid at least one position in the mutation-containing light chain complementarity determining region, the additional mutation in combination with the first mutation resulting in higher binding affinity. In some embodiments, the mutation-
5 containing light chain complementarity determining region of the first mutated humanized antibody variable region is complementarity determining region 3 (LCDR3). In certain embodiments, the position of the different amino acid in LCDR3 is position 96. In some embodiments, the additional different amino acid is at position 94 of LCDR3. In other
10 embodiments, at least one of the non-human heavy chain complementarity determining regions of the first mutated humanized antibody variable region comprises a mutation, such that a different amino acid is encoded at at least one position when compared to the corresponding wild type non-human complementarity determining region. In additional embodiments, the heavy chain complementarity determining region mutation is in HCDR3.

In some embodiments, the present invention provides methods of of simultaneously
15 modifying at least one complementarity-determining region (CDR) and at least one framework region (FR) while constructing a population of altered heavy chain variable region encoding nucleic acids, comprising: a) providing a representation of first and second reference amino acid sequences, the first reference amino acid sequence comprising the sequence of a donor heavy chain variable region, the donor variable region comprising i)
20 four framework regions and ii) three complementarity-determining regions as defined by the combined definitions of Kabat and Chothia; the second reference amino acid sequence comprising the sequence of an acceptor heavy chain variable region comprising four framework regions, as defined by the combined definitions of Kabat and Chothia; b)
synthesizing i) for every framework region to be modified, a population of oligonucleotides,
25 each encoding a modified framework region, or portion thereof, the modified framework region, or portion thereof, containing a plurality of changed amino acids at one or more positions when compared to the corresponding framework region in the acceptor heavy chain variable region reference sequence, wherein the framework region positions that are changed are selected from among the acceptor framework positions of the second reference
30 sequence that differ at the corresponding position compared to the donor framework region positions of the first reference sequence; and ii) for every complementarity-determining region to be modified, a population of oligonucleotides, each encoding a modified complementarity-determining region, or portion thereof, wherein the modified complementarity-determining region comprises a different amino acid at one or more

positions when compared to the corresponding donor complementarity-determining region amino acid reference sequence; and iii) for each of any remaining and unmodified framework regions, oligonucleotides encoding the framework region, or portion thereof, having the same sequence as the corresponding framework region of the second reference acceptor sequence; and iv) for each of any remaining and unmodified complementarity-determining regions, oligonucleotides encoding the complementarity-determining region, or portion thereof, having the same sequence as the corresponding complementarity-determining region of the first reference donor sequence, wherein, individual oligonucleotides from (i) through (iv) which encode adjacent portions of the heavy chain variable region have overlapping sequences at their termini; and c) mixing the oligonucleotides and populations of oligonucleotides synthesized in step b) under conditions such that the overlapping sequences of individual oligonucleotides hybridize so as to create overlapping oligonucleotides; and d) treating the overlapping oligonucleotides under conditions such that a population of altered heavy chain variable region encoding nucleotides is formed. In certain embodiments, the representation of first and second reference sequences is in electronic form. In further embodiments, the framework region to be modified is selected from the group consisting of HFR1, HFR2 and HFR3. In other embodiments, the complementarity-determining region to be modified is HCDR3. In other embodiments, the method further comprises the step of e) coexpressing the population of heavy chain variable region encoding nucleic acids with a light chain variable region encoding nucleic acid so as to produce a diverse population of altered heteromeric variable regions. In different embodiments, the method further comprises the step of e) coexpressing the population of heavy chain variable region encoding nucleic acids with a population of light chain variable region encoding nucleic acids so as to produce a diverse population of altered heteromeric variable regions.

In other embodiments, the methods of simultaneously modifying at least one complementarity-determining region (CDR) and at least one framework region (FR) while constructing a population of altered light chain variable region encoding nucleic acids are employed, wherein said method comprises: a) providing a representation of first and second reference amino acid sequences, the first reference amino acid sequence comprising the sequence of a donor light chain variable region, the donor variable region comprising i) four framework regions and ii) three complementarity-determining regions as defined by the combined definitions of Kabat and Chothia; the second reference amino acid sequence comprising the sequence of an acceptor light chain variable region comprising four

framework regions, as defined by the combined definitions of Kabat and Chothia; b) synthesizing i) for every framework region to be modified, a population of oligonucleotides, each encoding a modified framework region, or portion thereof, the modified framework region, or portion thereof, containing a plurality of changed amino acids at one or more positions when compared to the corresponding framework region in the acceptor light chain variable region reference sequence, wherein the framework region positions that are changed are selected from among the acceptor framework positions of the second reference sequence that differ at the corresponding position compared to the donor framework region positions of the first reference sequence; and ii) for every complementarity-determining region to be modified, a population of oligonucleotides, each encoding a modified complementarity-determining region, or portion thereof, wherein the modified complementarity-determining region comprises a different amino acid at one or more positions when compared to the corresponding donor complementarity-determining region amino acid reference sequence; and iii) for each of any remaining and unmodified framework regions, oligonucleotides encoding the framework region, or portion thereof, having the same sequence as the corresponding framework region of the second reference acceptor sequence; and iv) for each of any remaining and unmodified complementarity-determining regions, oligonucleotides encoding the complementarity-determining region, or portion thereof, having the same sequence as the corresponding complementarity-determining region of the first reference donor sequence, wherein, individual oligonucleotides from (i) through (iv) which encode adjacent portions of the light chain variable region have overlapping sequences at their termini, and c) mixing the oligonucleotides and populations of oligonucleotides synthesized in step b) under conditions such that the overlapping sequences of individual oligonucleotides hybridize so as to create overlapping oligonucleotides; and d) treating the overlapping oligonucleotides under conditions such that a population of altered light chain variable region encoding nucleotides is formed. In certain embodiments, the methods further comprise the step of e) coexpressing the population of light chain variable region encoding nucleic acids with a population of heavy chain variable region encoding nucleic acids so as to produce a diverse population of altered heteromeric variable regions.

(v) Multispecific antibodies

The present invention provides multispecific antibodies comprising a variant Fc region. Multispecific antibodies have binding specificities for at least two different

antigens. While such molecules normally will only bind two antigens (i.e. bispecific antibodies, BsAbs), antibodies with additional specificities such as trispecific antibodies are encompassed by this expression when used herein. Examples of BsAbs include, but are not limited to, those with one arm directed against a tumor cell antigen and the other arm

5 directed against a cytotoxic trigger molecule such as anti-FcγRI/anti-CD15, anti-p185HER2/FcγRIII (CD16), anti-CD3/anti-malignant B-cell (1D10), anti-CD3/anti-p185HER2, anti-CD3/anti-p97, anti-CD3/anti-renal cell carcinoma, anti-CD3/anti-OVCAR-3, antiCD3/L-D1 (anti-colon carcinoma), anti-CD3/anti-melanocyte stimulating hormone analog, anti EGF receptor/anti-CD3, anti-CD3/anti-CAMA1, anti-CD3/anti-CD19,

10 anti-CD3/MoV18, anti-neural cell adhesion molecule (NCAM)/anti-CD3, anti-folate binding protein (FBP)/anti-CD3, anti-pan carcinoma associated antigen (AMOC-31)/anti-CD3; BsAbs with one arm which binds specifically to a tumor antigen and one arm which binds to a toxin such as anti-saporin/anti-id-1, antiCD22/anti-saporin, anti-CD7/anti-saporin, anti-CD38/anti-saporin, anti-CEA/anti-ricin A chain, antiinterferon-α (IFN-α)/anti-

15 hybridoma idiotype, anti-CEA/anti-vinca alkaloid; BsAbs for converting enzyme activated prodrugs such as anti-CD30/anti-alkaline phosphatase (which catalyzes conversion of mitomycin phosphate prodrug to mitomycin alcohol); BsAbs which can be used as fibrinolytic agents such as anti-fibrin/anti-tissue plasminogen activator (tPA), anti-fibrin/antiurokinase-type plasminogen activator (uPA); BsAbs for targeting immune

20 complexes to cell surface receptors such as anti-low density lipoprotein (LDL)/anti-Fc receptor (e.g. FcγRI, FcγRII or FcγRIII); BsAbs for use in therapy of infectious diseases such as anti-CD3/anti-herpes simplex virus (HSV), anti-T-cell receptor: CD3 complex/anti-influenza, anti-FcγR/anti-HIV; BsAbs for tumor detection in vitro or in vivo such as anti-CEA/anti-EOTUBE, anti-CEA/anti-DPTA, anti-p185HER2/anti-hapten; BsAbs as vaccine

25 adjuvants; and BsAbs as diagnostic tools such as antirabbit IgG/anti-ferritin, anti-horse radish peroxidase (HRP)/anti-hormone, anti-somatostatin/antisubstance P, anti-HRP/anti-FITC, anti-CEA/anti-p-galactosidase. Examples of trispecific antibodies include, but are not limited to, anti-CD3/anti-CD4/anti-CD37, anti-CD3/anti-CD5/anti-CD37 and anti-CD3/anti CD8/anti-CD37. Bispecific antibodies can be prepared as full length antibodies or

30 antibody fragments (e.g. F (ab')₂ bispecific antibodies).

Methods for making bispecific antibodies are known in the art. Traditional production of full length bispecific antibodies is based on the coexpression of two immunoglobulin heavy chain-light chain pairs, where the two chains have different specificities (e.g., Millstein et al, Nature, 305: 537-539 (1983), herein incorporated by

reference). Because of the random assortment of immunoglobulin heavy and light chains, these hybridomas (quadromas) produce a potential mixture of 10 different antibody molecules, of which only one has the correct bispecific structure. Purification of the correct molecule may be performed by affinity chromatography steps. Similar procedures are disclosed in WO 93/08829, and in Traunecker et al., EMBO J., 10: 3655-3659 (1991), both of which are hereby incorporated by reference.

In another approach, antibody variable domains with the desired binding specificities (antibody-antigen combining sites) are fused to immunoglobulin constant domain sequences. The fusion preferably is with an immunoglobulin heavy chain constant domain, comprising at least part of the hinge, CH2, and CH3 regions. It is preferred to have the first heavy-chain constant region (CH1) containing the site necessary for light chain binding, present in at least one of the fusions. DNAs encoding the immunoglobulin heavy chain fusions and, if desired, the immunoglobulin light chain, are inserted into separate expression vectors, and are co-transfected into a suitable host organism. This provides for great flexibility in adjusting the mutual proportions of the three polypeptide fragments in embodiments when unequal ratios of the three polypeptide chains used in the construction provide the optimum yields. It is, however, possible to insert the coding sequences for two or all three polypeptide chains in one expression vector when the expression of at least two polypeptide chains in equal ratios results in high yields or when the ratios are of no particular significance. In a preferred embodiment of this approach, the bispecific antibodies are composed of a hybrid immunoglobulin heavy chain with a first binding specificity in one arm, and a hybrid immunoglobulin heavy chain-light chain pair (providing a second binding specificity) in the other arm (see, e.g., WO 94/04690, herein incorporated by reference). According to another approach described in W096/27011 (hereby incorporated by reference), the interface between a pair of antibody molecules can be engineered to maximize the percentage of heterodimers which are recovered from recombinant cell culture. Bispecific antibodies also include cross-linked or "heteroconjugate" antibodies. For example, one of the antibodies in the heteroconjugate can be coupled to avidin, the other to biotin.

30

B. Immunoadhesin Molecules

The present invention also provides immunoadhesin molecules comprising a variant Fc region. One type of immunoadhesin design combines the binding domain(s) of the adhesin (e.g. the extracellular domain (ECD) of a receptor) with the Fc region of an

immunoglobulin heavy chain (e.g., a variant Fc region). Ordinarily, when preparing the immuno adhesins of the present invention, nucleic acid encoding the binding domain of the adhesin will be fused C-terminally to nucleic acid encoding the N-terminus of an immunoglobulin constant domain sequence, however N-terminal fusions are also possible.

5 Typically, in such fusions the encoded chimeric polypeptide will retain at least functionally active hinge, CH2 and CH3 domains of the constant region of an immunoglobulin heavy chain. Fusions are also made to the C-terminus of the Fc portion of a constant domain, or immediately N-terminal to the CH1 of the heavy chain or the corresponding region of the light chain. The precise site at which the fusion is made is not
10 critical; particular sites are well known and may be selected in order to optimize the biological activity, secretion, or binding characteristics of the immuno adhesin.

In some embodiments, the adhesin sequence is fused to the N-terminus of the variant Fc region of immunoglobulin G₁. It is possible to fuse the entire heavy chain constant region to the adhesin sequence. However, in preferred embodiments, a sequence beginning
15 in the hinge region just upstream of the papain cleavage site which defines IgG Fc chemically (i.e. residue 216, taking the first residue of heavy chain constant region to be 114), or analogous sites of other immunoglobulins is used in the fusion. In certain preferred embodiments, the adhesin amino acid sequence is fused to (a) the hinge region and CH2 and CH3 or (b) the CH1, hinge, CH2 and CH3 domains, of an IgG heavy chain. In some
20 embodiments, the immuno adhesins are bispecific.

Alternatively, the adhesin sequences can be inserted between immunoglobulin heavy chain and light chain sequences, such that an immunoglobulin comprising a chimeric heavy chain is obtained. In such embodiments, the adhesin sequences may be fused to the 3' end of an immunoglobulin heavy chain in each arm of an immunoglobulin, either between the
25 hinge and the CH2 domain, or between the CH2 and CH3 domains (see, e.g., Hoogenboom, et al., Mol. Immunol. 28:1027-1037 (1991), herein incorporated by reference).

Although the presence of an immunoglobulin light chain is not required in the immuno adhesins of the present invention, an immunoglobulin light chain might be present either covalently associated to an adhesin-immunoglobulin heavy chain fusion polypeptide, or directly fused to the adhesin. In the former case, DNA encoding an immunoglobulin
30 light chain is typically coexpressed with the DNA encoding the adhesin-immunoglobulin heavy chain fusion protein. Upon secretion, the hybrid heavy chain and the light chain will be covalently associated to provide an immunoglobulin-like structure comprising two disulfide-linked immunoglobulin heavy chain-light chain pairs. Methods suitable for the

preparation of such structures are, for example, disclosed in U. S. Patent No. 4,816,567, herein incorporated by reference.

In preferred embodiments, immunoadhesins are constructed by fusing the cDNA sequence encoding the adhesin portion in-frame to an immunoglobulin cDNA sequence.

5 However, fusion to genomic immunoglobulin fragments can also be used. Generally, the latter type of fusion requires the presence of Ig regulatory sequences for expression. cDNAs encoding IgG heavy chain constant regions can be isolated based on published sequences from cDNA libraries derived from spleen or peripheral blood lymphocytes, by hybridization or by polymerase chain reaction (PCR) techniques. The cDNAs encoding the
10 "adhesin" and the immunoglobulin parts of the immunoadhesin may be inserted in tandem into a plasmid vector that directs efficient expression in the chosen host cells.

VI. Nucleic Sequences Encoding Fc Region Variants

The present invention also provides nucleic acid sequences encoding Fc region
15 variants, as well as compositions, vectors, and host cells comprising nucleic acid sequences encoding Fc region variants. The present invention also provides recombinant methods for producing Fc region variants.

Generally, for recombinant production of variants, nucleic acid encoding the variant is isolated and inserted into a vector. Host cells may be transfected with the vector, thereby
20 allowing the nucleic acid sequence to be amplified, and/or the variant peptide produced. Nucleic acid sequences encoding the peptide variants of the present invention may be isolated and sequenced using conventional procedures (e.g. using oligonucleotide probes that are capable of binding specifically to nucleic acid encoding the variant). Generally, the nucleic acid sequence encoding the variant is operably linked to other elements, such as a
25 signal sequence (e.g. secretory signal sequences), an origin of replication, at least one marker gene, an enhancer, a promoter, or a transcription terminator. In certain embodiments, host cells are stably transfected with nucleic acid encoding a variant to generate a cell line expressing a particular variant. In preferred embodiments, the variants are expressed in CHO, NSO, Sp2/0, PER.C6, or HEK293 cells. Recombinant methods are
30 well known in the art.

Nucleic acid sequences may be mutated such that variant Fc regions may be produced. For example, a nucleic acid sequence encoding a parental Fc region (e.g. SEQ ID NO:36) may be mutated such that at least one amino acid change results when the nucleic acid sequence is expressed. Also, nucleic acid sequences encoding at least a portion of a

parental Fc region may mutated to produce amino acid sequences comprising at least a portion of an Fc region variant. For example, SEQ ID NO:37 may be mutated, such that at least one amino acid sequence results (See, e.g., SEQ ID NO:38, SEQ ID NO:39, SEQ ID NO:40, SEQ ID NO:41, SEQ ID NO:42, SEQ ID NO:43, SEQ ID NO:44, SEQ ID NO:45, 5 SEQ ID NO:46, and SEQ ID NO:47).

In certain embodiments, codon-based synthesis is employed to generate mutated sequences. Examples of codon-based synthesis include, for example, those described in U.S. Patents 5,264,563, 5,523,388 and 5,808,022, all of which are hereby incorporated by reference. Briefly, codon-based synthesis may be performed by sequentially coupling 10 monomers on separate supports to form at least two different tuplets. The coupling may be performed in separate reaction vessels, then mixing the supports from the reaction vessels, and dividing the mixed supports into two or more separate reaction vessels, and repeating the coupling, mixing and dividing steps one or more times in the reaction vessels, ending with a mixing or dividing step. Additionally, the oligonucleotides can be cleaved from the supports.

15

VII. Therapeutic Formulations and Uses

In some embodiments, the present invention provides therapeutic formulations comprising the variants described herein. It is not intended that the present invention be limited by the particular nature of the therapeutic composition. For example, such 20 compositions can include a polypeptide variant (or portion thereof), provided together with physiologically tolerable liquids, gels, solid carriers, diluents, adjuvants and excipients, and combinations thereof (See, e.g, Remington's Pharmaceutical Sciences 16th edition, Osol, A. Ed. (1980), herein incorporated by reference).

In addition, polypeptide variants may be used together with other therapeutic agents, 25 including, but not limited to, salicylates, steroids, immunosuppressants, antibodies or antibiotics. Particular therapeutic agents which may be used with the variants of the present invention include, but are not limited to, the following agents: azobenzene compounds (US Pat. No. 4,312,806, incorporated herein by reference), benzyl-substituted rhodamine derivatives (US Pat. No. 5,216,002, incorporated herein by reference), zinc L-carnosine 30 salts (US Pat. No. 5,238,931, incorporated herein by reference), 3-phenyl-5-carboxypyrazoles and isothiazoles (US Pat. No. 5,294,630, incorporated herein by reference), IL-10 (US Pat. No. 5,368,854, incorporated herein by reference), quinoline leukotriene synthesis inhibitors (US Pat. No. 5,391,555, incorporated herein by reference), 2'-halo-2'-deoxy adenosine (US Pat. No. 5,506,213, incorporated herein by reference),

phenol and benzamide compounds (US Pat. No. 5,552,439, incorporated herein by reference), tributyrin (US Pat. No. 5,569,680, incorporated herein by reference), certain peptides (US Pat. No. 5,756,449, incorporated herein by reference), omega-3 polyunsaturated acids (US Pat. No. 5,792,795, incorporated herein by reference), VLA-4
5 blockers (US Pat. No. 5,932,214, incorporated herein by reference), prednisolone metasulphobenzoate (US Pat. No. 5,834,021, incorporated herein by reference), cytokine restraining agents (US Pat. No. 5,888,969, incorporated herein by reference), and nicotine (US Pat. No. 5,889,028, incorporated herein by reference).

Polypeptide variants may be used together with agents which reduce the viability or
10 proliferative potential of a cell. Agents which reduce the viability or proliferative potential of a cell can function in a variety of ways including, for example, inhibiting DNA synthesis, inhibiting cell division, inducing apoptosis, or inducing non-apoptotic cell killing. Specific examples of cytotoxic and cytostatic agents, include but are not limited to, pokeweed antiviral protein, abrin, ricin, and each of their A chains, doxorubicin, cisplatin, iodine-131,
15 yttrium-90, rhenium-188, bismuth-212, taxol, 5-fluorouracil VP-16, bleomycin, methotrexate, vindesine, adriamycin, vincristine, vinblastine, BCNU, mitomycin and cyclophosphamide and certain cytokines such as TNF- α and TNF- β . Thus, cytotoxic or cytostatic agents can include, for example, radionuclides, chemotherapeutic drugs, proteins, and lectins.

20 Therapeutic compositions may contain, for example, such normally employed additives as binders, fillers, carriers, preservatives, stabilizing agents, emulsifiers, buffers and excipients as, for example, pharmaceutical grades of mannitol, lactose, starch, magnesium stearate, sodium saccharin, cellulose, magnesium carbonate, and the like. These compositions typically contain 1%-95% of active ingredient, preferably 2%-70% active
25 ingredient.

The polypeptide variants of the present invention can also be mixed with diluents or excipients which are compatible and physiologically tolerable. Suitable diluents and excipients are, for example, water, saline, dextrose, glycerol, or the like, and combinations thereof. In addition, if desired, the compositions may contain minor amounts of auxiliary
30 substances such as wetting or emulsifying agents, stabilizing or pH buffering agents.

In some embodiments, the therapeutic compositions of the present invention are prepared either as liquid solutions or suspensions, as sprays, or in solid forms. Oral formulations usually include such normally employed additives such as binders, fillers, carriers, preservatives, stabilizing agents, emulsifiers, buffers and excipients as, for

example, pharmaceutical grades of mannitol, lactose, starch, magnesium stearate, sodium saccharin, cellulose, magnesium carbonate, and the like. These compositions take the form of solutions, suspensions, tablets, pills, capsules, sustained release formulations, or powders, and typically contain 1%-95% of active ingredient, preferably 2%-70%. One
5 example of an oral composition useful for delivering the therapeutic compositions of the present invention is described in US Pat. No. 5,643,602 (incorporated herein by reference).

Additional formulations which are suitable for other modes of administration, such as topical administration, include salves, tinctures, creams, lotions, transdermal patches, and suppositories. For salves and creams, traditional binders, carriers and excipients may
10 include, for example, polyalkylene glycols or triglycerides. One example of a topical delivery method is described in U.S. Pat. No. 5,834,016 (incorporated herein by reference). Other liposomal delivery methods may also be employed (See, e.g., US Pat. Nos. 5,851,548 and 5,711,964, both of which are herein incorporated by reference).

The formulations may also contain more than one active compound as necessary for
15 the particular indication being treated, preferably those with complementary activities that do not adversely affect each other. Such molecules are suitably present in combination in amounts that are effective for the purpose intended.

Sustained-release preparations may also be prepared. Suitable examples of sustained release preparations include semipermeable matrices of solid hydrophobic
20 polymers containing the polypeptide variant, which matrices are in the form of shaped articles, e.g., films, or microcapsule. Examples of sustained-release matrices include, but are not limited to, polyesters, hydrogels (for example, poly (2-hydroxyethyl-methacrylate), or poly (vinylalcohol)), polylactides, copolymers of L-glutamic acid and γ ethyl-L-glutamate, non-degradable ethylene-vinyl acetate, degradable lactic acid-glycolic acid
25 copolymers such as the LUPRON DEPOT (injectable microspheres composed of lactic acid-glycolic acid copolymer and leuprolide acetate), and poly-D- (-)-3-hydroxybutyric acid. While polymers such as ethylene-vinyl acetate and lactic acid-glycolic acid enable release of molecules for over 100 days, certain hydrogels release proteins for shorter time periods.

30 The polypeptide variants of the present invention may be used to treat a subject. Such treatment may be administered to a subject with a disease, or may be administered prophylactically to a subject (e.g. to a subject predisposed to a disease). Example of conditions that may be treated include, but are not limited to, cancer (e.g. where the polypeptide variant binds the HER2 receptor, CD20 or vascular endothelial growth factor

(VEGF)); allergic conditions such as asthma (with an anti-IgE antibody); and LFA-1-mediated disorders (e.g. where the polypeptide variant is an anti-LFA-1 or anti-ICAM-1 antibody) etc.

In preferred embodiments, the variants used to treat subjects comprise antibodies or immunoadhesins. Also in preferred embodiments, the diseases treated are antibody or immunoadhesin responsive diseases. Examples of antibody responsive diseases include diseases and medical conditions such as: lymphoma (shown to be treatable with RITUXAN, an anti-CD20 antibody), infectious disease (shown to be treatable with SYNAGIS, an antibody directed to the F protein of respiratory syncytial virus), kidney transplant (ZENAPAX, an anti-IL-2 receptor antibody, has shown to be helpful), Crohn's disease and rheumatoid arthritis (shown to be treatable with REMICADE, an anti-TNF alpha antibody), breast carcinoma (shown to be treatable with HERCEPTIN, an anti-HER2 antibody), and colon cancer (shown to be treatable with EDRECOLOMAB, an anti-17-1A antibody).

In some embodiments, a polypeptide variant with improved ADCC activity (e.g. the D280H or K290S variant) is employed in the treatment of diseases or disorders where destruction or elimination of tissue or foreign microorganisms is desired. For example, the variant may be used to treat cancer; inflammatory disorders; infections (e.g. bacterial, viral, fungal or yeast infections); and other conditions (such as goiter) where removal of tissue is desired. In other embodiments, the polypeptide variant has diminished ADCC activity (e.g. the 298N, S298V, or S298D variant). Such variants may be used to treat diseases or disorders where a Fc region-containing polypeptide with long half-life is desired, but the polypeptide preferably does not have undesirable effector function(s). For example, the Fc region-containing polypeptide may be an anti-tissue factor (TF) antibody; anti-IgE antibody; and anti-integrin antibody (e.g. an anti- $\alpha 4\beta 7$ antibody). The desired mechanism of action of such Fc region-containing polypeptides may be to block ligand-receptor binding pairs. Moreover, the Fc-region containing polypeptide with diminished ADCC activity may be an agonist antibody.

The polypeptide variants of the present invention may be administered by any suitable means, including parenteral, subcutaneous, topical, intraperitoneal, intrapulmonary, and intranasal, and, intralesional administration (e.g. for local immunosuppressive treatment). Parenteral infusions include intramuscular, intravenous, intraarterial, intraperitoneal, or subcutaneous administration. In addition, the polypeptide variant is suitably administered by pulse infusion, particularly with declining doses of the polypeptide

variant. Preferably, the dosing is given by injections, most preferably intravenous or subcutaneous injections, depending in part on whether the administration is brief or chronic.

For the prevention or treatment of disease, the appropriate dosage of polypeptide variant will depend on the type of disease to be treated, the severity and course of the disease, whether the polypeptide variant is administered for preventive or therapeutic purposes, previous therapy, the patient's clinical history and response to the polypeptide variant, and the discretion of the attending physician. The polypeptide variant is suitably administered to the patient at one time or over a series of treatments.

For example, depending on the type and severity of the disease, about 1 ug/kg to 15 mg/kg (e.g., 0.120mg/kg) of polypeptide variant is an initial candidate dosage for administration to the patient, whether, for example, by one or more separate administrations, or by continuous infusion. A typical daily dosage might range from about 1 ug/kg to 100 mg/kg or more, depending on the factors mentioned above. For repeated administrations over several days or longer, depending on the condition, the treatment is sustained until the symptoms are sufficiently reduced or eliminated. The progress of this therapy is easily monitored by conventional techniques and assays, and may be used to adjust dosage to achieve a therapeutic effect.

A therapeutically effective amount of a polypeptide variant to be administered is the dosage level required for a patient such that the symptoms of the disease being treated are reduced. The polypeptide variant need not be, but is optionally formulated with one or more agents currently used to prevent or treat the disorder in question. The effective amount of such other agents depends on the amount of polypeptide variant present in the formulation, the type of disorder or treatment, and other factors discussed above.

25 VIII. Additional Variant Fc Region Uses

The variants, and nucleic acid sequences encoding variants, of the present invention may be used in many ways. For example, variants of the present invention may be used in drug screening assays. For example, candidate compounds may be evaluated for their ability to alter or interfere with Fc effector functions by contacting a variant with the candidate compound and determining binding of the candidate compound to the variant. The variant may be immobilized using methods known in the art such as binding a GST-variant fusion protein to a polymeric bead containing glutathione. A chimeric gene encoding a GST fusion protein is constructed by fusing DNA encoding the variant of interest to the DNA encoding the carboxyl terminus of GST (*See e.g., Smith et al., Gene*

67:31 [1988]). The fusion construct is then transformed into a suitable expression system (e.g., *E. coli* XA90) in which the expression of the GST fusion protein can be induced with isopropyl- β -D-thiogalactopyranoside (IPTG). Induction with IPTG should yield the fusion protein as a major constituent of soluble, cellular proteins. The fusion proteins can be
5 purified by methods known to those skilled in the art, including purification by glutathione affinity chromatography. Binding of the candidate compound to the variant is correlated with the ability of the compound to disrupt the one or more effector functions.

In another screening method, either the variant or a selected FcR is immobilized using methods known in the art, such as adsorption onto a plastic microtiter plate or specific
10 binding of a GST-fusion protein to a polymeric bead containing glutathione. For example, GST-variant is bound to glutathione-Sepharose beads. The immobilized variant is then contacted with an Fc receptor and a candidate compound. Unbound peptide is then removed and the complex solubilized and analyzed to determine the amount of bound labeled peptide. A decrease in binding is an indication that the candidate compound inhibits
15 the interaction of variant with the Fc receptor. This screening method is particularly useful with variants of the present invention that show an increased level of Fc receptor binding (e.g. since many parental Fc receptors are low affinity receptors, such as Fc γ RIII, Fc γ RIIb, and Fc γ RIIa). A variation of this method allows for the screening of compounds that are capable of disrupting a previously-formed variant/Fc receptor complex. For example, in
20 some embodiments a complex comprising a variant bound to an Fc receptor is immobilized as described above and contacted with a candidate compound. The dissolution of the complex by the candidate compound correlates with the ability of the compound to disrupt or inhibit the interaction between the variant being tested and the Fc receptor being. In this regard, compounds with therapeutic potential (e.g. in humans) may be identified (e.g.
25 compounds useful in treating human disease, such as autoimmune diseases).

Another technique for drug screening provides high throughput screening for compounds having suitable binding affinity to variant peptides and is described in detail in WO 84/03564, incorporated herein by reference. Briefly, large numbers of different small peptide test compounds are synthesized on a solid substrate, such as plastic pins or some
30 other surface. The peptide test compounds are then reacted with variant peptides and washed. Bound variant peptides are then detected by methods well known in the art.

Another technique uses antibodies directed to variant peptides. Such antibodies capable of specifically binding to variant peptides compete with a test compound for

binding to a given variant. In this manner, the antibodies can be used to detect the presence of any peptide that shares one or more antigenic determinants of the variant peptide.

The present invention contemplates many other means of screening compounds. The examples provided above are presented merely to illustrate a range of techniques
5 available. One of ordinary skill in the art will appreciate that many other screening methods can be used.

In particular, the present invention contemplates the use of cell lines transfected with nucleic acid encoding at least one Fc region variant for screening compounds for activity, and in particular to high throughput screening of compounds from combinatorial libraries
10 (*e.g.*, libraries containing greater than 10^4 compounds). The cell lines of the present invention can be used in a variety of screening methods.

The variants of the present invention may be used as an affinity purification agent. For example, the variant may be immobilized on a solid phase such a Sephadex resin or filter paper, using methods well known in the art. The immobilized variant is then
15 contacted with a sample containing the antigen to be purified, and thereafter the support is washed with a suitable solvent that will remove substantially all the material in the sample except the antigen to be purified, which is bound to the immobilized polypeptide variant. Finally, the support is washed with another suitable solvent, such as glycine buffer, pH 5.0, that will release the antigen from the polypeptide variant.

The polypeptide variant may also be useful in diagnostic assays (*e.g.*, for detecting
20 expression of an antigen of interest in specific cells, tissues, or serum). For diagnostic applications, the variant will typically be labeled with a detectable moiety (such labels are also useful in the Fc region assays described above). Numerous labels are available, including, but not limited to, radioisotopes (*e.g.*, ^{35}S , ^{14}C , ^{125}I , ^3H , and ^{131}I), Fluorescent
25 labels (*e.g.* rare earth chelates (europium chelates) or fluorescein and its derivatives, rhodamine and its derivatives, dansyl, Lissamine, phycoerythrin and Texas Red), and various enzyme-substrate labels (see, *e.g.*, U. S. Patent No. 4,275,149, herein incorporated by reference, and luciferase, luciferin, 2,3-dihydrophthalazinediones, malate dehydrogenase, urease, peroxidase such as horseradish peroxidase (HRPO), alkaline phosphatase, β -
30 galactosidase, glucoamylase, lysozyme, saccharide oxidases (*e.g.*, glucose oxidase, galactose oxidase, and glucose-6-phosphate dehydrogenase), heterocyclic oxidases (such as uricase and xanthine oxidase), lactoperoxidase, microperoxidase, and the like). Examples of enzyme-substrate combinations include, for example: (i) Horseradish peroxidase (HRPO) with hydrogen peroxidase as a substrate, wherein the hydrogen peroxidase oxidizes a dye

precursor (e.g., orthophenylene diamine (OPD) or 3,3', 5,5'-tetramethyl benzidine hydrochloride (TMB)); (ii) alkaline phosphatase (AP) with para-Nitrophenyl phosphate as chromogenic substrate; and (iii) -D-galactosidase (R-D-Gai) with a chromogenic substrate or fluorogenic substrate.

5 The variants of the present invention may also be used for in vivo diagnostic assays. For example, the polypeptide variant is labeled with a radionuclide so that the antigen or cells expressing it can be localized using immunoscintigraphy.

EXPERIMENTAL

10 The following examples are provided in order to demonstrate and further illustrate certain preferred embodiments and aspects of the present invention and are not to be construed as limiting the scope thereof.

 In the experimental disclosure which follows, the following abbreviations apply: N (normal); M (molar); mM (millimolar); μ M (micromolar); mol (moles);
15 mmol (millimoles); μ mol (micromoles); nmol (nanomoles); pmol (picomoles); g (grams); mg (milligrams); μ g (micrograms); ng (nanograms); l or L (liters); ml (milliliters); μ l (microliters); cm (centimeters); mm (millimeters); μ m (micrometers); nm (nanometers); DS (dextran sulfate); and C (degrees Centigrade).

20

EXAMPLE 1

Recombinant IgG and Fc γ R Expression

This example describes the recombinant expression of IgG and Fc γ R.

A. IgG Expression

25 Human genomic sequence encoding the kappa light chain constant region and the γ 1 heavy chain constant region were amplified from human white blood cell genomic DNA by PCR and cloned into an expression plasmid containing either zeocin or neomycin resistance selectable markers. The kappa light chain genomic constant region sequence was amplified with a two step PCR using the following nested primers: Outer 5' primers: 5'-
30 TTCTAAACTCTGAGGGGGTCGG-3' (SEQ ID NO:1), Outer 3' primer: 5'-GTGAGGTGAAAGATGAGCTG-3' (SEQ ID NO:2), Inner 5' primer: 5'-TTCTCCCGGGCGGCCGCCATTCTTTGCCTAAAGCAT-3' (SEQ ID NO:3), and Inner 3' primer: 5'-ATGTCGAATTCAGGCTGGAAGTGGAGCA-3' (SEQ ID NO:4).

Human $\gamma 1$ genomic constant region sequence was similarly amplified using the following primers: Outer 5' primer: 5'-AGCTTTCTGGGGCAGG-3' (SEQ ID NO:5), Outer 3' primer: 5'-GGTGCTTTATTTCCATGCTG-3' (SEQ ID NO:6), Inner 5'-primer: 5' TTCTCCCGGGCGGCCGCTGACCTTGGCTTTGGGGCA-3' (SEQ ID NO:7), Inner 3'-
5 primer: 5'-ATGTCGAATTCATCCTCGTGCGACCGCGAGA-3' (SEQ ID NO:8).

Human genomic leader sequences, including the leader intron, were synthesized by PCR amplification of overlapping oligonucleotides. The light chain leader was modeled after a human Vk III sequence (See, Klobeck et al., *Nucleic Acids Research*, 25, 13(18):6499-513 (1985)). The final kappa light chain leader sequences was: 5'-
10 ATCAGCAAGCTTACCCAGAGGAACCATGGGAAACCCAGCGCAGCTTCTCTT
CCTCCTGCTACTCTGGCTCCCAGGTGAGGGGAACATGGGATGGTTTTGCATGT
CAGTGAAAACCCTCTCAAGTCCTGTTGCCTGGCACTCTGCTCAGTCAATACAA
TAATTAAGCTCAATATAAAGCATTAAATTCAGACTCTTCTGGGAAGACAATG
GGTTTCATCTAGA-3' (SEQ ID NO:9).

15 The $\gamma 1$ heavy chain leader was modeled after a human VHIII sequence (See, Berman et al., *EMBO J.*, 7(3):727-38 (1988)). The final $\gamma 1$ heavy chain leader sequence was 5'-
ATCAGCAAGCTTGAGGACTCACCATGGAGTTTGGGCTGAGCTGGGTTTTCTT
GTTGTTATTTACAAGGTGATTTATGGAGAAGTAGAGATGTTAAGTGTGAGTG
20 GAGGTGACTGAGAGAAACAGTGGGTATGTGTGACAGTTTCTAGACCACTT-3'
(SEQ ID NO:10). Both leader sequences were flanked by upstream HindIII restriction sites and downstream XbaI restriction sites.

Variable region sequences derived from an anti-prostate-specific antigen (PSA) monoclonal antibody were amplified by PCR and cloned in each heavy and light chain
25 parental vector. Briefly, PCR primers were designed to contain intervening DNA sequence and a short segment of the leader sequence flanking the variable region and a splice donor and restriction site at the 5'-end. The light chain variable region was amplified with the following primers: 5'-
TTGCTCTAGATTACATGGTTGACTTTTCTGTTTTATTTCCAATCTCAGATACCA
30 CCGGAGACATTGTGTTGACCCAGTCT-3' (SEQ ID NO:11), and 5'-
TACAAGCGGCCGCTGACAGATGTACTTACGTTTTATTTCCAACCTTTGTCCC-3'
(SEQ ID NO:12). The heavy chain variable region was amplified with the following primers: 5'-AGTTTCTAGACCAGGGTGTCTCTGTCTCTGTGTTTGCAGGTGTCCAG

TGTCAGGTCCAACACTGCAGCAG-3' (SEQ ID NO:13), and 5'-
ACAAGCGGCCGCAGGGGGTGGTGAGGACTCACCTGAGGAGACGGTGACTGAG-
3' (SEQ ID NO:14). Following PCR, these products were purified and digested with NotI
and XbaI restriction endonucleases and the cleaved fragments ligated into similarly digested
5 vectors. Positive clones were confirmed by DNA sequencing.

Two micrograms of a mixture of each heavy and light-chain vector were con-
transfected into human 293 cells using Polyfect transfection reagent (Qiagen Inc., Valencia,
CA) following the manufacturer's protocol. Transient IgG expression levels were optimized
by varying the relative amount of the heavy and light-chain vectors from 1:3 to 3:1 in the
10 transfection process. An optimized heavy:light chain stoichiometry of 1:3 was utilized for
all subsequent transient transfections. Following incubation of the DNA and the
transfection reagent, about 500,000 cells per well were grown in 3.0 mL Dulbeccos
Modified Eagle media (DMEM), supplemented with 1mM L-glutamine, 10% fetal calf
serum and non-essential amino acids at 37 degrees Celsius in a 5% CO₂ incubator. Cell
15 culture supernatants containing secreted IgG were collected each day following transfection
and the expression level quantitated as described below. This time course revealed that the
IgG expression level increased linearly as a function of time for at least one week following
transfection. For screening purposes supernatants were generally collected four to six days
following transfection, centrifuged briefly and stored at 4 degrees Celsius prior to assay.
20 Cell culture supernatants stored in this manner for at least 2 months gave essentially
identical values in a quantitation assay.

Quantitation of IgG expression was performed as follows. Antibody concentration
was estimated by enzyme-linked immunosorbent assay (ELISA). Microtiter plates were
coated with 5 ug/mL goat anti-human K antibody (Southern Biotechnology Associates, Inc.
25 Birmingham, AL) diluted in carbonate coating buffer (15 mM Na₂CO₃-H₂O, 35 mM
NaHCO₃, pH 9.3) and blocked with 1% bovine serum albumin (BSA) in phosphate
buffered saline (PBS). Transfected 293 cells culture supernatants were diluted 50-fold in
PBS and two-fold serial dilutions added to the assay wells and incubated for 1 hour at 25
degrees Celsius. The plate was washed 3 times with phosphate buffered saline, 0.1%
30 Tween-20, pH 7.0 (PBST) and 100 uL NeutraAvidin alkaline phosphatase conjugate (Pierce
Chemical Co, Rockford IL) diluted 1:1000 in PBS was added and incubated at 25 degrees
Celsius for 30 minutes. Microtiter plates were washed three times with PBST and
following addition of a 1:24 dilution of the phosphatase substrate (phenolphthalein
monophosphate) (PPMP) (JBL Scientific) in water, antibody concentration determined

colorimetrically at 560 nm with a VMAX microplate reader (Molecular Devices, Sunnyvale, CA). Concentrations were calculated by comparison to a standard curve fit to a polynomial equation of the form $y=A+Bx+Cx^2$ using the microplate reader software.

Transient expression levels in the range of 0.5 to 5.0 ug/mL were obtained for the different

5 Fc-region IgG variants.

Antigen capture of IgG for concentration normalization was performed as follows.

Immulon 2 (Dynex Technologies) microtiter assay plates were coated with PSA

(Biospecific, Emeryville, CA) at a concentration of 1-2 ug/ml in carbonate coating buffer

for 1 hour at 25 degrees Celsius. Alternatively, plates were coated with PSA overnight at 4

10 degrees Celsius. Following PSA coating unoccupied binding sites were blocked with 200

uL of a blocking agent such as BSA or Superblock (Pierce Chemical Co., Rockford Ill) for

up to 1 hour at 25 degrees Celsius. Superblock was shown to give a lower background

signal than BSA, and was used for all subsequent receptor binding ELISA assays. Blocked

plates were washed 3 times with PBST followed by incubation with anti-PSA IgG

15 containing cells culture supernatants diluted three-fold in PBS for 1 hour at 25 degrees

Celsius with gentle shaking. Ten-fold dilutions of the wild-type anti-PSA IgG cell culture

supernatants gave essentially identical amplitude and apparent Kd values when the receptor

concentration was varied and the data fit to a standard hyperbolic binding expression.

These results suggest that differences in antibody concentration of within at least 10-fold

20 range can be normalized using this antigen-based capture of IgG variants.

B. Human FcγR Expression

FcγRIIa, FcγRIIb, and FcγRIIa were cloned from a placental cDNA library by PCR and sequenced. Sequence-confirmed full-length receptor encoding DNA were amplified by

25 PCR with primers that truncated each receptor at its putative transmembrane domain.

Forward primers contained an NcoI restriction site located at the 5'-end of the primer.

Reverse primers contained a stop codon followed by a HindIII site located at the 5'-end of

the primer. Following PCR, amplicons were purified and cleaved with NcoI and HindIII

and subcloned into similarly digested expression plasmid Receptor encoding plasmids were

30 transformed into E. coli and plated on LB media containing 50 micrograms/mL ampicillin

and 34 micrograms/mL chloramphenical. Single colonies were picked, inoculated in 50 mL

LB media containing ampicillin and chloramphenical overnight at 37 degrees Celsius.

Overnight cultures were diluted 1:50 into 1 liter scale flasks containing LB media

prewarmed to 37 degrees Celsius and supplemented with ampicillin. Protein expression

was induced at early log phase (OD 600 of 0.3) with isopropylthiogalactoside (IPTG) at a final concentration of 1 mM. Following induction, cells were grown for approximately 4 hours at 37 degrees Celsius with shaking and harvested by centrifugation.

The refolding and purification of soluble human FcγRs was performed as follows
5 (Sondermann, P, et al. Nature 406: 267-273 (2000), herein incorporated by reference).
Briefly, cell pellets from the induced E. coli cultures were lysozyme treated and sonicated on ice. Following lysis the resulting suspension was centrifuged for 30 minutes at 30000 g. Inclusion bodies were washed twice with buffer containing 0.5% N, N-dimethylamine-N-oxide (LDAO) followed by two washings with LDAO. The inclusion bodies were
10 dissolved with 6 M guanidine hydrochloride and renatured by rapid dilution. Protein refolding was monitored using Ellman's reagent, dialyzed, concentrated and applied to a Superdex-75 size exclusion column. Receptor concentrations were determined spectrophotometrically at 280 nm utilizing molar extinction coefficients calculated based upon amino acid composition. The following extinction coefficients: 29,160 cm⁻¹ (M)⁻¹;
15 30,440 cm⁻¹ (M)⁻¹; and 38, 690 cm⁻¹ (M)⁻¹ were utilized for FcγRIIa, FcγRIIb and FcγRIIIa, respectively. Utilizing the E. coli-based expression method, milligram quantities of soluble human FcγR purified to greater than 95% apparent homogeneity can be obtained.

Biotinylation of the FcγRs was done utilizing sulfosuccinimidyl-6-
(biotinamido)hexanoate (NHS, Pierce) in PBS under optimized conditions. Optimization of
20 receptor biotinylation was achieved by varying the molar ration of biotin:protein and by varying the pH. Under optimized conditions, 0.9 mg of each receptor was incubated with 0.4 mg of reactive biotin (20:1 molar dye:protein ration) at pH 6.0 on ice for 2 hours. Following incubation, reactions were quenched by the addition of 1.0 mM ethanolamine. Labeled proteins were separated from unconjugated dye molecules using a 10 mL size
25 exclusion (5000 MW cut off) column. Proteins were eluted from this column using 12.0 mL of PBS, 1 ml fractions were collected and analyzed by SDS-PAGE and OD 280 nm measurements made to calculate concentration. In some cases, unconjugated biotin was removed by dialysis against 4 liters of PBS overnight at 4 degrees Celsius. The effect of biotinylation upon protein binding was determined by coating soluble human FcγR proteins
30 on the assay plate wells followed by antibody titration, typically from 0.1 to 8 micromolar, and anti-human K secondary detection. In this way, the binding curves generated from the biotinylated protein can be directly compared to those generated using non-biotinylated protein enabling optimization of the biotinylation reaction conditions.

EXAMPLE 2

Fc-region Mutagenesis and Screening of Variants

The CH2 domain of IgG beginning at the lower hinge and ending at the CH3 domain is scanned using codon-based mutagenesis one region at a time. A region refers to a
5 contiguous stretch of amino acids of about 6 to 10 amino acids in length, some of which are solvent-exposed and some of which are non-solvent exposed. For each library region a deletion template is constructed which removes the codons of interest and replaces these with a stop codon, creating a non-functional template molecule. A single-stranded uracil containing DNA molecule is then prepared from these deletion templates and used for
10 mutagenesis. Mutagenesis is accomplished by hybridization and extension of synthetic oligonucleotides containing NNK type codon-based randomization where N equals any base and K equals G or T. In this way each amino acid in the Fc-region can be replaced with all 19 other amino acids and the effect of the changes can be measured experimentally. The following example describes the generation of a specific subset of Fc-region variants and
15 screening of these variants in an ELISA assay.

A. Targeted Mutagenesis of α -PSA Fc-region

Fc-region mutant libraries were constructed in a two-step process. In the first step, the region to be mutated was deleted from the heavy chain vector and replaced with a stop
20 codon and an extra base to change the reading frame of this region. This creates a non-functional mutant parental antibody. In the second step, uracil-containing single-stranded DNA is prepared and used as a template for mutagenesis with the synthetic oligonucleotide primers containing the randomized codons.

Focused library mutagenesis was performed in the region from 292-301 [293-
25 REEQYNSTYR-301] (Kabat numbering system) using codon-based synthesis, a process by which synthetic oligonucleotides containing NNK type codon-based randomization (N equals any base and K equals G or T) were synthesized. In this library, the codon for the site of N-linked glycosylation, N297, and an adjacent amino acid position, T299 are preserved to maintain NXS/T glycosylation motif that is known to be required for proper in
30 vivo glycosylation (Gavel et al., Protein Eng 1990 Apr;3(5):433-42). This library was constructed in an α -PSA specific context as described in Example 1.

B. ELISA Screening of Fc-region IgG Variants

IgG variants from this library were screening using an antigen-based capture ELISA. Specifically, following incubation of α -PSA containing media (as described in Example 1) the antigen-coated plates were washed 3 times with PBST to remove unbound IgG, cell
5 debris and media components. Two-fold serial dilutions of soluble human Fc γ R labeled with biotin under optimized conditions were added to the microtiter plate and incubated for 1 hour at 25 degrees Celsius. Following incubation and washing, a 1:1000 dilution of Neutravidin alkaline phosphatase conjugate (NA-AP) in PBST was added following incubation for 1 hour at room temperature. Unbound NA-AP was removed by washing 3
10 times with PBST. Phosphatase substrate diluted 1:24 in water was added to the microplate wells followed by incubation until sufficient color development ($A_{560} \text{ nm} > 0.2$) was achieved. Reactions were stopped by the addition of stop buffer (30 mM Tris, 15 mM EDTA, pH 10.3) and absorbance measured at 560 nm with a VMAX microplate reader. Background absorbance measurements were made from wells processed in the absence of
15 PSA-coating and using an antibody template containing a deletion in the Fc-region. Background absorbance readings were subtracted from the values obtained for each variant. The background subtracted data were plotted as A_{560} versus receptor concentration and fit to a standard hyperbolic binding expression of the form $y=A(X)/(B+X)$. The apparent equilibrium dissociation constant (K_d) is reported as the receptor concentration giving one
20 half maximal binding signal as determined from the saturation point of the binding isotherm. For primary screening single-point ELISA measurements were made at receptor protein concentrations in excess of the K_d values determined with the parental antibody binding to each receptor.

The results for various Fc variants tested are reported below in Tables 3-5. Table 3
25 shows Group I variants that have a Specificity Ratio > 1.0 , and also have a relative Fc γ RIII value > 1.0 . Table 4 shows Group II variants that bind to Fc γ RIII, Fc γ RIIa, and Fc γ RIIb with enhanced affinity. Table 5 shows group III variants that bind to Fc γ RIII and Fc γ RIIb with reduced affinity.

30

TABLE 3

Group I Variants = Specificity Ratio (FcγRIII/FcγRIIb) > 1.0 (also have relative FcγRIII > 1.0)

	Variant	relative FcγRIII	relative FcγRIIb	specificity ratio
5	Y300I	1.38	1.26	1.1
	Y300L	1.81	1.36	1.33
	Q295K	1.47	.892	1.65
	E294N	1.14	.672	1.7
10	S298N	1.42	.363	3.91
	S298V	2.8	.592	4.72
	S298D	2.31	.188	12.29

15

TABLE 4

Group III Variants = Bind to FcγRIII, FcγRIIa, and FcγRIIb with enhanced affinity

	Variant	relative FcγRIII	relative FcγRIIb	relative FcγRIIa
20	Q295L	1.06	1.34	1.44

TABLE 5

Group IV Variants = Bind to FcγRIII and FcγRIIb with reduced affinity

	Variant	relative FcγRIII	relative FcγRIIb
25	S298P	0	0
	Y296P	0	0

30

The values reported are the average of at least triplicate data points and are normalized relative to the parental antibody. For each variant, triplicate data points were averaged and, from this value, was subtracted the average value obtained for a deletion template lacking amino acids 293-301. The background-subtracted averaged data were normalized to the parental antibody by setting its value at 1.0 for each receptor. The specificity is calculated by dividing the normalized FcγRIII binding data by the normalized FcγRIIb binding data.

35

C. Additional Fc Variants

An additional set of Fc variants were also identified from an additional library (e.g. prepared as described above). These variants were screened in a manner similar to above, but the parent IgG was an anti-TNFα (not anti-PSA). The results of this screening are presented below in Table 6.

40

Table 6

	<u>Variant</u>	<u>relative FcγRIII</u>	<u>relative FcγRIIb</u>	<u>specificity ratio</u>
	D280H	1.24	0.92	1.35
	K290S	1.23	1.4	0.87
5	D280Q	1.19	0.87	1.36
	D280Y	1.23	2.14	0.57
	K290G	1.64	1.46	1.12
	K290T	1.43	1.0	1.43
	K290Y	1.3	1.45	0.9

10

EXAMPLE 3**Chinese Hamster Ovary vs 293 cell expressed WT and S298D IgG**

This example describes testing the ability of CHO expressed wild type and S298D variant IgG to bind certain Fc receptors in comparison to the ability of 293 cell expressed wild type and S298D variant IgG to bind the same Fc receptors. Briefly, parental and Fc variant (S298D) heavy chain encoding plasmids were each mixed with light-chain plasmid and the mixture co-transfected into human 293 or CHO cells using Polyfect transfection reagent (Qiagen Inc, Valencia, CA) following the manufacturer's protocol. Cell culture supernatants containing the secreted IgG were collected 1 week following transfection and the protein concentration quantitated. The parental and Fc variant IgGs were assayed for binding to biotinylated FcγRIIb and FcγRIII by a modified ELISA.

Due to the relatively weak affinity of Fc receptor-Fc interaction others have stated that these interactions cannot be reliably measured using an ELISA format. However, it was discovered that the low affinity of this interaction can be overcome by using relatively high concentrations (micromolar range) of labeled receptor protein. In this assay format assay plates are coated with antigen and blocked, followed by incubation of the antigen coated plates with the Fc-region variants. To the antigen-captured variants is added biotin-labeled Fc receptor protein at a concentration of in excess of the K_d value (from 1 to 10 micromolar) for one hour. Assay wells are then quickly washed to minimize dissociation of the receptor protein from the captured IgG variant followed by addition of Neutravidin alkaline phosphatase conjugate. Alternatively the biotinylated receptor proteins can be pre-complexed with a detection reagent such as Neutravidin alkaline phosphatase conjugate. In this case it allows the formation of a multimeric receptor-Neutravidin complex formation which leads to an increase in the avidity of the interaction leading to stronger assay signals.

Briefly, assay plate wells were coated with antigen at a concentration of 1 µg/mL overnight at 4° C and blocked. IgG containing supernatants were each diluted 3-fold in PBS and 100 µL of the diluted samples were added to the antigen coated assay plates and incubated for one hour at room temperature. Following incubation the plates were washed three times
5 with PBST buffer. To the washed plates were added 2-fold serial dilutions of biotinylated FcγRIIb and FcγRIII receptors pre-complexed with Neutravidin alkaline phosphatase conjugate. The precomplexes were formed by mixing 500 nM each receptor with approximately 10 nM Neutravidin alkaline phosphatase conjugate for ten minutes on ice. Following incubation for one hour at room temperature the plates were washed three times.
10 To the washed plates was added phosphatase substrate PMPP followed by incubation at room temperature until sufficient color development was achieved. The absorbance at 560 nM was read using a microplate reader and the absorbance data plotted vs. the dilution factor of the receptor complexes using Sigmaplot. The results are presented in Figures 7 and 8.

15

EXAMPLE 4

Assaying Variants in ADCC Assays

This example describes how certain variants were tested in an ADCC assay. In particular, this example describes how the S298N, S298V, S298D, D280H, and K290S
20 variants were assayed for ADCC activity. All variants tested were converted to anti-CD20 molecules prior to testing.

i. PBMC (peripheral blood mononuclear cell) isolation

About 50 mL of peripheral blood is obtained from a healthy donor and diluted 1:2
25 with phosphate buffered saline (PBS), pH 7.0. The samples are mixed by gently swirling the tube. About 12 mL of Histopaque-1077 (Sigma Cat. No. 1077-1) is carefully layered underneath the diluted sample followed by centrifugation in a Sorvall RT6000B centrifuge with swinging bucket rotor at 1000 rpm for 10 min with the brake turned off. The top phase of the gradient is discarded and the white-colored, PBMC-containing interphase collected
30 and washed 3 times with Hanks' Balanced Salt Solution (Gibco Cat. No. 14025-092). The washed cell pellet is suspended in about 20 mL RPMI 1640 Media (ATCC Cat. No. 30-2001) containing 10% Fetal Bovine Serum (FBS) (Omega Scientific Cat. No. FB-01). The resuspended PBMCs are split into two T-175 culture flasks, 30 mL of RPMI/10%FBS added to each followed by incubation overnight in a 37°C/5%CO₂ incubator. The

following day the nonadherent PBMCs are collected in 50 ml Falcon tubes, centrifuged as above and resuspended in RPMI containing 1% FBS. A small volume of the resuspended cells are diluted 1:10 and counted using a hemocytometer. The remaining PBMCs are placed in the incubator until needed.

5

ii. Target cell line (these are specific for anti-CD20 ADCC assays)

Wil.2 B-cell line were obtained from ATCC and grown as recommended. One day before use, the cells are split 1:2. The next day the concentration is adjusted to 0.5 to 1 X10⁶ cells/mL and 50 uL (25,000 to 50,000 cells/well) aliquots added to a Becton
10 Dickinson 96-well U-bottom tissue culture plate (Cat. No. 353077).

iii. IgG titrations

In general, IgG is titrated in the range from about .0001 to 1 ug/mL. IgG dilutions are prepared using a 96-well microtiter plate by diluting the samples in RPMI containing
15 1% FBS. Fifty microliter aliquots of IgG are added to the target cells and mixed by gentle pipeting. The IgGs are incubated with the target cells for about 15 min at 37°C in the presence of 5% CO₂ prior to adding the effector cells to the assay. The final IgG concentration in the assay will be diluted by 4-fold.

20

iv. Effector cells

One hundred microliters of the resuspended PBMCs are added to each well of the target cell/IgG plate. The concentration of the PBMCs is adjusted so that the effector:target ratio is in the range of 10-20:1 (i.e. 5-10 million/mL). The plates are incubated at 37°C in the presence of 5% CO₂ for 3-4 hours.

25

v. LDH-release detection

Following incubation, the plate is centrifuged at 1-2000 rpm for 5-10 minutes. Fifty uL of the supernatant is carefully removed while the pelleted cells and debris are avoided. This supernatant is added directly to a Dynex Immulon 2HB flat bottom plate containing 50
30 uL of PBS per well. To this plate is added 100 ul of LDH detection reagent (Roche Cat. No. 1 644 793). The plate is then incubated for approximately 15-30 min. and read at 490 nm using a Molecular Devices Vmax Kinetic Microplate Reader.

vi. Results

Result were generated for each of the five variants tested (S298N, S298V, S298D, D280H, and K290S). These results are shown in Figures 9-11. Data are plotted as log IgG concentration vs. A490. A490 can be converted into % cytotoxicity using the following equation: % cytotoxicity = (experimental A490 - basal A490)/(maximal A490 - basal A490) X 100, with maximal A490 determined by adding 2% Triton X-100 to the target cells and basal-release measured for a mixture of effector and target cells in the absence of sensitizing IgG.

The results presented in Figures 9-11 show that three of the variants, S298N, S298N, and S298D had decreased ADCC activity compared to the parent (wild type) polypeptide, while two of the variants, D280H and K290S, gave increased ADCC activity compared to the parent (wild type) polypeptide. These results are surprising as it was thought that the four variants with increased FcγRIII binding activity and decreased FcγRIIb binding activity (i.e. variants S298N, S298V, S298D, and D280H) would likely have increased ADCC activity. These results, however, show that only one of these variants (D280H) had increased ADCC activity compared to the parent. This is even more surprising as D280H had the lowest specificity ratio (1.35) of these four variants. It is also somewhat surprising that K290S was found to have better ADCC activity than the parent even though its FcγRIIb binding activity (1.4) was greater than its FcγRIII binding activity (1.23).

EXAMPLE 5**Anti-CD20-D280H Fc Variant Human Therapy**

In vitro studies and murine tumor models (Clynes RA, et al. Nat Med. 6:443 (2000)) provide evidence that ADCC plays a role in the anti-tumor effects of anti-CD20 antibodies, such as RITUXAN. Human patients may be treated with anti-CD20-D280H Fc variant antibodies (or other anti-CD20 antibodies with variant Fc regions, such as D280A, D280K, D280N, or D280T), or RITUXAN, in a manner similar to that disclosed in Cartron et al., Blood 99:754 (2002), herein incorporated by reference. For example, patients presenting with stage II to IV disease according to the Ann-Arbor classification, having at least one measurable disease site, and low tumor burden according to the GELF criteria, could be treated with a total of four approximately 375 mg/m² doses of an anti-CD20-D280H Fc variant or with RITUXAN administered by intravenous infusion (days 1, 8, 15, and 22). The primary efficacy end point is the objective response rate, ie, the proportion of patients

achieving either complete remission (CR), unconfirmed CR (Cru), or partial response (PR) according to criteria recently proposed by an international expert committee. Clinical response may be evaluated at month two (M2). Patients may also be evaluated for progression at 1 year (M12).

5 The objective response rates at M2 and M12 for patients treated with RITUXAN or anti-CD20-D280H can be compared such that the improved ADCC activities provided by D280H variants may be quantified. This same example could be repeated with K290S anti-CD20 variants (or other variants such as K290D, K290N, K290P, K290T, or K290V).

10

EXAMPLE 6

Screening Variants

This example describes how a number of variants (shown in Table 7 below) were screened in ADCC assays, CDC assays, and FcRn assays. All variants screened were anti-CD20 antibodies (based on variable region specificity).

15

A. ADCC Assays

i. PBMC (peripheral blood mononuclear cell) isolation

About 50 mL of peripheral blood is obtained from a healthy donor and diluted 1:2 with phosphate buffered saline (PBS), pH 7.0. The solutions are mixed by gently swirling
20 the tube. About 12 mL of Histopaque-1077 (Sigma Cat. No. 1077-1) is carefully layered underneath the diluted blood sample followed by centrifugation in a Sorvall RT6000B centrifuge with swinging bucket rotor at 1000 rpm for 10 minutes with the brake turned off. The upper phase of the gradient is discarded by aspiration and the white-colored, PBMC-containing interphase collected and washed 3 times with Hanks' Balanced Salt Solution
25 (Gibco Cat. No. 14025-092). The washed cell pellet is suspended in about 20 mL RPMI 1640 media containing 10% Fetal Bovine Serum (FBS) (Omega Scientific Cat. No. FB-01). The resuspended PBMCs are split into two T-175 culture flasks, and 30 mL of RPMI containing 10% FBS is added to each followed by incubation overnight in a 37°C 5% CO₂ incubator. The following day the nonadherent PBMCs are collected in 50 mL Falcon tubes,
30 centrifuged as above and resuspended in RPMI containing 1% FBS lacking phenol red. A small portion of the resuspended cells are diluted 10-fold and counted using a hemocytometer. The remaining PBMCs are placed in the incubator until needed.

ii. *Target cell line (these are specific for anti-CD20 ADCC assays)*

Wil.2 and SKW6.4 CD20-expressing B-cell lines were obtained from ATCC and grown as recommended. One day before use, the cells are split 2-fold. The next day the cell number is adjusted to 4×10^5 cells/mL and 50 μ L aliquots (20,000 cells/well) added to a 96-well tissue culture plate.

iii. *IgG dilutions*

Prior to screening, IgG variants are expressed and quantitated using a standard enzyme-linked immunosorbent assay (ELISA). For primary single-point ADCC screening IgG variants are diluted to 40 ng/mL in RPMI media containing 1% FBS lacking phenol red. The final IgG concentration in the assay will be diluted by 4-fold (i.e. 10 ng/mL final concentration). Fifty microliter aliquots of IgG are added to the target cells and incubated for about 15 minutes at 37°C prior to adding the effector cells to the opsonized target cells.

When IgG titrations are performed, IgG concentration is varied in the range from about .0001 to 1 μ g/mL. IgG dilutions are prepared using a 96-well microtiter plate by diluting the samples in RPMI containing 1% FBS lacking phenol red. The diluted IgG samples are then added to the assay plate containing the target cells.

iv. *Effector cells*

The concentration of the PBMCs are adjusted so that the effector-to-target ratio is in the range of 10-20:1 (i.e. $2-4 \times 10^6$ cells/mL). One hundred microliters of the resuspended PBMCs are added to each well of the opsonized target cells. The plates are incubated at 37°C in the presence of 5% CO₂ for 3-4 hours.

v. *Lactate-dehydrogenase (LDH)-release detection*

Target cell lysis is measured by detecting the release of lactate dehydrogenase enzyme from the cytoplasm of damaged cells into the culture supernatant. Following incubation of the opsonized target cells with the effector cells, the assay plates are centrifuged at 2000 rpm for 5 minutes. About 75 μ L of the cell culture supernatant is carefully removed while the pelleted cells and debris are avoided. This supernatant is added directly to a microtiter plate and to this is added 75 μ L of LDH detection reagent (Roche Cat. No. 1 644 793). The plate is then incubated for approximately 15-30 minutes and the absorbance read at 490 nm using a Molecular Devices Vmax Kinetic Microplate Reader.

vi. *Data Analysis*

All single-point ADCC screening assays are performed in duplicate. Each assay plate contains controls for spontaneous target lysis, spontaneous effector plus target lysis in the absence of IgG and target cell total lysis. Target cell total lysis is achieved by addition of 1% Triton X-100 to the target cells. Three wild type controls are included on each assay plate and the ADCC assay signal averaged. The background value, obtained from the spontaneous lysis controls, is subtracted from each sample. The background value, obtained from the diluted IgG, is subtracted from each sample. The data are converted from absorbance values to percentage of specific-lysis based upon the spontaneous and total lysis controls. The percentage of specific-lysis is calculated from the following equation: percentage specific lysis = (experimental A490 – background A490)/(maximal A490 – background A490) X 100, where background A490 is the sum of the A490 obtained from the effector and target cells in the absence of IgG and the IgG background due to contaminating LDH present in the crude IgG supernatants. The percentage of the Fc variant activity is normalized relative to the averaged wild type controls. The percentage of the normalized activity for duplicate assay plates are averaged and the standard deviation between individual assay plates calculated for each sample.

20

vii. *Results*

The relative ADCC specific activity are shown in Table 7. The CDC values and FcRn binding assays values reported in this table were generated as described below.

Table 7

WT	Variants	ADCC	FcRn 6.0	FcRn 7.0	CDC	n=
D	280A	123	71	51	133	4
D	280H	109	91	90	124	2
D	280K	130	145	131	166	4
D	280N	110	93	61	125	2
D	280T	122	82	23	96	4
K	290D	86	154	25	131	2
K	290N	111	130	17	138	2
K	290P	84	146	34	141	2
K	290T	N/A	148	8	138	2
K	290V	N/A	149	73	140	2

25

B. CDC Activity*i. Assay*

This assay was carried out using human complement (Quidel Corp., cat#A113) on Ramos (RA #1) cell (ATCC Catalog No. CRL-1596). Ramos cells were cultured in Gibco
5 RPMI1640 media containing 10% FBS at 37°C and 5% CO₂. The day before the assay, cells
were seeded at 1 x 10⁶ cells in a T175 flask. The following day, the cells were resuspended
to 3.57 x 10⁵ cells/ml in RPMI1640 without phenol red containing 1% FBS. Distribute 70 µl
cells per well to a Costar 3917 flat bottom plate. For titration curve, variant IgG was
prepared in a 3-fold serial dilution in RPMI1640 media. For single-point library screening
10 assay, transiently expressed IgG variant in culture supernatant was normalized to 1 µg/ml in
mock media. Thirty microliter of variant IgG (i.e. 200 ng/ml final concentration) and 50 µl
of human complement (Quidel Corp., cat#A113) 1:5 diluted in RPMI1640 + 1% FBS was
added to the target cell and mixed well by gentle pipetting. The plates were incubated at
37°C in the presence of 5% CO₂ for 1.5 hours. After addition of 15 µl/well of Alamar Blue
15 (Serotec, cat#BUF012B) the incubation continued overnight. The following morning, the
fluorescence signal was measured by PerkinElmer's EnVision 2100 multilabel reader with
excitation at 560 nm and emission at 590 nm.

ii. Data Analysis

20 All single-point assays were performed in duplicate. Each assay plate contained
controls for spontaneous target cell lysis by human complement in the absence of IgG and
target cell maximal lysis in the presence of 1% Triton X-100. Three wild type controls were
included on each assay plate and the CDC assay signal averaged. The background value,
obtained from the spontaneous lysis control, was subtracted from each sample. The data
25 were converted from fluorescence signals to percentage of specific-lysis based upon
spontaneous and maximal lysis controls. The percentage of specific-lysis was calculated
from the following equation: percentage specific lysis = (experimental fluorescence signal –
spontaneous signal)/(maximal lysis signal – spontaneous signal) X 100. The percentage of
Fc variant activity over the average of three wild type controls was then calculated. The
30 percentage activities over wild type for duplicate assay plates were averaged and the
standard deviation between individual assay plates calculated.

C. FcRn Binding Assays

This section describes assays for Fc neonatal receptor (FcRn) binding to variant IgG. A U-bottom 96-well ELISA plate was coated (Costar) with 50 μ l/well of 2 μ g/ml

5 Neutravidin (Pierce Biotechnology, Cat#31000) in 50 mM Carbonate buffer (pH 9.3) at 4°C overnight. Unbound NeutraAvidin was removed and the plate was washed three times with PBST (PBS containing 0.1% Tween 20). 50 μ l/well biotin-labeled soluble FcRn at 2.5 μ g/ml in PBS was applied and incubated at room temperature for 1 hr. 75 μ l of casein blocking buffer (Pierce Biotechnology, Cat#37528) was then added to the plate for 1 hour.

10 The ELISA plate was then washed with PBST and incubated with 50 μ l/well of variant IgG. For titration curve, variant IgG was prepared by a 3-fold serial dilution in FcRn-binding buffer (100 mM NaPO₄, 0.05% Tween-20 at different pH (from 6.0 to 7.4). For single-point screening, transient expressed variant IgG in culture supernatant was normalized to final concentration of 50 ng/ml (200 ng/ml for pH 7.4 binding) and pH adjusted with FcRn

15 binding buffer to 6.0. In the following steps, FcRn-binding buffer at correspondingly pH was used to wash the plate and to dilute reagents. The binding reaction was carried out at room temperature for 1 hr. After three washes, bound IgG was detected by goat (Fab')₂ anti-human-Fab-HRP conjugate for 1 hr. HRP activity was developed in Pierce's HRP substrate (Turbo TMB-ELISA, Cat#34022) for 5-30 minutes. Reaction was stopped by addition of 50

20 μ l of 2 M H₂SO₄ and the absorbance at 450nm was read with a VMAX microplate reader (Molecular Devices).

All publications and patents mentioned in the above specification are herein incorporated by reference. Various modifications and variations of the described method

25 and system of the invention will be apparent to those skilled in the art without departing from the scope and spirit of the invention. Although the invention has been described in connection with specific preferred embodiments, it should be understood that the invention as claimed should not be unduly limited to such specific embodiments. Indeed, various modifications of the described modes for carrying out the invention which are obvious to

30 those skilled in chemistry, and molecular biology or related fields are intended to be within the scope of the following claims.

We Claim:

1. A composition comprising a variant of a parent polypeptide having at least a portion of an Fc region, wherein said variant has an altered effector function compared to
5 said parent polypeptide and comprises at least one amino acid modification at position 280 in the Fc region.
2. The composition of Claim 1, wherein said variant mediates antibody-
10 dependent cell-mediated cytotoxicity (ADCC) in the presence of effector cells more effectively than said parent polypeptide.
3. The composition of Claim 1, wherein said amino acid modification is D280K
or D280A.
- 15 4. The composition of Claim 1, wherein said amino acid modification is selected from the group consisting of D280H, D280N, and D280T.
5. The composition of Claim 1, wherein said variant comprises an antibody.
- 20 6. The composition of Claim 4, wherein said antibody comprises an unmodified human framework.
7. The composition of Claim 4, wherein said antibody is an anti-CD20
antibody.
- 25 8. The composition of Claim 1, wherein parent polypeptide comprises a human IgG Fc region.
9. The composition of Claim 1, wherein said parent polypeptide comprises a
30 human IgG1, IgG2, IgG3, or IgG4 Fc region.
10. The composition of Claim 1, wherein said parent polypeptide comprises a CH2 region comprising SEQ ID NO:23.

11. A composition comprising a variant of a parent polypeptide having at least a portion of an Fc region, wherein said variant has an altered effector function compared to said parent polypeptide and comprises at least one amino acid modification at position 290 in the Fc region.

5

12. The composition of Claim 11, wherein said variant has higher complement dependent cytotoxicity activity than said parent polypeptide.

13. The composition of Claim 11, wherein said amino acid modification is selected from the group consisting of K290D, K290P and K290N.

10

14. The composition of Claim 11, wherein said amino acid modification is selected from the group consisting of K290T, K290S, and K290V.

15. The composition of Claim 11, wherein said variant comprises an antibody.

15

16. The composition of Claim 14, wherein said antibody comprises an unmodified human framework.

17. The composition of Claim 14, wherein said antibody is an anti-CD20 antibody.

20

18. The composition of Claim 11, wherein parent polypeptide comprises a human IgG Fc region.

25

19. The composition of Claim 11, wherein said parent polypeptide comprises a human IgG1, IgG2, IgG3, or IgG4 Fc region.

20. The composition of Claim 11, wherein said parent polypeptide comprises a CH2 region comprising SEQ ID NO:23.

30

21. A composition comprising a peptide, wherein said peptide comprises an amino acid sequence selected from the group consisting of SEQ ID NOs: 49, 50, 51, 53, and 55-63.

FIGURE 1

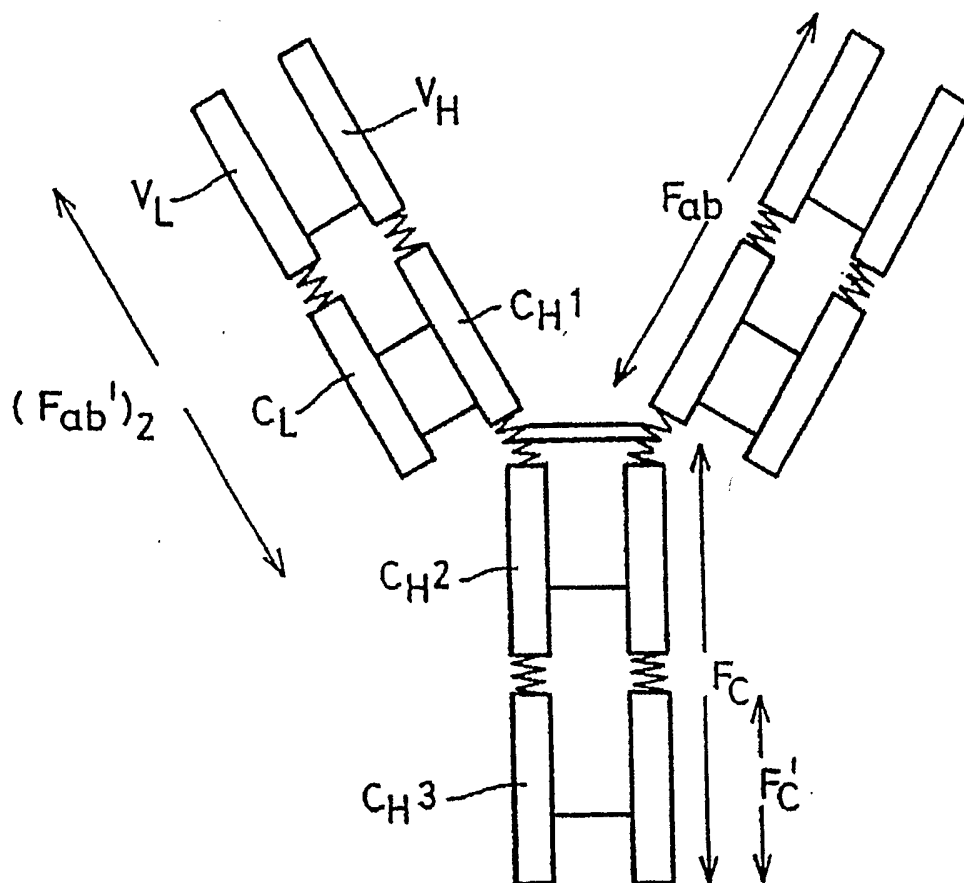



	domains
	inter-domain sections
	disulphide bonds
V	variable
C	constant
L	light chain
H	heavy chain

FIGURE 2

230 hum1gG1 PABELLGGPSVFLFPPPKPKDTLMI SRTPEVTCVAVDVSHEDPEVKNWYV DGEVHNNAKTKPREEQYNSTYRVVSVLTVLHODMNLNGKEYCKKVSNNKALP
 hum1gG2 PAP - PVA G P S V F L F P P P K P K D T L M I S R T P E V T C V A V D V S H E D P E V Q E N W Y V D G E V H N N A K T K P R E Q F N S T F R V V S V L T V H Q D M L N G K E Y C K K V S N K G L P
 hum1gG3 P A P E L L G G P S V F L F P P P K P K D T L M I S R T P E V T C V A V D V S H E D P E V Q E K W Y V D G E V H N N A K T K P R E Q F N S T F R V V S V L T V L H O D M L N G K E Y C K K V S N K A L P
 hum1gG4 P A P E F L G G P S V F L F P P P K P K D T L M I S R T P E V T C V A V D V S Q E D P E V Q F N W Y V D G E V H N N A K T K P R E Q F N S T F R V V S V L T V L H O D M L N G K E Y C K K V S N K G L P
 mur1gG1 - - - T V P E V S S V F L F P P P K I K D V I M I S I S P I V T C V A V D V S E D D P D V Q I S M F V N N V E V H T A Q T Q T H R E D Y N S T I R V V S A L P I O H O D M M S G K E F K C K V A N N K D L P
 mur1gG2A P A P N L L G G P S V F L F P P P K I K D V I M I S I S P I V T C V A V D V S E D D P D V Q I S M F V N N V E V H T A Q T Q T H R E D Y N S T I R V V S A L P I O H O D M M S G K E F K C K V A N N K D L P
 mur1gG2B P A P N L E G G P S V F L F P P P N I K D V I M I S L T P K V T C V A V D V S E D D P D V Q I S M F V N N V E V H T A Q T Q T H R E D Y N S T I R V V S A L P I O H O D M M S G K E F K C K V A N N K D L P
 mur1gG3 P P G N I L G G P S V F L F P P P K P K D A L M I S L T P P K V T C V A V D V S E D D P D V H V S M F V D N K E V H T A M T Q P R E A Q Y N S T F R V V S A L P I O H O D M M R G K E F K C K V A N N K A L P

330 hum1gG1 A P I E K T I S K A K G Q R E P Q V Y T L P P S R E M T K N Q V S L T C L V K G F Y P S D I A V E M E S N G Q P E N N Y K T T P P V L D S D G S F F L Y S K L F T V D K S R M Q Q G N V F S G S V M H
 380

430 hum1gG2 A P I E K T I S K T K G Q R E P Q V Y T L P P S R E M T K N Q V S L T C L V K G F Y P S D I A V E M E S N G Q P E N N Y K T T P P M L D S D G S F F L Y S K L F T V D K S R M Q Q G N V F S G S V M H
 hum1gG3 A P I E K T I S K T K G Q R E P Q V Y T L P P S R E M T K N Q V S L T C L V K G F Y P S D I A V E M E S S G Q P E N N Y N T T P P M L D S D G S F F L Y S K L F T V D K S R M Q Q G N I F S G S V M H
 hum1gG4 S S I E K T I S K A K G Q R E P Q V Y T L P P S Q E M T K N Q V S L T C L V K G F Y P S D I A V E M Z S N G Q P E N N Y K T T P P V L D S D G S F F L Y S R L T V D K S R M Q E A G N T F T G S V L H
 mur1gG1 A P I E K T I S K T K G R P K A P Q V Y T I P P P E Q M A K D K V S L T C M I T D F P E D I T V E M Q M N G Q P A E N Y K N T Q P I M D T D G S Y F Y S K L A N V Q K S N M E A G N T F T G S V L H
 mur1gG2A A P I E R T I S K P K G S V R A P Q V Y V L P P P E E M T K Q V T L T C M V T D E M E D I Y V E W T N N G K T E L N Y K N T E P V L D S D G S Y F M Y S K L R E K K M W E R N S Y S C S V V H
 mur1gG2B S P I E R T I S K P K G L V R A P Q V Y T L P P P A B Q L S R K D V S L T C L V V G F N D G I S V E W T S N G H T E E N Y K D T A P V L D S D G S Y F I Y S K L M M K T S K W E K T D S F S G M V R H
 mur1gG3 A P I E R T I S K P K G R A Q T P Q V Y T I P P P R E Q M S K K V S L T C I V T N F S E A I S V E M E R N G H L E Q D Y K N T P P I L D S D G T Y F L Y S K L F T V D T D S W L Q G E I F T C S V V H

430 hum1gG1 E A L H N H Y T Q K S I S L S P G K (S E Q I D N O : 1 5)
 hum1gG2 E A L H N H Y T Q K S I S L S P G K (S E Q I D N O : 1 6)
 hum1gG3 E A L H N R F T Q K S I S L S P G K (S E Q I D N O : 1 7)
 hum1gG4 E A L H N H Y T Q K S I S L S I G K (S E Q I D N O : 1 8)
 mur1gG1 E G L H N H H T E K S I S H S P G K (S E Q I D N O : 1 9)
 mur1gG2A E G L H N H H T T K S F S R T P G K (S E Q I D N O : 2 0)
 mur1gG2B E G L K N Y Y L K K T T S R S P G K (S E Q I D N O : 2 1)
 mur1gG3 E A L H N H H T T Q K N L S R S P G K (S E Q I D N O : 2 2)

FIGURE 3

A. Parental CH2 (SEQ ID NO:23)

APELLGGPSVFLFPPKPKDTLMISRTPEVTCVVVDVSHEDPEVKFNWYVDGVEVHNAKTKP
REEQYNSTYRVVSVLTVLHQDWLNGKEYKCKVSNKALPAPIEKTISKAK

B. Parental CH3 (SEQ ID NO:24)

GQPREPQVYTLPPSREEMTKNQVSLTCLVKGFYPSDIAVEWESNGQPENNYKTTPPVLDSD
GSFFLYSKLTVDKSRWQQGNVFCSCVMHEALHNHYTQKSLSLSPGK

C. Parental Polypeptide (SEQ ID NO:25)

STKGPSVFPLAPSSKSTSGGTAALGCLVKDYFPEPVTVSWNSGALTSGVHTFPAVLQSSGLY
SLSSVVTVPSSSLGTQTYICNVNHKPSNTKVDKRVVEPKSCDKTHTCPPCPAPELLGGPSVFL
FPPKPKDTLMISRTPEVTCVVVDVSHEDPEVKFNWYVDGVEVHNAKTKPREEQYNSTYRV
VSVLTVLHQDWLNGKEYKCKVSNKALPAPIEKTISKAKGQPREPQVYTLPPSREEMTKNQ
VSLTCLVKGFYPSDIAVEWESNGQPENNYKTTPPVLDSDGSFFLYSKLTVDKSRWQQGNV
FCSCVMHEALHNHYTQKSLSLSPGK

D. Parental Polypeptide (SEQ ID NO:48)

STKGPSVFPLAPSSKSTSGGTAALGCLVKDYFPEPVTVSWNSGALTSGVHTFPAVLQSSGLY
SLSSVVTVPSSSLGTQTYICNVNHKPSNTKVDKRVVEPKSCDKTHTCPPCPAPELLGGPSVFL
FPPKPKDTLMISRTPEVTCVVVDVSHEDPEVKFNWYVDGVEVHNAKTKPREEQYNSTYRV
VSVLTVLHQDWLNGKEYKCKVSNKALPAPIEKTISKAKGQPREPQVYTLPPSRDELTKNQ
SLTCLVKGFYPSDIAVEWESNGQPENNYKTTPPVLDSDGSFFLYSKLTVDKSRWQQGNVFS
CSVMHEALHNHYTQKSLSLSPGK

FIGURE 4

- A. Y300I - SEQ ID NO:26 AKTKPREEQYNSTIRVVSVL
- B. Y300L - SEQ ID NO:27 AKTKPREEQYNSTLRVVSVL
- C. Q295K - SEQ ID NO:28 AKTKPREEKYNSTYRVVSVL
- D. E294N - SEQ ID NO:29 AKTKPRENQYNSTYRVVSVL
- E. S298N - SEQ ID NO:30 AKTKPREEQYNNTYRVVSVL
- F. S298V - SEQ ID NO:31 AKTKPREEQYNVTYRVVSVL
- G. S298D - SEQ ID NO:32 AKTKPREEQYNDTYRVVSVL
- H. Q295L - SEQ ID NO:33 AKTKPREELYNSTYRVVSVL
- I. S298P - SEQ ID NO:34 AKTKPREEQYNPTYRVVSVL
- J. Y296P - SEQ ID NO:35 AKTKPREEQPNSTYRVVSVL

FIGURE 5

A. Parental Oligonucleotide (SEQ ID NO:36)

tccaccaagggcccatcggtcttccccctggcaccctcctccaagagcacctctgggggacacagcggccctgggct
gcctgggtcaaggactacttccccgaaccggtgacgggtgctcgtggaactcagggcgccctgaccagcggcgtgcacac
cttccccggctgtcctacagtctcaggactctactccctcagcagcgtgggtgaccgtgcccctccagcagcttgggc
accagacctacatctgcaacgtgaatcacaagcccagcaacaccaaggtggacaagagagttgagcccaaatctt
gtgacaaaactcacacatgcccaccgtgcccagcacctgaactcctggggggaccgtcagtccttctcttcccccc
aaaaccaaggacaccctcatgatctcccggaccctgaggtcacatgctggtgggtggacgtgagccacgaagac
cctgaggtcaagttcaactggtacgtggacggcgtggaggtgcataatgccaagacaaagccgaggaggagcagt
acaacagcacgtaccgtgtggtcagcgtcctcaccgtcctgcaccaggactggctgaatggcaaggagtacaagtg
caaggtctccaacaaagccctcccagccccatcgagaaaaccatctccaaagccaaaggtcagccccgagaacca
caggtgtacaccctgccccatcccgggaggagatgaccaagaaccaggtcagcctgacctgcctggtcaaaggct
tctatcccagcgacatcgccgtggagtgaggagcaatgggcagccggagaacaactacaagaccacgcctcccgt
gctggactccgacggctccttcttctctacagcaagctcaccgtggacaagagcaggtggcagcaggggaacgctc
ttctcatgctccgtgatgcatgaggctctgcacaaccactacacgcagaagagcctctcctgtccccgggtaa

B. Parental Oligonucleotide (SEQ ID NO:37)

acaaagccgaggaggagcagtagacaacagcacgtaccgtgtgggtcagcgtc

FIGURE 6

- A. Y300I - SEQ ID NO:38 acaaagccgcgggaggagcagtacaacagcacgatt
- B. Y300L - SEQ ID NO:39 acaaagccgcgggaggagcagtacaacagcacgctg
- C. Q295K - SEQ ID NO:40 acaaagccgcgggaggagaagtacaacagcacgtac
- D. E294N - SEQ ID NO:41 acaaagccgcgggagaaatcagtacaacagcacgtac
- E. S298N - SEQ ID NO:42 acaaagccgcgggaggagcagtacaacaatacgtac
- F. S298V - SEQ ID NO:43 acaaagccgcgggaggagcagtacaacgttacgtac
- G. S298D - SEQ ID NO:44 acaaagccgcgggaggagcagtacaacgatacgtac
- H. Q295L - SEQ ID NO:45 acaaagccgcgggaggagtgtacaacagcacgtac
- I. S298P - SEQ ID NO:46 acaaagccgcgggaggagcagtacaaccctacgtac
- J. Y296P - SEQ ID NO:47 acaaagccgcgggaggagcagccgaacagcacgtac

FIGURE 7

CHO Cell vs. 293 Expressed IgG

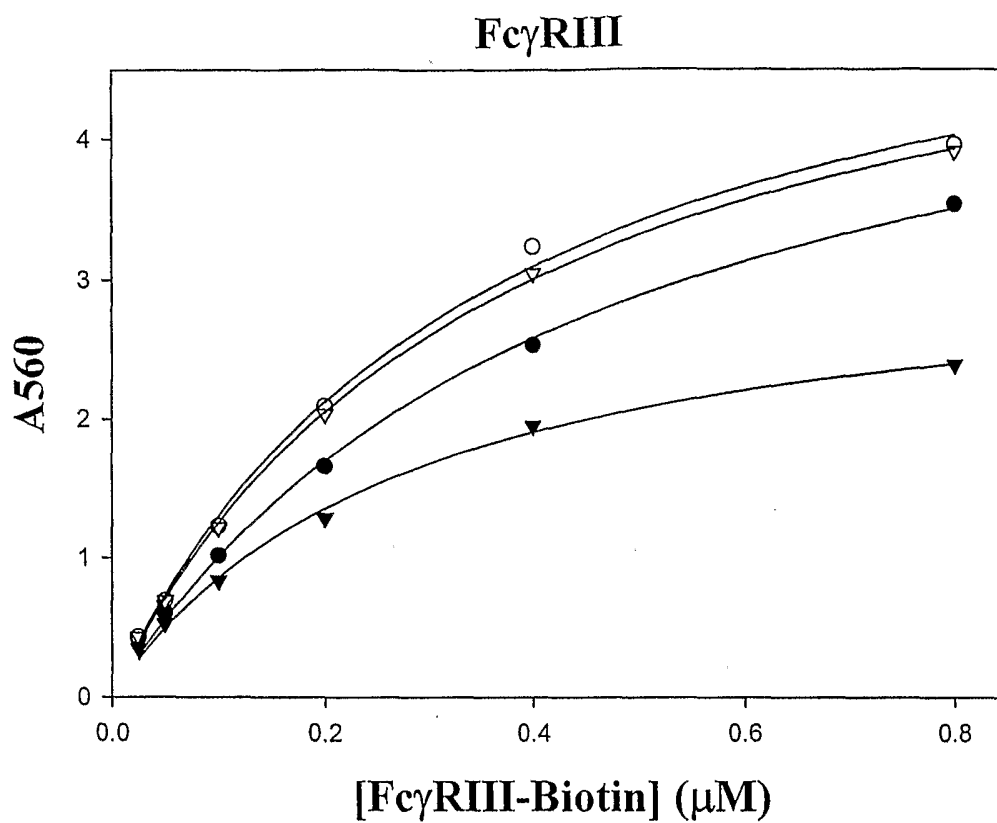

open circles = S298D 293
 open triangles = S298D CHO
 closed circles = WT 293
 closed triangles = WT CHO

FIGURE 8

CHO Cell vs. 293 Expressed IgG

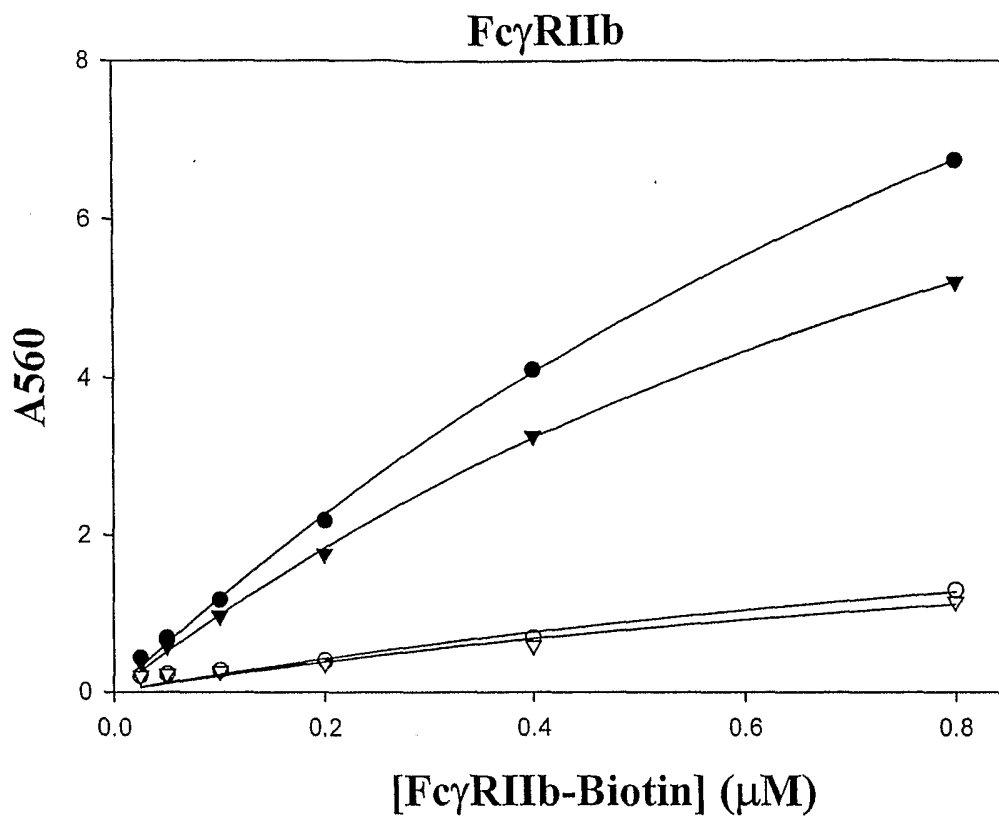

closed circles = WT 293
 closed triangles = WT CHO
 open circles = S298D CHO
 open triangles = S298D 293

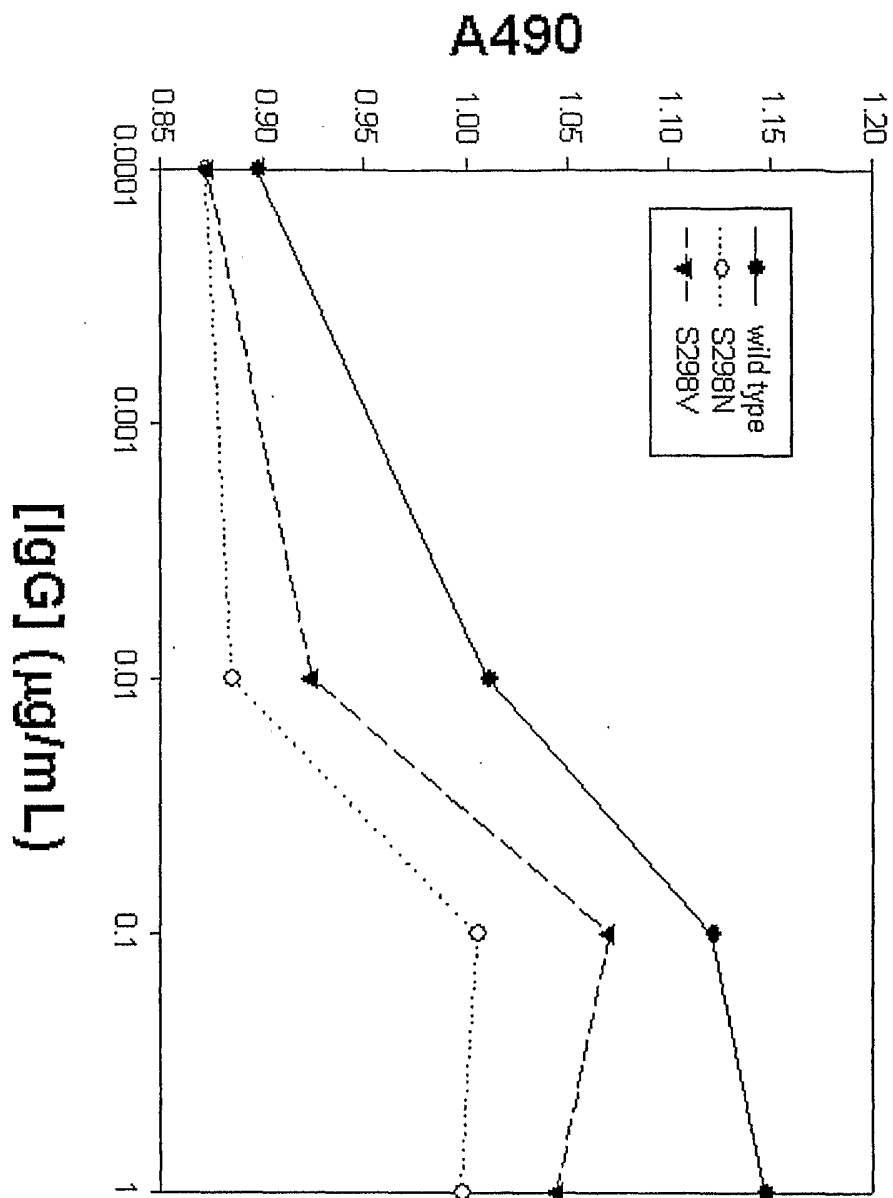
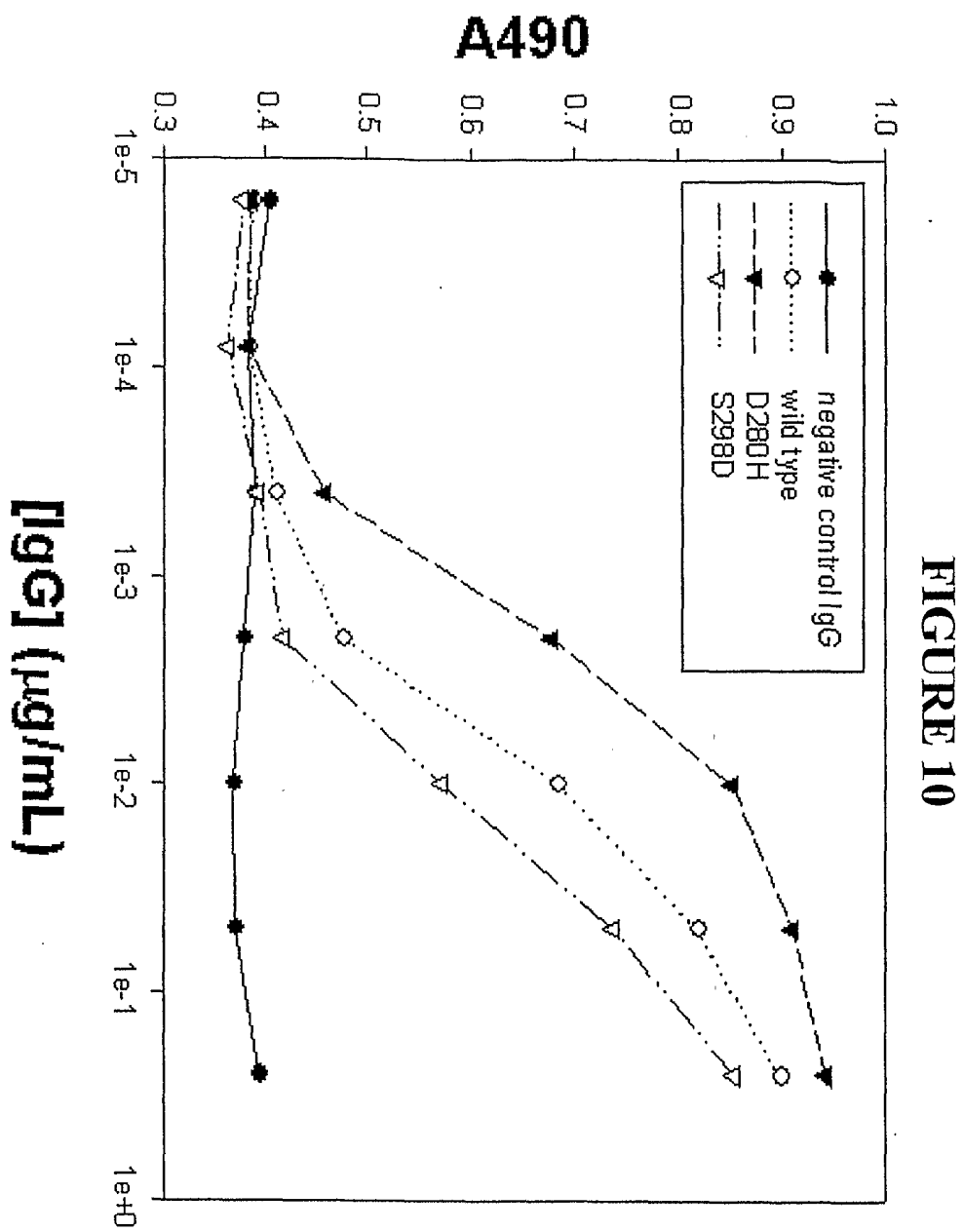

FIGURE 9



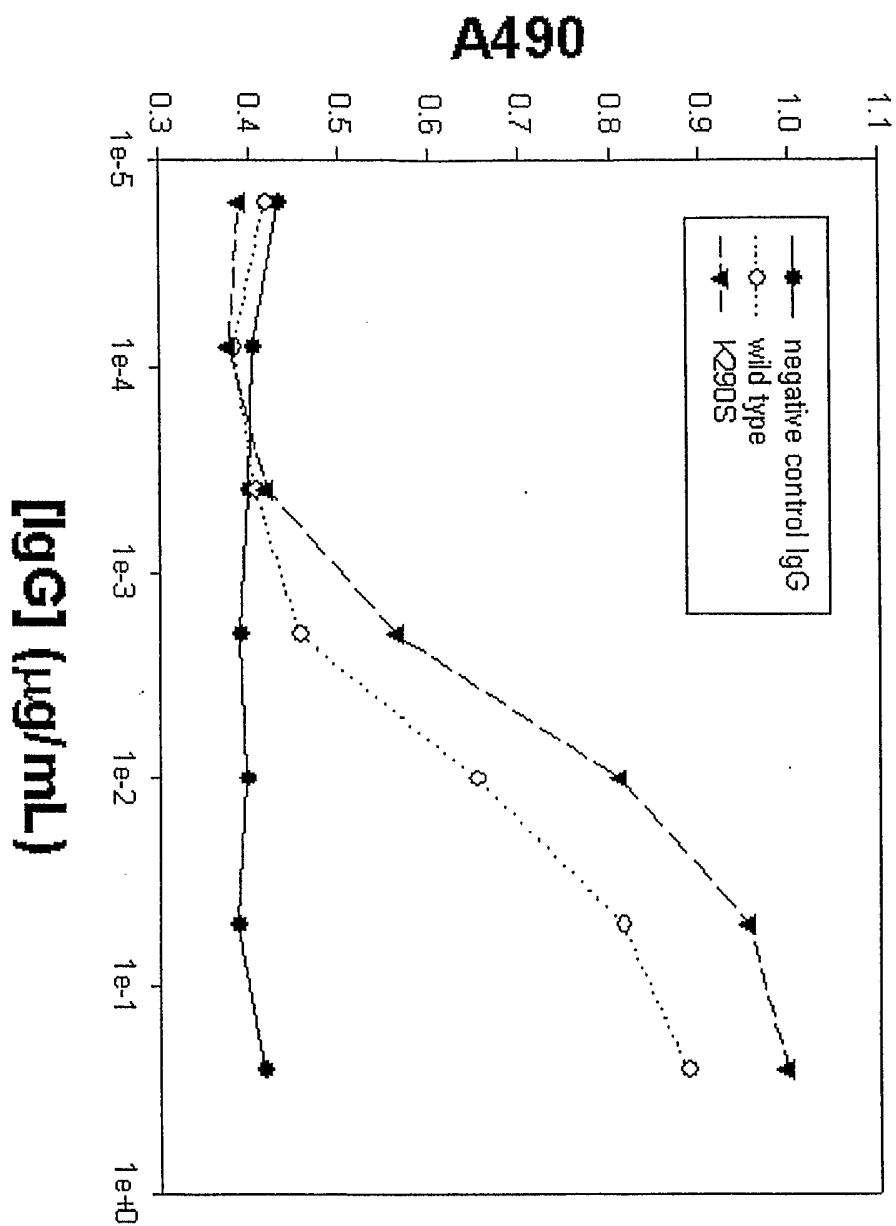

FIGURE 11

FIGURE 12

A. Amino Acid Sequence of D280H Variant CH2 Region (SEQ ID NO:51).

APELLGGPSVFLFPPKPKDTLMISRTPEVTCVVVDVSHEDPEVKFNWYVHGVEV
HNAKTKPREEQYNSTYRVVSVLTVLHQDWLNGKEYKCKVSNKALPAPIEKTISK
AK

B. Nucleic Acid Sequence Encoding D280H Variant CH2 Region (SEQ ID NO:52).

GCACCTGAACTCCTGGGGGGACCGTCAGTCTTCCTCTTCCCCC AAAACCCAAGGACAC
CCTCATGATCTCCCGGACCCCTGAGGTCACATGCGTGGTGGTGGACGTGAGCCACGAAG
ACCCTGAGGTCAAGTTCAACTGGTACGTGCATGGCGTGGAGGTGCATAATGCCAAGACA
AAGCCGCGGGAGGAGCAGTACAACAGCACGTACCGTGTGGTCAGCGTCCTCACCGTCCT
GCACCAGGACTGGCTGAATGGCAAGGAGTACAAGTGCAAGGTCTCCAACAAAGCCCTCC
CAGCCCCCATCGAGAAAACCATCTCCAAGCCAAA

C. Amino Acid Sequence of K290S Variant CH2 Region (SEQ ID NO:53).

APELLGGPSVFLFPPKPKDTLMISRTPEVTCVVVDVSHEDPEVKFNWYVDGVEV
HNAKTS PREEQYNSTYRVVSVLTVLHQDWLNGKEYKCKVSNKALPAPIEKTISK
AK

D. Nucleic Acid Sequence Encoding K290S Variant CH2 Region (SEQ ID NO:54).

GCACCTGAACTCCTGGGGGGACCGTCAGTCTTCCTCTTCCCCC AAAACCCAAGGACAC
CCTCATGATCTCCCGGACCCCTGAGGTCACATGCGTGGTGGTGGACGTGAGCCACGAAG
ACCCTGAGGTCAAGTTCAACTGGTACGTGGACGGCGTGGAGGTGCATAATGCCAAGACA
TCACCGCGGGAGGAGCAGTACAACAGCACGTACCGTGTGGTCAGCGTCCTCACCGTCCT
GCACCAGGACTGGCTGAATGGCAAGGAGTACAAGTGCAAGGTCTCCAACAAAGCCCTCC
CAGCCCCCATCGAGAAAACCATCTCCAAGCCAAA

FIGURE 13

A.	D280H - SEQ ID NO:49	VKFNWYVHGVEVHNA
B.	D280A - SEQ ID NO:55	VKFNWYVAGVEVHNA
C.	D280K - SEQ ID NO:56	VKFNWYVKGVEVHNA
D.	D280N - SEQ ID NO:57	VKFNWYVNGVEVHNA
E.	D280T - SEQ ID NO:58	VKFNWYVTGVEVHNA
F.	K290S - SEQ ID NO:50	EVHNAKTSPREEQYN
G.	K290D - SEQ ID NO:59	EVHNAKTDPREEQYN
H.	K290N - SEQ ID NO:60	EVHNAKTNPREEQYN
I.	K290P - SEQ ID NO:61	EVHNAKTTPREEQYN
J.	K290T - SEQ ID NO:62	EVHNAKTTPREEQYN
K.	K290V - SEQ ID NO:63	EVHNAKTVPREEQYN