

[72] Inventors **Jewel M. McGavic**  
 1072 Brownlee, Memphis, Tenn. 38116;  
**Doyle A. Johnson**, 4120 Village Road,  
 Memphis, Tenn. 38117

[21] Appl. No. 2,523

[22] Filed **Jan. 13, 1970**

[45] Patented **Aug. 31, 1971**

[56] **References Cited**

UNITED STATES PATENTS		
587,541	8/1897	Witherspoon..... 116/87
1,330,698	2/1920	Fujita et al..... 116/75
3,238,874	3/1966	Richards..... 116/105 X

*Primary Examiner*—Louis J. Capozzi  
*Attorney*—Browdy and Neimark

[54] **BURGLAR-FIRE ALARM**  
 7 Claims, 4 Drawing Figs.

[52] U.S. Cl..... 116/87,  
 102/37

[51] Int. Cl..... G08b 13/08

[50] Field of Search..... 116/6, 11,  
 12, 15, 17, 75, 78, 81, 83, 85, 87, 86, 88, 89, 105;  
 86/10; 102/37, 37.4, 37.7

**ABSTRACT:** An alarm which may be used as a warning of the unauthorized intrusion of a burglar, or the existence of a fire. Three spring urged hammers, containing either a blank cartridge or a percussion cap, are held in cocked position by a retaining bar. When either of the monitored conditions occurs, the retaining bar is released, freeing the hammers in sequential order so that the cartridges or caps are exploded. Movement of the retaining bar is controlled by an air cylinder which determines the pause between successive striking of the hammers.

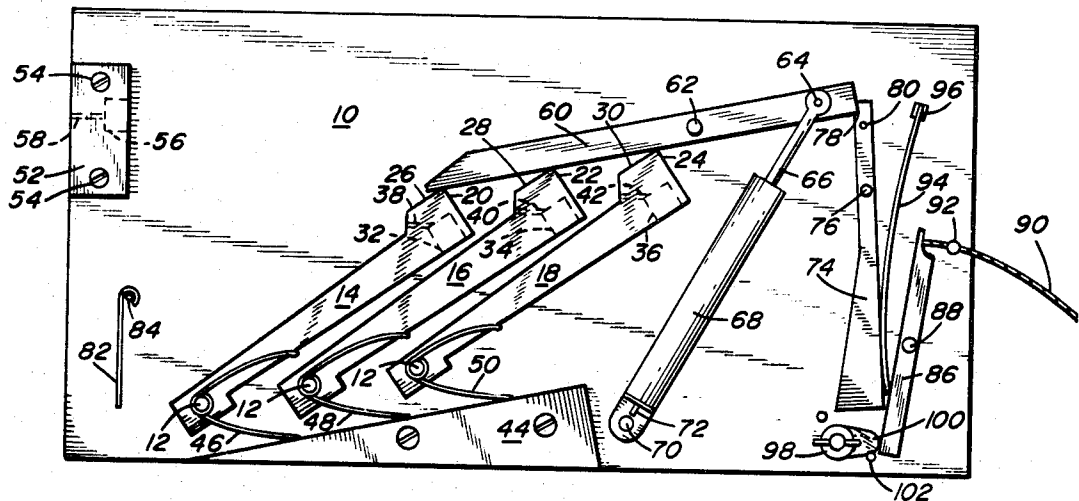

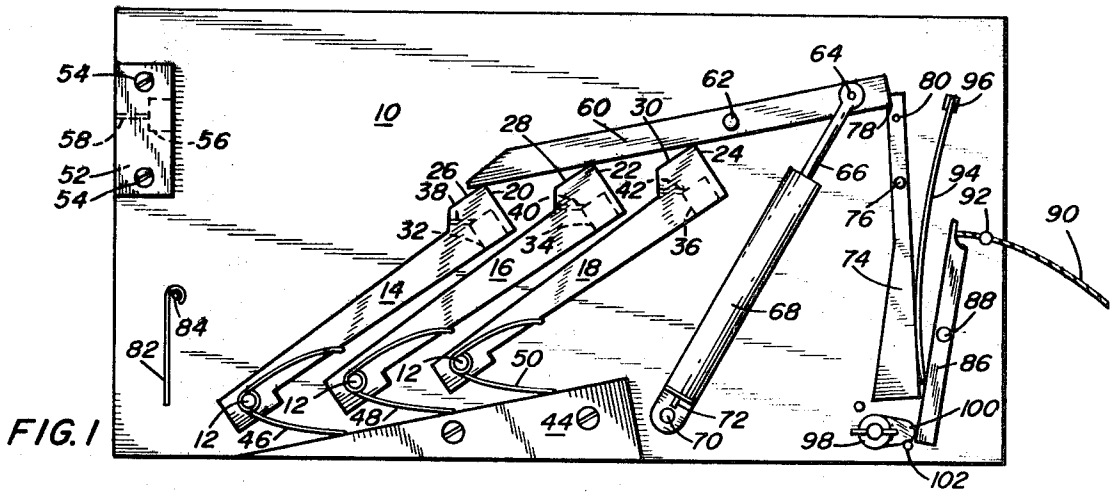

FIG. 1

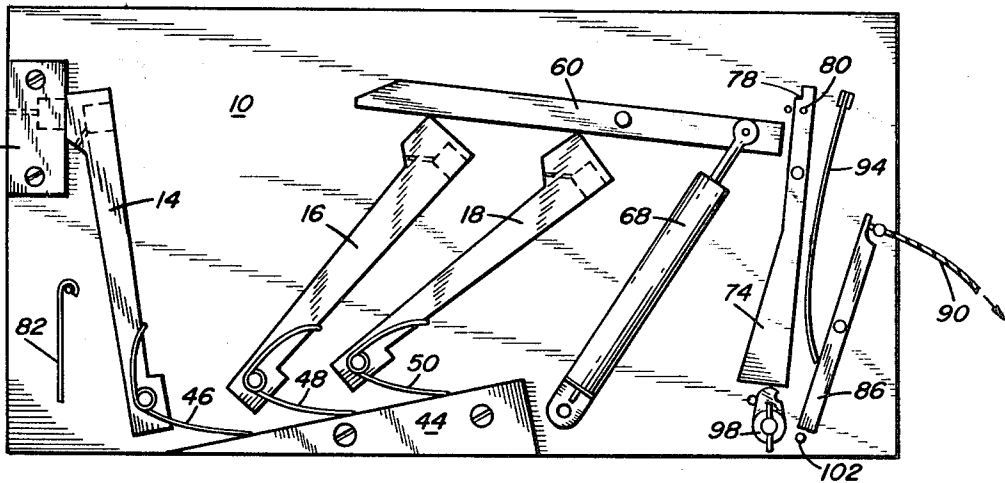

FIG. 2

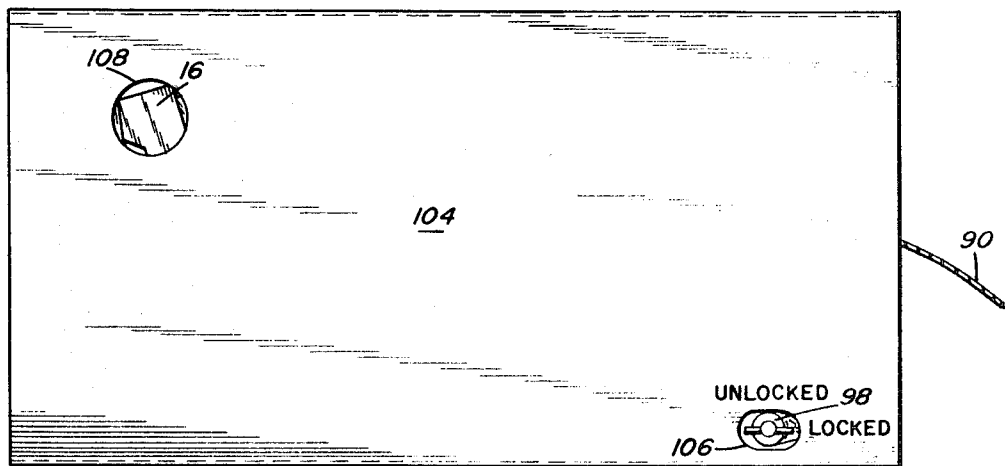

FIG. 3

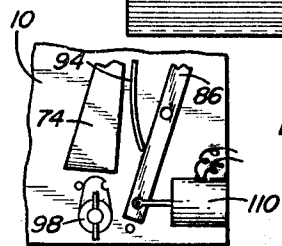

FIG. 4

INVENTORS  
**JEWEL M. McGAVIC**  
**DOYLE A. JOHNSON**  
 BY

*Browdy and Neimark*  
 ATTORNEYS

**BURGLAR-FIRE ALARM**

The present invention relates to burglar-fire alarms and more particularly to a burglar-fire alarm which may be used on either doors or windows and which emits a loud audible noise when the device is triggered by a prowler or by the excessive heat of a fire.

Burglar alarms per se are old in the art, for man has long sought to protect his home, his belongings and his family, from the unknown intruder. The most common burglar alarms today are electrically controlled and adapted to sound the alarm system whenever an opened door or window closes the circuit. Although reasonably effective, these electrical systems are expensive to install in the home and, of course, are useless in the event of a power failure. Furthermore, their utility is lost if the professional burglar can cut the wires leading to the alarm.

It follows, therefore, that a self-acting alarm, which is not reliant upon electrical power, would have certain advantages over complete electrical systems. These self-acting alarms are generally much more economical than the electric alarms, for the electrical elements tend to be more expensive than elements which are purely mechanical. Then, too, these self-acting alarms cannot be jammed by any power failure or the like. However, these prior art mechanical self-acting alarms have certain disadvantages too. Some of them are designed to sound an alarm as a swinging door is opened, but since the action of a sliding window sash is different from a swinging door, these "door" alarms cannot be adapted to be used on a window. This same problem applies to these self-acting alarms that are used on windows in that their alarm releasing means is not versatile enough to permit their effective use on both sliding windows and swinging doors.

Another disadvantage of many prior art self-acting alarms is that they employ various systems of coil springs and gearwheels to operate the alarm. The first disadvantage of this type of assembly is in the greater expense of manufacture. Coil springs, as compared to compression springs, are much more expensive for among other things they require a special steel out of which they are fabricated. Likewise, the gearwheels are often precision made.

A further disadvantage of many burglar alarms is that the sounding device many times cannot be distinguished from the many horns, bells and other common sounds that might be heard anytime in a dwelling along a busy thoroughfare. If the sounding device cannot be heard or distinguished from other sounds of the night, the alarm is obviously of no use.

The present invention offers many improvements and advantages over known prior burglar and fire alarms. The device is self-contained and self acting, it emits a series of distinctive and clearly distinguishable audible signals when activated, it is not susceptible to being jammed, and it may be located across doors, windows, or anywhere else in a house.

An object of the present invention is the provision of a burglar and fire alarm which is a self-acting mechanism that will effectively resist being jammed and thus rendered inoperative.

Another object of the present invention is the provision of a burglar and fire alarm which emits a sound that is easily heard in a dwelling and is clearly distinguishable from other similar sounds.

Still another object of the present invention is the provision of a burglar and fire alarm which can be used over doors, or elsewhere in any enclosure being monitored.

Yet another object of the present invention is the provision of a burglar and fire alarm which emits a series of timed, sequential signals when activated.

Other objects and many of the attendant advantages of the present invention will be more readily appreciated as the same becomes better understood by reference to the following detailed description when considered in connection with the accompanying drawings in which like reference numerals designate like parts throughout the figures thereof and where:

FIG. 1 shows a view of the alarm when it is in a locked or secure position;

FIG. 2 shows a view of the alarm after it has been tripped and the first signal has been sounded;

FIG. 3 shows a view of the alarm with its lid in place, and as it will appear when mounted for operation;

FIG. 4 shows a fragmentary view of the alarm to illustrate a modification wherein the alarm is triggered by a solenoid.

Referring now to the drawings there is shown in FIG. 1 an overall view of the combination burglar and fire alarm comprising the invention and wherein there is shown a rectangular baseplate 10 which is used to support the various components of the invention. Baseplate 10 is removably attached to a mounting bracket (not shown) which is fastened to a window frame, door jamb, or the like, wherever the device is to be installed, base 10 being removed from its mounting bracket in order to facilitate the insertion of blank cartridges, or percussion caps, as will be described more fully hereinafter.

Pivotaly mounted on base 10, at one end as by a pin 12, there are a plurality of hammers 14, 16 and 18, and the number of hammers employed may be any number, but three have been chosen in this embodiment. The hammers 14, 16 and 18 are several inches in length and have enlarged portions 20, 22 and 24 at their free-moving ends. On the forward side of enlarged portions 20, 22 and 24 there are flat faces 26, 28 and 30 while on the backside of enlarged portions 20, 22 and 24 there are hollow chambers 32, 34 and 36. These chambers are used for holding blank cartridges and small holes 38, 40 and 42 are drilled through the enlarged portions connecting chambers 32, 34 and 36 with the outside atmosphere so as to provide a means of escape for gases generated by the exploding cartridges.

Just below the hammers 14, 16 and 18 there is a triangular-shaped spring retainer block 44 which is permanently fastened to base 10. It may be observed that the slanting plane of block 44 is parallel with a line through the hammer pivot pins 12, this plane serving as a support for a plurality of coiled springs 46, 48 and 50. The coiled springs, when wrapped around pins 12 and with one end hooked around a hammer and the other end pressing against block 44, will provide a motivating force for rotating the hammers about pins 12.

To the left of the first hammer 14 there is an anvil 52 permanently mounted to base 10 as by screws 54, the anvil having a cartridge chamber 56 and a vent hole 58 similar to those located in the ends of the hammers. The position of anvil 52 is so chosen that it is not beyond the arc of rotation of hammer 14 and as a consequence the hammer will strike the anvil a substantial blow when the hammer is released, the blow being sufficient to fire a cartridge placed in chamber 56, as will be described more fully hereinafter.

Extending almost horizontally across the movable ends of hammers 14, 16 and 18 there is a hammer retaining bar 60 to hold the hammers in a cocked position. The bar 60 pivots about a pin 62 located slightly to one side of the center of the bar and screwed into base 10. Near the extreme right end of bar 60 there is a rotatable connection 64, which is used to join bar 60 with the plunger 66 of an air cylinder 68, or dashpot, the closed end of cylinder 68 being rotatably mounted on base 10 as by a screw 70. A small bleed hole 72 is drilled in the lower end of cylinder 68 to control the escape of air from the cylinder and therefore the speed at which it operates.

In order to complete the cocking mechanism of the invention, there is a cocking lever 74 which is pivoted near its upper end by a pin 76. Beyond pin 76 and at the extreme end of the lever there is a small notch 78 cut in one side of the lever, this notch being of sufficient size, and cut at the proper angle, to receive the square, outer corner of hammer retaining bar 60, and therefore preventing retaining bar 60 from turning about pin 62, to retain the alarm in a cocked position.

A small hole 80 is drilled through the upper end of lever 74 so that it can be aligned with a similar hole (not shown) drilled in base 10. Should it be desired to completely secure, or disable, the alarm against accidental firing, as when the cartridges or percussion caps are being installed, for example, a short length of stiff wire 82 may be inserted through hole 80 in lever 74 so that it extends into base 10, and thus functions as a

safety pin by preventing movement of the cocking lever. When safety pin 82 is not in use, it is attached to a short stud 84, located at one side of base 10.

Just to the right side of cocking lever 74 there is an actuator arm 86 which is pivoted midway of its length, about a pin 88, the upper end of the arm having attached thereto a thin cord 90, or fine link chain, which passes through a circular eyelet 92 and extends out beyond the case, the remote end of cord 90 being attached to a movable window sash door, or entrance way which is being protected from intrusion. Should cord 90 be pulled, actuator arm 86 will turn so that its lower end will press against the bottom of cocking lever 74 to trip the alarm.

The fire alarm feature of the invention is provided by a bimetallic strip 94 which is rigidly fastened at one end to base 10 by a brad 96. The movable end of the strip is positioned very close to the lower end of cocking lever 74 so that when the strip bends due to heat, it will move lever 74 to trip the alarm.

In addition to safety pin 82, there is provided a further locking means in the form of a rotatable key 98. Locking key 98 is mounted on base 10 and has a small projection 100 extending out from the periphery of its base. A limit stop 102 is also provided so that when key 98 is turned to its locked position, with projection 100 against limit stop 102, then projection 100 will be in contact with the bottom of actuator bar 86, preventing its movement.

Turning to FIG. 3, there is shown a view of the invention with its lid 104 in place. A slightly oval hole 106 is provided to make the outer end of key 98 accessible, while another hole, or window 108 serves as an indicator to show that the alarm has been fired, the heads of hammers 14, 16 and 18 being painted red, will be visible through window 108 when they are in their fired position.

In the modification of FIG. 4 there has been added an electric solenoid 110 to serve as the actuating means in place of cord 90. In this embodiment, when an electric switch (not shown) is closed by the opening of a window or door, for example, the solenoid 110 is energized to move actuator bar 86 and set off the alarm.

Turning now to the operation of the device, it must first be armed. The base 10, with its associated components, is removed from its mounting bracket on the wall, and cover lid 104 is removed. Next, the third hammer, 18, is rotated clockwise about pin 12 to its cocked position, shown in FIG. 1, followed by the same maneuver for hammers 16 and 14. With the three hammers held together, and rotated to compress springs 46, 48 and 50, hammer retaining bar 60 is pressed downward to hold the hammers in place while cocking lever 74 is moved until the corner of bar 60 rests in notch 78. This places the alarm in a cocked position, and at the same time extends plunger 66 of air cylinder 68.

Once the alarm is cocked, safety pin 82 is removed from its holders 84 and its straight end is inserted into hole 80 to prevent accidental tripping of the alarm. Now blank cartridges, to provide the explosive force, are inserted into chamber 56 in anvil 52, and in chambers 32 and 34 of hammers 14 and 16. It is not necessary to load chamber 36 in hammer 18, as will be obvious hereinafter. As an alternative method of loading the alarm percussion caps may be used in place of the cartridges, and they may be adhered to the faces 26, 28 and 30 of hammers 14, 16 and 18 respectively.

Locking key 98 is turned until projection 100 contacts limit stop 102 and the bottom of actuator bar 86, thereby retaining the alarm in a locked condition while pin 82 is removed, lid 104 is replaced and the device returned to its mounting bracket on the wall. Cord 90 is now attached to a window, door, etc. as desired, or in the modification of FIG. 4 solenoid 110 is connected to its switch and source of potential. Next

locking key 98 is turned counterclockwise to unlock the mechanism and thereby arm the device.

Should movement of either cord 90 or solenoid 110 move actuator bar 86, the bar will press against cocking lever 74 to dislodge retainer bar 60 from notch 78. Likewise as a fire alarm, bimetallic strip 94 will bend to move cocking lever 74 out of engagement with bar 60. In either of these situations air cylinder 68 will immediately start to move retaining bar 60 out of engagement with the hammers, its speed of action being regulated by the size of bleedhole 72 releasing the air.

Since hammer 14 is very near the end of bar 60, as soon as the bar moves the hammer will be released so that it strikes anvil 52 exploding the cartridge or percussion cap therein. Also, immediately, hammer 16 will be released firing the cartridge in hammer 14, followed by a third firing in about 20 to 30 seconds as hammer 18 is released. Three shots are fired, two as soon as the alarm is triggered, followed by a third after a short delay. After the alarm has been fired, the red hammers can be seen through the indicator window 108, to warn that the alarm must be recharged.

From the above description of the structure and operation of the present invention, it is obvious that the device offers a new, effective, and highly reliable burglar and fire alarm, which may be located in a variety of places. The alarm is fast, self-acting, virtually jam proof, and emits a series of timed, sequential reports, which are highly effective in scaring off any unwanted intruder, or in warning a person within earshot of the presence of fire.

Many modifications and variations of the present invention are possible in the light of the above teachings. It is therefore to be understood, that within the scope of the appended claims, the invention may be practiced otherwise than as specifically described.

What is claimed is;

1. A burglar-fire alarm comprising a plurality of spring urged striking hammers; mounted in tandem; an anvil to be struck by the first hammer; first detonating means in said anvil located so as to be struck by said first hammer, additional detonating means located in each of said hammers so as to be struck by said additional hammers; a retaining bar mounted so as to hold all of the hammers in a cocked position, and for releasing them in sequence; a cocking lever for holding the retaining bar; and an actuating bar for moving the cocking lever to release the retaining bar when the alarm is triggered whereby when said retaining bar is released the plurality of hammers are released in sequence to actuate said detonating means in sequence.
2. The alarm of claim 1 further including an air cylinder connected to the retaining bar for determining the speed of movement of the retaining bar, and therefore the speed at which the hammers are sequentially released.
3. The alarm of claim 2 further including cord means connected from the actuator bar to a window or door which is being protected from intrusion whereby said actuator bar is actuated by a pull on said cord.
4. The alarm of claim 2 further including a heatsensitive means adapted to actuate the cocking lever and trigger the alarm in case of fire.
5. The alarm of claim 2 further including a safety pin, for insertion through the cocking lever, to hold it immobile while the detonators are being installed.
6. The alarm of claim 2 further including a locking key for securing and releasing the actuator bar.
7. The alarm of claim 2 further including electrically energizable means for triggering the actuator bar.