

(12) UK Patent Application (11) GB (11) 2 358 032 (13) A

(43) Date of A Publication 11.07.2001

(21) Application No 0000006.7

(22) Date of Filing 05.01.2000

(71) Applicant(s)
Sedco Forex International Inc
(Incorporated in Panama)
8 Calle Aquilino de la Guardia, Panama City, Panama

(72) Inventor(s)
Peter Airey

(74) Agent and/or Address for Service
Fitzpatricks
4 West Regent Street, GLASGOW, G2 1RS,
United Kingdom

(51) INT CL⁷
E21B 33/064

(52) UK CL (Edition S)
E1F FAY FJG

(56) Documents Cited
WO 98/58152 A US 5069488 A US 3917006 A

(58) Field of Search
UK CL (Edition R) E1F FAY FJA FJB FJG
INT CL⁷ E21B 7/12 7/128 17/01 19/00 19/09 33/043
33/06 33/064

(54) Abstract Title
Heave compensation system for rough sea drilling

(57) The system comprises a blowout preventer (BOP) 13 above the water line with a first telescopic joint 12 between the BOP 13 and a floating drilling rig 101 and a second telescopic joint 20 installed below the BOP. The upper joint 12 is used to compensate for momentary heave (e.g. wave) motion while the lower joint 20 is used to compensate for heave motions of longer time period (e.g. tides).

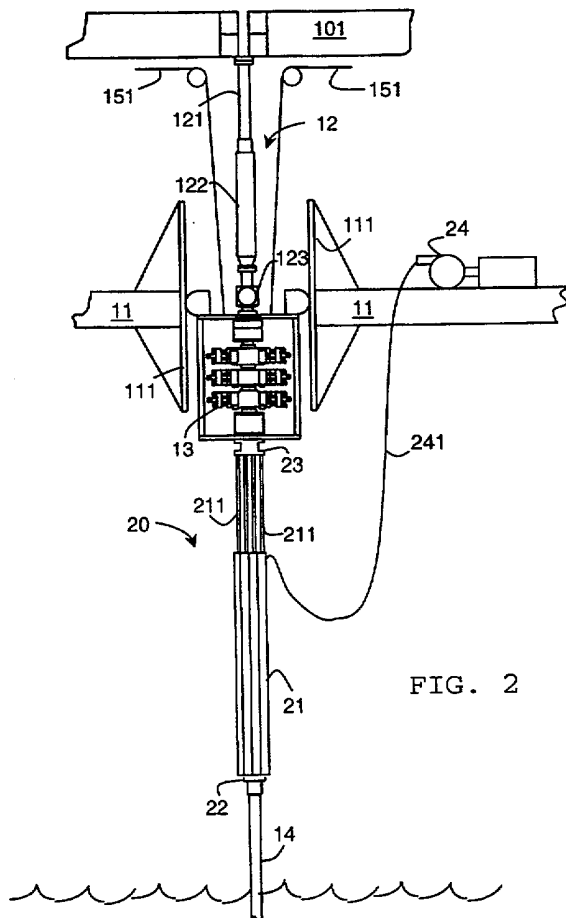

FIG. 2

GB 2 358 032 A

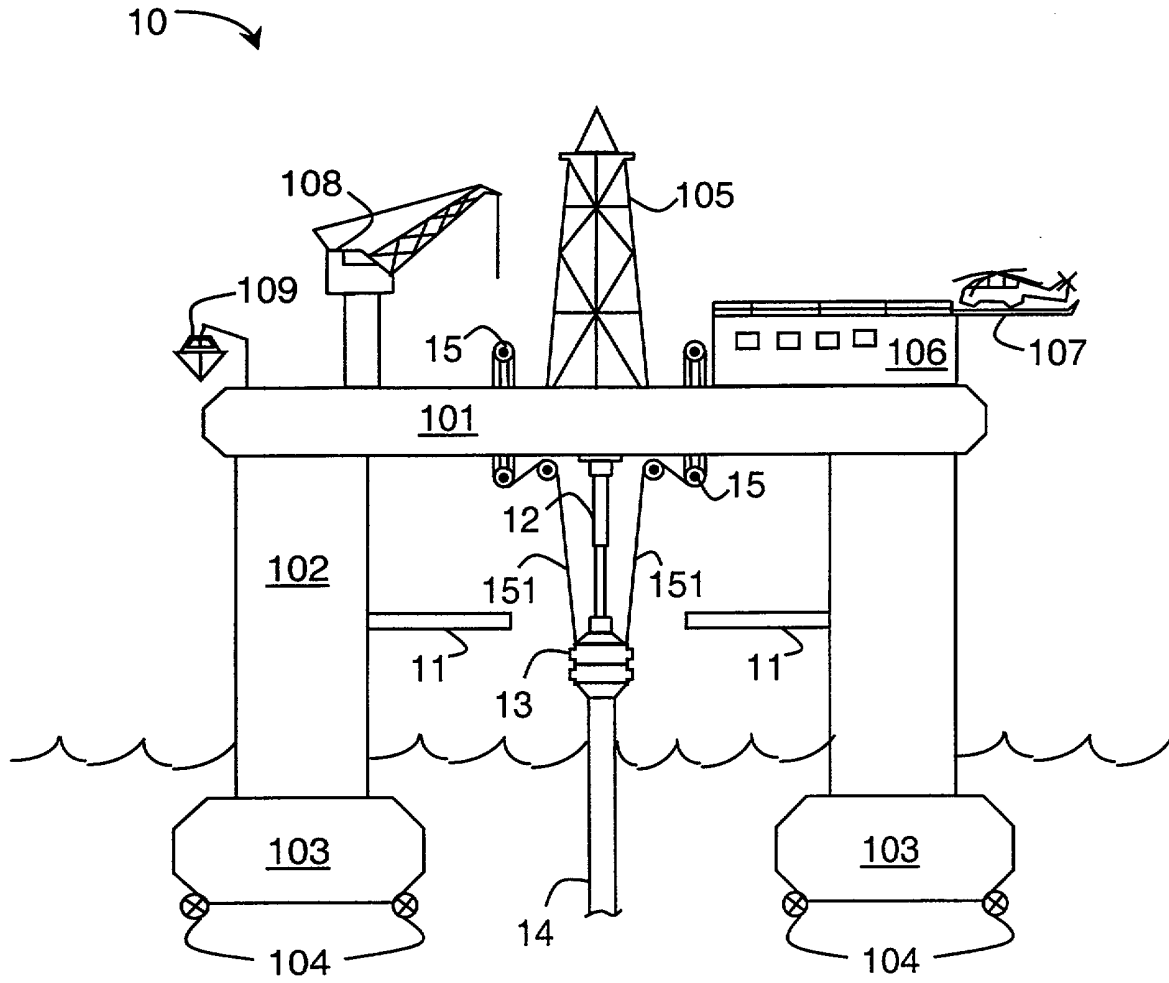

FIG. 1A
(Prior Art)

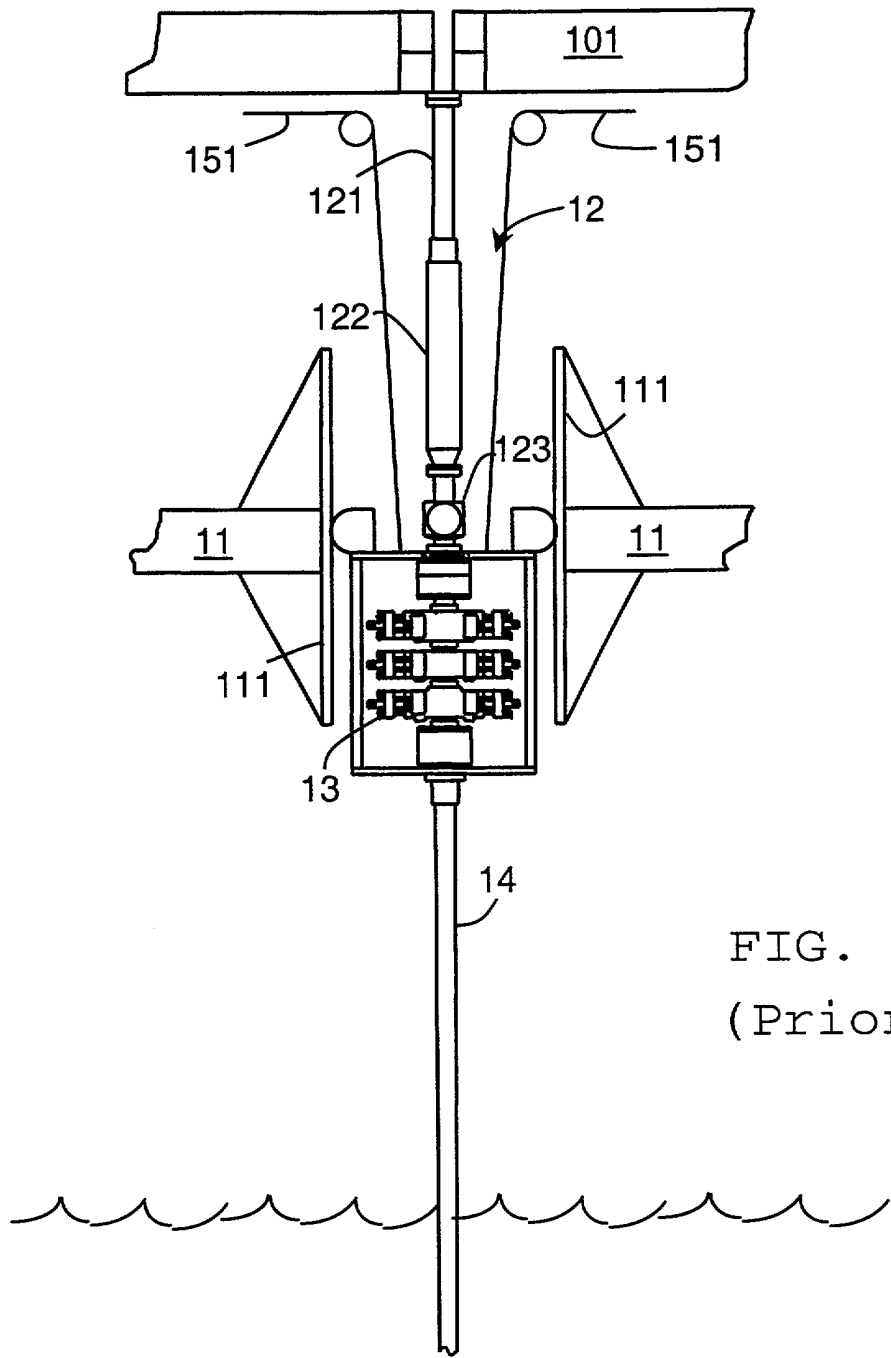

FIG. 1B
(Prior Art)

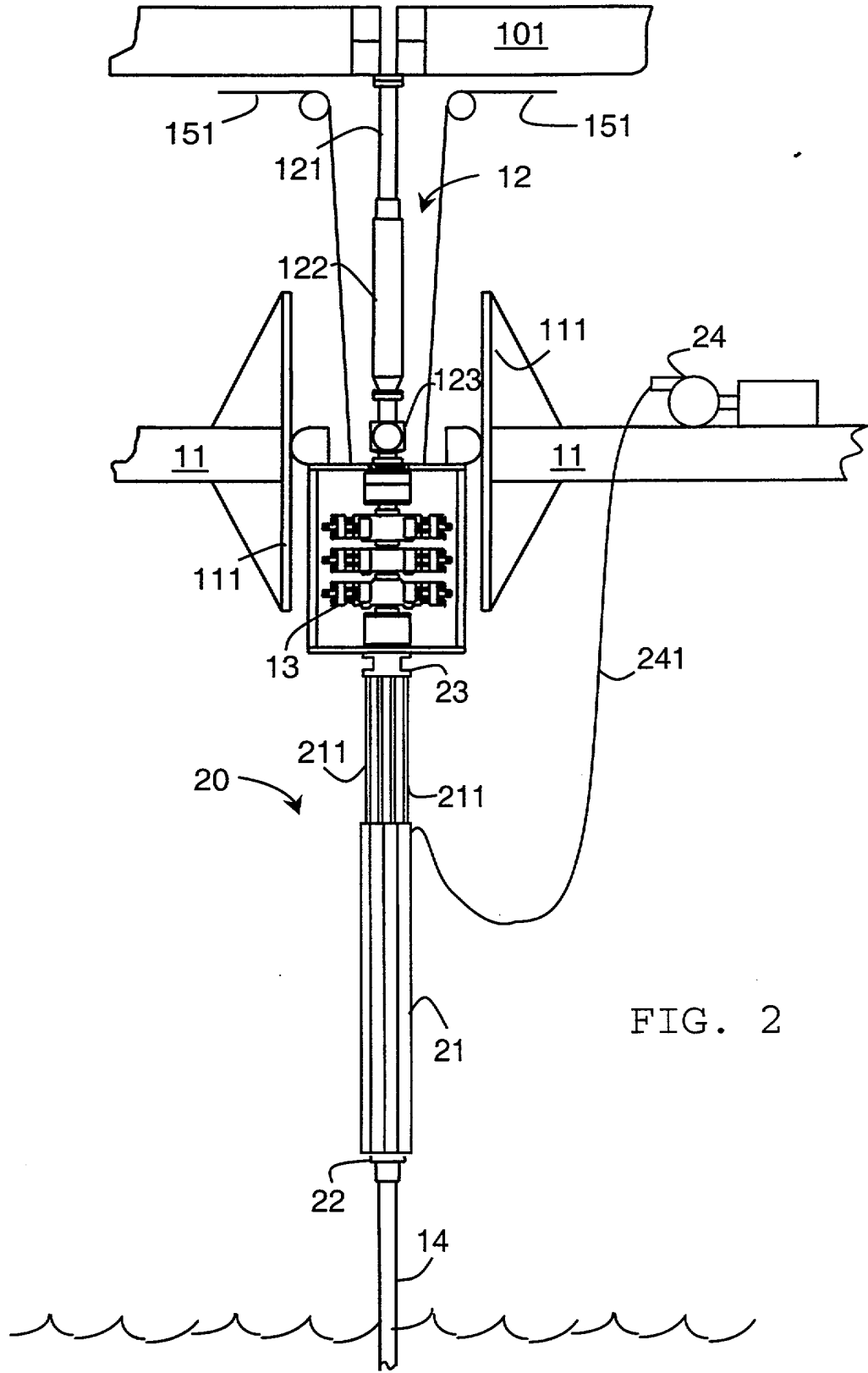

FIG. 2

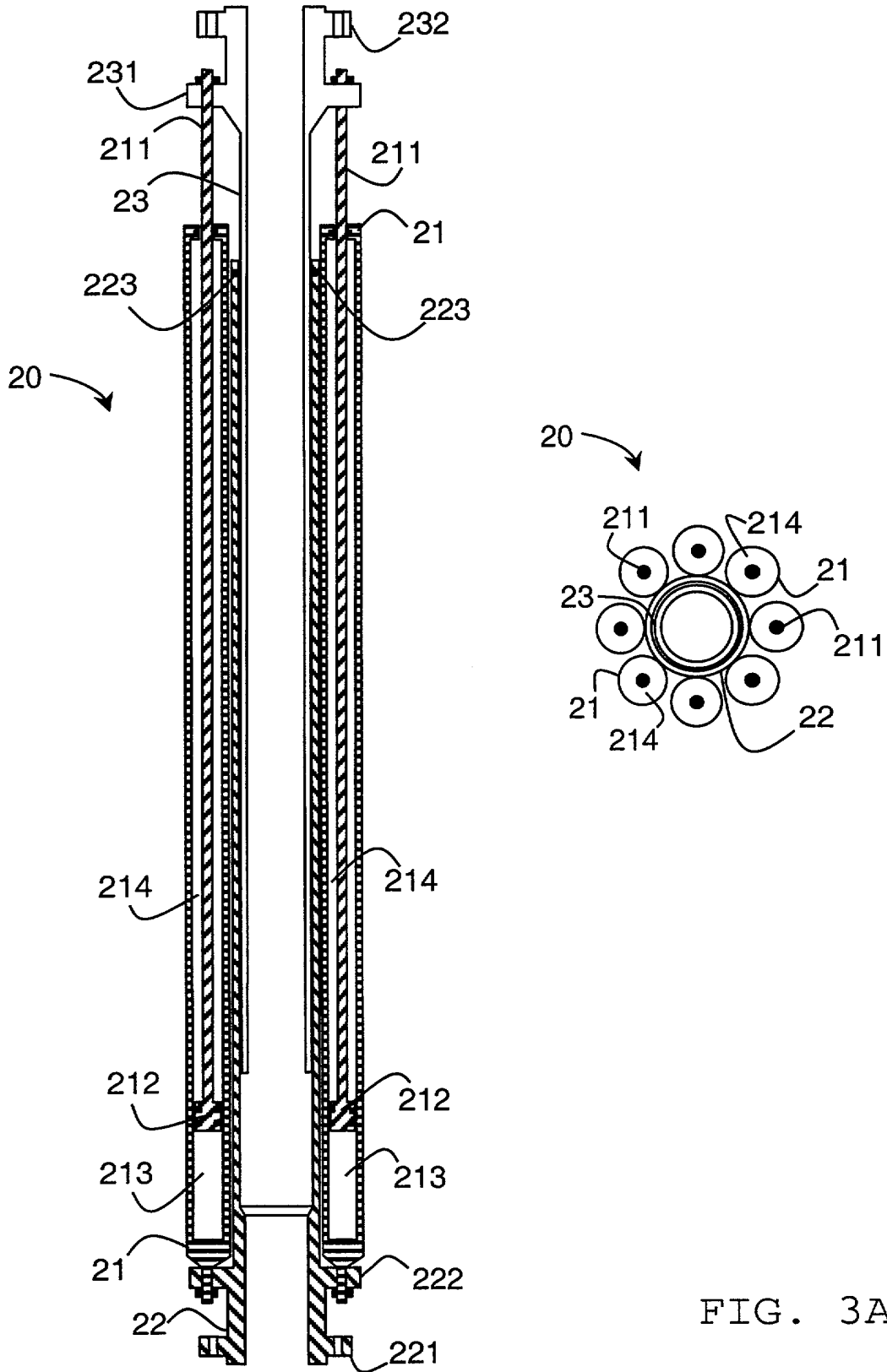

FIG. 3A

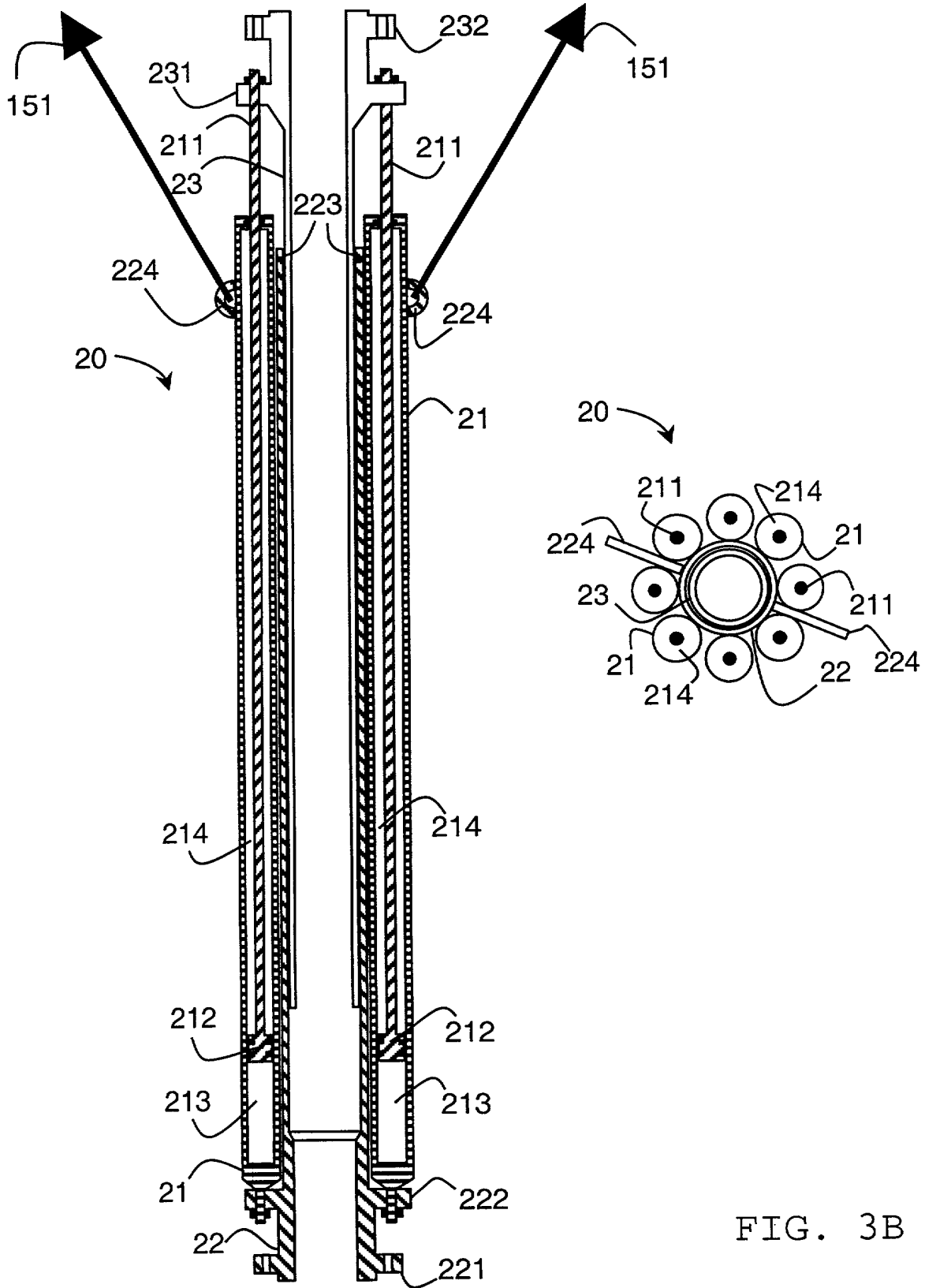

FIG. 3B

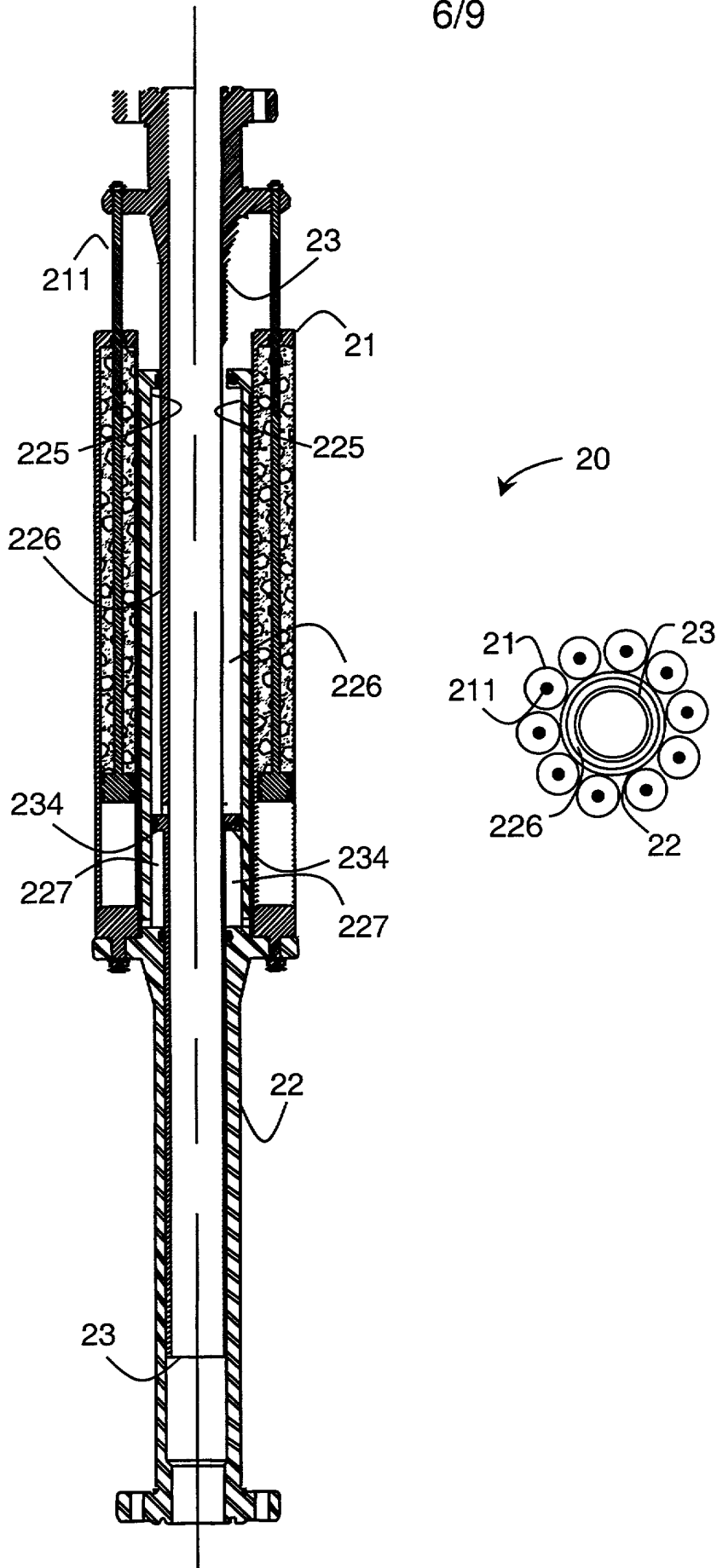

FIG. 4A

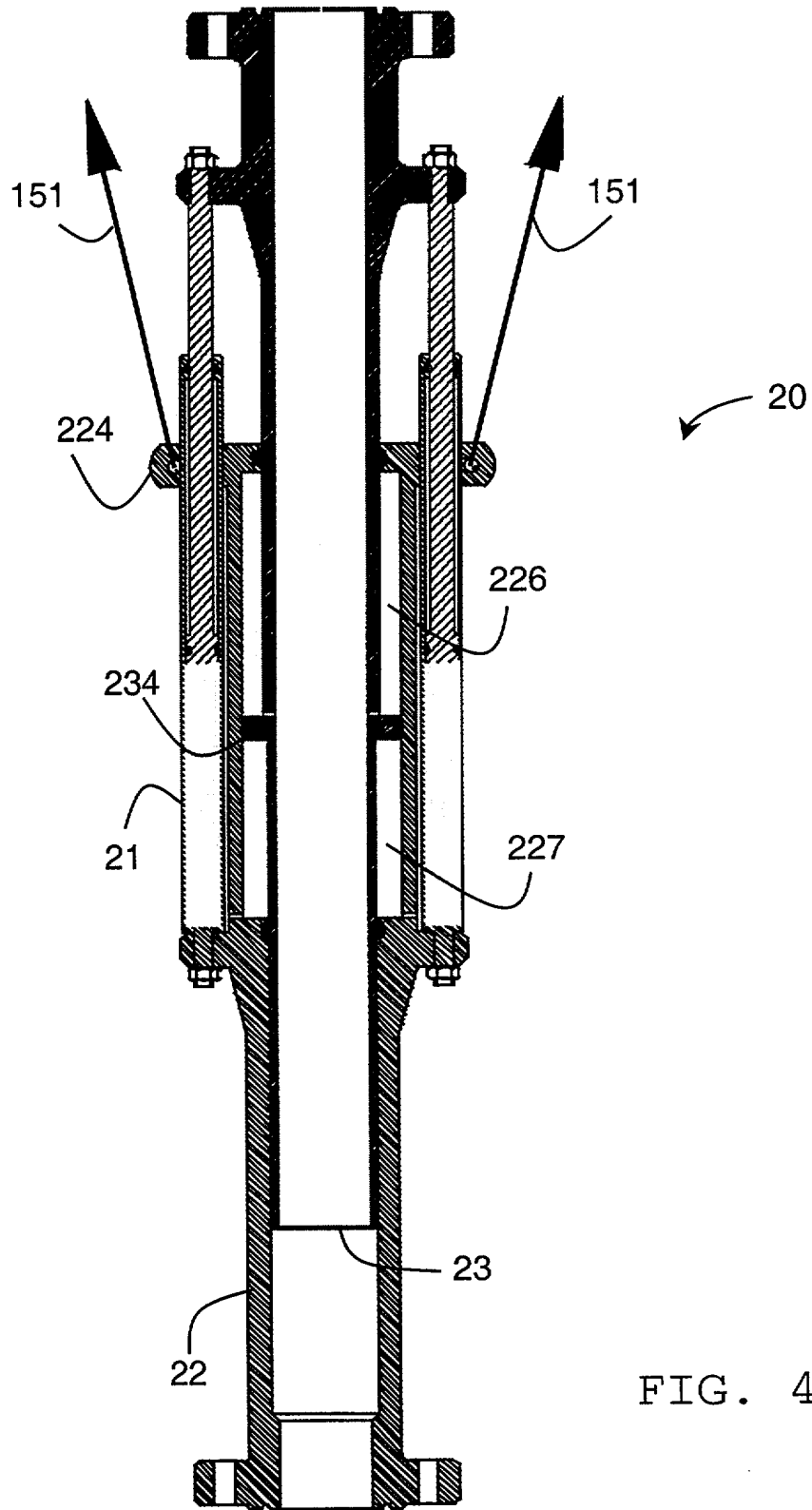
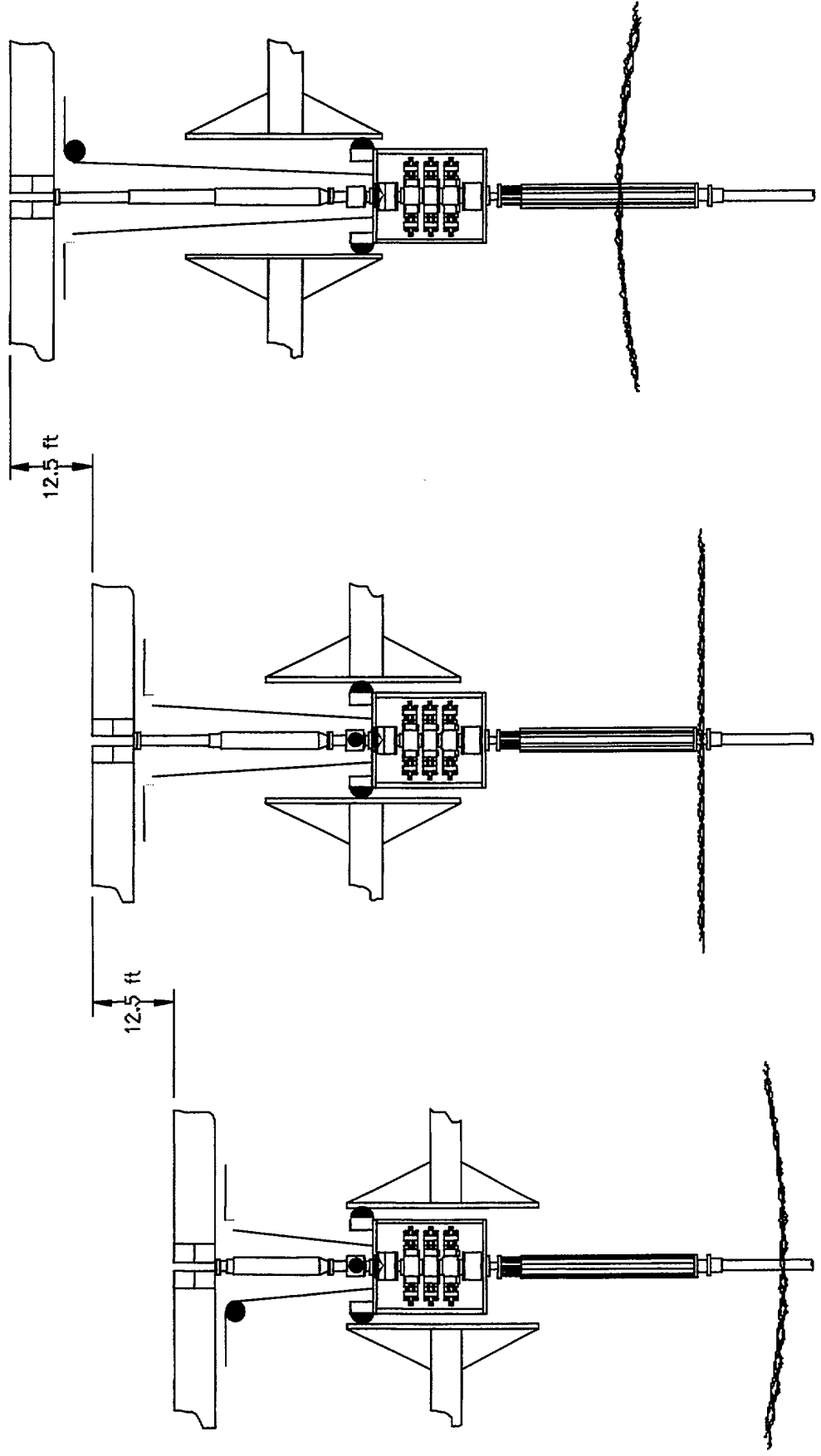

FIG. 4B



Rig heaved fully up

Neutral position

Rig heaved fully down

FIG. 5

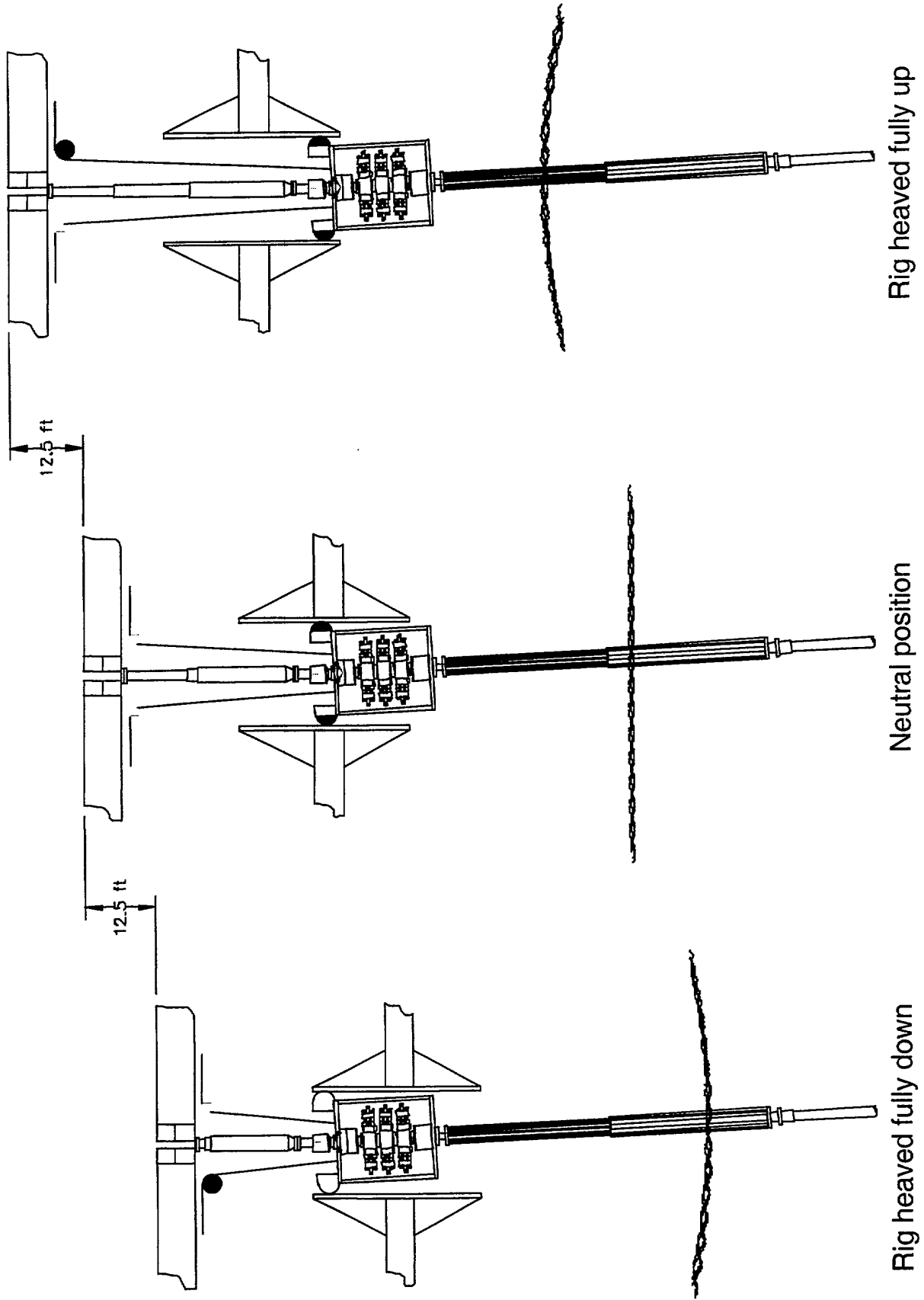

Rig heaved fully up

Neutral position

Rig heaved fully down

FIG. 6

Method and Apparatus for Drilling Subsea Wells

This invention relates to subsea wells, and concerns in particular subsea oil wells and the methods and apparatus by which they are operatively connected to a floating drilling rig positioned on the sea surface above the well head.

BACKGROUND OF THE INVENTION

10 With the maturing of hydrocarbon reserves found and produced onshore using land based rigs and well, there has been considerable attention attracted to the drilling and production of oil and gas wells located in water. In the early period of offshore drilling and in relatively shallow water, wells could
15 be drilled from bottom founded, fixed rigs. Traditionally, jackup rigs consisting of barge-shaped hulls with three or four (sometimes more) structural or tubular legs have been used for shallow water drilling operations.

20 As hydrocarbon exploration and production moves into ever deeper waters, the industry is relying more and more on the use of floating rigs. As used herein, a "floating rig" is any structure that moves vertically (heave motion) with respect to a point on the seabed. Floating rigs include drilling ships and
25 vessels and semisubmersible rigs (semi-subs). Excluded from this definition are other so-called "compliant" platforms such as Tension Leg Platforms (TLP), which are restricted in their reaction to wave and wind forces by load or tension bearing connections pinned to sea floor. Floating rigs respond
30 essentially unrestricted to first order wave forces and rely on a passive spread catenary anchor mooring system or on an active controlled-thruster dynamic positioning system to maintain a relatively steady proximity to a point on the sea floor.

Moving drilling operation to a floating rig requires a major change in the placing of the blowout preventer (BOP) and other equipment connected the BOP, such as wellhead, choke and kill lines, and control systems. Until recently, it was common
5 practice in offshore drilling to place the BOP on the seabed as what is commonly referred to as "subsea" BOP. In case where the pressure inside the well increases suddenly ("kick"), the BOP is activated to rapidly shut the well, i.e., confining the high pressure within the well in order to protect the operating
10 personnel and equipment on the surface.

Conventionally, the required operative connection between the subsea BOP and the drilling rig is effected using a large-bore thick-walled pipe of steel or composite material known as a
15 "riser". The riser has to withstand static loads exerted for example by the its own weight and weight of the drilling mud circulated through it. In water depths above 1000 meters, for example, the volume of the riser begins to exceed the volume of the well. In addition, the riser has to withstand dynamic loads
20 which are typically caused by wave induced forces.

To compensate wave motion, it is known to suspend a support ring below the vessel by constant tension cables in order to keep the riser under tension. A telescopic joint lands in the support
25 ring and connects to a conduit that extends to the vessel. The telescopic joint is often referred to as "slip joint"

The tension is maintained by the mechanical connection between the top of the riser and a number of hydraulic or hydro-
30 pneumatic cylinders maintained under approximately constant pressure by means of an air or air/hydraulic accumulator. The cylinders maintain tension on reeled wire ropes or chains that are reeved around sheaves at the blind and rod ends of each cylinder.

35

The free end of the wire rope or chain is then passed to the outer (or fixed) barrel of the riser slip joint where it is

secured to the support ring. Because of the compensating motion of the tensioner cylinders, the effective length of the rope or chain thus varies with the motion of the platform while maintaining tension on the fixed section of the drilling riser anchored at its lower end to the wellhead.

The inner (or free) barrel of the riser slip joint is fixed to the platform to move vertically with the heave of the platform, barge, or vessel, resulting in a varying length of riser.

While the rope and pulley form of tensioners is the generally accepted technology, various proposals have been made to incorporate a fluid powered heave compensation and tensioner system into the slip joint.

Telescopic joints are for example described in the United States Patents Nos. 4,367,981g; 4,615,542; 5,069,488; 5,727,630, and in the International Patent Application WO 97/43516. In particular '488 describes a pressure and volume balanced design for a hydraulically operated slip joint placed below a BOP permanently placed on the deck of a floating production platform.

Further variants of slip joints are known such as two-stroke telescopic joints with two inner barrel. The two-stroke joint exploits the available travel of the joint slightly better than the conventional one-stroke slip joint, however at the expense of an increased number of seals.

Recent advances in deep water drilling saw the BOP being placed above the water line within the moon pool area of the drilling vessel. The so-called "surface" or "dry" BOP rests on the riser or casing tubulars and is suspended by a tensioner system similar to the one used for seabed BOPs. A slip joint landed on top of the BOP stack compensates wave-induced heave motion.

Current attempts to expand the operational window for the surface BOP technology into geographical areas with rougher seas

are restricted due to a lack of adequate heave compensation. Rougher seas require a heave compensation system with an increased travel compared to the existing systems.

5 To appreciate the problem of increasing travel in the conventional slip joint system, it is worth noting that the slip joint is placed between the BOP and the drill deck of the floating vessel. To lower the position of the BOP would mean a higher risk of submerging the BOP. In order to maintain
10 operability of the BOP under submerged conditions, the operator may be forced to exchange the normal surface ("dry") BOP against a "wet" BOP stack that is designed for subsea operation, thus sacrificing a big economical advantage of the surface BOP technology. On the other hand, it is not possible to raise the
15 height-above-water of the floating drilling vessel without decreasing the stability of the vessel.

To overcome this problem, it has been contemplated to place the slip joint below the BOP and to install the BOP permanently on
20 the floating rig. Placing the slip joint below the BOP, obviously obviates most of the slip joint's travel or stroke limitations. However, a slip joint located below the BOP has to withstand the maximum pressure of the BOP, i.e., requires the same pressure rating as the BOP to prevent failure in a blow-out
25 situation. Even though the above-cited US Patent No 5,069,488 discloses a theoretical high-pressure telescopic joint for a BOP permanently installed on a mobile production platform, the inventor is not aware of any successful implementation of this high pressure slip joint. The problems relating to the
30 implementation of such a high pressure slip joint are at least partly due to the various dynamic loads on the high pressure seals. They must be capable of handling simultaneously high pressure, rapid translation (due to heave) and bending (due to offset, roll and pitch). At present it appears that the industry
35 is not willing to adopt the high pressure slip joint, in spite of its obvious benefits.

It remains therefore a task to provide a technically reliable motion compensation system for rough sea drilling operations while employing surface (dry) BOP stacks and avoiding the use of the expensive subsea rated (wet) BOP equipment.

5

SUMMARY OF THE INVENTION

In accordance with the present invention, there is provided a
10 heave compensating system comprising a high pressure telescopic joint located below the BOP stack combined with a standard low pressure slip joint above the BOP stack.

Underlying the invention is an analysis of the various types of
15 motions of a drilling vessel. A standard slip joint stroke has to allow for the following motions: heave, offset (rig lateral displacement), tides, riser setting height space-out, and subsea latching/unlatching stroke. When considering the nature of these displacements it was noticed that heave is the only truly
20 "dynamic" displacement, with a period of several seconds. The other displacements to be allowed for in the total stroke are either "one-time" adjustments, (space out, latching/unlatching), or of a long periodic nature (tides, offset etc.).

25 The powered telescopic joint, though not capable of compensation all motions of the vessel, would be sufficient to offset the motions of long periodic nature. It can stroke in or out initially to allow for riser setting height. Subsequently it can be adjusted to allow for tides, offset and unlatching. The
30 adjustments would be made in order to place the standard low pressure slip joint in the optimum stroke position to accommodate the heave. Below or above the slip joint would also be the location of the flex joint to handle the bending load.

35 Obviously, the total travel or stroke of the combined high and low pressure telescopic joints can be within limits divided between the two joints. For most cases, a 1:1 distribution of

the total travel is preferred. However, deviations from this ratio might be favorable under particular conditions.

Advantageously, the present motion compensating system is
5 combined with a known riser tensioning system to maintain a constant upwardly pulling force on the riser. It is feasible to have the tensioner system connected to the riser at a point below the high pressure joint. Under these conditions, the high pressure joint would not experience the pulling force of the
10 tensioner. However, in a preferred embodiment of the invention the riser tensioning system is fixed to a point above the high pressure telescopic joint. In this embodiment the travel of the tensioner system is equal the (smaller) travel of the low pressure slip joint.

15

Therefore, while the high pressure powered telescopic joint in accordance with the invention still has to accommodate pressure and some bending, it no longer has to handle high velocity axial reciprocation whilst under pressure. In fact it could
20 alternatively termed "adjustable riser section". Typically, it would be hydraulically powered, and can be mechanically locked in any position. However other means of displacement can be envisaged to set the high pressure telescopic joint, such as rack and pinion drive, linear electric or magneto-electric
25 drives. Control could be manual or automatic taking the BOP/Rig relative positions as input.

The high pressure telescopic joint can be designed as a pressure balanced device or non-balanced. The latter variant is preferred
30 because it simplifies significantly the design of the joint.

In a further preferred embodiment of the present invention, the high pressure joint comprises a plurality of axially reciprocating members arranged around the outer circumference of
35 the riser pipe (or its extension). The reciprocating members can be for example hydraulic cylinders. The advantage of having the load on the high pressure riser distributed over a plurality of

smaller reciprocating members lies in an inherent redundancy of the system. If one or more members fail, e.g., due to the leakage of a seal, the compensation system can still be operated, albeit with a reduced maximum power.

5

These and other features of the invention, preferred embodiments and variants thereof, possible applications and advantages will become appreciated and understood by those skilled in the art from the following detailed description and drawings.

10

DRAWINGS

FIGS. 1A,B illustrate a prior art system for offshore
15 drilling having a BOP suspended at the moon pool level of a drilling rig;

FIG. 2 shows details of a heave compensation system in accordance with the invention;

20

FIGS. 3A,B show design details of two variants of a slip joint to be employed below the BOP in accordance with the novel heave compensation system;

25 FIGS. 4A,B show design details of two variants of a pressure balanced slip joint to be employed in accordance with the novel heave compensation system; and

30 FIGS. 5 and 6 show the novel heave compensation system under various operating conditions.

35

MODE(S) FOR CARRYING OUT THE INVENTION

FIG. 1B shows in simplified format an example of a known floating drilling platform (semi-submersible) as used in surface BOP drilling operations.

The floating rig shown is a twin-hulled column stabilized semi-submersible **10** comprising a deck **101**, columns **102** and two hulls (pontoons) **103**. Attached to the pontoons are thrusters **104** to position the rig relatively to the sea floor. The deck **101** comprises typical installations including the derrick **105**, crew quarters **106**, a helipad **107**, cranes **108** and lifeboats **109**. Below the main deck **101** there is shown a lower deck **11** surrounding the moon pool.

15

The floating rig **10** is connected to a subsea borehole (not shown) via a (low pressure) slip joint **12**, a blow-out preventer (BOP) stack **13** and a marine riser **14**. The riser is kept from buckling by a riser tensioner system comprising pairs of hydraulically separable sheave wheels **15** over which ropes **151** are reeled to pull the riser **14** with a constant upwardly directed force.

20

A more detailed view of the known floating system is shown in FIG. 1B. In FIG. 1B a part of the rig floor **101** is shown. Attached to the bottom of the rig floor is the inner barrel **121** of the low pressure slip joint **12**. The outer barrel **122** of the slip joint is connected at its lower end to a flexible or ball joint **123**. The flex joint is mounted on the BOP stack **13**. The lower end of the BOP lead into the top section of the marine riser **14**. Tensioner ropes **151** are pulling the frame of the BOP stack maintaining the riser under tension. At the level of the moon pool guiding rails **111** are shown that restrict the motion of the BOP **13**. The guiding rails **111** are fixed to the moon pool deck **11**.

30

35

The travel or stroke of the low pressure slip joint is assumed to be 25 ft. Ideally the neutral position of the BOP is set to 12.5 ft of stroke such that the BOP **13** is approximately level with the moon pool deck **11**. It is immediately obvious that increasing the maximum stroke of the slip joint to 50 ft would lower the neutral position of the BOP **13** to 25 ft below the drilling deck **101** and 12.5 ft below the moon pool **11** and hence precariously close to the water line **17**. Any heave compensation would submerge the BOP and may require the exchange of the "dry" rated BOP stack against a more expensive "wet" rated one.

Referring now to FIG. 2, an example in accordance with the present invention is illustrated. It is perhaps best understood when viewed together with FIG.1B. The same reference numerals are used in both figures to denote identical or equivalent elements.

While most elements of FIG. 2 are described above, a high pressure telescopic joint **20** is now introduced between the bottom end of the BOP **13** and the upper part of the riser **14**. The telescopic joint **20** has an array **21** of hydraulic cylinders symmetrically arranged around the outer circumference of its external cylinder or casing **22**. Piston rods **211** are secured at the upper part of the inner cylinder **23** of the telescopic joint **20**.

The array **21** of hydraulic cylinders communicates via a flexible pressure hose **241** with a hydraulic pump **24** located on the moon pool deck **11**.

The ropes **151** of the riser tensioners are fixed to the frame of the BOP **13**. As a consequence, the high pressure telescopic joint

20 has to bear (and balance) the pulling force of the tensioner system.

A conventional slip joint **12** with a flex joint **123** is provided
5 to connect the upper part of the BOP **13** with the drill deck **101**
as described above with reference to FIG. 1B.

By employing the motion compensation system of FIG. 2, the
operator can adjust the relative position of the BOP **13** by means
10 of controlling the pressure of the hydraulic fluid within the
array of hydraulic cylinders **21**. An increase in pressure forces
the piston rods downward and hence closes the telescopic joint
20. Further operating modes of the new motion compensation
system are outlined below, after first describing some possible
15 variants of the telescopic joint **20**.

Referring now to FIG. 3A, the load-bearing variant of the high
pressure telescopic joint is described in greater detail. FIG.
3A shows a vertical and horizontal cross-section through a
20 middle plane of the telescopic joint **20**. The joint has eight
identical hydraulic cylinders **21** arranged symmetrically around
the circumference of the external cylinder **22**. The lower end of
the external cylinder is provided with a connector **221** for
fixing the telescopic joint to the riser. Above the connector
25 **221** is a flange **222** for mounting the hydraulic cylinders **21**.
Engaged with the inner wall of the external cylinder **22** is the
inner cylinder **23** of the telescopic joint. Gliding seals **223** are
provided to enable a pressure sealed sliding motion of the inner
cylinder **23** relative to the outer cylinder **22**. The seals are
30 provided with wipers or flushing devices to minimize
contamination with mud or cuttings of the drilling process.
Mounted on the top end of the inner cylinder **23** is a flange **231**
to secure the piston rods **211** of the hydraulic cylinders **21**.

Located above the flange **231** is a connector **232** adapted to be fixed to the lower end of the BOP stack.

Pistons **212** divide the hydraulic cylinders **21** into a lower chamber or compartment **213** and an upper chamber **214**. The lower chamber **213** is kept at ambient pressure, while the upper chamber **214** is connected to pump **24** that provides pressurized hydraulic fluid.

The present example of the telescopic joint **20** has an inner diameter of 12.4" and an outer diameter (including the hydraulic cylinders **21**) of 46". The hydraulic cylinders **21** are designed with a working pressure of 5,000 psi, which translates into a working pressure of the telescopic joint **20** of 8,000 psi. The tensile load is 1,600 kips. The joint **20** has a closed length of 35 ft and an open length of 60 ft, providing a maximum stroke or travel of 25 ft.

A variant of the above example is shown in FIG. 3B. The high pressure telescopic joint of FIG. 3B differs from the one of FIG. 3A in that the connection points **224** of the ropes **151** of the riser tensioner have been moved from the BOP frame to the external cylinder **22** of the telescopic joint. Hence the upwardly directed pulling force is acting directly onto the riser, thus relieving the strain on the joint and its hydraulic system.

The FIGS 4A and 4B illustrate pressure balanced variants of the telescopic joints of FIGS 3A and 3B, i.e., in a load-bearing and a non-load-bearing embodiment, respectively.

In a pressure balanced joint the internal pressure is neutralized resulting in a net zero force on the inner cylinder **23**, regardless of the internal pressure.

To achieve this balance, the external cylinder **22** has a wider section (bore) **225** providing a pressure sealed annular compartment. The outer wall of the internal cylinder **23** forms the inner wall of compartment. An annular sealed flange **234** acts
5 as a piston dividing the compartment into an upper chamber **226** and a lower chamber **227**. The upper chamber **226** communicates with the interior of the joint through bores located directly above the flange **234**. Hence, the pressure within the upper chamber **226** equals the pressure within the riser pipe. Bores through the
10 wall of the external cylinder at the bottom level of the lower chamber **227** ensure that the lower chamber is kept at ambient pressure.

To balance the pressure in the telescopic joint the effective
15 area of the flange **234** is made equal the cross-sectional area of the internal cylinder.

An array of ten hydraulic cylinders **21** is arranged around the circumference of the external cylinder **22** of the high pressure
20 telescopic joint. The design and function of those ten cylinders is identical to the hydraulic cylinders described in the examples above (FIG. 3A).

A variant of the pressure-balanced variant of FIG 4A is
25 illustrated by FIG. 4B. The new variant is not load-bearing. Similar to the example of FIG. 3B, riser ropes **151** are attached to the external cylinder **22** of the telescopic joint **20**. The other features of this variant are identical to those described with reference to FIG. 4A above.

30 The remaining FIGs. 5 and 6 illustrate how the two joints can be operated.

In FIG. 5 it is assumed that the high pressure telescopic joint is fully closed, e.g. at low tide. The heave motion caused by the waves is compensated by the slip joint above the BOP. The center drawing of FIG. 5 shows the slip joint in its neutral position. The drawing to the left and right illustrate the rig fully heaved down and up respectively. It should be noted that during the short period of the heave, the state of the high pressure telescopic joint is not altered.

10 In FIG. 6 it is assumed that the high pressure telescopic joint is fully expanded, e.g. at high tide. Additionally the rig is at its maximum offset from the wellbore tilting the riser and BOP. The slip joint above the BOP again solely compensates the heave motion caused by the waves. As above, the center drawing of FIG 15 5 shows the slip joint in its neutral position. The drawing to the left and right illustrate the rig fully heaved down and up respectively. Again, during the short period of the heave, the state of the high pressure telescopic joint is not altered.

20 Between the two extremes of FIGs. 5 and 6, that is between the left hand drawing of FIG. 5 and the right hand drawing of FIG. 6, the rig moved by 50 ft with respect to the wellbore.

CLAIMS

1. A heave compensating apparatus for a floating drilling rig;
comprising
5 a conduit section of extendable length adapted to be located above a blow-out preventer stack; and
a further conduit of extendable length adapted to be located below said blow-out preventer stack.
- 10 2. A heave compensating apparatus according to claim 1 comprising a blow-out preventer stack rated to withstand a blowout pressure and being under operational conditions installed within a conduit system extending from the
floating drilling rig into a subsea wellbore, said conduit
15 system enabling the circulation of drilling fluids from said floating rig into said wellbore and back to the surface, wherein said blow-out preventer stack is under operational conditions located above the water line.
- 20 3. A heave compensating apparatus according to claim 1, wherein an extension of the extendable conduit above the blow-out preventer is independent of the extension of the extendable conduit below the blow-out preventer stack.
- 25 4. A heave compensating apparatus according to claim 1, the extendable conduit above the blow-out preventer is adapted to extend or contract with heave motions of the rig having a short time period and the extendable conduit below the blow-out preventer stack is adapted to extend or contract
30 with heave motions of the vessel having a long time period.
5. A heave compensating apparatus according to claim 1, wherein the extendable conduit above the blow-out preventer is adapted to expand and contract in accordance with a
35 momentary position of the floating rig with respect to the

seabed while the length of the extendable conduit below the blow-out preventer is maintained for finite time intervals.

6. A heave compensating apparatus according to claim 1,
5 wherein the extendable conduit below the blow-out preventer stack is a telescopic joint rated at the blowout pressure of the blow-out preventer stack and associated with a power source adapted to provide energy to actively set said extendible conduit at a predetermined length.
- 10
7. A heave compensating apparatus according to claim 1, comprising a tensioner system capable of maintaining conduits between the floating rig and a well bore at seabed level under constant tension and a power source adapted to
15 provide energy to actively set the extendable conduit section below the blowout preventer stack at a predetermined length.
8. A heave compensating apparatus according to claim 1,
20 wherein the extendable conduit located below the blowout preventer stack comprises an inner cylinder, an external cylinder and a plurality of reciprocating members arranged around the outer circumference of external cylinder.
- 25 9. A heave compensating apparatus according to claim 1, wherein the extendable conduit located below the blowout preventer stack comprises an inner cylinder, an external cylinder, a girding sealing system between said inner and said outer cylinder and a plurality of hydraulic cylinders
30 circumferentially arranged around the external cylinder and having piston rods attached to a flange of the inner cylinder.

10. A heave compensating apparatus according to claim 1,
wherein the extendable conduit above the blow-out preventer
stack is a slip joint.
- 5 11. A method of compensating heave while operating a floating
drilling rig; comprising the steps of
mounting a conduit section of extendable length above a
blow-out preventer stack; and
mounting a further conduit of extendable length below said
10 blow-out preventer stack.
12. A heave compensating method according to claim 11, wherein
a momentary length of the extendable conduit above the
blow-out preventer is adjusted independently of a momentary
15 length of the extendable conduit below the blow-out
preventer stack.
13. A heave compensating method according to claim 11, further
comprising the steps of constantly adjusting the length of
20 the extendable conduit above the blow-out preventer with
heave motions of the rig having with a short time period
while setting the length the extendable conduit below the
blow-out preventer stack in accordance with a predetermined
heave height and maintaining said length for a longer time
25 period.
14. A heave compensating method according to claim 11, using a
tensioner system to maintain conduits between the floating
rig and a well bore at seabed level under constant tension
30 and a power source to actively set the extendable conduit
section below the blowout preventer stack at a
predetermined length.



17

Application No: GB 0000006.7
Claims searched: 1 - 14

Examiner: David Hotchkiss
Date of search: 23 February 2000

**Patents Act 1977
Search Report under Section 17**

Databases searched:

UK Patent Office collections, including GB, EP, WO & US patent specifications, in:
UK Cl (Ed.R): E1F (FAY, FJA, FJB, FJG)
Int Cl (Ed.7): E21B
Other: Online: WPI; EPODOC; PAJ

Documents considered to be relevant:

Category	Identity of document and relevant passage	Relevant to claims
Y	US3917006 A (Smith International Inc.) Whole document especially figures 1 and 3	1, 10 & 11
Y	US 5069488 A (Smedvig IPR AS) Whole document especially figure 1	1, 2, 10 & 11
Y	WO 98/58152 A (Morvan, Pierre) Whole document	1, 2, 10 & 11

X	Document indicating lack of novelty or inventive step	A	Document indicating technological background and/or state of the art.
Y	Document indicating lack of inventive step if combined with one or more other documents of same category.	P	Document published on or after the declared priority date but before the filing date of this invention.
&	Member of the same patent family	E	Patent document published on or after, but with priority date earlier than, the filing date of this application.