

(12) STANDARD PATENT APPLICATION (11) Application No. AU 2015207853 A1
(19) AUSTRALIAN PATENT OFFICE

(54) Title
External steerable fiber for use in endoluminal deployment of expandable devices

(51) International Patent Classification(s)
A61F 2/97 (2013.01) **A61F 2/95** (2013.01)

(21) Application No: **2015207853** (22) Date of Filing: **2015.07.28**

(43) Publication Date: **2015.08.20**

(43) Publication Journal Date: **2015.08.20**

(62) Divisional of:
2012337259

(71) Applicant(s)
W. L. Gore & Associates, Inc.

(72) Inventor(s)
Bloss, Roberta A.;Burkart, Dustin C.;Norris, Patrick M.;Sondreaal, Matthew G.;Walsh, Stephanie M.

(74) Agent / Attorney
Griffith Hack, GPO Box 1285, Melbourne, VIC, 3001

ABSTRACT

The present disclosure describes treatment of the vasculature of a patient with an expandable implant. The implant is constrained to a reduced delivery diameter for delivery within the vasculature by at least one sleeve. The implant can be constrained to other diameters, such as an intermediate diameter. The sleeves can be expanded, allowing for expansion of the diameter of the expandable implant, by disengaging a coupling member from the sleeve or sleeves from outside of the body of the patient. The expandable implant can comprise a steering line or lines which facilitate bending and steering of the expandable implant through the vasculature of a patient.

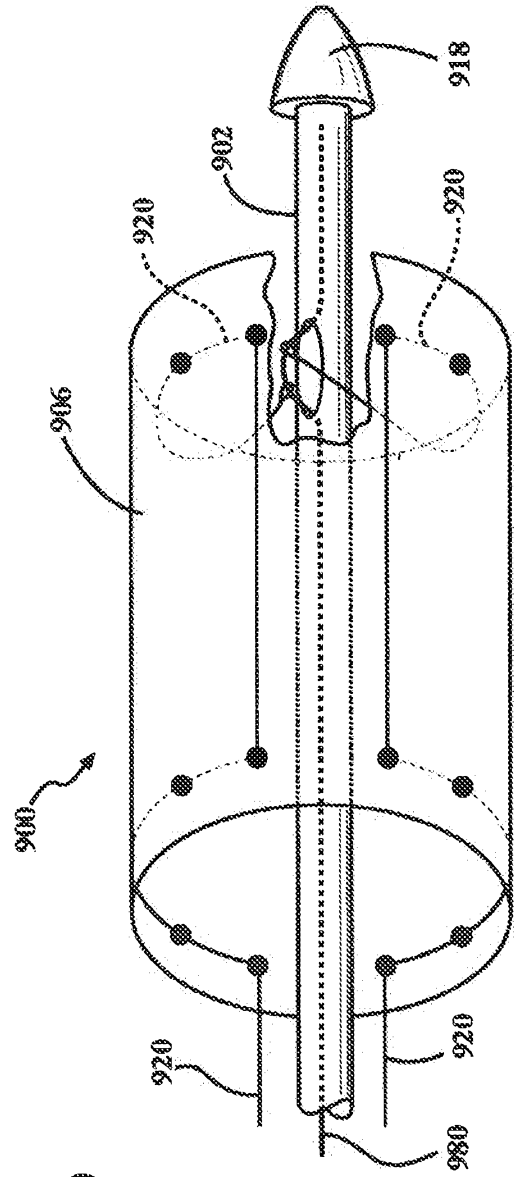
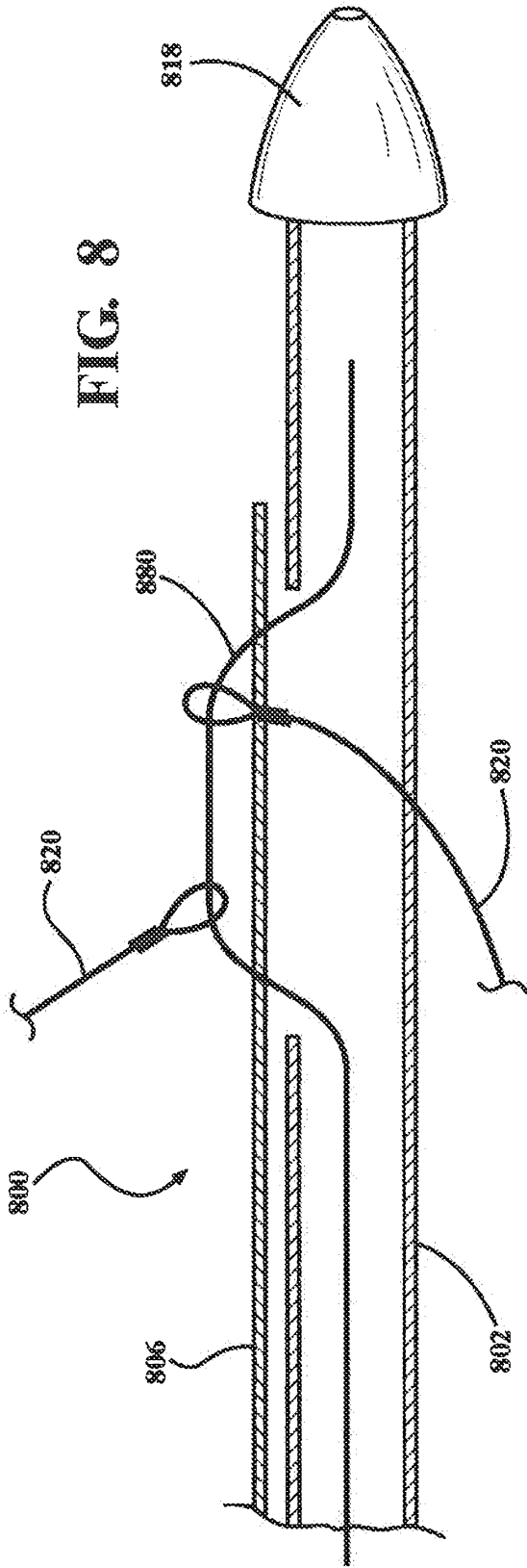

EXTERNAL STEERABLE FIBER FOR USE IN ENDOLUMINAL DEPLOYMENT OF EXPANDABLE DEVICES

CROSS-REFERENCE TO RELATED APPLICATIONS

[0001] This application is a divisional application of Australian application No. 2012337259, the disclosure of which is incorporated herein by reference.

BACKGROUND

Field

[0002] The present disclosure relates generally to endoluminal devices and, more specifically, to steering expandable endoluminal devices within the vasculature of a patient.

Discussion of the Related Art

[0003] Endoluminal therapies typically involve the insertion of a delivery catheter to transport an implantable prosthetic device into the vasculature through a small, often percutaneous, access site in a remote vessel. Once access to the vasculature is achieved, the delivery catheter is used to mediate endoluminal delivery and subsequent deployment of the device via one of several techniques. In this fashion, the device can be remotely implanted to achieve a therapeutic outcome. In contrast to conventional surgical therapies, endoluminal treatments are distinguished by their “minimally invasive” nature.

[0004] Expandable endoluminal devices can be comprised of a graft or a stent component with or without a graft covering over the stent interstices. They can be designed to expand when a restraint is removed or to be balloon-expanded from their delivery diameter, through a range of intermediary diameters, up to a maximal, pre-determined functional diameter. The endoluminal delivery and deployment of expandable endoluminal devices pose several unique problems. For example, the endoluminal device itself must be constrained in a suitable introductory size (or delivery diameter) to allow insertion into the vasculature and mounted onto a delivery device such as a catheter shaft. In such configurations, the endoluminal devices can be difficult to navigate through vasculature that has significant bending or curvature.

[0005] Therefore, it is desirable to provide systems for endoluminal delivery of expandable endoluminal devices to vascular treatment sites, particularly along tortuous vasculature, such as along the aortic arch.

SUMMARY OF THE INVENTION

[0006] The invention provides a catheter assembly comprising: a catheter having a leading end and a trailing end and comprising a main lumen extending between the leading end and the trailing end; an expandable device positioned at the leading end of the catheter, the expandable device having a proximal end and a distal end, a collapsed configuration for endoluminal delivery of the expandable device to a treatment site, and an expanded configuration having a diameter larger than the diameter of the collapsed configuration; a steering line extending through the main lumen of the catheter and disposed within at least a portion of and extending longitudinally along the expandable device to allow selective longitudinal bending of the expandable device, wherein the steering line torsionally anchors the expandable device and the catheter allowing rotational positioning of device at the treatment site via rotation of the catheter.

[0007] In some embodiments, the catheter may further comprise a primary sleeve wrapped circumferentially around the expandable device, the primary sleeve comprising a sheet of material having a first major surface and a second major surface and a plurality of openings extending from the first major surface to the second major surface; a primary coupling member cooperating with the plurality of openings for releasably coupling portions of the sheet to one another to constrain the expandable device in the collapsed configuration.

[0008] In some embodiment, the catheter may further comprise a secondary sleeve and secondary coupling member, wherein the secondary sleeve limits the expansion of the expandable device to an intermediate configuration having a diameter larger than the diameter of the collapsed configuration and smaller than the diameter of the expanded configuration.

BRIEF DESCRIPTION OF THE DRAWINGS

[0009] The accompanying drawings are included to provide a further understanding of the disclosure and are incorporated in and constitute a part of

this specification, illustrate embodiments of the disclosure and together with the description serve to explain the principles of the disclosure, wherein:

[0010] Figure 1 illustrates a side view of a catheter assembly having an expandable implant;

[0011] Figures 2A and 2B illustrate perspective views of catheter assemblies having expandable implants;

[0012] Figures 3A-3B and 3C-3D illustrate cross-sectional and perspective views, respectively, of catheter assemblies having expandable implants;

[0013] Figure 4 illustrates various profile views of a distal end of an expandable implant;

[0014] Figures 5A-5D illustrate perspective views of a catheter assembly having an expandable implant;

[0015] Figure 6 illustrates a perspective view of an expandable implant;

[0016] Figures 7A-7H illustrate cross-sectional views of an expandable implant and sleeve with steering fibers;

[0017] Figure 8 illustrates a cross-sectional view of catheter assembly having an expandable implant; and

[0018] Figure 9 illustrates a side view of a catheter assembly having an expandable implant.

DETAILED DESCRIPTION OF THE ILLUSTRATED EMBODIMENTS

[0019] Persons skilled in the art will readily appreciate that various aspects of the present disclosure can be realized by any number of methods and apparatuses configured to perform the intended functions. Stated differently, other methods and apparatuses can be incorporated herein to perform the intended functions. It should also be noted that the accompanying drawing figures referred to herein are not all drawn to scale, but can be exaggerated to illustrate various aspects of the present disclosure, and in that regard, the drawing figures should not be construed as limiting.

[0020] Throughout this specification and in the claims, the term “distal” refers to a location that is, or a portion of an endoluminal device (such as a stent-graft) that when implanted is, further downstream with respect to blood flow than

another portion of the device. Similarly, the term “distally” refers to the direction of blood flow or further downstream in the direction of blood flow.

[0021] The term “proximal” refers to a location that is, or a portion of an endoluminal device that when implanted is, further upstream with respect to blood flow than another portion of the device. Similarly, the term “proximally” refers to the direction opposite to the direction of blood flow or upstream from the direction of blood flow.

[0022] With further regard to the terms proximal and distal, and because the present disclosure is not limited to peripheral and/or central approaches, this disclosure should not be narrowly construed with respect to these terms. Rather, the devices and methods described herein can be altered and/or adjusted relative to the anatomy of a patient.

[0023] Throughout this specification and in the claims, the term “leading” refers to a relative location on a device which is closer to the end of the device that is inserted into and progressed through the vasculature of a patient. The term “trailing” refers to a relative location on a device which is closer to the end of the device that is located outside of the vasculature of a patient.

[0024] In various embodiments, a catheter assembly is disclosed which utilizes one or more flexible sleeves that (i) releasably constrain an expandable implant, such as an expandable endoluminal stent graft, in a dimension suitable for endoluminal delivery of the implant to a treatment site, such as a vascular member in a patient’s body; and (ii) further constrain the implant to an outer peripheral dimension that is larger than the dimension suitable for endoluminal delivery but smaller than an unconstrained or fully deployed outer peripheral dimension, thereby facilitating selective axial and/or rotational positioning of the implant at the treatment site prior to full deployment and expansion of the implant.

[0025] Various embodiments of the present disclosure comprise a catheter assembly configured to deliver an expandable implant to a treatment area of the vasculature of a patient. In accordance with embodiments of the disclosure, the catheter assembly includes at least one steering line. The steering line (or lines) allows for selective bending of the expandable implant within the vasculature.

[0026] With initial reference to FIG. 1, a catheter assembly 100 in accordance with the present disclosure comprises a catheter shaft 102, a main

lumen 103 and an expandable implant 106. Expandable implant 106 can comprise any endoluminal device suitable for delivery to the treatment area of a vasculature. Such devices can include, for example, stents, grafts, and stent grafts.

[0027] In various embodiments, expandable implant 106 comprises a stent graft. Conventional stent grafts are designed to dilate from their delivery diameter, through a range of intermediary diameters, up to a maximal, pre-determined functional diameter, and generally comprise one or more stent components with one or more graft members displaced over and/or under the stent.

[0028] In various embodiments, expandable implant 106 comprises one or more stent components made of nitinol and a graft member made of ePTFE. However, and as discussed below, any suitable combination of stent component(s) and graft member(s) is within the scope of the present disclosure.

[0029] For example, stent components can have various configurations such as, for example, rings, cut tubes, wound wires (or ribbons) or flat patterned sheets rolled into a tubular form. Stent components can be formed from metallic, polymeric or natural materials and can comprise conventional medical grade materials such as nylon, polyacrylamide, polycarbonate, polyethylene, polyformaldehyde, polymethylmethacrylate, polypropylene, polytetrafluoroethylene, polytrifluoroethylene, polyvinylchloride, polyurethane, elastomeric organosilicon polymers; metals such as stainless steels, cobalt-chromium alloys and nitinol and biologically derived materials such as bovine arteries/veins, pericardium and collagen. Stent components can also comprise bioresorbable materials such as poly(amino acids), poly(anhydrides), poly(caprolactones), poly(lactic/glycolic acid) polymers, poly(hydroxybutyrates) and poly(orthoesters). Any expandable stent component configuration which can be delivered by a catheter is in accordance with the present disclosure.

[0030] Moreover, potential materials for graft members include, for example, expanded polytetrafluoroethylene (ePTFE), polyester, polyurethane, fluoropolymers, such as perfluorelastomers and the like, polytetrafluoroethylene, silicones, urethanes, ultra high molecular weight polyethylene, aramid fibers, and combinations thereof. Other embodiments for a graft member material can include high strength polymer fibers such as ultra high molecular weight

polyethylene fibers (e.g., Spectra®, Dyneema Purity®, etc.) or aramid fibers (e.g., Technora®, etc.). The graft member can include a bioactive agent. In one embodiment, an ePTFE graft includes a carbon component along a blood contacting surface thereof. Any graft member which can be delivered by a catheter is in accordance with the present disclosure.

[0031] In various embodiments, a stent component and/or graft member can comprise a therapeutic coating. In these embodiments, the interior or exterior of the stent component and/or graft member can be coated with, for example, a CD34 antigen. Additionally, any number of drugs or therapeutic agents can be used to coat the graft member, including, for example heparin, sirolimus, paclitaxel, everolimus, ABT-578, mycophenolic acid, tacrolimus, estradiol, oxygen free radical scavenger, biolimus A9, anti-CD34 antibodies, PDGF receptor blockers, MMP-1 receptor blockers, VEGF, G-CSF, HMG-CoA reductase inhibitors, stimulators of iNOS and eNOS, ACE inhibitors, ARBs, doxycycline, and thalidomide, among others.

[0032] In various embodiments, expandable implant 106 can comprise a radially collapsed configuration suitable for delivery to the treatment area of the vasculature of a patient. Expandable implant 106 can be constrained in a radially collapsed configuration and mounted onto a delivery device such as catheter shaft 102. The diameter of the expandable implant 106 in the collapsed configuration is small enough for the implant to be delivered through the vasculature to the treatment area. In various embodiments, the diameter of the collapsed configuration is small enough to minimize the crossing profile of catheter assembly 100 and reduce or prevent tissue damage to the patient. In the collapsed configuration, the expandable implant 106 can be guided by catheter shaft 102 through the vasculature.

[0033] In various embodiments, expandable implant 106 can comprise a radially expanded configuration suitable for implanting the device in the treatment area of a patient's vasculature. In the expanded configuration, the diameter of expandable implant 106 can be approximately the same as the vessel to be repaired. In other embodiments, the diameter of expandable implant 106 in the expanded configuration can be slightly larger than the vessel to be treated to provide a traction fit within the vessel.

[0034] In various embodiments, expandable implant 106 can comprise a self-expandable device, such as a self-expandable stent graft. Such devices dilate from a radially collapsed configuration to a radially expanded configuration when unrestrained. In other embodiments, expandable implant 106 can comprise a device that is expanded with the assistance of a secondary device such as, for example, a balloon. In yet other embodiments, catheter assembly 100 can comprise a plurality of expandable implants 106. The use of a catheter assembly with any number of expandable implants is within the scope of the present disclosure.

[0035] Various medical devices in accordance with the disclosure comprise a sleeve or multiple sleeves. The sleeve or sleeves can constrain an expandable implant device in a collapsed configuration for endoluminal delivery of the implant to a treatment portion of the vasculature of a patient. For the purposes of the disclosure, the term “constrain” can mean (i) to limit the expansion, either through self-expansion or assisted by a device, of the diameter of an expandable implant or (ii) to cover or surround but not otherwise restrain an expandable implant (e.g., for storage or biocompatibility reasons and/or to provide protection to the expandable implant and/or the vasculature). For example, catheter assembly 100 comprises sleeve 104. Sleeve 104 surrounds and constrains expandable implant 106 to a reduced diameter.

[0036] After delivery of the expandable implant to the treatment portion of the vasculature of the patient, the sleeve or sleeves can be unconstrained in order to allow the expandable implant to expand to its functional diameter and achieve the desired therapeutic outcome. In various embodiments, the sleeve or sleeves can remain implanted while not interfering with the expandable implant. In other embodiments, the sleeve or sleeves can be removed from the body of the patient after successful deployment of the expandable implant.

[0037] In various embodiments, an expandable implant is constrained by a single sleeve which circumferentially surrounds the expandable implant. For example, with reference to FIG. 2B, catheter assembly 200 comprises a sleeve 204. In various embodiments, sleeve 204 circumferentially surrounds expandable implant 206 and constrains it in a collapsed configuration, in which the diameter is less than the diameter of the unconstrained implant. For example, sleeve 204 can

constrain expandable implant 206 in a collapsed configuration for delivery within the vasculature.

[0038] In other embodiments, an expandable implant is constrained by a plurality of sleeves which circumferentially surround the expandable implant. The plurality of sleeves can comprise at least two sleeves which circumferentially surround each other.

[0039] In various embodiments, sleeves can be tubular and serve to constrain an expandable implant. In such configurations, sleeves are formed from a sheet of one or more materials wrapped or folded about the expandable implant. While the illustrative embodiments herein are described as comprising one or more tubular sleeves, sleeves of any non-tubular shape that corresponds to an underlying expandable implant or that are otherwise appropriately shaped for a given application are also within the scope of the present disclosure.

[0040] In various embodiments, sleeves are formed by wrapping or folding the sheet of material(s) such that two parallel edges of the sheet are substantially aligned. Said alignment can or cannot be parallel to or coaxial with the catheter shaft of a catheter assembly. In various embodiments, the edges of the sheet of material(s) do not contact each other.

[0041] In various embodiments, the edges of the sheet of material(s) do contact each other and are coupled with a coupling member (as described below) an adhesive, or the like. In various other embodiments, the edges of the sheet of material(s) are aligned so that the edges of the same side of the sheet or sheets (e.g., the front/first major surface or back/second major surface of the sheet) are in contact with each other. In still other embodiments, the edges of opposite sides of the sheet of material(s) are in contact with each other, such that the edges overlap each other, such that a portion of one side of the sheet is in contact with a portion of the other side. Said another way, the front of the sheet can overlap the rear of the sheet, or vice versa.

[0042] In various embodiments, sleeves comprise materials similar to those used to form a graft member. For example, a precursor flexible sheet used to make the sleeve can be formed from a flattened, thin wall ePTFE tube. The thin wall tube can incorporate "rip-stops" in the form of longitudinal high strength fibers attached or embedded into the sheet or tube wall.

[0043] The sheet of material(s) used to form the sleeve(s) can comprise a series of openings, such that the openings extend from one edge of the sheet to the other. In such configurations, a coupling member can be woven or stitched through the series of openings in the sheet of material(s), securing each of the two edges together and forming a tube. For example, in FIG. 1, coupling member 124 secures the edges of sleeve 104 such that sleeve 104 maintains expandable implant 106 in a reduced diameter.

[0044] In various embodiments, the coupling member can comprise a woven fiber. In other embodiments, the coupling member can comprise a monofilament fiber. Any type of string, cord, thread, fiber, or wire which is capable of maintaining a sleeve in a tubular shape is within the scope of the present disclosure.

[0045] In various embodiments, a single coupling member can be used to constrain the diameter of one or more sleeves. In other embodiments, multiple coupling members can be used to constrain the diameter of one or more sleeves.

[0046] In various embodiments, once a suitable expandable implant is in a collapsed configuration, the expandable implant can be deployed within the vasculature of a patient. An expandable implant in a collapsed configuration can be introduced to a vasculature and directed by a catheter assembly to a treatment area of the vasculature. Once in position in the treatment area of the vasculature, the expandable implant can be expanded to an expanded configuration.

[0047] In various embodiments, when the expandable implant is in position within the vasculature, the coupling member or members can be disengaged from the sleeve or sleeves from outside of the body of the patient, which allows the sleeve(s) to open and the expandable implant to expand. As discussed above, the expandable implant can be self-expanding, or the implant can be expanded by a device, such as a balloon.

[0048] The coupling member or members can be disengaged from the sleeve or sleeves by a mechanical mechanism operated from outside of the body of the patient. For example, the member or members can be disengaged by applying sufficient tension to the member or members. In another example, a dial or rotational element can be attached to the coupling member or members outside

of the body. Rotation of the dial or rotational element can provide sufficient tension to, displace and disengage the coupling member or members.

[0049] In other configurations, coupling member or members can be disengaged by non-mechanical mechanisms, such as, for example, dissolution, by providing ultrasonic energy. In such configurations, sufficient ultrasonic energy is provided to coupling member or members to disengage them from the sleeve or sleeves.

[0050] In various embodiments, disengaging a single coupling member which closes a single sleeve from the sleeve allows the expandable device to be expanded. For example, with reference to FIG. 2A, catheter assembly 200 can be used to deliver an implant expandable implant 206 to a treatment area of a vasculature. Expandable implant 206 has a collapsed diameter for delivery, and sleeve 204 circumferentially surrounds expandable implant 206 and is held closed by coupling member 224. As described in more detail below, bending of expandable implant 206 can be controlled prior to full expansion (e.g., at an intermediate diameter) to help facilitate delivery to the desired position. Once expandable implant 206 is in position relative to the treatment area, coupling member 224 is disengaged from sleeve 204 and sleeve 204 is released, allowing expandable implant 206 to expand to a larger diameter.

[0051] As mentioned above, in various embodiments of the present disclosure, an expandable implant can further comprise an intermediate configuration. In the intermediate configuration, the diameter of the expandable implant is constrained in a diameter smaller than the expanded configuration and larger than the collapsed configuration. For example, the diameter of the expandable device in the intermediate configuration can be about 50% of the diameter of the expandable device in the expanded configuration. However, any diameter of the intermediate configuration which is less than the diameter of the expanded configuration and larger than the collapsed configuration is within the scope of the invention.

[0052] In such embodiments, the expandable implant can be expanded from the collapsed configuration to the intermediate configuration once the implant has been delivered near the treatment area of the vasculature of a patient. The

intermediate configuration can, among other things, assist in properly orienting and locating the expandable implant within the treatment area of the vasculature.

[0053] In various embodiments, an expandable implant can be concentrically surrounded by two sleeves having different diameters. In such configurations, a primary sleeve constrains the expandable implant in the collapsed configuration. Once the collapsed configuration sleeve is opened, a secondary sleeve constrains the expandable implant in the intermediate configuration. As discussed above, the expandable implant can be self-expanding, or the implant can be expanded by a device, such as a balloon.

[0054] For example, with reference to FIG. 2A, a catheter assembly 200 comprises an expandable implant 206 and sleeve 204. Secondary sleeve 204 constrains expandable implant 206 to an intermediate configuration. Secondary sleeve 204 is held in position around expandable implant 206 by secondary coupling member 224.

[0055] Catheter assembly 200 further comprises primary sleeve 208, which constrains expandable implant 206 in a collapsed configuration for delivery to the vasculature of a patient. Primary sleeve 208 is held in position around expandable implant 206 by primary coupling member 234.

[0056] Once expandable implant 206 is sufficiently close to the treatment area of the vasculature, primary coupling member 234 is disengaged from primary sleeve 208, which releases primary sleeve 208 and allows expanded implant 206 to expand to a larger diameter.

[0057] With reference to FIG. 2B, after primary sleeve 208 has been expanded, secondary sleeve 204 constrains the expandable implant 206 in the intermediate configuration. In the intermediate configuration, as mentioned above and as described in more detail below, expandable implant 206 can be oriented and adjusted (e.g., by bending and torsional rotation) to a desired location within the treatment area of the vasculature.

[0058] In other embodiments of the present disclosure, a single sleeve can be used to constrain the expandable implant in both a collapsed configuration and an intermediate configuration. For example, with reference to FIGS. 3A-3D, catheter assembly 300 comprises an expandable implant 306, a monosleeve 304, a primary coupling member 334, and a secondary coupling member 324.

[0059] Monosleeve 304 further comprises a plurality of secondary holes 332. In this configuration, secondary coupling member 324 is stitched or woven through secondary holes 332, constricting monosleeve 304 and expandable implant 306 to the diameter of an intermediate configuration. In the intermediate configuration, the diameter of expandable implant 306 is less than the expanded diameter and larger than the diameter of the collapsed configuration. In the intermediate configuration, as described in more detail below, expandable implant 306 can be oriented and adjusted (e.g., by bending and torsional rotation) to a desired location within the treatment area of the vasculature.

[0060] Monosleeve 304 further comprises a plurality of primary holes 330. In this configuration, primary coupling member 334 is stitched or woven through primary holes 330, constricting monosleeve 304 and expandable implant 306 to the diameter of the collapsed configuration. The diameter of the collapsed configuration is selected to allow for delivery of the expandable implant 306 to the treatment area of the vasculature of a patient.

[0061] Once expandable implant 306 has been delivered to a region near the treatment area of the vasculature, primary coupling member 334 can be disengaged from monosleeve 304, allowing expandable implant 306 to be expanded to the intermediate configuration. Expandable implant 306 can be oriented and adjusted (e.g., by bending and torsionally rotating) to a desired location within the treatment area of the vasculature. After final positioning, secondary coupling member 324 can be disengaged from monosleeve 304, and expandable implant 306 can be expanded to the expanded configuration.

[0062] Although a number of specific configurations of constraining members (for example, primary and secondary members) and sleeves (for example, primary and secondary sleeves) have been discussed, the use of any number and/or configuration of constraining members and any number of sleeves is within the scope of the present disclosure.

[0063] In various embodiments, the catheter assembly further comprises a steering line. In such configurations, tension can be applied to the steering line to displace the steering line and bend the expandable implant. In various embodiments, the degree of bending of the expandable device relative to the catheter assembly is proportional to the amount of displacement of the steering

line. Bending the expandable implant can, among other things, allow the implant to conform to curvatures in the vasculature of a patient. It can also assist in travelling through curved regions of vasculature.

[0064] For example, with reference to FIGS. 2A-2B, steering line 220 passes from the outside of the body of a patient, through catheter shaft 202, and is releasably coupled to expandable implant 206. In such configurations, steering line 220 can be threaded through expandable implant 206 such that tension applied to steering line 220 from outside of the body of the patient causes expandable implant 206 to bend in a desired manner.

[0065] As a further example, with reference to FIG. 6, an expandable implant 606 is illustrated. Steering line 620 is threaded along the surface of expandable implant 606.

[0066] In various embodiments, steering line 220 can comprise metallic, polymeric or natural materials and can comprise conventional medical grade materials such as nylon, polyacrylamide, polycarbonate, polyethylene, polyformaldehyde, polymethylmethacrylate, polypropylene, polytetrafluoroethylene, polytrifluorochlorethylene, polyvinylchloride, polyurethane, elastomeric organosilicon polymers; metals such as stainless steels, cobalt-chromium alloys and nitinol. Further, steering line 220 can also be formed from high strength polymer fibers such as ultra-high molecular weight polyethylene fibers (e.g., Spectra®, Dyneema Purity®, etc.) or aramid fibers (e.g., Technora®, etc.). However, any material that can be used to bend and/or steer an expandable implant is within the scope of the present disclosure.

[0067] With reference to FIGS. 7A-H, cross-sectional views of various expandable implant configurations are illustrated. In various embodiments, an expandable implant can comprise a stent 705 and a graft member 707, which are surrounded by sleeve 704. In such configurations, a steering line 720 can be threaded through stent 705, graft member 707, and/or sleeve 704 in a variety of different patterns. Such patterns can, among other benefits, facilitate the bending of the expandable implant by applying tension to (and corresponding displacement of) steering line 720 from outside of the body. Further, such patterns can reduce or prevent steering line 720 from damaging tissue within the vasculature of the patient by limiting or preventing “bowstringing.” Bowstringing occurs when a string

or thread travels in a direct line between two points on the inside of a curve in an expandable graft. This can cause the string or thread to come into contact with and potentially damage tissue in the vasculature. Bowstringing and its effects on tissue can also be reduced and/or minimized by sleeve 704 as sleeve 704 surrounds steering line 720 during bending and prior to full expansion of the expandable implant.

[0068] As illustrated in FIGS. 7B-7H, steering line 720 can be woven through any combination of stent 705, graft member 707, and sleeve 704. In each figure described below, a segment of a pattern is described. A steering line can be woven between a stent, graft member, and sleeve in any combination of these patterns. Alternatively, the steering line can interact with an expandable implant and one or more sleeves in any manner which allows steering line 720 to bend the expandable implant in a desired manner.

[0069] In FIG. 7B, steering line 720 is threaded between the inner wall of sleeve 704 and stent 705. In FIG. 7C, steering line 720 passes between a first apex 751 of stent 705 and the outer wall of graft member 707, passes between second apex 752 and the inner wall of sleeve 704, extends into and through the wall of graft member 707, reenters graft member 707, passes between a third apex 753 of stent 705 and the inner wall of sleeve 704, and passes between a fourth apex 754 and the inner wall of sleeve 704. In FIG. 7D, steering line 720 passes between first apex 751 and the outer wall of graft member 707, then between second apex 752 and the inner wall of sleeve 704.

[0070] In FIG. 7E, steering line 720 passes between first apex 751 and the outer wall of graft member 707, extends through the outer wall of graft member 707, reenters graft member 707, and passes between third apex 753 and the outer wall of graft member 707. In FIG. 7F, steering line 720 passes between the outside wall of graft member 707 and stent 705.

[0071] In FIG. 7G, steering line 720 passes from the inner wall of graft member 707, through to the outer wall of graft member 707 between first apex 751 and second apex 752, back through to the outer wall of graft member 707, and back through to the inner wall of graft member 707 between third apex 753 and fourth apex 754. In FIG. 7H, steering line 720 is disposed against the inner wall of graft member 707. As discussed previously, FIGS. 7B-7G illustrate

example patterns in which a steering line can interact with an expandable implant. Any way in which a steering line interacts with an expandable implant to facilitate bending of the implant is within the scope of the present disclosure.

[0072] In various embodiments, a catheter assembly can comprise more than one steering line. For example, with reference to FIG 9, catheter assembly 900 comprises two steering lines 920. As described in relation to FIGS. 7A-7G, steering lines 920 can be woven through the surface of expandable implant 906. In various embodiments, steering lines 920 can exit catheter shaft 902 and engage expandable implant 906 near the proximal end of expandable implant 906. In such configurations, steering lines 920 can travel across and remain substantially in contact with the surface of expandable implant 906 from the proximal end to the distal end. Steering lines 920 can then disengage the surface of expandable implant 906 and become secured to catheter assembly 900. However, multiple steering lines 920 can interface with any portion of expandable implant 906, including the proximal end, the distal end, and any portion between the two ends.

[0073] In various embodiments, steering lines 920 traverse and interact with the surface of expandable implant 906 in a pattern which facilitates controllable bending of expandable implant 906. For example, as illustrated in FIG. 9, steering lines 920 can traverse the surface of expandable implant 906 such that, across a significant portion of expandable implant 906, both steering lines 920 are parallel to and in close proximity with each other. Such a configuration allows the tension applied to steering lines 920 to work together to form a bend or curvature in the same segment of expandable implant 906. Any configuration of steering lines 920 and surface of expandable implant 906 which allows for selective and controllable bending of expandable implant 906 is within the scope of the present disclosure.

[0074] In various embodiments, steering lines can traverse a path across and/or through the surface of expandable implant that is at least partially parallel to and substantially covered by one or more sleeves.

[0075] In various embodiments, the catheter assembly can further comprise a lock wire. In such embodiments, the lock wire can secure a steering line or lines to the catheter assembly. For example, with reference to FIG. 8, catheter assembly 800 comprises a catheter shaft 802, expandable implant 806, two

steering lines 820, and a lock wire 880. Lock wire 880 passes from outside of the body of the patient, through catheter shaft 802. Lock wire 880 exits a side port of the catheter shaft 802, engages steering lines 820, then reenters catheter shaft 802 and continues to catheter tip 818. In such a configuration, lock wire 880 releasably couples steering lines 820 to catheter assembly 800. Any manner in which lock wire 880 can interact with steering line or lines 820 to maintain a releasable coupling between steering line or lines 820 and catheter assembly 800 is within the scope of the present disclosure.

[0076] In various embodiments, each steering line can further comprise an end loop. For example, with reference to FIG. 9, each steering line 920 comprises an end loop 922. Lock wire 980 can pass through each end loop 922, securing each steering line 920 to catheter assembly 900. Any method of securing steering line or lines 920 to catheter assembly 900 is within the scope of the invention.

[0077] In various embodiments, lock wire 980 can be formed from metallic, polymeric or natural materials and can comprise conventional medical grade materials such as nylon, polyacrylamide, polycarbonate, polyethylene, polyformaldehyde, polymethylmethacrylate, polypropylene, polytetrafluoroethylene, polytrifluoroethylene, polyvinylchloride, polyurethane, elastomeric organosilicon polymers; metals such as stainless steels, cobalt-chromium alloys and nitinol. Further, lock wire 980 can also be formed from high strength polymer fibers such as ultra-high molecular weight polyethylene fibers (e.g., Spectra®, Dyneema Purity®, etc.) or aramid fibers (e.g., Technora®, etc.). Any material that can provide sufficient engagement with and secure steering line 920 to catheter assembly 900 is within the scope of the present disclosure.

[0078] In various embodiments, a catheter assembly used to deliver an expandable implant comprises a catheter shaft, an expandable implant, one or more sleeves, one or more steering lines, and a lock wire. In such configurations, the expandable implant is capable of bending, through tension applied to the one or more steering lines and corresponding displacement, to conform to curvature in the vasculature of a patient.

[0079] For example, with reference to FIGS. 5A-D, a catheter assembly 500 comprising an expandable implant 506 is illustrated. Catheter assembly 500 further comprises two steering lines 520, a lock wire 580, a primary coupling

member 524, and a secondary coupling member 534. Primary coupling member 524 is releasably coupled to primary sleeve 504. Secondary coupling member 534 is releasably coupled to secondary sleeve 508.

[0080] Catheter assembly 500 is inserted into the vasculature of a patient, and expandable implant 506 is advanced to a treatment area of the vasculature. Upon arriving at a location close to the treatment area, primary coupling member 524 can be disengaged from primary sleeve 504, allowing expandable implant 506 to be expanded to an intermediate configuration. In various embodiments, sleeve 504 can be removed from the vasculature once primary coupling member 524 has been disengaged.

[0081] With reference to FIG. 5B, upon expansion to an intermediate configuration, tension can be applied to steering lines 520, causing expandable implant 506 to bend in a desired manner. For example, expandable implant 506 can bend in a direction aligned with the location of steering lines 520. Once expandable implant 506 has been sufficiently bent, consistent tension is applied to steering lines 520 to maintain the degree of bending.

[0082] In various embodiments, tension can be applied to steering lines 520 by pulling the lines from the outside of the body of the patient. In other embodiments, steering lines 520 can be connected to a one more dials or other mechanisms for applying the tension at the trailing end of catheter shaft 502. In this configuration, the dial can be used to apply a desired tension, as well as maintain the correct amount of tension once a desired angle of bending of expandable implant 506 has been achieved. Various embodiments can also comprise an indicator, scale, gradient, or the like which demonstrates the amount of tension or displacement of the steering line, and/or the amount of bending in expandable implant 506. In various embodiments, the catheter assembly can comprise one more additional markings (e.g., on a handle) that allow a user to determine the orientation of the steering line with respect to the vasculature.

[0083] After a sufficient degree of bending has been achieved in expandable implant 506, the implant can be rotated for final positioning in the treatment area of the vasculature. In various exemplary embodiments, lock wire 580 is engaged with steering lines 520 such that torsional rotation of the catheter shaft causes expandable implant 506 to rotate within the vasculature. However,

any configuration of catheter assembly 500 which allows for rotation of expandable implant 506 is within the scope of the present disclosure.

[0084] In various embodiments, an expandable implant can further comprise one or more radiopaque markers. In one embodiment, one or more radiopaque markers form a band around the distal end of the expandable implant. In other embodiments, one or more radiopaque markers can be embedded in a sleeve, such as a primary sleeve or a secondary sleeve. Further, one or more radiopaque markers can be embedded in a catheter shaft. In these configurations, the radiopaque markers can assist in deployment of an expandable implant by providing increased visibility when observing the expandable implant with a radiographic device, such as an x-ray machine. Any arrangement of radiopaque markers which assists in deployment of an expandable implant is within the scope of the present disclosure.

[0085] In various embodiments, radiopaque markers can assist in orienting the expandable implant by providing a profile view of the distal or proximal end of the expandable implant. For example, with reference to FIG. 4, a number of potential profiles 491-495 of the distal and/or proximal end of an expandable implant 406 are illustrated. In such configurations, radiopaque markers located in the distal and/or proximal end of expandable implant 406 provide a profile view of the end of expandable implant 406 when viewed by a radiographic device. Such profile views can be used to properly orient expandable implant 406 by assisting a user in determining the degree of rotation and/or orientation of a bend in expandable implant 406.

[0086] For example, profile 491 represents a distal end of an expandable implant 406 having an orientation substantially orthogonal to a radiographic image capture device, such as an x-ray camera. Profile 492 represents a distal end of an expandable implant having an orientation less orthogonal than profile 491. Profile 493 represents a distal end of an expandable implant 406 having an orientation less orthogonal than profile 492. Finally, profile 494 represents a distal end of an expandable implant 406 having an orientation parallel to a radiographic image capture device.

[0087] After expandable implant 506 has been properly oriented and located within the treatment area of the patient, secondary coupling member 534

can be disengaged from secondary sleeve 508. Once secondary coupling member 534 is disengaged from secondary sleeve 508, expandable implant 506 can be expanded to a final position and diameter within the treatment area. In various exemplary embodiments, secondary sleeve 508 is removed from the vasculature. In other exemplary embodiments, secondary sleeve 508 remains in position circumferentially surrounding a portion of expandable implant 506.

[0088] With reference to FIG. 5C, after expandable implant 506 is in position and expanded within the vasculature, lock wire 580 can be disengaged from catheter assembly 500. In various embodiments, lock wire 580 is disengaged by applying sufficient tension from outside of the body of the patient. After lock wire is disengaged, steering lines 520 can be released from coupling with catheter shaft 502 and can be removed from expandable implant 506 and catheter assembly 500.

[0089] As illustrated in FIG. 5D, after primary and secondary coupling members 524 and 534, steering lines 520, and lock wire 580 are removed from catheter assembly 500, catheter assembly 500 is fully disengaged from expandable implant 506, and can be removed from the vasculature of the patient.

[0090] It will be apparent to those skilled in the art that various modifications and variations can be made in the present disclosure without departing from the spirit or scope of the disclosure. Thus, it is intended that the present disclosure cover the modifications and variations of this disclosure provided they come within the scope of the appended claims and their equivalents.

[0091] Likewise, numerous characteristics and advantages have been set forth in the preceding description, including various alternatives together with details of the structure and function of the devices and/or methods. The disclosure is intended as illustrative only and as such is not intended to be exhaustive. It will be evident to those skilled in the art that various modifications can be made, especially in matters of structure, materials, elements, components, shape, size and arrangement of parts including combinations within the principles of the disclosure, to the full extent indicated by the broad, general meaning of the terms in which the appended claims are expressed. To the extent that these various modifications do not depart from the spirit and scope of the appended claims, they are intended to be encompassed therein.

[0092] It is to be understood that, if any prior art publication is referred to herein, such reference does not constitute an admission that the publication forms a part of the common general knowledge in the art, in Australia or any other country.

[0093] In the claims which follow and in the preceding description of the invention, except where the context requires otherwise due to express language or necessary implication, the word "comprise" or variations such as "comprises" or "comprising" is used in an inclusive sense, i.e. to specify the presence of the stated features but not to preclude the presence or addition of further features in various embodiments of the invention.

THE CLAIMS DEFINING THE INVENTION ARE AS FOLLOWS:

1. A catheter assembly comprising:
 - a catheter having a leading end and a trailing end and comprising a main lumen extending between the leading end and the trailing end;
 - an expandable device positioned at the leading end of the catheter, the expandable device having a proximal end and a distal end, a collapsed configuration for endoluminal delivery of the expandable device to a treatment site, and an expanded configuration having a diameter larger than the diameter of the collapsed configuration; and
 - a steering line extending through the main lumen of the catheter and disposed within at least a portion of and extending longitudinally along the expandable device to allow selective longitudinal bending of the expandable device, wherein the steering line torsionally anchors the expandable device and the catheter allowing rotational positioning of the device at the treatment site via rotation of the catheter.

2. The catheter assembly of claim 1, further comprising a primary sleeve wrapped circumferentially around the expandable device, the primary sleeve comprising a sheet of material having a first major surface and a second major surface and a plurality of openings extending from the first major surface to the second major surface; and
 - a primary coupling member cooperating with the plurality of openings for releasably coupling portions of the sheet to one another to constrain the expandable device in the collapsed configuration.

3. The catheter assembly of claim 2, further comprising a secondary sleeve and a secondary coupling member, wherein the secondary sleeve limits the expansion of the expandable device to an intermediate configuration having a diameter larger than the diameter of the collapsed configuration and smaller than the diameter of the expanded configuration.

4. The catheter assembly of any one of claims 1 to 3, wherein the expandable device comprises a stent graft.

5. The catheter assembly of claim 4, wherein the stent graft comprises at least one apex, and wherein the steering line is woven through the at least one apex of the stent graft.
6. The catheter assembly of any one of claims 1 to 5, wherein the steering line is removable.
7. The catheter assembly of any one of claims 1 to 6, further comprising a lock wire extending through the main lumen, wherein the lock wire releasably engages the steering line and couples the steering line to the catheter.
8. The catheter assembly of claim 3, wherein the steering line is disposed within the secondary sleeve such that when the catheter assembly is inserted into a vessel, the steering line does not directly contact tissue within the vessel.
9. The catheter assembly of any one of claims 1 to 8, wherein the expandable device is bendable more than about 90 degrees relative to an axis of the catheter.
10. The catheter assembly of any one of claims 1 to 9, wherein a degree of bending of the expandable device relative to an axis of the catheter is proportional to an amount of tension on the steering line.
11. The catheter assembly of any one of claims 1 to 10, wherein the expandable device substantially maintains a desired degree of bending while the expandable device is deployed to the expanded configuration.
12. The catheter assembly of any one of claims 1 to 11, wherein the steering line is connected at one of the proximal end and the distal end of the expandable device.

13. The catheter assembly of claim 3, wherein the secondary coupling member comprises a first-secondary coupling member and a second-secondary coupling member, wherein the first -secondary coupling member is threaded along approximately half of a length of the secondary sleeve and the second-secondary coupling member is threaded along the other approximately half of the secondary sleeve.
14. The catheter assembly of any one of claims 1 to 12, further comprising a secondary coupling member and a plurality of secondary openings, wherein the secondary coupling member cooperates with the plurality of secondary openings for releasably coupling portions of the sheet to one another to constrain the expandable device in an intermediate configuration, the intermediate configuration having a diameter larger than the collapsed configuration and smaller than the expanded configuration.
15. The catheter assembly of any one of claims 1 to 14, further comprising a lock wire extending through the main lumen, wherein a portion of the lock wire passes through the side port of the main lumen of the catheter, engages the steering fiber, and reenters the side port of the main lumen of the catheter thereby coupling the steering line to the catheter.

2015207853 28 Jul 2015

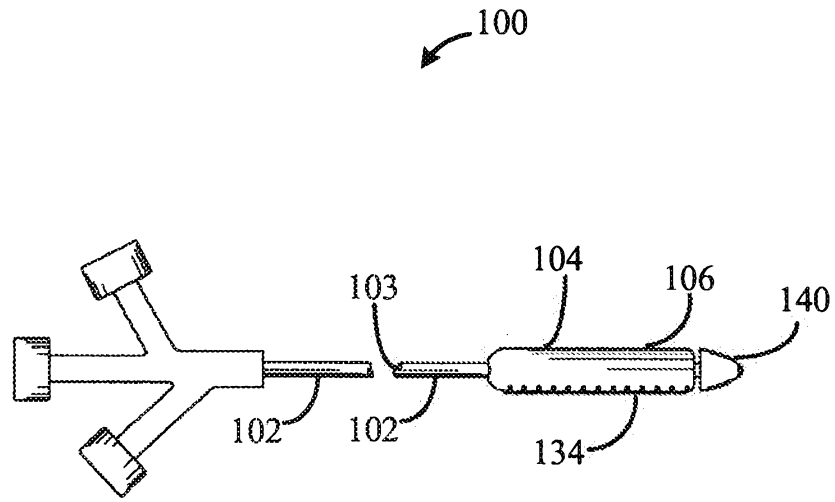

FIG. 1

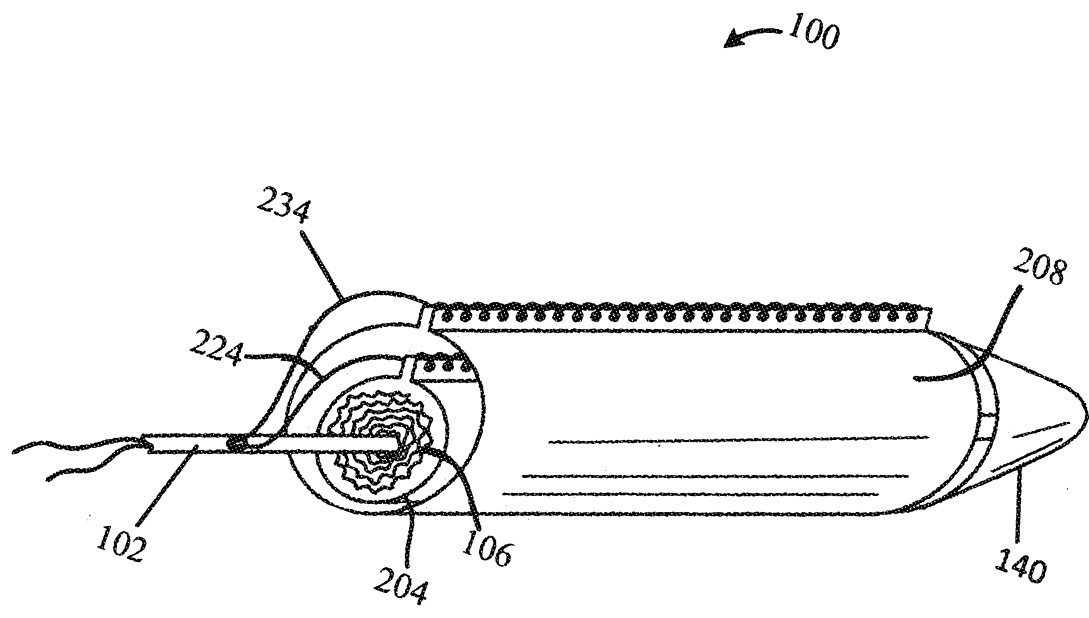

FIG. 2A

2015207853 28 Jul 2015

WO 2013/074266

3/15

PCT/US2012

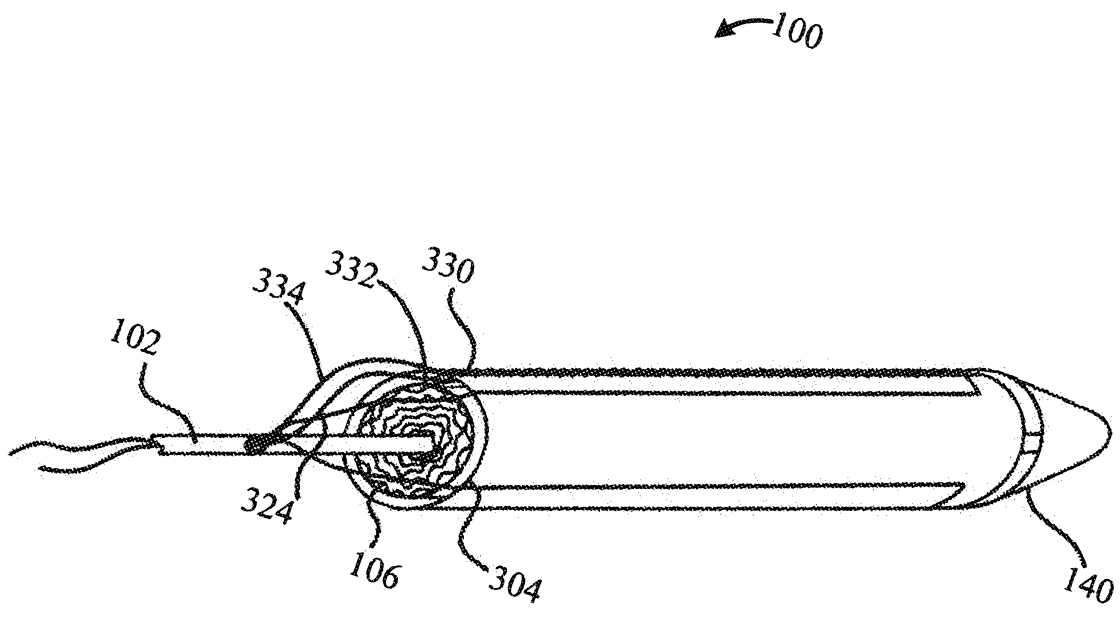

FIG. 2B

2015207853 28 Jul 2015

4/15

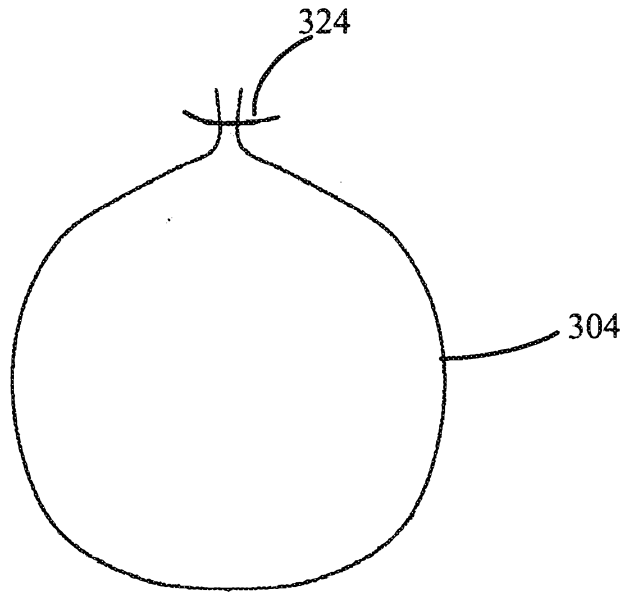

FIG. 3A

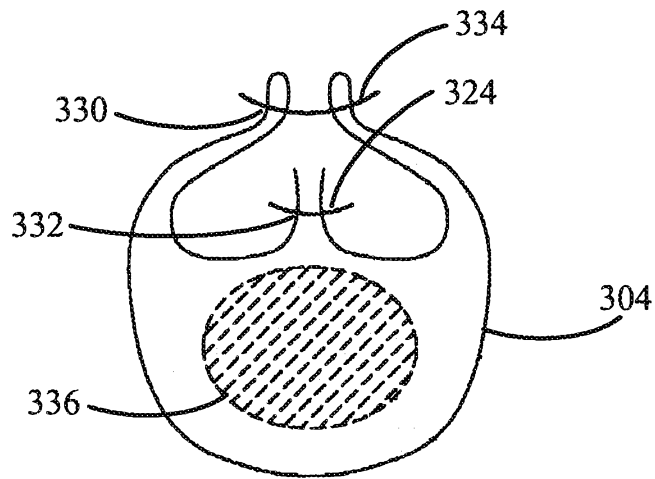

FIG. 3B

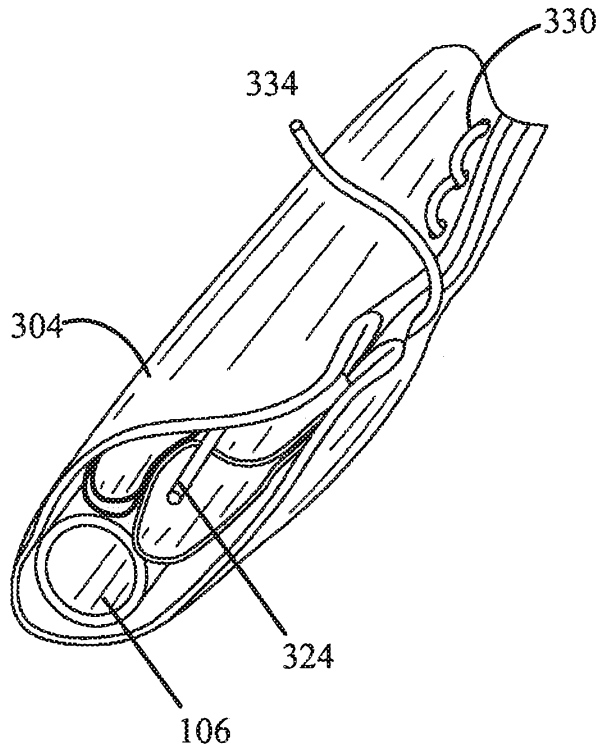

FIG. 3C

2015207853 28 Jul 2015

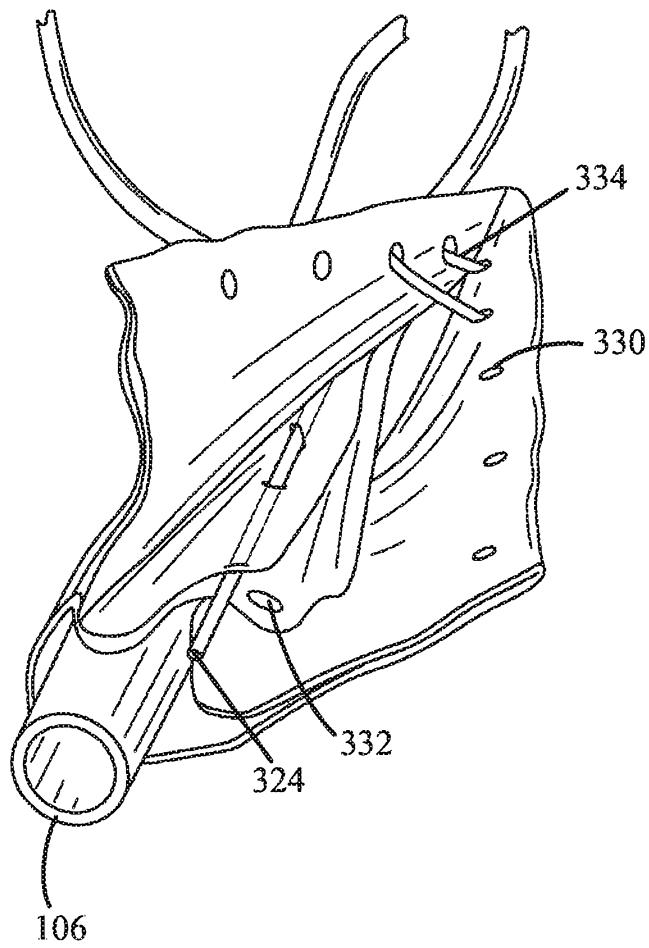

FIG. 3D

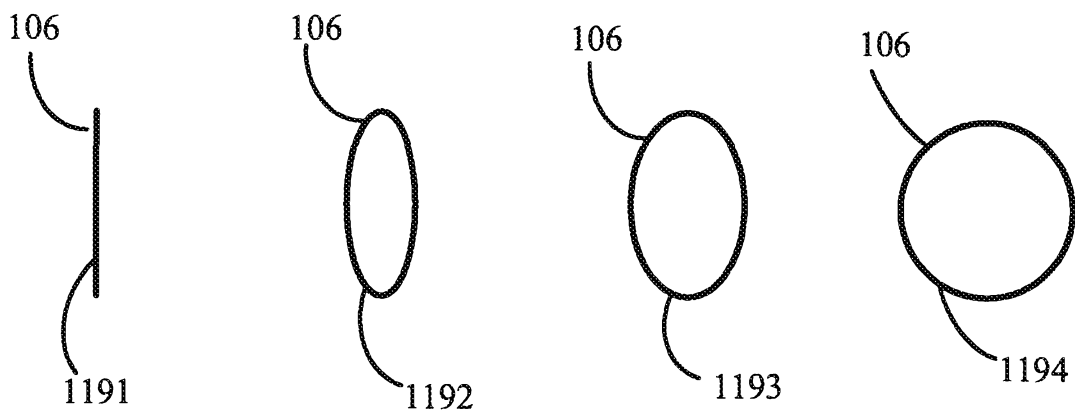

FIG. 4

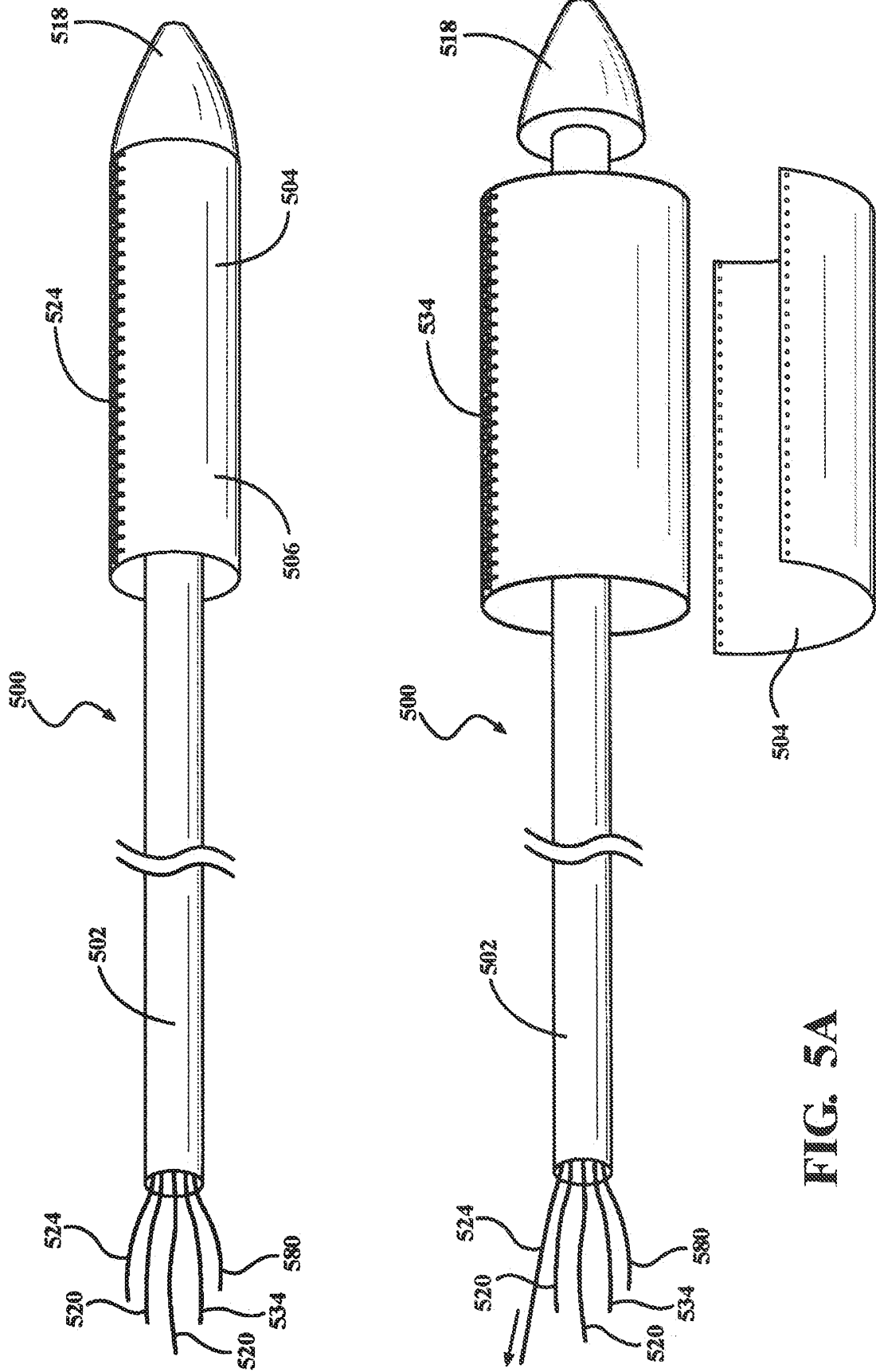

FIG. 5A

2015207853 28 Jul 2015

9/15

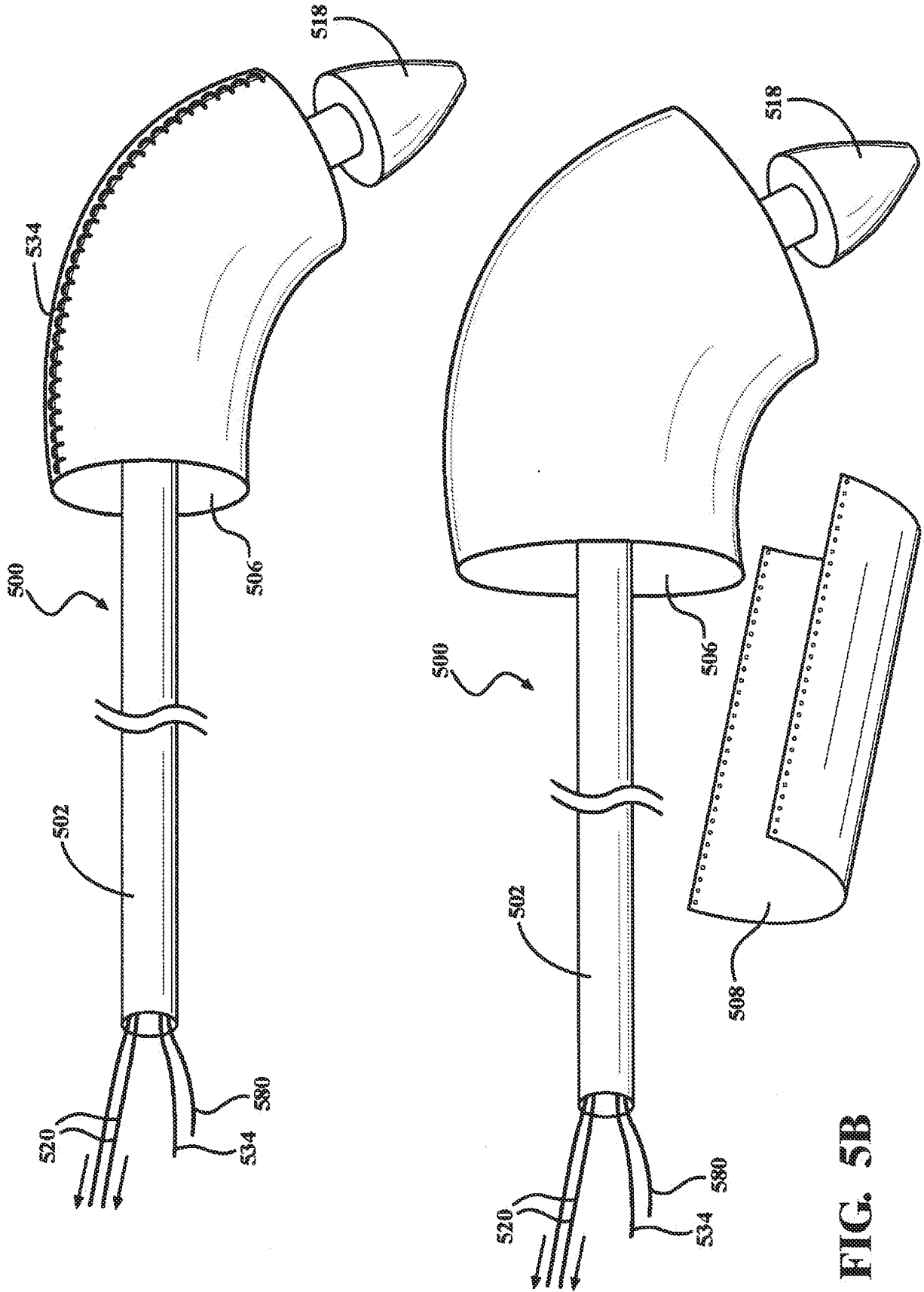

FIG. 5B

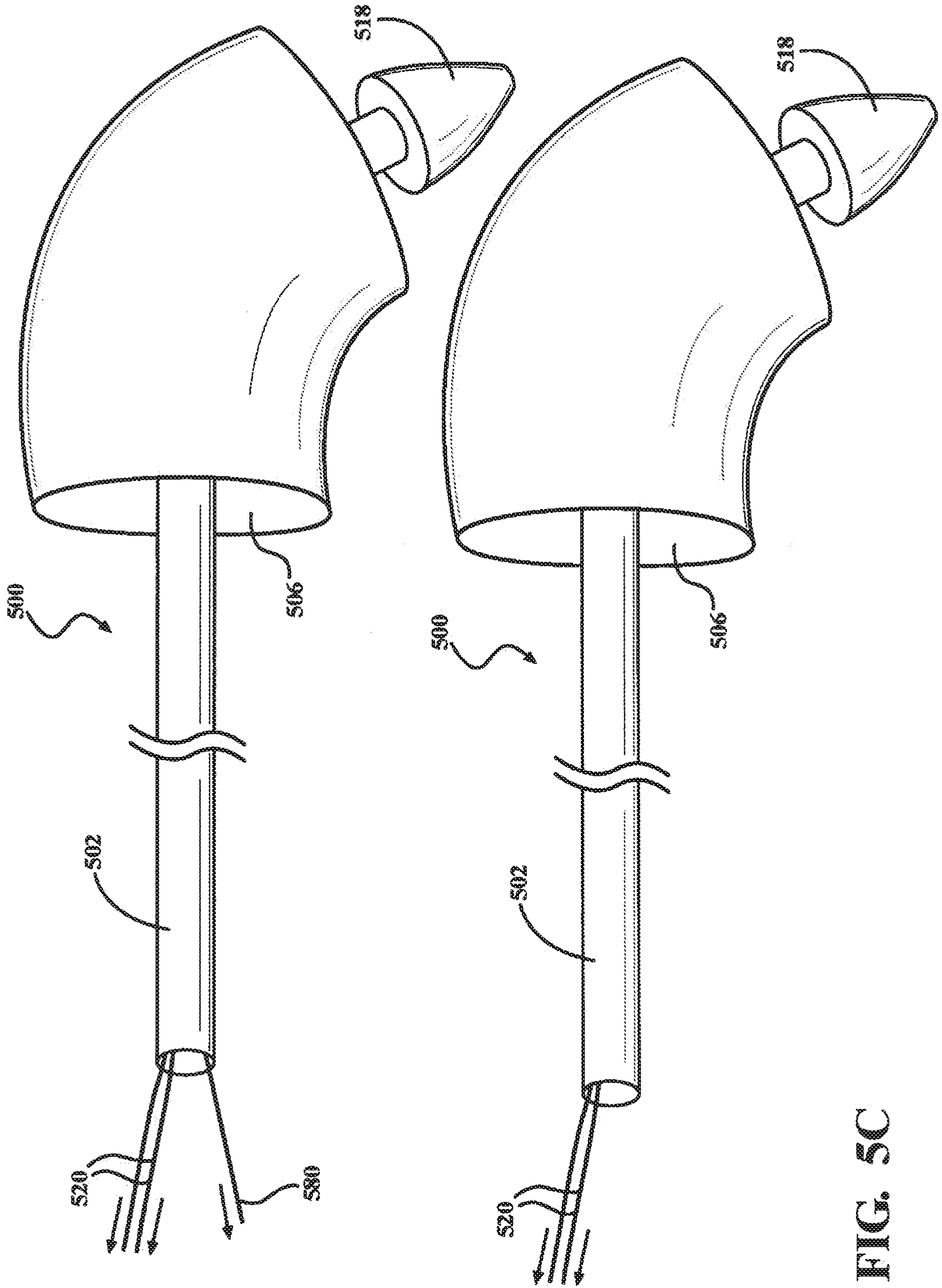

FIG. 5C

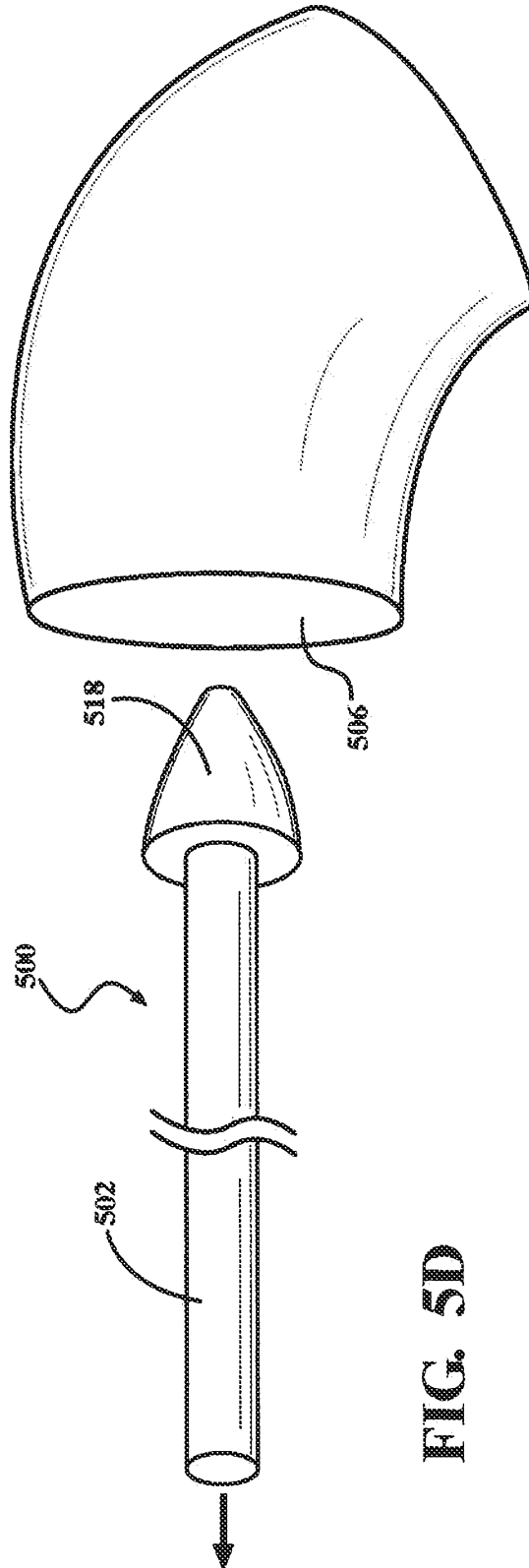

FIG. 5D

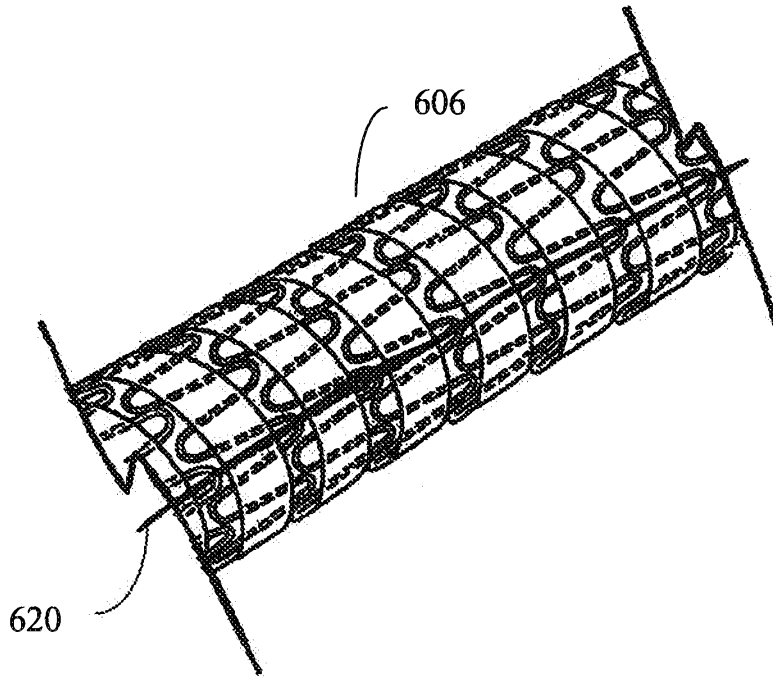

FIG. 6

FIG. 7A

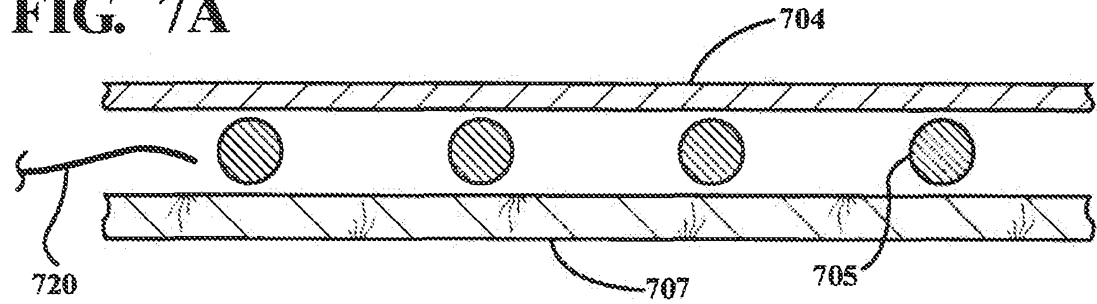

FIG. 7B

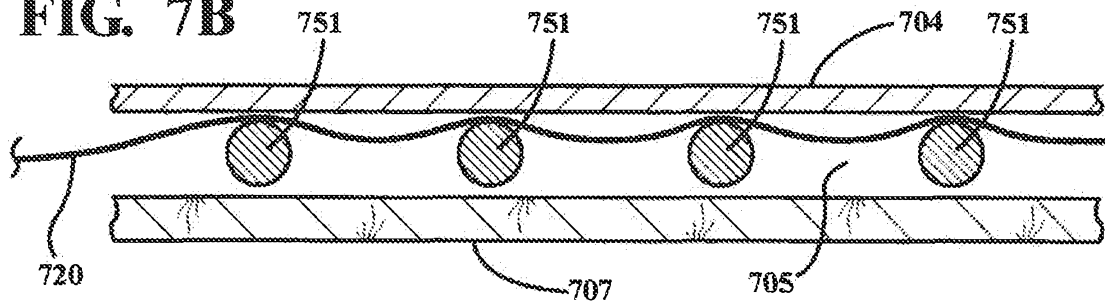

FIG. 7C

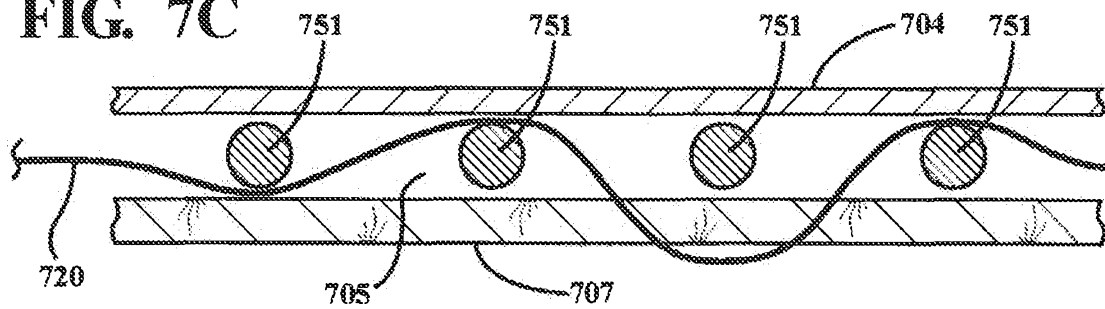

FIG. 7D

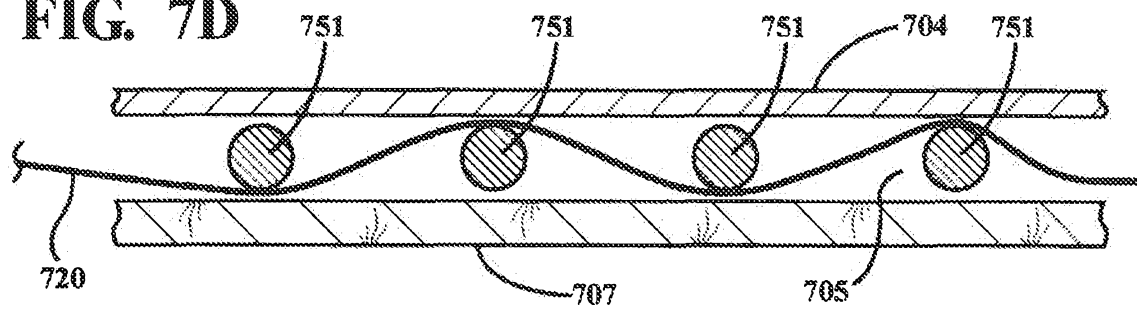

FIG. 7E

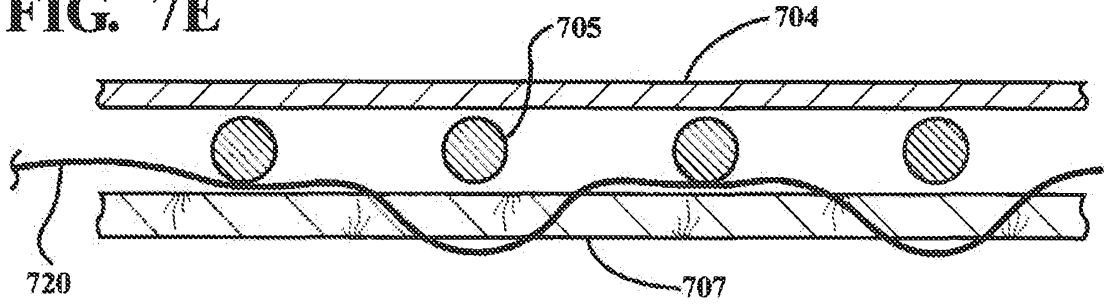

FIG. 7F

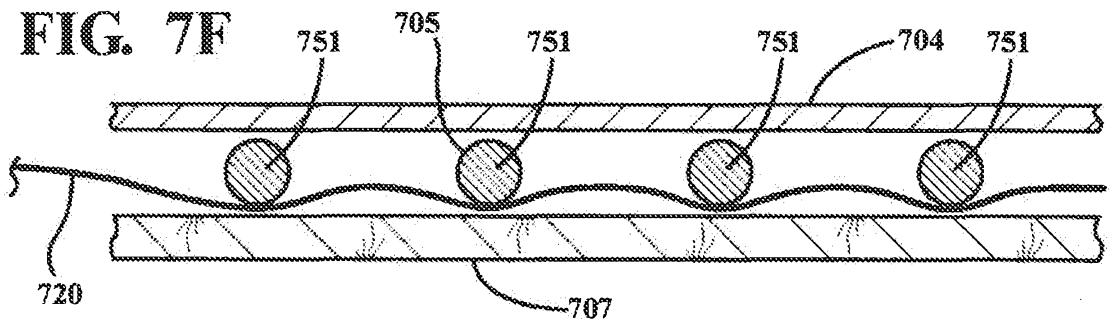

FIG. 7G

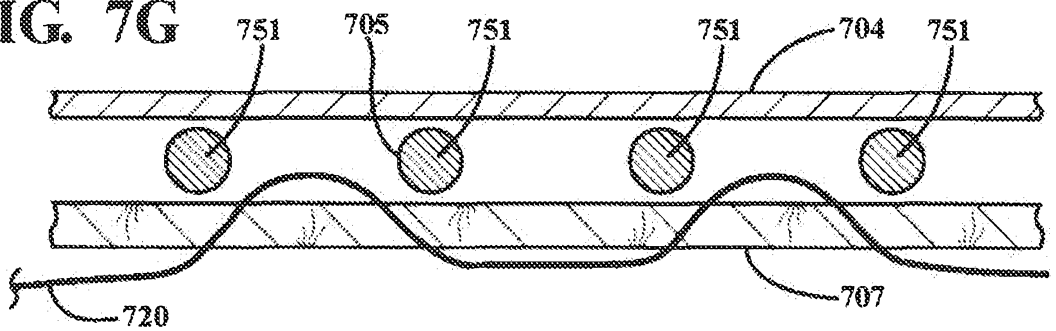
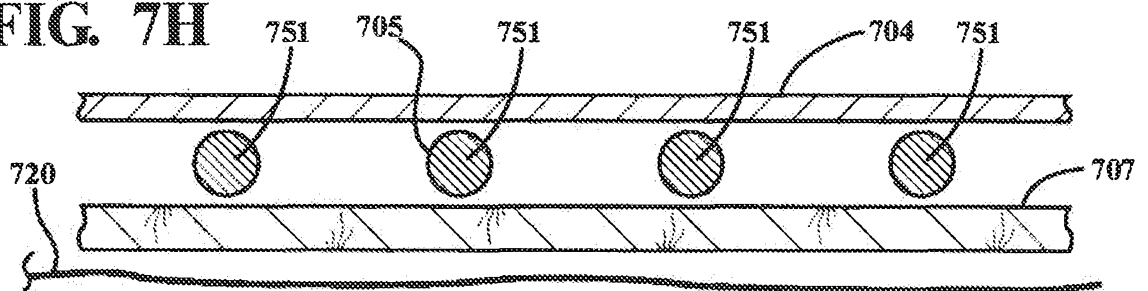

FIG. 7H



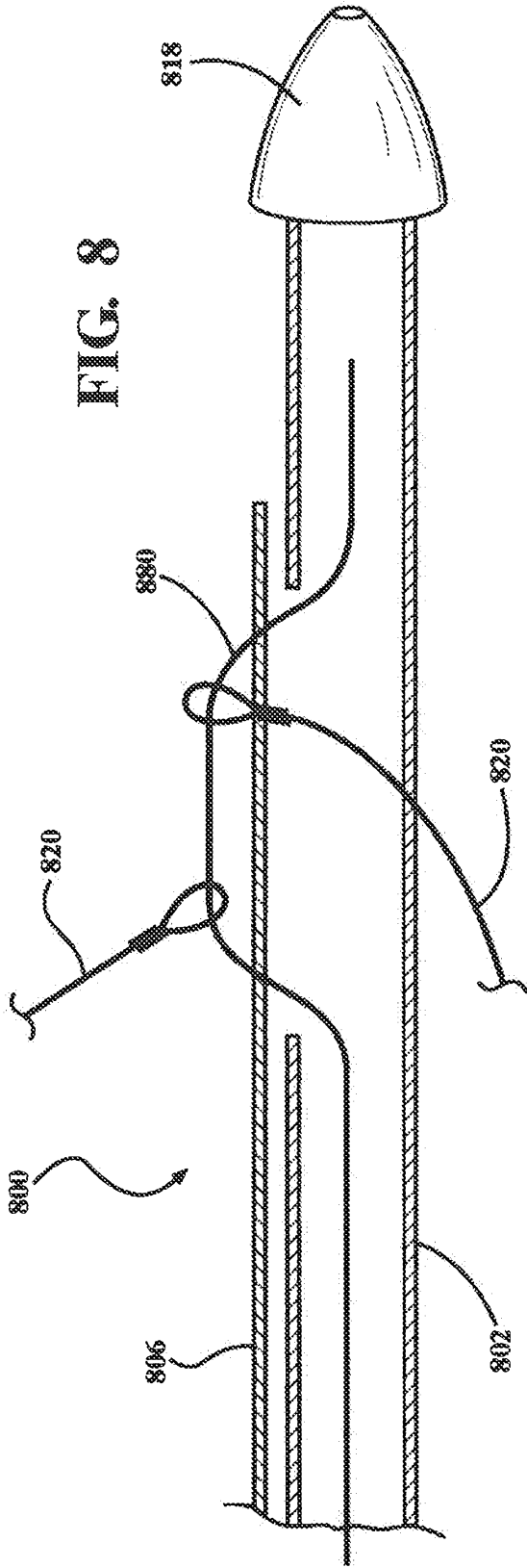

FIG. 8

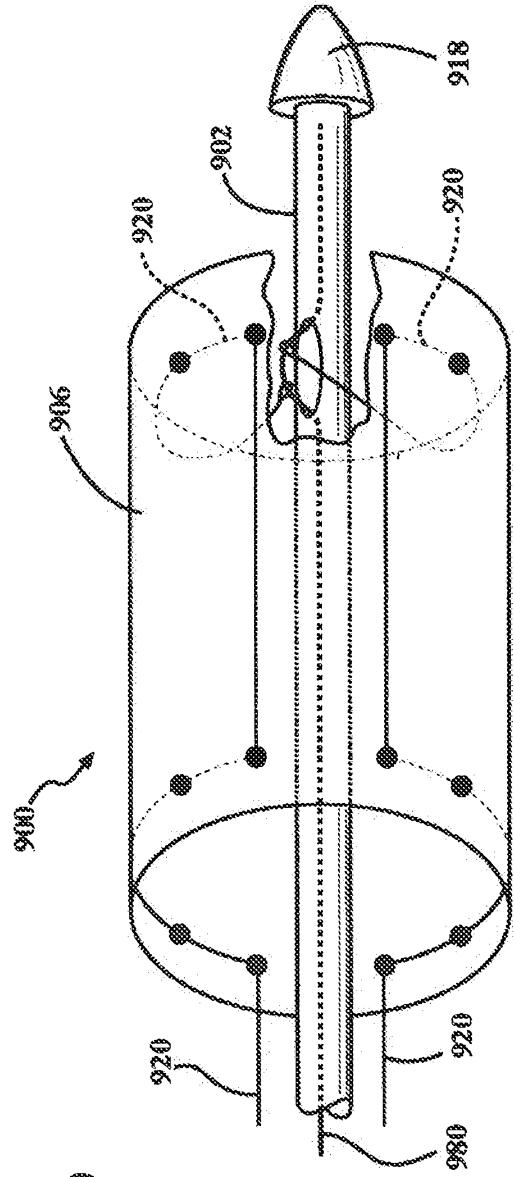

FIG. 9