

(19)
(12)

(KR)
(A)

(51) 。 Int. Cl. 7
A61B 17/68

(11)
(43)

2003 - 0002306
2003 01 08

(21) 10 - 2002 - 0033600
(22) 2002 06 17

(30) 09/894,315 2001 06 28 (US)

(71) 02767 - 0350 325

(72) 89106 가 101 600

(74)

:

(54)

가 .

가 . ,

1

2 1

3a

3b

4a

4b 4a

5a

5b 5a

6

7a

7b 7a

7c 7a

8a

8b 8a

9a

9b

10 9a

* *

10: 20:

22: 24:

26: 28:

30: 32: 1

34: 2 40:

43: 50:

51: 52: 1

54: 2 56:

62: 1 64: 2

(fusion cage)

(wear and tear),

가

()

가

가

가

(distraction)

가

가

가

가

가

가

(interbody)

1 2 . 1 2 가 1 2 ,

1 2 .

, , 가 , 가

1 2 , (10) , (20) (40) . (10)

(20) (22, 24), (26, 28), 1 2 (32, 34) (43) (40) (42, 44), (46, 48), (52, 54) (43) , C (50) (50) (51)

(50) (40) (51) (20) (20) , (40)가 (20)

3a (22, 24), (26, 28), 1 2 (32, 34) (20) 가 (20) , (40) 가 (10) (40)가 (40) (20) (20) (22, 24) 3a , 가 (20) 가

3b (22, 24) (21) (21) (21) (26) (converging surface) (17) , (17) (17) (21) 7.5° 10 50% , 10 25° , 1 가 가

(20) (20) (22, 24)
 (43) (22, 24) (22, 24)
 3a (22, 24) (30)
 (22, 24) 가

(30) 가 (22, 24)
 (20) (32, 34) (30)
 (p) (36) (38) (30)
 (36) (20) (20) (26)
 () () 5° 60° (22, 24) (39)

(30)
 0.75mm (h) (22, 24) 0.5 2.5mm (expu
 lsion) 가

(20) 가 (40) 4a 4b (40)
 (42, 44) (46, 48), (46, 48)
 1 2 (52, 54) C (40)
 (40) (42, 44) (51) (40)
 (46) (50) (50)
 (51) (20) (50) 1 2 (52, 54)
 (56) (20) (40) (46) (52, 54)
 (32, 34) (20)
 (20)

4b (40) (48) (47)
 가 (45) (45) (mallet)
 가 (40) 가 (20) 가
 (20) (40)

(40) (52, 54) (48) C (40)
 (52, 54) 가 (52, 54) (40) (51)
 (52, 54) 가 (58)
 (58) 가 (52, 54)

(40) (42, 44) (40)
 (46) (56) (56)
 가 , (42, 44)
 (56) (40) 10 50% ,
 (x) 10 25 ° , 17.5 ° 가 , (56)
 가

5a 5b (46, 48)
 (62, 64) 1 2 (62, 64) (51) 1
 2 (ingrowth) (66, 68) (66, 68) 가
 (63, 64) (60) 가

가 (20) (30') (30)
 (42, 44) (48) 4a , (40)
 (42, 44) (56) 가 (40)

6 7c

6 5a 5b (60) (70) (60)가 (20)
 (80) (70) (72, 74) (72, 74) (76) (78)
 (70) , (72, 74) , 0 ° 15 ° , 10 ° , (70)
 (72, 74) 가 (70) 가 ,
 (20) () , 가

7a 7c (96, 98) (92)
 (94) (90) 가 ,
 (92) (94) (96, 98)
 (92, 94) (102) (104)
 7b (96, 98) (R₂) (104) (R₁) , 7c
 (96, 98) (R₁, R₂)
 50mm 350mm , 100mm 200mm 가 ,
 (R₁, R₂) 150mm

(20), (32, 34)
 (20) (22, 24)
 90°
 (32, 34) (20)
 (20)가 가 가
 가
 (20)
 (20)
 8a 8b 7a 7c
 (94) (94) (92) (108) (가)
 90) (108) 가 (94) (가)
 28) 가 (112) 가 (108), (가)
 (94) (94) 가 (94) (가)
 108) (94) 가 (94) (94) (가)
 (92) (108) (94) (92)
 (94)가 (108) (94) (92)
 6) (92) 8b (92) (108) (92) (9)
 (94) (91) (94) (92)
 (16) (108) 가 가
) (2) (20) (40) (20)
 (12), (40) (52, 54) (가)
 (14) 가 (12) (14)
 (40) (40) (20) (20) (가)
 (12, 14) (48)
 가 (가) 0° 5° (40)
 (20) 가

()가 (108) (92) (94) (96)(8b)

9a 10 , ((120) (122, 124) , 가 (120) (126, 128) 1 (122) 1 (132) (130) (128) , 2 (124) 2 (134) (126) , , 1 2 (132, 134) 가 1 2 (132, 134) (150) (126) 0) 1 2 (132, 134)가 (150) , (pawl)(161)가 (128) (126) (165) (163)가 (180) , (vise - grip)(182) (150) 9b (180) (126, 128) 가 1 2 (132, 134) (80) (toggle mechanism)() (182) (132, 134) ()

10 , (122, 124) (136) (80) (138) (138) (122, 124) (136) (80) (72, 74) (78) (140) 가 가 (80) (120) (80)(6)가 , 가 (120)

(138) (80) (80) (140) , (126, 128) (120) (138) (80) (150) (126, 128) (80) (120) (80) (80) (150) (80) (94) (92) , (92)가

가

가

(57)

1.

가,

가

가 ,

2.

1

3.

2

1

2

4.

3

1

2

5.

4

1

2

6.

4

7.

6

8.

7

9.

5 , 가

10.

9 , 가

11.

9 , 가

12.

9 , 가

13.

5 ,

14.

13 ,

15.

1 , 가 ,

16.

1 , 가 ,

17.

16 ,

18.

1 ,

19.

1 , 가

28.

27 , 가 ,

29.

23 ,

30.

23 , 가 ,

31.

23 , 가 ,

32.

31 ,

33.

23 ,

34.

23 , 가

35.

34 , 가 ,

36.

23 , , , , ,

37.

, , 1 2 ,
, , 1 2 ,

38.

,
 ,
 ,
 , 1 2 ,
 , 1 2 ,
 ,
 ,
 ,
 가 ,
 가 1 2 ,
 1 2 1 2 1 2 ,

39.

, 가 1 2 ,
 ,
 1 2 ,

40.

39

41.

, 가 ,

가

42.

41

43.

가

가

1

2

1

2

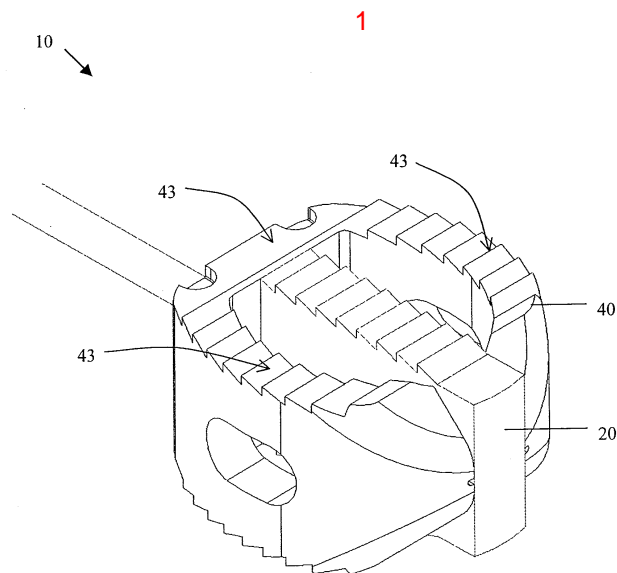

2

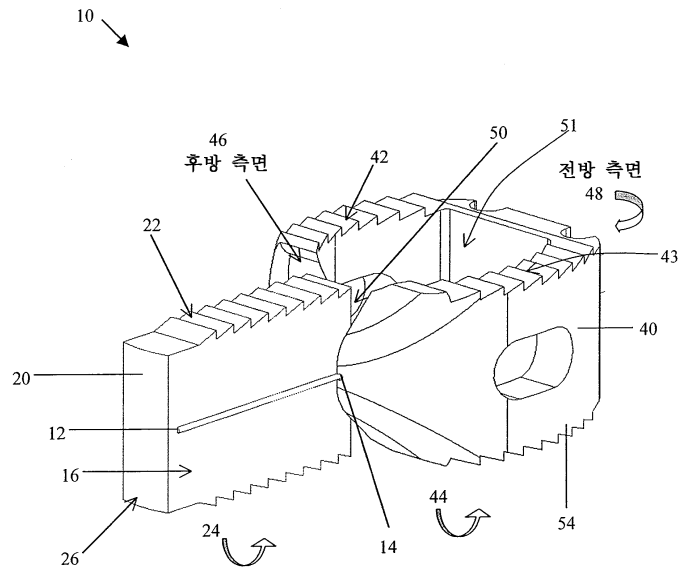

3a

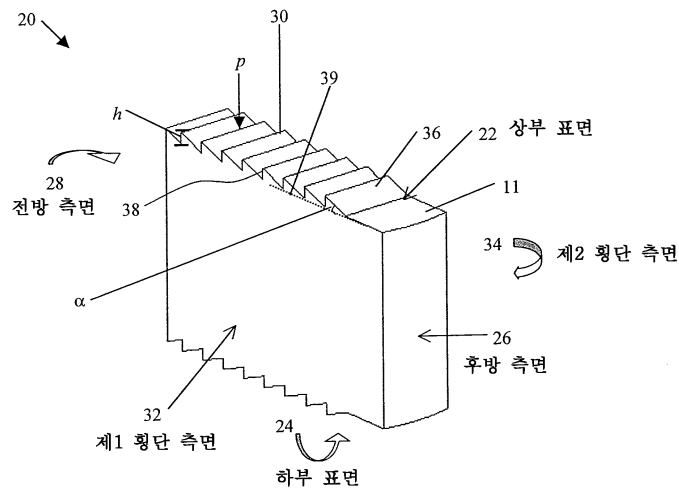

3b

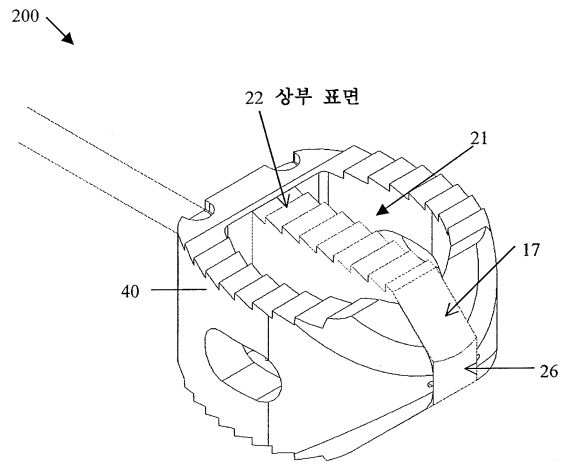

4a

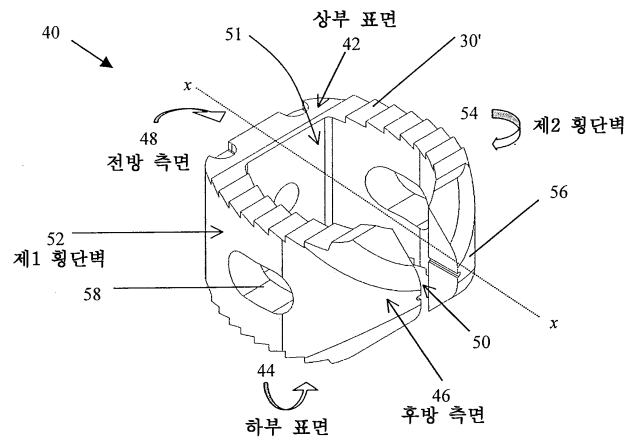

4b

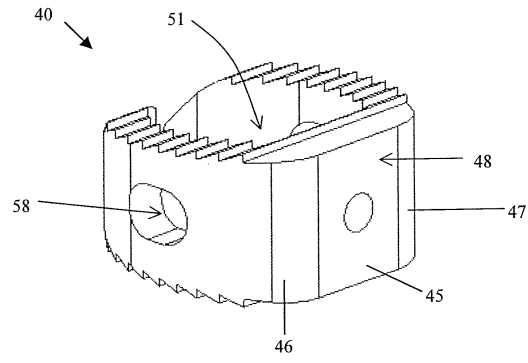

5a

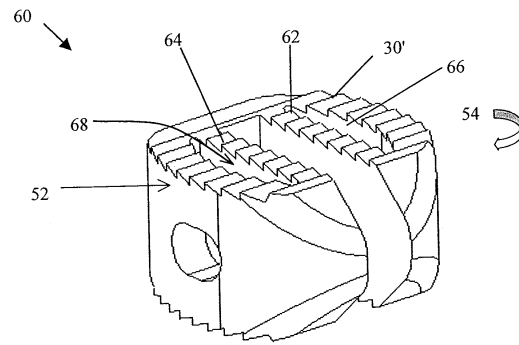

5b

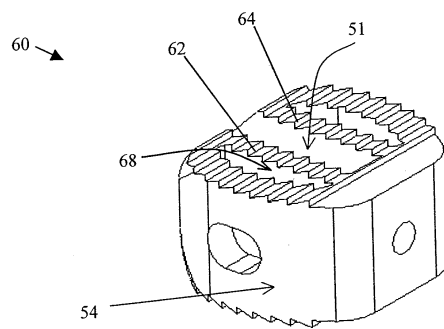

6

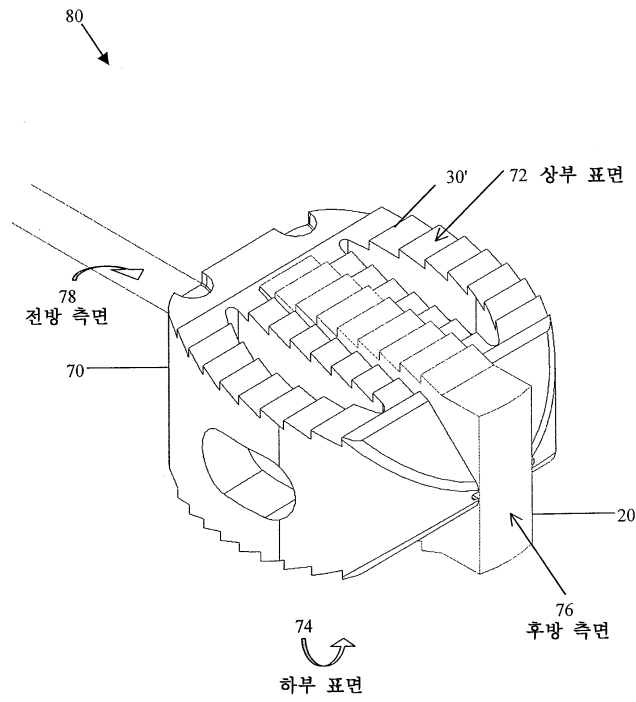

7a

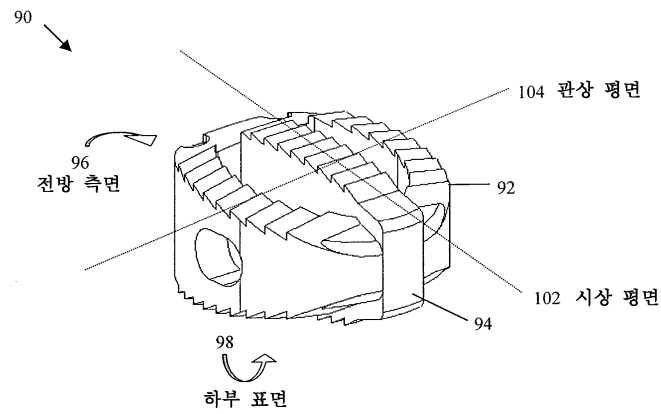

7b

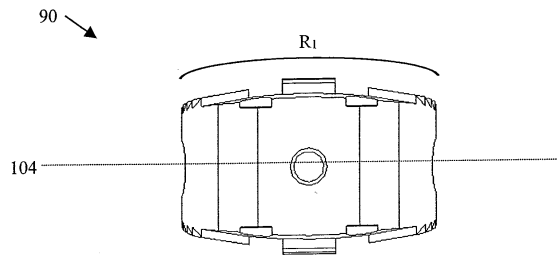

7c

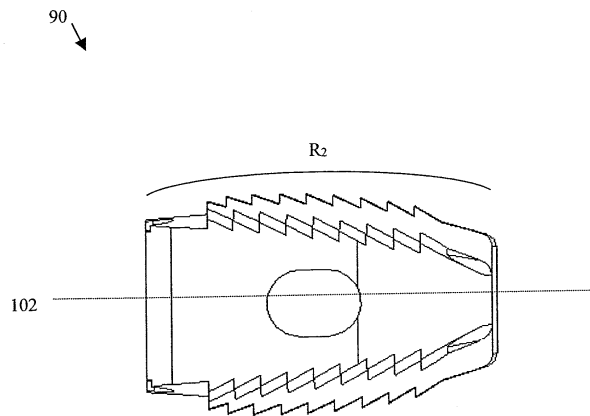

8a

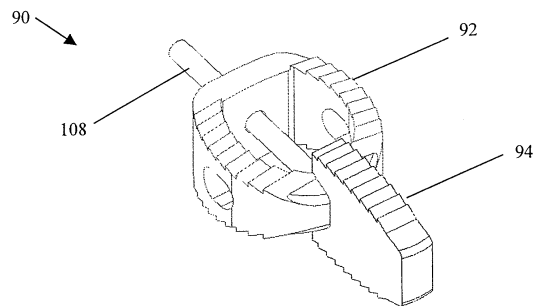

8b

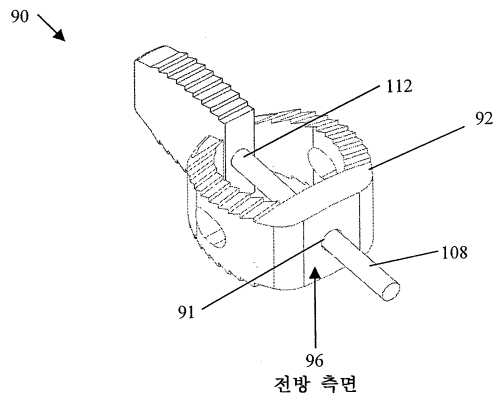

9a

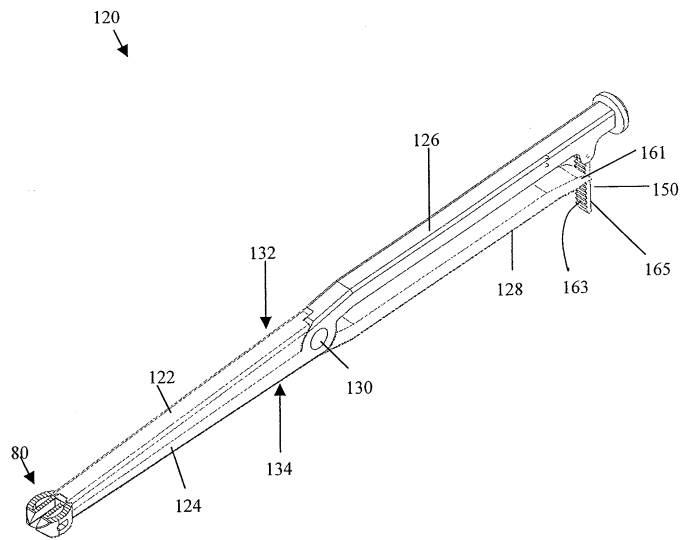

9b

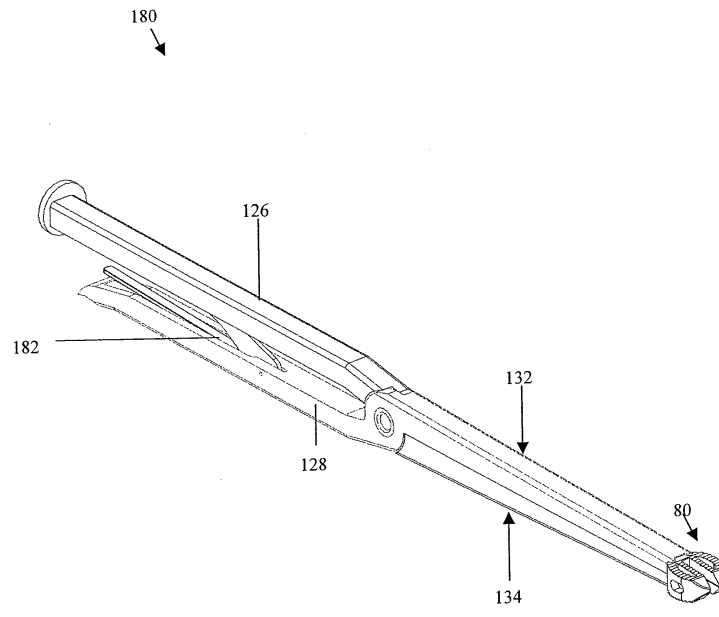

10

