

(19) AUSTRALIAN PATENT OFFICE

(54) Title
System and methods for performing percutaneous pedicle integrity assessments

(51)⁶ International Patent Classification(s)
A61B 17/56 (2006.01) 20060101ALI2005100
A61B 5/0488 8BMEP **A61B**
(2006.01) 17/88
A61B 5/11 (2006.01) 20060101ALI2007072
A61B 17/88 (2006.01) 1BMEP **A61N**
A61N 1/05 (2006.01) 1/05
A61N 1/08 (2006.01) 20060101ALI2006072
A61B 5/05 (2006.01) 2BMEP **A61N**
A61B 17/56 1/08
20060101AFI2005122 20060101ALI2006072
0BMJP **A61B** 2BMEP **A61B**
5/0488 5/05
20060101ALI2005100 20060101ALN200510
8BMEP **A61B** 08BMEP
5/11 PCT/US02/35047

(21) Application No: 2002353954 (22) Application Date: 2002 .10 .30

(87) WIPO No: W003/037170

(30) Priority Data

| (31) Number | (32) Date | (33) Country |
|-------------|--------------|--------------|
| 60/336,501 | 2001 .10 .30 | US |

(43) Publication Date : 2003 .05 .12

(43) Publication Journal Date : 2003 .07 .10

(71) Applicant(s)
Nuvasive, Inc.

(72) Inventor(s)
Kaula, Norbert; Elbanna, Jamil; Miles, Patrick; Martinelli, Scot; Blewett,
Jeffrey; Gharib, James; Finley, Eric; Farquhar, Allen

(74) Agent/Attorney
Phillips Ormonde & Fitzpatrick, Level 21 367 Collins Street, Melbourne, VIC, 3000

(56) Related Art
EP 0972538
US 5196015
US 5474558

(12) INTERNATIONAL APPLICATION PUBLISHED UNDER THE PATENT COOPERATION TREATY (PCT)

(19) World Intellectual Property Organization
International Bureau



(43) International Publication Date
8 May 2003 (08.05.2003)

PCT

(10) International Publication Number
WO 03/037170 A3

- (51) International Patent Classification: **A61B 5/04**
(21) International Application Number: PCT/US02/35047
(22) International Filing Date: 30 October 2002 (30.10.2002)
(25) Filing Language: English
(26) Publication Language: English
(30) Priority Data: 60/336,501 30 October 2001 (30.10.2001) US
(71) Applicant (for all designated States except US): **NUVA-SIVE, INC.** [US/US]; 10065 Old Grove Road, San Diego, CA 92131 (US).
(72) Inventor: **BLEWETT, Jeffrey** (deceased).
(72) Inventors; and
(75) Inventors/Applicants (for US only): **MILES, Patrick** [US/US]; 5227 Greenwillow Lane, San Diego, CA 92130 (US). **MARTINELLI, Scot** [US/US]; 9624 Pasco Montrail, San Diego, CA 92129 (US). **FINLEY, Eric** [US/US]; 10548 Caminito Canyon, San Diego, CA 92131 (US). **ELBANNA, Jamil** [US/US]; 17285 Grandee Place, San Diego, CA 92128 (US). **GHARIB, James** [US/US]; 10918 Derrydown Way, San Diego, CA 92130 (US). **FARQUHAR, Allen** [US/US]; 6220 Hannon Court, San Diego, CA 92117 (US). **KAULA, Norbert** [US/US]; 8258 West 72nd Avenue, Arvada, CO 80005 (US).
(74) Agent: **SPANGLER, Jonathan**, NuVasive, Inc., 10065 Old Grove Road, San Diego, CA 92131 (US).
(81) Designated States (national): AE, AG, AL, AM, AT, AU, AZ, BA, BB, BG, BR, BY, BZ, CA, CH, CN, CO, CR, CU, CZ, DE, DK, DM, DZ, EC, EE, ES, FI, GB, GD, GE, GM, GR, HU, ID, IL, IN, IS, JP, KE, KG, KP, KR, KZ, LC, LK, LR, LS, LT, LU, LV, MA, MD, MG, MK, MN, MW, MX, MZ, NO, NZ, OM, PH, PL, PT, RO, RU, SD, SE, SG, SI, SK, SL, TJ, TM, TN, TR, TT, TZ, UA, UG, US, UZ, VC, VN, YU, ZA, ZM, ZW.
(84) Designated States (regional): ARIPO patent (GH, GM, KE, LS, MW, MZ, SD, SL, SZ, TZ, UG, ZM, ZW).

[Continued on next page]

(54) Title: SYSTEM AND METHODS FOR PERFORMING PERCUTANEOUS PEDICLE INTEGRITY ASSESSMENTS

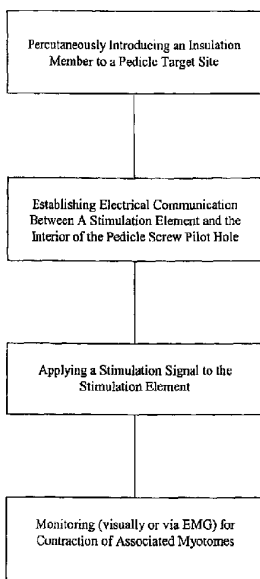

(57) Abstract: The present invention involves systems (20) and related methods for performing percutaneous pedicle integrity assessments involving the use of neurophysiology. The fundamental method steps for performing the percutaneous pedicle integrity assessments include (a) percutaneously introducing an insulation member to a pedicle target site; (b) establishing electrical communication between a stimulation element and an interior of a pedicle screw pilot hole; (c) applying a stimulation signal to the stimulation element; and (d) monitoring to assess whether nerves adjacent the pedicle are innervating as a result of the step of applying the stimulation signal to the stimulation element.

WO 03/037170 A3



Eurasian patent (AM, AZ, BY, KG, KZ, MD, RU, TJ, TM),
European patent (AT, BE, BG, CH, CY, CZ, DE, DK, EE,
ES, FI, FR, GB, GR, HU, IT, LU, MC, NL, PT, SE, SK,
TR), OAPI patent (BF, BI, CF, CG, CI, CM, GA, GN, GQ,
GW, ML, MR, NI, SN, TD, TG).

For two-letter codes and other abbreviations, refer to the "Guidance Notes on Codes and Abbreviations" appearing at the beginning of each regular issue of the PCT Gazette.

Published:

— with international search report

(88) Date of publication of the international search report:

13 November 2003

SYSTEM AND METHODS FOR PERFORMING PERCUTANEOUS PEDICLE INTEGRITY ASSESSMENTS

5 **CROSS-REFERENCES TO RELATED APPLICATIONS**

 This is an International Patent Application claiming the benefit of priority under
35 USC 119(e) of commonly owned and co-pending U.S. Provisional Patent Application
60/336,501 entitled "Spinal Surgery Systems and Methods," filed October 30, 2001, the
entire contents of which are hereby expressly incorporated by reference into this
10 disclosure as if set forth fully herein.

BACKGROUND OF THE INVENTION

I. Field of the Invention

 The present invention relates to a system and methods generally aimed at surgery.
15 More particularly, the present invention is directed at a system and related methods for
performing percutaneous pedicle integrity assessments involving the use of
neurophysiology.

II. Description of Related Art

20 A trend in spinal surgery is toward performing surgery in a minimally invasive
or minimal access fashion to avoid the trauma of so-called open or "direct access"
procedures. A specific area of interest is in the percutaneous placement of pedicle
screws, which are typically employed to effect posterior fixation in spinal fusion
procedures. While great strides are being made in this area, a risk exists (as it does in
25 open procedures) that the pedicle may become breached, cracked, or otherwise
compromised due to the formation and/or preparation of the pilot hole (designed to
receive a pedicle screw) and/or due to the introduction of the pedicle screw into the pilot
hole. If the pedicle (or more specifically, the cortex of the medial wall, lateral wall,
superior wall and/or inferior wall) is breached, cracked, or otherwise compromised, the
30 patient may experience pain or neurologic deficit due to unwanted contact between the
pedicle screw and exiting nerve roots. This oftentimes necessitates revision surgery,
which is disadvantageously painful for the patient and costly, both in terms of recovery
time and hospitalization.

Various attempts have been undertaken at performing pedicle integrity assessments. As used herein, the term "pedicle integrity assessment" is defined as detecting or otherwise determining whether a part of a pedicle has been breached, cracked, or otherwise compromised due to the formation and/or preparation of the pilot hole (designed to receive a pedicle screw) and/or due to the introduction of the pedicle screw into the pilot hole. "Formation" is defined as the act of creating an initial pilot hole in a pedicle, such as through the use of a drill or other hole-forming element. "Preparation" is defined as the act of refining or otherwise acting upon the interior of the pilot hole to further prepare it to receive a pedicle screw, such as by introducing a tap or reamer element into the initial pilot hole. "Introduction" is defined as the act of inserting or otherwise placing a pedicle screw into the initially formed and/or prepared pilot hole, such as by screwing the pedicle screw into the pilot hole via a screw driver or similar element.

Among the attempts, X-ray and other imaging systems have been employed, but these are typically quite expensive and are oftentimes limited in terms of resolution such that pedicle breaches may fail to be detected.

Still other attempts involve capitalizing on the insulating characteristics of bone (specifically, that of the medial wall of the pedicle) and the conductivity of the exiting nerve roots themselves. That is, if the medial wall of the pedicle is breached, a stimulation signal applied to the pedicle screw and/or the pilot hole (prior to screw introduction) will cause the various muscle groups coupled to the exiting nerve roots to contract. If the pedicle wall has not been breached, the insulating nature of the pedicle will prevent the stimulation signal from innervating the given nerve roots such that the associated muscle groups will not twitch. Traditional EMG monitoring systems may be employed to augment the ability to detect such innervation. A drawback with such prior art systems is that they do not lend themselves to assessing pedicle integrity in cases where pedicle screws are placed in a percutaneous fashion, such as may be accomplished by any number of commercially available percutaneous pedicle screw implantation systems. With the anticipated increase in the number of such percutaneous pedicle screw procedures, a significant number of patients will be at risk of having misplaced pedicle

screws given the lack of a percutaneous manner of performing pedicle integrity assessments.

5 It would be desirable to address this need and eliminate, or at least reducing, the effects of the shortcomings of the prior art as described above.

SUMMARY OF THE INVENTION

10 The present invention provides, according to a first broad aspect, a system for performing percutaneous pedicle integrity assessments during spine surgery comprising the steps of: (a) percutaneously introducing one of an insulated K-wire and an insulated shaft of a pedicle screw pilot hole preparation tool to a pedicle target site; (b) establishing electrical communication between a stimulation element and an interior of a pedicle screw pilot hole; (c) applying a stimulation signal to said stimulation element; and (d) monitoring to assess whether nerves adjacent said pedicle
15 are innervating as a result of the step of applying said stimulation signal to said stimulation element.

20 The present invention provides, according to a second broad aspect of the present invention, a method for performing percutaneous pedicle integrity assessments during spine surgery comprising the steps of: (a) percutaneously introducing an insulated K-wire into contact with at least one of a pedicle screw and a pedicle screw pilot hole; (b) applying a stimulation signal to said K-wire; and (c) monitoring to assess whether nerves adjacent said pedicle are innervating as a result of the step of applying said stimulation signal to said K-wire.

25 The present invention provides, according to a third broad aspect of the present invention, a method for performing percutaneous pedicle integrity assessments during spine surgery comprising the steps of: (a) percutaneously introducing an insulated pedicle screw pilot hole preparation tool to the approximate opening of a pedicle screw
30 pilot hole; (b) applying a stimulation signal to said pedicle screw pilot hole preparation tool; and (c) monitoring to assess whether nerves adjacent said pedicle are innervating as a result of the step of applying said stimulation signal to said pedicle screw pilot hole preparation tool.

5 The present invention provides, according to a fourth broad aspect of the present invention, a method for performing percutaneous pedicle integrity assessments during spine surgery comprising the steps of: (a) percutaneously introducing an insulated K-wire into contact with a pedicle screw pilot hole; (b) applying a stimulation signal to said K-wire; (c) monitoring to assess whether nerves adjacent said pedicle are innervating as a result of the step of applying said stimulation signal to said K-wire; (d) percutaneously introducing an insulated member to the approximate opening of a pedicle screw pilot hole; (e) introducing a tap member through said insulated member to prepare said pedicle screw pilot hole; (f) applying a stimulation signal to said tap member; and (g) monitoring to assess whether nerves adjacent said pedicle are innervating as a result of the step of applying said stimulation signal to said tap member.

15 The present invention provides, according to a fifth broad aspect of the present invention, a system for performing percutaneous pedicle integrity assessments during spine surgery. The system comprises an insulated K-wire configured for percutaneous introduction to a pedicle target site within a patient and having an uninsulated stimulation region at a distal end configured for contacting at least one of a pilot hole formed in said pedicle and a screw implanted in said pedicle. The stimulation source is in electrical communication with said stimulation region for selectively applying a stimulation signal to said stimulation region to assess whether nerves adjacent said pedicle target site innervate as a result of applying said stimulation signal to said stimulation region.

25 The present invention provides, according to a sixth broad aspect of the present invention, a system for performing percutaneous pedicle integrity assessments during spine surgery. The system comprises a pedicle preparation tool with a shaft insulated along at least a portion positionable within a patient and configured for percutaneous introduction to a pedicle target site within said patient, said pedicle preparation tool having an uninsulated stimulation region at a distal end. A stimulation source in

electrical communication with said stimulation region selectively applies a stimulation signal to said stimulation region to assess whether nerves adjacent said pedicle target site innervate as a result of applying said stimulation signal to said stimulation region.

5

But for the systems and methods of the present invention, patients may be released and subsequently experience pain and/or neurologic deficit due to unwanted contact between the exiting nerve root and misplaced pedicle screws, which oftentimes requires another costly and painful surgery.

10

BRIEF DESCRIPTION OF THE DRAWINGS

Figure 1 is a flow chart illustrating the fundamental steps of the percutaneous pedicle integrity assessment system according to the present invention;

15

Figure 2 is a perspective view of an exemplary surgical system 20 capable of assessing pedicle integrity according to the present invention;

Figure 3 is a block diagram of the surgical system 20 shown in FIG. 2;

Figure 4 is a side view illustrating the use of first and second exemplary systems for assessing pedicle integrity according to the present invention;

5

Figure 5 is a side view illustrating the use of third and fourth exemplary systems for assessing pedicle integrity according to the present invention;

Figure 6 is a perspective view of the first exemplary system for assessing pedicle integrity according to the present invention, comprising a K-wire insulator electrically coupled to a handle assembly;

10

Figure 7 is a perspective view of the third exemplary system for assessing pedicle integrity according to the present invention, comprising a universal insulating assembly including a handle assembly coupled to an insulating cannula according to the present invention;

15

Figure 8 is a perspective view illustrating an exemplary electrical coupling mechanism capable of being disposed within the handle assembly shown in FIG. 7;

20

Figures 9-11 are perspective views illustrating insulating cannulas of varying sizes and dimensions for use with the handle assembly according to the present invention;

Figure 12 is a graph illustrating a plot of a stimulation current pulse capable of producing a neuromuscular response (EMG) of the type shown in FIG. 13;

25

Figure 13 is a graph illustrating a plot of the neuromuscular response (EMG) of a given myotome over time based on a current stimulation pulse (such as shown in FIG. 12) applied to a nerve bundle coupled to the given myotome;

30

Figure 14 is an illustrating (graphical and schematic) of a method of automatically determining the maximum frequency (F_{Max}) of the stimulation current pulses according to one embodiment of the present invention;

Figure 15 is a graph illustrating a plot of EMG response peak-to-peak voltage (V_{pp}) for each given stimulation current level (I_{stim}) forming a stimulation current pulse according to the present invention (otherwise known as a “recruitment curve”);

5 Figure 16 is a graph illustrating a traditional stimulation artifact rejection technique as may be employed in obtaining each peak-to-peak voltage (V_{pp}) EMG response according to the present invention;

10 Figure 17 is a graph illustrating the traditional stimulation artifact rejection technique of FIG. 16, wherein a large artifact rejection causes the EMG response to become compromised;

15 Figure 18 is a graph illustrating an improved stimulation artifact rejection technique according to the present invention;

 Figure 19 is a graph illustrating an improved noise artifact rejection technique according to the present invention;

20 Figure 20 is a graph illustrating a plot of a neuromuscular response (EMG) over time (in response to a stimulus current pulse) showing the manner in which voltage extrema ($V_{Max\ or\ Min}$), ($V_{Min\ or\ Max}$) occur at times T1 and T2, respectively;

25 Figure 21 is a graph illustrating a histogram as may be employed as part of a T1, T2 artifact rejection technique according to an alternate embodiment of the present invention;

 Figures 22A-22E are graphs illustrating a current threshold-hunting algorithm according to one embodiment of the present invention;

30 Figure 23 is a series of graphs illustrating a multi-channel current threshold-hunting algorithm according to one embodiment of the present invention;

Figures 24-25 are exemplary screen displays illustrating one embodiment of the pedicle integrity assessment feature of the present invention; and

Figures 26-28 are exemplary screen displays illustrating another embodiment of the pedicle integrity assessment feature of the present invention.

DESCRIPTION OF THE SPECIFIC EMBODIMENTS

Illustrative embodiments of the invention are described below. In the interest of clarity, not all features of an actual implementation are described in this specification. It will of course be appreciated that in the development of any such actual embodiment, numerous implementation-specific decisions must be made to achieve the developers' specific goals, such as compliance with system-related and business-related constraints, which will vary from one implementation to another. Moreover, it will be appreciated that such a development effort might be complex and time-consuming, but would nevertheless be a routine undertaking for those of ordinary skill in the art having the benefit of this disclosure. The systems disclosed herein boast a variety of inventive features and components that warrant patent protection, both individually and in combination.

The present invention is directed at performing percutaneous pedicle integrity assessments. FIG. 1 illustrates the fundamental method steps according to the present invention, namely: (a) percutaneously introducing an insulation member to a pedicle target site; (b) establishing electrical communication between a stimulation element and an interior of a pedicle screw pilot hole; (c) applying a stimulation signal to the stimulation element; and (d) monitoring to assess whether nerves adjacent the pedicle are innervating as a result of the step of applying the stimulation signal to the stimulation element.

The step of percutaneously introducing an insulation member to a pedicle target site may be accomplished in any of a variety of suitable fashions, including but not limited to providing the insulation member as a tubular insulation member dimensioned to receive and pass through at least one of a K-wire and a pedicle screw pilot hole preparation tool, such as a tap member. It may also be accomplished by providing a K-wire having an insulated coating with an exposed, electrically conductive distal end, as

well as a tap member having an insulated coating with an exposed, electrically conductive threaded region. The pedicle target site may, by way of example only, comprise at least one of a fully inserted pedicle screw and the opening of at least one of an initially formed pedicle screw pilot hole and a prepared pedicle screw pilot hole, depending upon the insulation member employed.

The step of establishing electrical communication between a stimulation element and an interior of a pedicle screw pilot hole may be accomplished in any of a variety of suitable fashions, including but not limited to disposing a K-wire through a K-wire insulator such that a distal tip of the K-wire contacts a fully inserted pedicle screw, which itself is in electrical communication with the interior of the pedicle screw pilot hole. It may also be accomplished by disposing a K-wire through a K-wire insulator such that the distal tip of the K-wire contacts the interior of the pedicle screw pilot hole. In yet another exemplary embodiment, it may be accomplished by bringing a stimulation element (such as a K-wire and/or electrical coupling device) into contact with a tap member disposed through the insulation member. When a K-wire constitutes the stimulation element, it may be useful to provide the tap member with a longitudinal lumen for receiving and passing the K-wire therethrough to establish electrical communication therebetween.

The step of applying a stimulation signal to the stimulation element may be accomplished in any number of suitable fashions, including but not limited to applying voltage and/or current pulses of varying magnitude and/or frequency to the stimulation element. In a preferred embodiment, the stimulation signal may be applied to the stimulation element after the initial pilot hole has been formed, after the pilot hole has been prepared (such as with a tap member) and/or after the pedicle screw has been fully inserted into the pilot hole.

The step of monitoring to assess whether nerves adjacent the pedicle are innervating as a result of the step of applying the stimulation signal to the stimulation element may be accomplished in any number of suitable fashions, including but not limited to visual inspection of the muscle groups associated with a particular nerves, as well as the use of evoked muscle action potential (EMAP) monitoring techniques (that is, measuring the EMG responses of muscle groups associated with a particular nerve).

Although shown and described within the context of a particular exemplary system having a stimulation source and monitoring capacity, it will be appreciated by those skilled in the art that any number of systems for providing a stimulation signal and for monitoring to assess pedicle breach may be employed without departing from the scope of the present invention.

In a further aspect of the present invention, information relating to the step of assessing whether nerves adjacent the pedicle are innervating as a result of the step of applying the stimulation signal to the stimulation element may be communicated to the user. This information may include, but is not necessarily limited to, visual representations of the actual stimulation threshold of an exiting nerve root alone or in combination with the stimulation threshold of a bare nerve root (with or without the difference therebetween), as well as color coded graphics to indicate general ranges of pedicle integrity (i.e. "green" for a range of stimulation thresholds above a predetermined safe value – indicating "breach unlikely", "red" for range of stimulation thresholds below a predetermined unsafe value – indicating "breach likely", and "yellow" for the range of stimulation thresholds between the predetermined safe and unsafe values – indicating "possible breach"). This is a significant feature, and advantage over the prior art, in that it provides a straightforward and easy to interpret representation as to whether a pedicle has been breached, cracked, or otherwise compromised due to the formation and/or preparation of the pilot hole and/or due to the introduction of the pedicle screw into the pilot hole.

Identifying such a potential breach is helpful in that it prevents or minimizes the chance that a misplaced pedicle screw (that is, one breaching a wall of the pedicle) will be missed until after the surgery. Instead, any such misplaced pedicle screws, when stimulated according to the present invention, will produce an EMG response at a myotome level associated with the nerve in close proximity to the pedicle screw that is breaching the pedicle wall. This will indicate to the surgeon that the pedicle screw needs to be repositioned.

FIGS. 2-3 illustrate, by way of example only, a surgical system 20 provided in accordance with a broad aspect of the present invention. The surgical system 20 includes a control unit 22, a patient module 24, an EMG harness 26 and return electrode 28

coupled to the patient module 24, and a host of pedicle screw test accessories 30 capable of being coupled to the patient module 24 via an accessory cable 32 in combination with a handle assembly 36. In the embodiment shown, the pedicle screw test accessories 30 include (by way of example only) a K-wire insulator 34, a universal insulating assembly 5 38, and a clamping-style electrical coupler 35. As will be described in greater detail below, a K-wire 37 and a tap member 39 are shown, by way of example, as exemplary stimulation elements according to the present invention. The K-wire 37 may be electrically coupled to the control unit 22 and/or patient module 24 (so as to receive a stimulation signal) through the use of the K-wire insulator 34, the universal insulating 10 assembly 38 and/or the electrical coupler 35 (provided the K-wire 37 is insulated in some manner). The tap member 39 may be electrically coupled to the control unit 22 and/or patient module 24 (so as to receive a stimulation signal) through the use of the universal insulating assembly 38, the electrical coupler 35 (provided the tap member 39 is insulated in some manner) and/or by bringing a stimulation element into contact with the tap 15 member 39, such as by (for example) providing a longitudinal cannulation within the tap member 39 and disposing an electrically coupled K-wire 37 therein.

The control unit 22 includes a touch screen display 40 and a base 42, which collectively contain the essential processing capabilities for controlling the surgical 20 system 20. The patient module 24 is connected to the control unit 22 via a data cable 44, which establishes the electrical connections and communications (digital and/or analog) between the control unit 22 and patient module 24. The main functions of the control unit 22 include receiving user commands via the touch screen display 40, activating stimulation, processing signal data according to defined algorithms (described below), 25 displaying received parameters and processed data, and monitoring system status and reporting fault conditions. The touch screen display 40 is preferably equipped with a graphical user interface (GUI) capable of communicating information to the user and receiving instructions from the user. The display 40 and/or base 42 may contain patient module interface circuitry that commands the stimulation sources, receives digitized 30 signals and other information from the patient module 24, processes the EMG responses to extract characteristic information for each muscle group, and displays the processed data to the operator via the display 40.

As will be described in greater detail below, the surgical system 20 is capable of performing pedicle integrity assessments after the formation of the pilot hole, after preparation of the pilot hole, and/or after pedicle screw placement. Surgical system 20 accomplishes this by having the control unit 22 and patient module 24 cooperate to send stimulation signals to one or more stimulation electrodes or electrode regions on the various pedicle screw test accessories 30. Depending upon effect of pilot hole formation, pilot hole preparation and/or pedicle screw introduction (namely, on the bone forming the pedicle), the stimulation signals may cause nerves adjacent to or in the general proximity of the K-wire 37 and/or tap member 39 to innervate, which, in turn, can be monitored via the EMG harness 26. The pedicle integrity assessment feature of the present invention are based on assessing the evoked response of the various muscle myotomes monitored by the surgical system 20 via EMG harness 26.

The accessory handle assembly 36 includes a cable 55 for establishing electrical communication with the patient module 24 (via the accessory cable 32). In a preferred embodiment, each pedicle screw test accessory 30 (namely, K-wire insulator 34, universal insulating assembly 38, and electrical coupler 35) includes a proximal electrical connector 56, a distal electrical connector (described below), and an electrical cable 57 extending therebetween. The proximal electrical connector 56 is preferably threaded and designed to engage with the distal end 59 of the handle assembly 36. In this fashion, the screw test accessories 30 may be quickly and easily coupled (electrically and mechanically) to the accessory handle assembly 36. The distal electrical connector of the K-wire insulator 34 and universal insulating assembly 38 may comprise any number of suitable mechanisms for establishing electrical communication with an instrument passing therethrough (such as a K-wire 37 passing through the K-wire insulator 34 and/or the universal insulating assembly 38, and such as a tap member 39 extending through the universal insulating assembly 38). In a preferred embodiment, the distal electrical connectors within the universal insulating assembly 38 will be capable of expanding, moving or otherwise accommodating instruments of varying diameters according to the present invention. The distal electrical connector of the coupler 35 may include any number of suitable electrode or electrode regions (including protrusions) on or about the distal (or pinching) ends of the clamp arms 61 forming the coupler 35. Corresponding regions (such as electrodes or electrode regions – including indentations) may be provided on the K-wire 37, the tap member 39, such as where such devices are to be directly coupled to the handle assembly

36 (i.e. where K-wire 37 and/or tap member 39 are disposed through insulating elements that do not include distal electrical connectors) according to the present invention.

In all situations, the user may operate one or more buttons of the handle assembly 5 36 to selectively initiate a stimulation signal (preferably, a current signal) from the patient module 24 to the pedicle probe 56. With the K-wire 37 and/or tap member 39 touching the interior wall of the fully formed pilot hole and/or the K-wire 37 touching the fully introduced pedicle screw, applying a stimulation signal in this fashion serves to test the integrity of the medial wall of the pedicle. That is, a breach or compromise in the 10 integrity of the pedicle will allow the stimulation signal to pass through the pedicle and innervate an adjacent nerve root. By monitoring the myotomes associated with the nerve roots (via the EMG harness 26 and recording electrode 27) and assessing the resulting EMG responses (via the control unit 22), the surgical system 20 can assess whether a pedicle breach occurred during hole formation and/or screw introduction. If a breach or 15 potential breach is detected, the user may simply withdraw the misplaced pedicle screw and redirect to ensure proper placement.

FIG. 4 illustrates two exemplary manners of performing pedicle integrity assessments according to the present invention, one employing the K-wire insulator 34 20 and one employing the electrical coupler 35. With combined reference with FIG. 6, the K-wire insulator 34 according to the present invention includes an elongate insulating body 60 having a tapered distal end 63, open distal and proximal ends, and a lumen or cannulation extending therebetween dimensioned to receive and pass the K-wire 37. A cap element 64 is provided for placement in the proximal end of the insulating body 60. 25 The cap element 64 has a lumen therewithin dimensioned to pass the K-wire 37 and includes the distal electrical connector (not shown) coupled to the electrical cable 57. As shown in FIG. 4, the K-wire insulator 34 may be advanced to the pedicle target site in a percutaneous fashion, by either establishing a virgin approach to the pedicle target site or by passing through a previously established percutaneous corridor (such as may be left or 30 formed by commercially available percutaneous pedicle screw placement systems). This process may be facilitated by first establishing a pilot hole through the use of a so-called Jam-Sheede needle (comprising an inner rigid needle element disposed within a rigid outer needle element), after which point the inner rigid needle element is removed such that the K-wire 37 may be introduced into the pilot hole. The outer rigid needle element

of the Jam-Sheede device may then be removed, leaving the K-wire 37 in place. The K-wire insulator 34 may then be advanced over the K-wire 37. Once the distal end 63 of the K-wire insulator 34 abuts the opening of the pedicle pilot hole, buttons 64 on the handle member 36 may be employed to apply the stimulation signal to the K-wire 37. In this fashion, the majority of the K-wire 37 is insulated from the surrounding tissue, while the distal end of the K-wire 37 may be brought into direct contact with the pilot hole to perform pedicle integrity assessments according to one embodiment of the present invention. As will be appreciated, this same technique could be employed to bring the stimulation electrode or electrode region of the K-wire 37 into contact with a portion of a fully inserted pedicle screw (not shown).

FIG. 4 also illustrates that the electrical coupler 35 may be employed to perform pedicle integrity assessments, by way of example only, by establishing electrical communication between the fully inserted tap member 39 and the interior surface of the now-prepared pilot hole. The electrical coupler 35 accomplishes this by engaging the electrode or electrode regions on the opposing clamping arms 61 against a portion of the proximal end of the tap member 39. To facilitate this, the tap member 39 may be equipped with indentations or similar features for matingly engaging with corresponding features on the distal regions of the clamping arms 61. In the embodiment shown, an insulated cannula 66 is provided for insulating all but the exposed distal and proximal ends of the tap member 39. As with the body 60 of the K-wire insulator 34, the insulated cannula 66 is preferably equipped with a tapered distal end 67. In use, the tap member 39 will be advanced through the insulated cannula 66 (such as by being passed over a K-wire 37 via an internal cannulation) and rotated to prepare threads along the interior of the pilot hole. After the pilot hole has been fully prepared in this fashion (that is, to the full or approximately full depth of the pilot hole), the handle member 36 may be used to apply the stimulation signal to the electrical coupler 35 which, in turn, transmits this stimulation signal to the interior of the prepared pilot hole to perform pedicle integrity assessments according to another embodiment of the present invention. If the pedicle has not been breached, the tap member 39 may then be removed and a pedicle screw introduced into the prepared pilot hole. By selecting a pedicle screw having the same approximate characteristics (i.e. pitch, thread height, diameter, length, etc...) as the tapping (distal) portion of the tap member 39, the need to perform further pedicle integrity assessments after full introduction of the pedicle screw may be obviated.

FIG. 5 illustrates two more exemplary manners of performing pedicle integrity assessments according to the present invention, one employing the universal insulating assembly 38 and one employing the electrical coupler 35. With combined reference to FIGS. 7-11, the universal insulating assembly 38 includes a handle assembly 68 and an insulated cannula 70 extending from the distal portion of the handle assembly 68. As best seen in FIG. 7, the handle assembly 68 includes a housing member 71 and an electrical connector port 72 for connection with the electrical cable 57. With reference to FIG. 8, the housing member 71 contains a universal electrical coupling mechanism 73 comprising, by way of example, a plurality of contact elements 74 (in this case springs extending between posts 75). A lumen 76 is provided (by way of example only) in the approximate center of (and extending between) upper and lower base members 77. The contact elements 74 are positioned in a transverse fashion such that they intersect generally in the same plane as the center of the lumen 76. In this fashion, any metallic or conductive instrument passed through the lumen 76 will be brought into contact with the contact elements 74, thereby providing the ability to apply an electrical signal to the instrument. Moreover, the contact elements 74 are capable of moving, expanding, or otherwise accommodating instruments having a variety of diameters. As best shown in FIGS. 9-11, the insulated cannula 70 may be provided having any number of different lengths and widths, depending upon the device to be passed through it. A threaded base member 78 is preferably coupled to each insulated cannula 70 to facilitate coupling the particular insulated cannula 70 to a corresponding threaded portion on the distal region of the housing member 71. In this fashion, a surgeon may quickly and easily change between any of a variety of insulating cannulas 70 depending upon the application (i.e. depth to the pedicle target site) and the device to be passed therethrough (i.e. the tap member 39 as shown in FIG. 5).

The insulating cannula 70 serves to isolate a portion of the instrument as it is passed through the handle assembly 68. In this fashion, the insulating cannula 70 may be advanced to a pedicle target site, such as to the opening of a pedicle pilot hole as shown in FIG. 5. Although not shown, it is to be readily appreciated that the present invention also contemplates advancing the distal end of the insulating cannula 70 over or in general abutment with a proximal portion of a percutaneously placed pedicle screw pedicle screw. In either instance, an instrument or device (such as, by way of example, K-wire 37 or the tap member 39, depending upon the situation) may be passed through the handle

member 68 until the tip of the instrument reaches either the initially formed pilot hole, the fully prepared pilot hole, and/or the fully introduced pedicle screw. The insulating cannulas 70 are of varying size depending upon the particular target site and surgical application, but may preferably be provided ranging from 0 inches to 24 inches in length and of any diameter suitable to pass the instrument of interest.

FIG. 5 also illustrates a variant of the embodiment shown in FIG. 4, except that the insulated cannula 66 is specifically dimensioned to pass the K-wire 37, as opposed to larger diameter instruments such as the tap member 39 as shown in FIG. 4. In this instance, the electrical coupler 35 may be used to establish electrical communication between the K-wire 37 and the interior of a pilot hole. With the distal end of the K-wire 37 in such electrical communication with the interior of the pilot hole, the handle assembly 36 may be employed to apply the stimulation signal to perform a pedicle integrity assessment according to the present invention. Placement of the K-wire 37 within the pilot hole, and the advancement of the insulated cannula 66, may be the same as described above with reference to the Jam-Sheede device described above.

As noted above, the system 20 described generally above is exemplary of a system including a stimulation source and monitoring capacity for use in performing pedicle integrity assessment according to the present invention. It will be appreciated by those skilled in the art, however, that any number of systems for providing a stimulation signal and for monitoring to assess pedicle breach may be employed without departing from the scope of the present invention. That said, the following discussion elaborates on the particular algorithms and principles behind the neurophysiology for performing pedicle integrity assessments according to the exemplary embodiment shown (system 20 of FIGS. 2-3) according to the present invention.

FIGS. 12 and 13 illustrate a fundamental aspect of the present invention: a stimulation signal (FIG. 12) and a resulting evoked response (FIG. 13). By way of example only, the stimulation signal is preferably a stimulation current signal (I_{stim}) having rectangular monophasic pulses with a frequency and amplitude adjusted by system software. In a still further preferred embodiment, the stimulation current (I_{stim}) may be coupled in any suitable fashion (i.e. AC or DC) and comprises rectangular monophasic pulses of 200 microsecond duration. The amplitude of the current pulses may be fixed,

but will preferably sweep from current amplitudes of any suitable range, such as from 2 to 100 mA. For each nerve and myotome there is a characteristic delay from the stimulation current pulse to the EMG response (typically between 5 to 20 ms). To account for this, the frequency of the current pulses is set at a suitable level such as, in a preferred embodiment, 4 Hz to 10 Hz (and most preferably 4.5 Hz), so as to prevent stimulating the nerve before it has a chance to recover from depolarization. The EMG response shown in FIG. 13 can be characterized by a peak-to-peak voltage of $V_{pp} = V_{max} - V_{min}$.

FIG. 14 illustrates an alternate manner of setting the maximum stimulation frequency, to the extent it is desired to do so rather than simply selecting a fixed maximum stimulation frequency (such as 4.5 Hz) as described above. According to this embodiment, the maximum frequency of the stimulation pulses is automatically adjusted. After each stimulation, F_{max} will be computed as: $F_{max} = 1/(T2 + T_{Safety\ Margin})$ for the largest value of T2 from each of the active EMG channels. In one embodiment, the Safety Margin is 5 ms, although it is contemplated that this could be varied according to any number of suitable durations. Before the specified number of stimulations, the stimulations will be performed at intervals of 100-120 ms during the bracketing state, intervals of 200-240 ms during the bisection state, and intervals of 400-480 ms during the monitoring state. After the specified number of stimulations, the stimulations will be performed at the fastest interval practical (but no faster than F_{max}) during the bracketing state, the fastest interval practical (but no faster than $F_{max}/2$) during the bisection state, and the fastest interval practical (but no faster than $F_{max}/4$) during the monitoring state. The maximum frequency used until F_{max} is calculated is preferably 10Hz, although slower stimulation frequencies may be used during some acquisition algorithms. The value of F_{max} used is periodically updated to ensure that it is still appropriate. For physiological reasons, the maximum frequency for stimulation will be set on a per-patient basis. Readings will be taken from all myotomes and the one with the slowest frequency (highest T2) will be recorded.

A basic premise behind the neurophysiology employed in the present invention is that each nerve has a characteristic threshold current level (I_{Thresh}) at which it will depolarize. Below this threshold, current stimulation will not evoke a significant EMG response (V_{pp}). Once the stimulation threshold (I_{Thresh}) is reached, the evoked response is reproducible and increases with increasing stimulation until saturation is reached. This

relationship between stimulation current and EMG response may be represented graphically via a so-called "recruitment curve," such as shown in FIG. 15, which includes an onset region, a linear region, and a saturation region. By way of example only, the present invention defines a significant EMG response to have a Vpp of approximately 5 100 uV. In a preferred embodiment, the lowest stimulation current that evokes this threshold voltage (V_{Thresh}) is called I_{Thresh} . As will be described in greater detail below, changes in the current threshold (I_{Thresh}) may be indicative of a change in the degree of electrical communication between a stimulation electrode and a nerve. This is helpful in assessing if a screw or similar instrument has inadvertently breached the cortex of a 10 pedicle. More specifically, where an initial determination of (I_{Thresh}), such as by applying a stimulation current to the interior of a hole created to receive a pedicle screw, is greater than a later determination of (I_{Thresh}), such as by applying a stimulation current to the tip of the pedicle screw after insertion, the decrease in I_{Thresh} , if large enough, may indicate electrical communication between the pedicle screw and the nerve. Based on the 15 insulation properties of bone, such electrical communication would indicate a breach of the pedicle.

In order to obtain this useful information, the present invention must first identify the peak-to-peak voltage (Vpp) of each EMG response corresponding a given stimulation 20 current (I_{Stim}). The existence stimulation and/or noise artifacts, however, can conspire to create an erroneous Vpp measurement of the electrically evoked EMG response. To overcome this challenge, the surgical system 20 of the present invention may employ any number of suitable artifact rejection techniques, including the traditional stimulation artifact rejection technique shown in FIG. 16. Under this technique, stimulation artifact 25 rejection is undertaken by providing a simple artifact rejection window $T1_{WIN}$ at the beginning of the EMG waveform. During this $T1$ window, the EMG waveform is ignored and Vpp is calculated based on the max and min values outside this window. ($T1$ is the time of the first extremum (min or max) and $T2$ is the time of the second extremum.) In one embodiment, the artifact rejection window $T1_{WIN}$ may be set to about 30 7.3 msec. While generally suitable, there are situations where this stimulation artifact rejection technique of FIG. 16 is not optimum, such as in the presence of a large stimulation artifact (see FIG. 17). The presence of a large stimulation artifact causes the stimulation artifact to cross over the window $T1_{WIN}$ and blend in with the EMG. Making

the stimulation artifact window larger is not effective, since there is no clear separation between EMG and stimulation artifact.

FIG. 18 illustrates a stimulation artifact rejection technique according to the present invention, which solves the above-identified problem with traditional stimulation artifact rejection. Under this technique, a T1 validation window ($T1-V_{WIN}$) is defined immediately following the T1 window ($T1_{WIN}$). If the determined V_{pp} exceeds the threshold for recruiting, but T1 falls within this T1 validation window, then the stimulation artifact is considered to be substantial and the EMG is considered to have not recruited. An operator may be alerted, based on the substantial nature of the stimulation artifact. This method of stimulation artifact rejection is thus able to identify situations where the stimulation artifact is large enough to cause the V_{pp} to exceed the recruit threshold. To account for noise, the T1 validation window ($T1-V_{WIN}$) should be within the range of 0.1 ms to 1 ms wide (preferably about 0.5 ms). The T1 validation window ($T1-V_{WIN}$) should not be so large that the T1 from an actual EMG waveform could fall within.

FIG. 19 illustrates a noise artifact rejection technique according to the present invention. When noise artifacts fall in the time window where an EMG response is expected, their presence can be difficult to identify. Artifacts outside the expected response window, however, are relatively easy to identify. The present invention capitalizes on this and defines a T2 validation window ($T2-V_{WIN}$) analogous to the T1 validation window ($T1-V_{WIN}$) described above with reference to FIG. 18. As shown, T2 must occur prior to a defined limit, which, according to one embodiment of the present invention, may be set having a range of between 40 ms to 50 ms (preferably about 47 ms). If the V_{pp} of the EMG response exceeds the threshold for recruiting, but T2 falls beyond the T2 validation window ($T2-V_{WIN}$), then the noise artifact is considered to be substantial and the EMG is considered to have not recruited. An operator may be alerted, based on the substantial nature of the noise artifact.

FIG. 20 illustrates a still further manner of performing stimulation artifact rejection according to an alternate embodiment of the present invention. This artifact rejection is premised on the characteristic delay from the stimulation current pulse to the EMG response. For each stimulation current pulse, the time from the current pulse to the

first extremum (max or min) is T_1 and to the second extremum (max or min) is T_2 . As will be described below, the values of T_1 , T_2 are each compiled into a histogram period (see FIG. 21). New values of T_1 , T_2 are acquired for each stimulation and the histograms are continuously updated. The value of T_1 and T_2 used is the center value of the largest bin in the histogram. The values of T_1 , T_2 are continuously updated as the histograms change. Initially V_{pp} is acquired using a window that contains the entire EMG response. After 20 samples, the use of T_1 , T_2 windows is phased in over a period of 200 samples. V_{max} and V_{min} are then acquired only during windows centered around T_1 , T_2 with widths of, by way of example only, 5 msec. This method of acquiring V_{pp} automatically rejects the artifact if T_1 or T_2 fall outside of their respective windows.

Having measured each V_{pp} EMG response (as facilitated by the stimulation and/or noise artifact rejection techniques described above), this V_{pp} information is then analyzed relative to the stimulation current in order to determine a relationship between the nerve and the given stimulation element transmitting the stimulation current. More specifically, the present invention determines these relationships (between nerve and the stimulation element) by identifying the minimum stimulation current (I_{Thresh}) capable of resulting in a predetermined V_{pp} EMG response. According to the present invention, the determination of I_{Thresh} may be accomplished via any of a variety of suitable algorithms or techniques.

FIGS. 22A-22E illustrate, by way of example only, a threshold-hunting algorithm for quickly finding the threshold current (I_{Thresh}) for each nerve being stimulated by a given stimulation current (I_{stim}). Threshold current (I_{Thresh}), once again, is the minimum stimulation current (I_{stim}) that results in a V_{pp} that is greater than a known threshold voltage (V_{Thresh}). The value of is adjusted by a bracketing method as follows. The first bracket is 0.2 mA and 0.3mA. If the V_{pp} corresponding to both of these stimulation currents is lower than V_{Thresh} , then the bracket size is doubled to 0.2mA and 0.4mA. This doubling of the bracket size continues until the upper end of the bracket results in a V_{pp} that is above V_{Thresh} . The size of the brackets is then reduced by a bisection method. A current stimulation value at the midpoint of the bracket is used and if this results in a V_{pp} that is above V_{Thresh} , then the lower half becomes the new bracket. Likewise, if the midpoint V_{pp} is below V_{Thresh} then the upper half becomes the new bracket. This bisection method is used until the bracket size has been reduced to I_{Thresh}

mA. I_{Thresh} may be selected as a value falling within the bracket, but is preferably defined as the midpoint of the bracket.

The threshold-hunting algorithm of this embodiment will support three states:
5 bracketing, bisection, and monitoring. A stimulation current bracket is a range of stimulation currents that bracket the stimulation current threshold I_{Thresh} . The width of a bracket is the upper boundary value minus the lower boundary value. If the stimulation current threshold I_{Thresh} of a channel exceeds the maximum stimulation current, that threshold is considered out-of-range. During the bracketing state, threshold hunting will
10 employ the method below to select stimulation currents and identify stimulation current brackets for each EMG channel in range.

The method for finding the minimum stimulation current uses the methods of bracketing and bisection. The "root" is identified for a function that has the value -1 for
15 stimulation currents that do not evoke adequate response; the function has the value +1 for stimulation currents that evoke a response. The root occurs when the function jumps from -1 to +1 as stimulation current is increased: the function never has the value of precisely zero. The root will not be known exactly, but only with a level of precision related to the minimum bracket width. The root is found by identifying a range that must
20 contain the root. The upper bound of this range is the lowest stimulation current I_{Thresh} where the function returns the value +1, i.e. the minimum stimulation current that evokes response. The lower bound of this range is the highest stimulation current I_{Thresh} where the function returns the value -1, i.e. the maximum stimulation current that does not evoke a response.

25 The pedicle integrity assessment function may begin by adjusting the stimulation current until the root is bracketed (FIG. 22B). The initial bracketing range may be provided in any number of suitable ranges. In one embodiment, the initial bracketing range is 0.2 to 0.3 mA. If the upper stimulation current does not evoke a response, the
30 upper end of the range should be increased. The range scale factor is 2. The stimulation current should preferably not be increased by more than 10 mA in one iteration. The stimulation current should preferably never exceed the programmed maximum stimulation current. For each stimulation, the algorithm will examine the response of each

active channel to determine whether it falls within that bracket. Once the stimulation current threshold of each channel has been bracketed, the algorithm transitions to the bisection state.

5 During the bisection state (FIGS. 22C and 22D), threshold hunting will employ the method described below to select stimulation currents and narrow the bracket to a selected width (for example, 0.1 mA) for each EMG channel with an in-range threshold. After the minimum stimulation current has been bracketed (FIG. 22B), the range containing the root is refined until the root is known with a specified accuracy. The
10 bisection method is used to refine the range containing the root. In one embodiment, the root should be found to a precision of 0.1 mA. During the bisection method, the stimulation current at the midpoint of the bracket is used. If the stimulation evokes a response, the bracket shrinks to the lower half of the previous range. If the stimulation fails to evoke a response, the bracket shrinks to the upper half of the previous range. The
15 proximity algorithm is locked on the electrode position when the response threshold is bracketed by stimulation currents separated by the selected width (i.e. 0.1 mA). The process is repeated for each of the active channels until all thresholds are precisely known. At that time, the algorithm enters the monitoring state.

20 After identifying the threshold current I_{Thresh} , this information may be employed to determine any of a variety of relationships between the screw test accessory and the nerve. For example, as will be described in greater detail below, when determining the current threshold I_{Thresh} of a nerve during pedicle integrity assessment, the relationship between the pedicle testing assembly 36 and the nerve is whether electrical
25 communication is established therebetween. If electrical communication is established, this indicates that the medial wall of the pedicle has been cracked, stressed, or otherwise breached as a result of pilot hole formation, pilot hole preparation, and/or screw introduction. If not, this indicates that the integrity of the medial wall of the pedicle has remained intact. This characteristic is based on the insulating properties of bone.

30 In a significant aspect of the present invention, the relationships determined above based on the current threshold determination may be communicated to the user in an easy to use format, including but not limited to, alpha-numeric and/or graphical information regarding pedicle integrity assessments, stimulation level, EMG responses, instrument in

use, set-up, and related instructions for the user. This advantageously provides the ability to present simplified yet meaningful data to the user, as opposed to the actual EMG waveforms that are displayed to the users in traditional EMG systems. Due to the complexity in interpreting EMG waveforms, such prior art systems typically require an additional person specifically trained in such matters which, in turn, can be disadvantageous in that it translates into extra expense (having yet another highly trained person in attendance) and oftentimes presents scheduling challenges because most hospitals do not retain such personnel.

When employed in spinal procedures, for example, such EMG monitoring would preferably be accomplished by connecting the EMG harness 26 to the myotomes in the patient's legs corresponding to the exiting nerve roots associated with the particular spinal operation level. In a preferred embodiment, this is accomplished via 8 pairs of EMG electrodes 27 placed on the skin over the major muscle groups on the legs (four per side), an anode electrode 29 providing a return path for the stimulation current, and a common electrode 31 providing a ground reference to pre-amplifiers in the patient module 24. Although not shown, it will be appreciated that any of a variety of electrodes can be employed, including but not limited to needle electrodes. The EMG responses measured via the EMG harness 26 provide a quantitative measure of the nerve depolarization caused by the electrical stimulus. By way of example, the placement of EMG electrodes 27 may be undertaken according to the manner shown in Table 1 below for spinal surgery:

Table 1

| Color | Channel ID | Myotome | Spinal Level |
|--------|------------|-------------------------|--------------|
| Blue | Right 1 | Right Vastus Medialis | L2, L3, L4 |
| Violet | Right 2 | Right Tibialis Anterior | L4, L5 |
| Grey | Right 3 | Right Biceps Femoris | L5, S1, S2 |
| White | Right 4 | Right Gastroc. Medial | S1, S2 |
| Red | Left 1 | Left Vastus Medialis | L2, L3, L4 |
| Orange | Left 2 | Left Tibialis Anterior | L4, L5 |
| Yellow | Left 3 | Left Biceps Femoris | L5, S1, S2 |
| Green | Left 4 | Left Gastroc. Medial | S1, S2 |

With reference again to FIGS. 2-3, the surgical system 20 performs pedicle integrity assessments via, by way of example only, the use of pedicle testing accessories 30 in combination with the handle assembly 36. More specifically, upon pressing the button on the screw test handle 36, the software will execute a testing algorithm to apply a stimulation current to the particular target (i.e. pilot hole, inserted pedicle screw, or bare nerve), setting in motion the pedicle integrity assessment function of the present invention. The pedicle integrity assessment features of the present invention may include, by way of example only, an "Actual" mode (FIGS. 24-25) for displaying the actual stimulation threshold 91 measured for a given myotome, as well as a "Relative" mode (FIGS. 26-28) for displaying the difference 92 between a baseline stimulation threshold assessment 93 of a bare nerve root and an actual stimulation threshold assessment 91 for a given myotome. In either case, the surgical accessory label 84 displays the word "SCREW TEST" to denote use of the pedicle testing assembly 36 for performing pedicle integrity assessments. The screw test algorithm according to the present invention preferably determines the depolarization (threshold) current for all responding EMG channels. In one embodiment, the EMG channel tabs 82 may be configured such that the EMG channel having the lowest stimulation threshold will be automatically enlarged and/or highlighted and/or colored (EMG channel tab R3 as shown in FIG. 24) to clearly indicate this fact to the user. As shown in FIG. 25, this feature may be overridden by manually selecting another EMG channel tab (such as EMG channel tab R1 in FIG. 25) by touching the particular EMG channel tab 82 on the touch screen display 40. In this instance, a warning symbol 94 may be provided next to the EMG channel tab having the lowest stimulation threshold (once again, EMG channel tab R3 in FIG. 24) to inform the user that the stimulation threshold 91 is not the lowest stimulation threshold.

Any number of the above-identified indicia (such as the baseline stimulation 93, actual stimulation 91, difference 92, and EMG channel tabs 82) may be color-coded to indicate general safety ranges (i.e. "green" for a range of stimulation thresholds above a predetermined safe value, "red" for range of stimulation thresholds below a predetermined unsafe value, and "yellow" for the range of stimulation thresholds in between the predetermined safe and unsafe values – designating caution). In one embodiment, "green" denotes a stimulation threshold range of 9 milliamps (mA) or greater, "yellow" denotes a stimulation threshold range of 6-8 mA, and "red" denotes a stimulation threshold range of 6 mA or below. By providing this information graphically,

a surgeon may quickly and easily test to determine if the integrity of a pedicle has been breached or otherwise compromised, such as may result due to the formation of a pedicle screw hole and/or introduction of a pedicle screw. More specifically, if after stimulating the screw hole and/or pedicle screw itself the stimulation threshold is: (a) at or below 6
5 mA, the threshold display 40 will illuminate "red" and thus indicate to the surgeon that a breach is likely; (b) between 6 and 8 mA, the threshold display 40 will illuminate
"yellow" and thus indicate to the surgeon that a breach is possible; and/or (c) at or above
8 mA, the threshold display 40 will illuminate "green" and thus indicate to the surgeon
10 that a breach is unlikely. If a breach is possible or likely (that is, "yellow" or "red"), the
surgeon may choose to withdraw the pedicle screw and redirect it along a different
trajectory to ensure the pedicle screw no longer breaches (or comes close to breaching)
the medial wall of the pedicle.

While this invention has been described in terms of a best mode for achieving this
15 invention's objectives, it will be appreciated by those skilled in the art that variations may
be accomplished in view of these teachings without deviating from the spirit or scope of
the present invention. For example, the present invention may be implemented using any
combination of computer programming software, firmware or hardware. As a preparatory
step to practicing the invention or constructing an apparatus according to the invention,
20 the computer programming code (whether software or firmware) according to the
invention will typically be stored in one or more machine readable storage mediums such
as fixed (hard) drives, diskettes, optical disks, magnetic tape, semiconductor memories
such as ROMs, PROMs, etc., thereby making an article of manufacture in accordance
with the invention. The article of manufacture containing the computer programming
25 code is used by either executing the code directly from the storage device, by copying the
code from the storage device into another storage device such as a hard disk, RAM, etc.
or by transmitting the code on a network for remote execution. As can be envisioned by
one of skill in the art, many different combinations of the above may be used and
accordingly the present invention is not limited by the scope of the appended claims.
30

The claims defining the invention are as follows:

1. A method for performing percutaneous pedicle integrity assessments during spine surgery, comprising the steps of:
 - 5 (a) percutaneously introducing one of an insulated K-wire and an insulated shaft of a pedicle screw pilot hole preparation tool to a pedicle target site;
 - (b) establishing electrical communication between a stimulation element and an interior of a pedicle screw pilot hole;
 - (c) applying a stimulation signal to said stimulation element; and
 - 10 (d) monitoring to assess whether nerves adjacent said pedicle are innervating as a result of the step of applying said stimulation signal to said stimulation element.
2. The method of claim 1 and further, wherein said pedicle target site comprises at
15 least one of a fully inserted pedicle screw and the opening of at least one of an initially formed pedicle screw pilot hole and a prepared pedicle screw pilot hole.
3. The method of claim 1 and further, wherein said one of said K-wire and said pedicle screw pilot hole preparation tool is insulated via one of an insulative coating
20 formed about said K-wire or pilot hole preparation tool and an elongate insulative body disposed around said K-wire or pilot hole preparation tool.
4. The method of claim 1 and further, wherein step (b) of establishing electrical
25 communication between said stimulation element and said interior of said pedicle screw pilot hole is accomplished by at least one of: (i) disposing said K-wire such that an exposed distal tip of said K-wire contacts a fully inserted pedicle screw; and (ii) disposing said K-wire such that an exposed distal tip of said K-wire contacts said pedicle screw pilot hole.
- 30 5. The method of claim 1 and further, wherein step (b) of establishing electrical communication between said stimulation element and said interior of said pedicle screw pilot hole is accomplished by: (i) introducing said pedicle screw pilot hole preparation tool into a pedicle screw pilot hole; and (ii) establishing electrical

communication between said stimulation element and said pedicle screw pilot hole preparation tool.

5 6. The method of claim 5 and further, wherein said stimulation element is a K-wire, and wherein said pedicle screw pilot hole preparation tool is provided with a longitudinal lumen for receiving and passing said K-wire therethrough.

10 7. The method of claim 5, wherein electrical communication between said stimulation element and said pedicle screw pilot hole preparation tool is established by attaching said stimulation element to a proximal end of said pedicle screw pilot hole preparation tool.

15 8. The method of claim 7 and further, wherein said stimulation element is a clamp style coupler.

9. The method of claim 1 and further, wherein said pedicle screw pilot hole preparation tool is a tap member.

20 10. The method of claim 1 and further, wherein said stimulation element is an electric coupling device that attaches to a proximal end of one of said k-wire and said pedicle screw pilot hole preparation tool.

25 11. The method of claim 2 and further, wherein said elongate insulative body disposed around said K-wire or pilot hole preparation tool includes an electrical coupling mechanism for establishing electrical contact between a stimulation source and said stimulation element.

30 12. The method of claim 10 and further, wherein said electric coupling device is a clamp style connector.

13. A method of performing percutaneous pedicle integrity assessments during spine surgery, comprising the steps of:

- (a) percutaneously introducing an insulated K-wire into contact with at least one of a pedicle screw and a pedicle screw pilot hole;
 - (b) applying a stimulation signal to said K-wire; and
 - (c) monitoring to assess whether nerves adjacent said pedicle are
- 5 innervating as a result of the step of applying said stimulation signal to said K-wire.

14. A method of performing percutaneous pedicle integrity assessments during spine surgery, comprising the steps of:
- (a) percutaneously introducing an insulated pedicle screw pilot hole
- 10 preparation tool to the approximate opening of a pedicle screw pilot hole;
- (b) applying a stimulation signal to said pedicle screw pilot hole preparation tool; and
 - (c) monitoring to assess whether nerves adjacent said pedicle are
- 15 innervating as a result of the step of applying said stimulation signal to said pedicle screw pilot hole preparation tool.

15. A method of performing percutaneous pedicle integrity assessments during spine surgery, comprising the steps of:
- (a) percutaneously introducing an insulated K-wire into contact with a
- 20 pedicle screw pilot hole;
- (b) applying a stimulation signal to said K-wire;
 - (c) monitoring to assess whether nerves adjacent said pedicle are
- innervating as a result of the step of applying said stimulation signal to said K-wire;
- (d) percutaneously introducing an insulated member to the approximate
- 25 opening of a pedicle screw pilot hole;
- (e) introducing a tap member through said insulated member to prepare said pedicle screw pilot hole;
 - (f) applying a stimulation signal to said tap member; and
 - (g) monitoring to assess whether nerves adjacent said pedicle are
- 30 innervating as a result of the step of applying said stimulation signal to said tap member.

16. A system for performing percutaneous pedicle integrity assessments during spine surgery, comprising:
an insulated K-wire configured for percutaneous introduction to a pedicle target site within a patient and having an uninsulated stimulation region at a distal end
- 5 configured for contacting at least one of a pilot hole formed in said pedicle and a screw implanted in said pedicle; and
- a stimulation source in electrical communication with said stimulation region for selectively applying a stimulation signal to said stimulation region to assess whether nerves adjacent said pedicle target site innervate as a result of applying said
- 10 stimulation signal to said region.
17. The system of claim 16 and further, wherein said K-wire is insulated via an insulative coating.
- 15 18. The system of claim 16 and further, wherein said K-wire is insulated via an elongate insulative body disposed around said K-wire.
19. The system of claim 18 and further, wherein said insulative body includes an electrical coupling mechanism for establishing electrical contact between said
- 20 stimulation source and said stimulation element.
20. The system of claim 17 or claim 18 and further, wherein said electrical coupling mechanism is a clip that attaches directly to an uninsulated portion near a proximal end of said K-wire.
- 25 21. The system of claim 16 and further, comprising an EMG monitoring system for assessing whether nerves adjacent said pedicle target site innervate as a result of applying said stimulation signal to said stimulation region.
- 30 22. The system of claim 21 and further, wherein said EMG monitoring system displays at least one of alpha-numeric and graphical information to a user regarding whether nerves adjacent said pedicle target site innervate as a result of applying said stimulation signal to said stimulation region.

23. A system for performing percutaneous pedicle integrity assessments during spine surgery, comprising:
- 5 a pedicle preparation tool with a shaft insulated along at least a portion positionable within a patient and configured for percutaneous introduction to a pedicle target site within said patient, said pedicle preparation tool having an uninsulated stimulation region at a distal end; and
 - 10 a stimulation source in electrical communication with said stimulation region for selectively applying a stimulation signal to said stimulation region to assess whether nerves adjacent said pedicle target site innervate as a result of applying said stimulation signal to said stimulation region.
24. The system of claim 23 and further, wherein said pedicle preparation tool is a tap.
- 15 25. The system of claim 23 and further wherein said pedicle preparation tool is insulated via an insulative coating.
26. The system of claim 23 and further, wherein said pedicle preparation tool is 20 insulated via an elongate insulative body disposed around said pedicle preparation tool.
27. The system of claim 26 and further, wherein said insulative body includes an electrical coupling mechanism for establishing electrical contact between said stimulation source and said stimulation region.
- 25 28. The system of claim 25 or 26 and further, wherein said electrical coupling mechanism is a clip that attaches directly to an uninsulated portion near a proximal end of pedicle preparation tool.
- 30 29. The system of claim 23 and further, comprising an EMG monitoring system for assessing whether nerves adjacent said pedicle target site innervate as a result of applying said stimulation signal to said pedicle preparation tool.

30. The system of claim 24 and further, wherein said EMG monitoring system displays at least one of alpha-numeric and graphical information to a user regarding whether nerves adjacent said pedicle target site innervate as a result of applying said stimulation signal to said stimulation region.
- 5
31. A method for performing percutaneous pedicle integrity assessments during spine surgery substantially as hereinbefore described with reference to the drawings.
- 10
32. A system for performing percutaneous pedicle integrity assessments during spine surgery substantially as hereinbefore described with reference to the drawings.

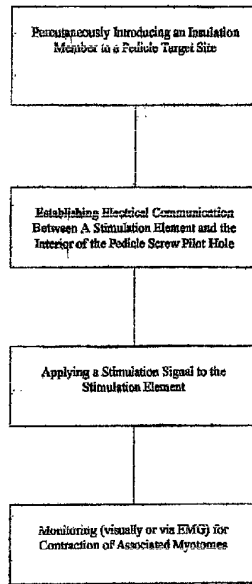

FIG. 1

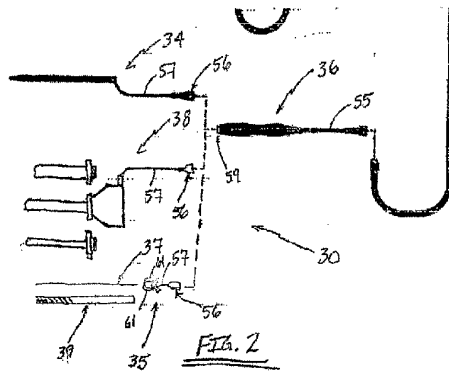

FIG. 2

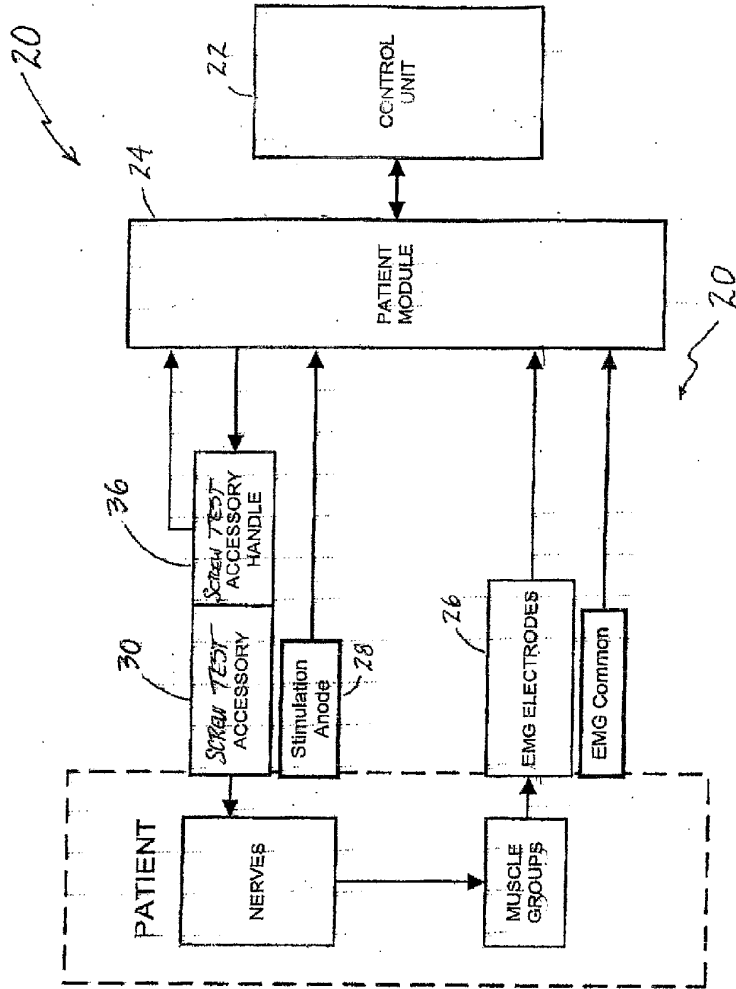

FIG. 3

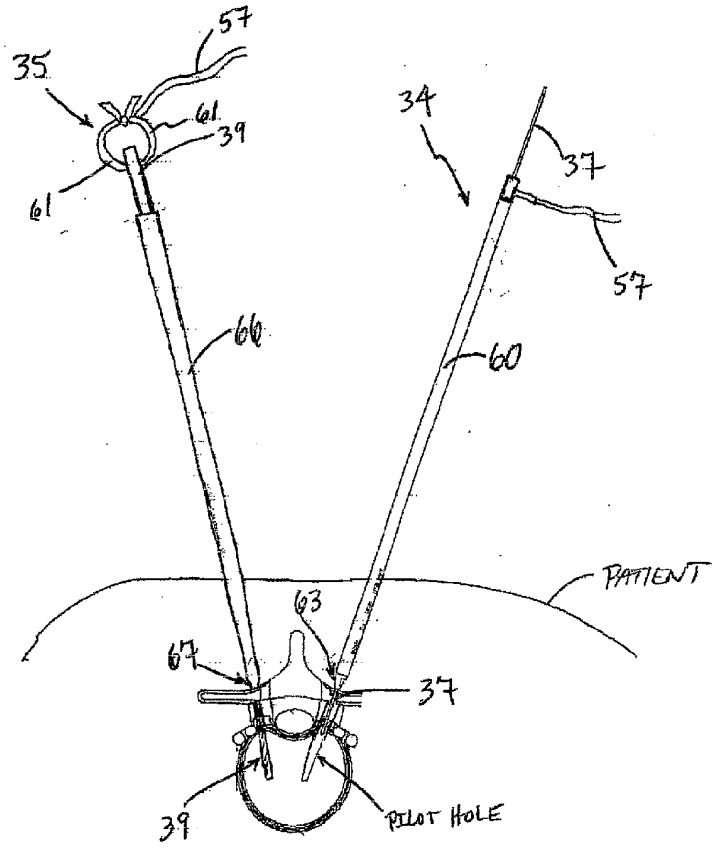

FIG. 4

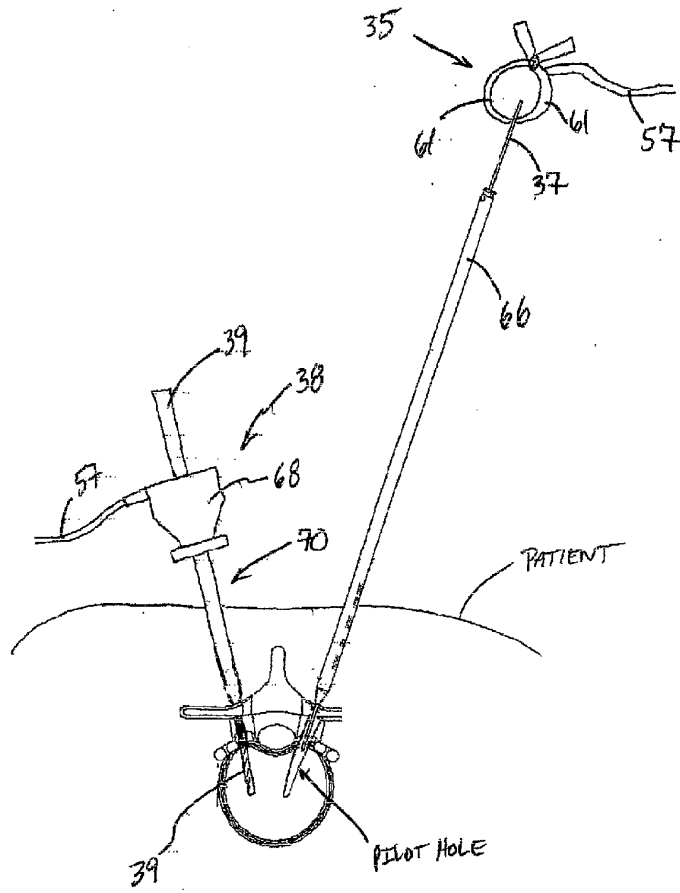

FIG. 5.

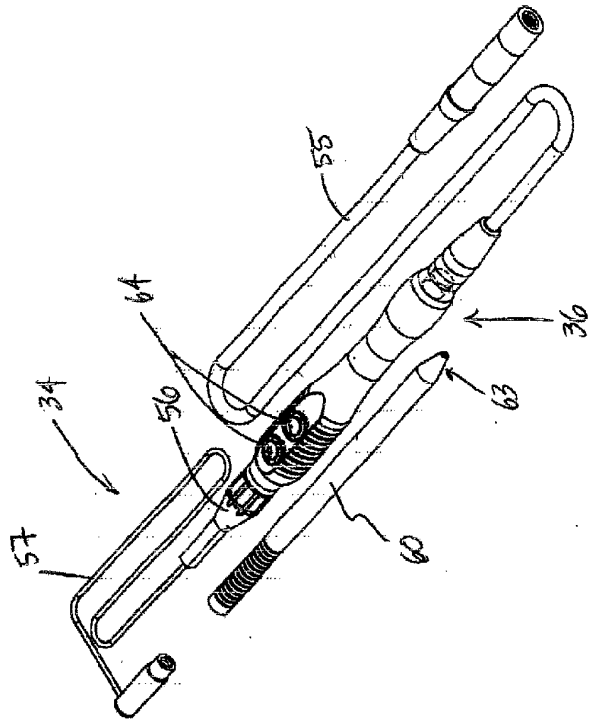
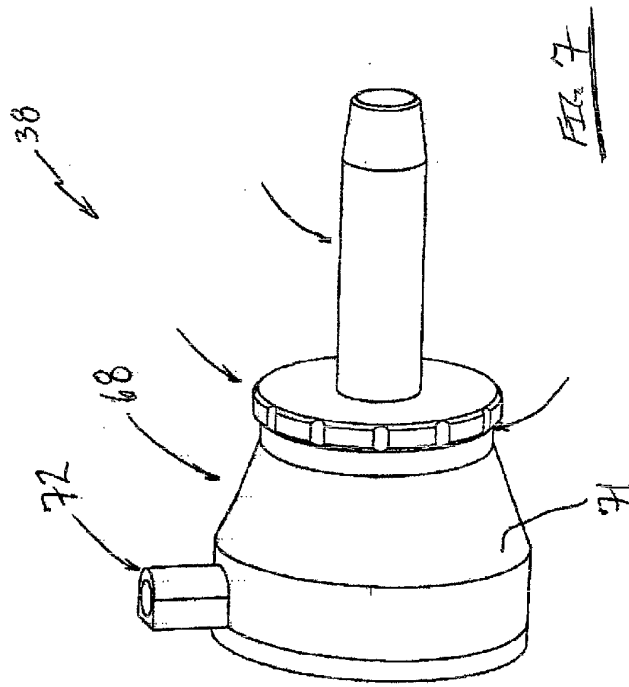
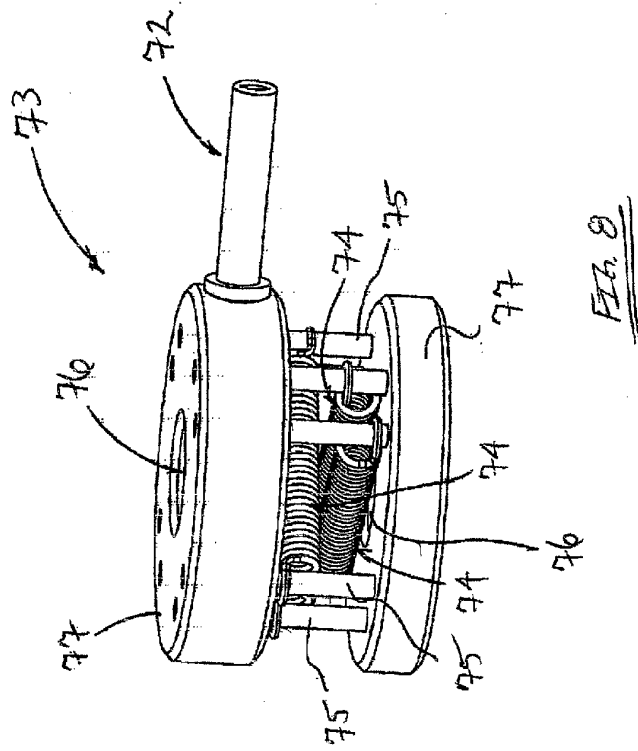
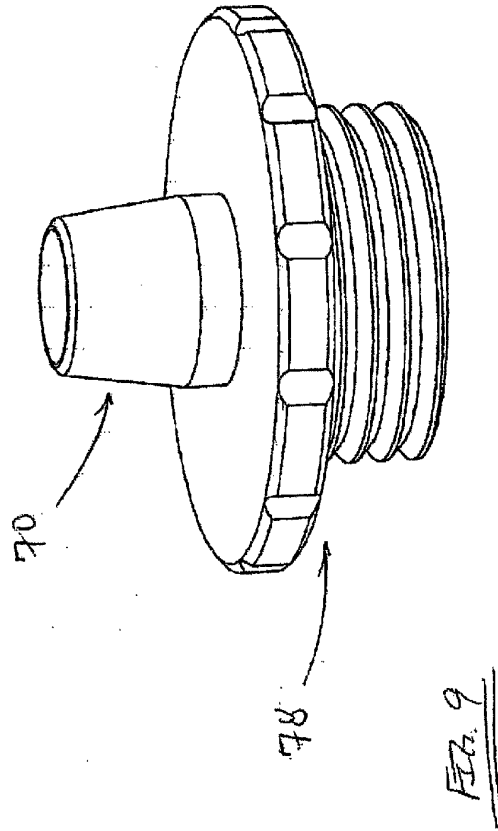

FIG. 6







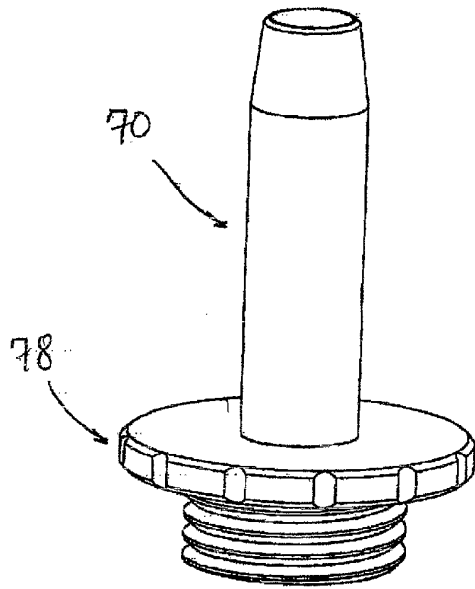

FIG. 10

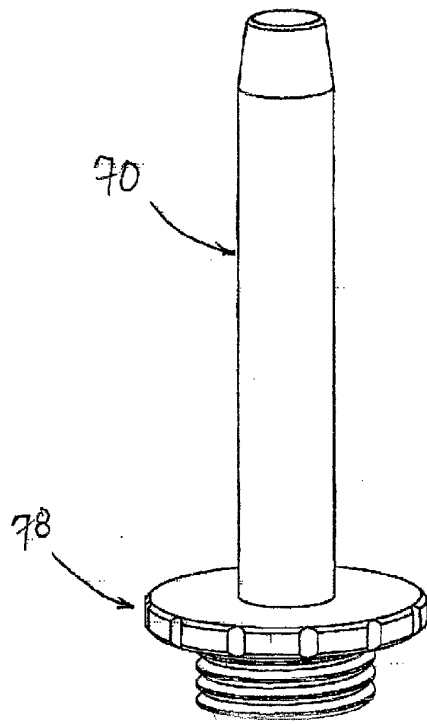

FIG. 11

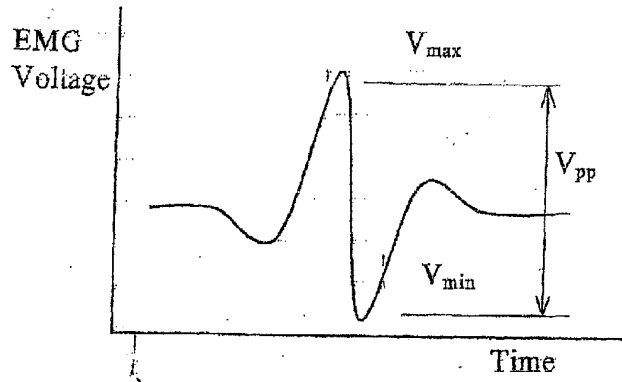

FIG. 13

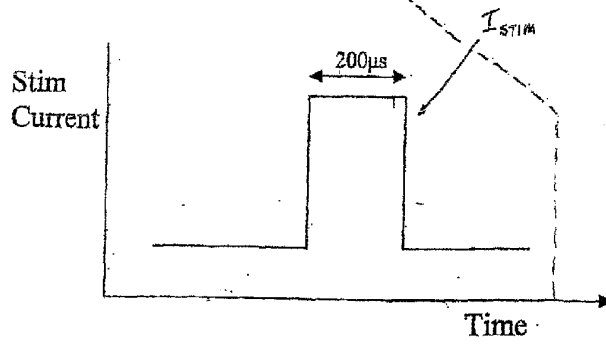

FIG. 12

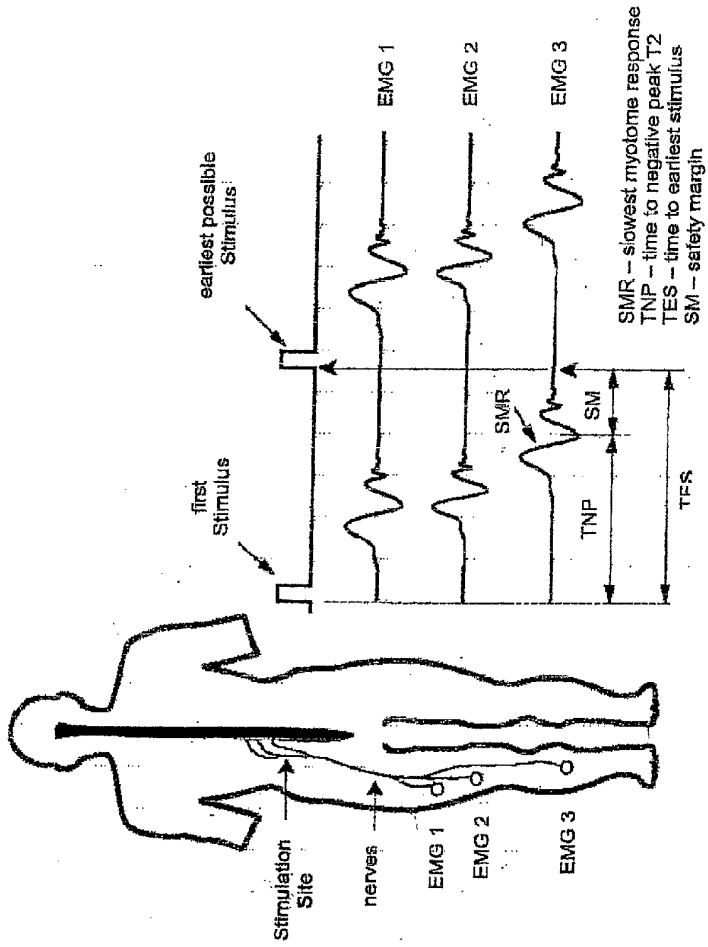

FIG. 14

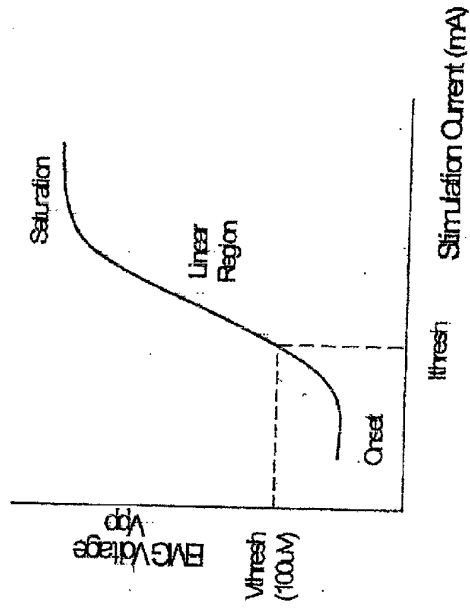

FIG. 15

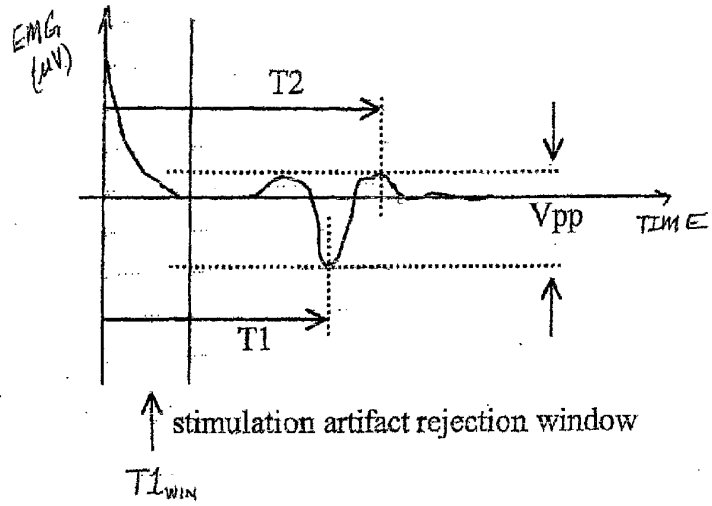

FIG. 16

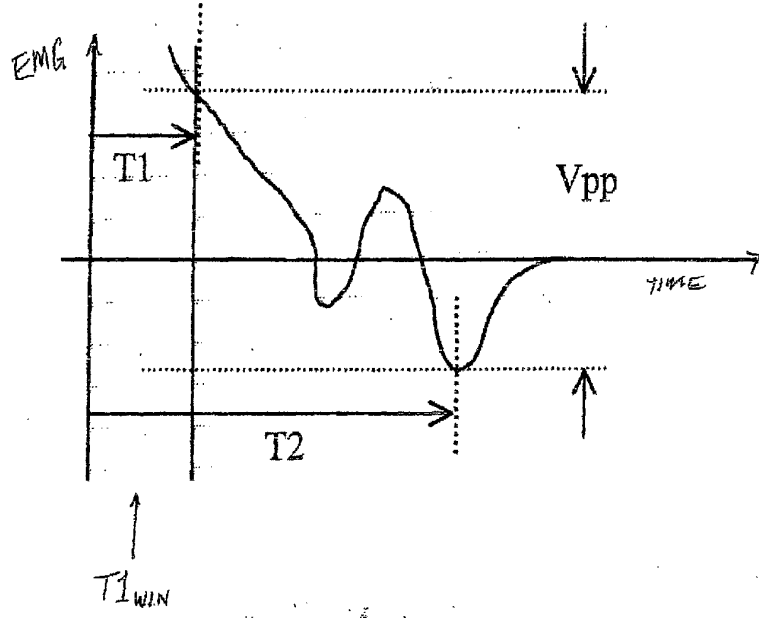

FIG. 17

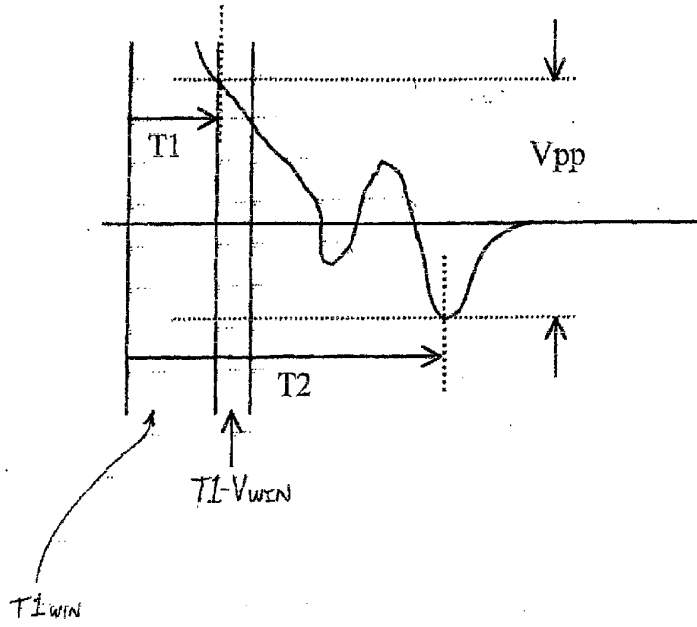

FIG. 18

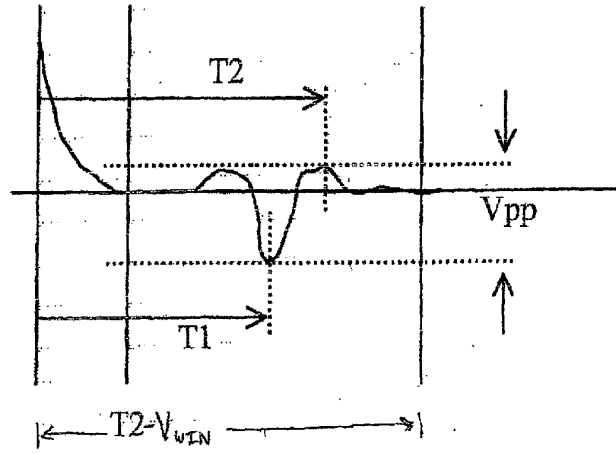

FIG. 19

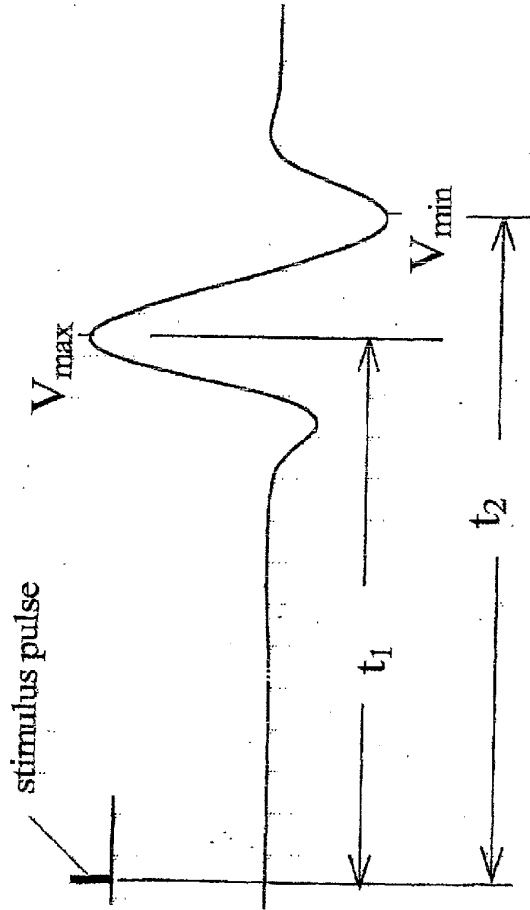

FIG. 20

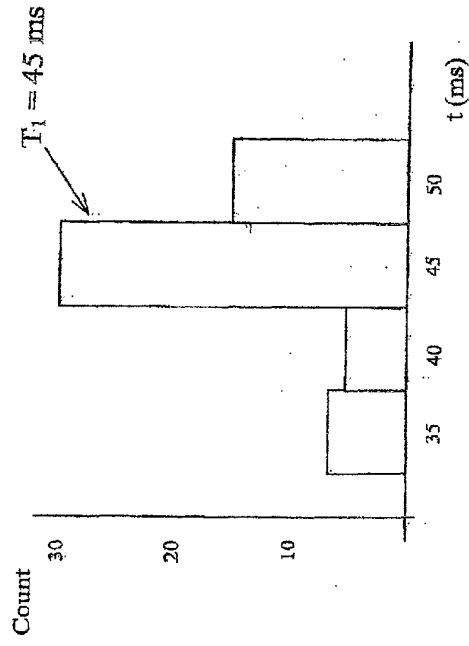

FIG. 21

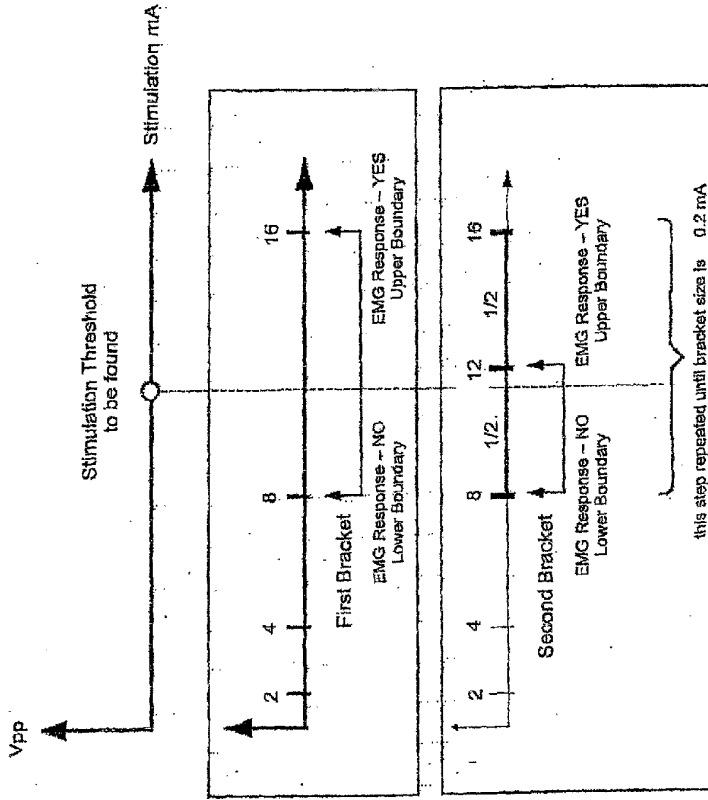

FIG. 22.A

FIG. 22.B

FIG. 22.C

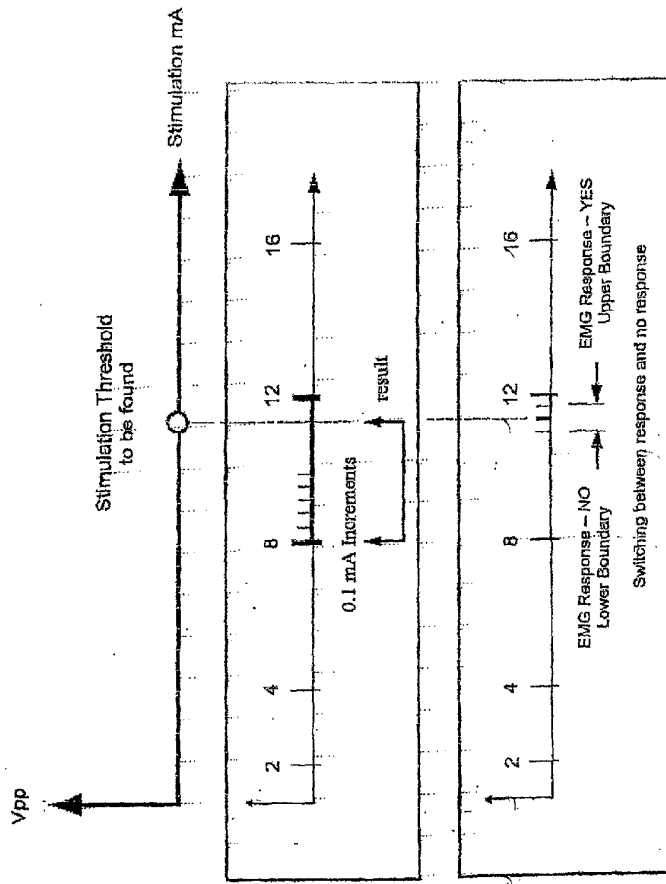

FIG. 22A

FIG. 22B

FIG. 22E

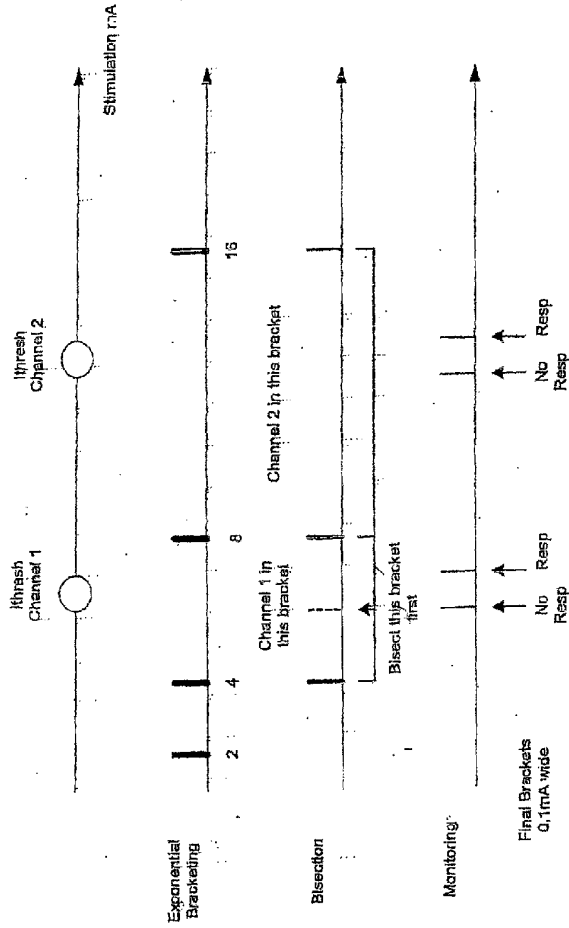

FIG. 23

Note: not to scale

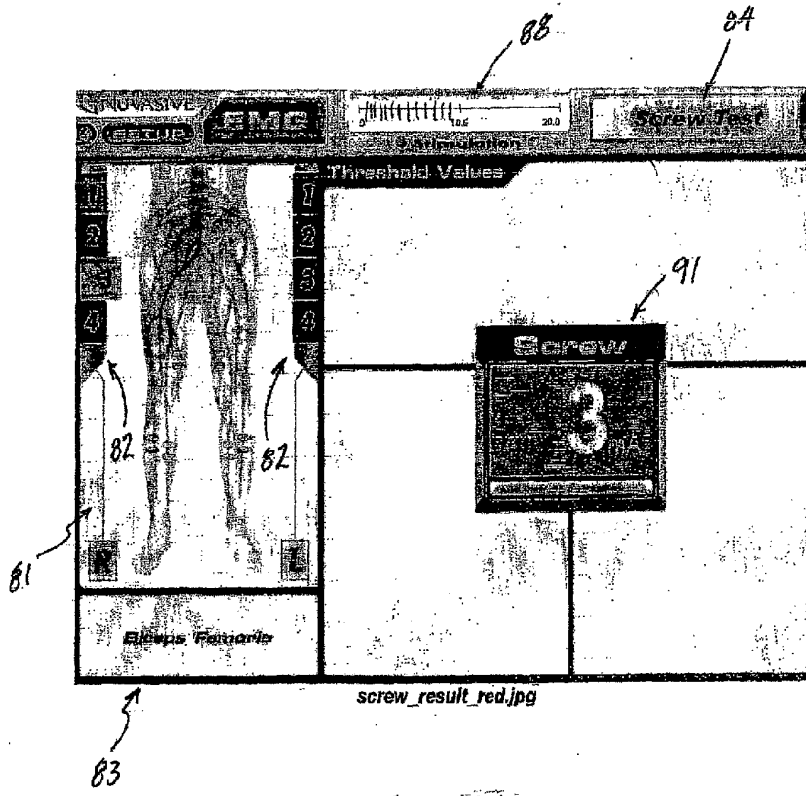

FIG. 24

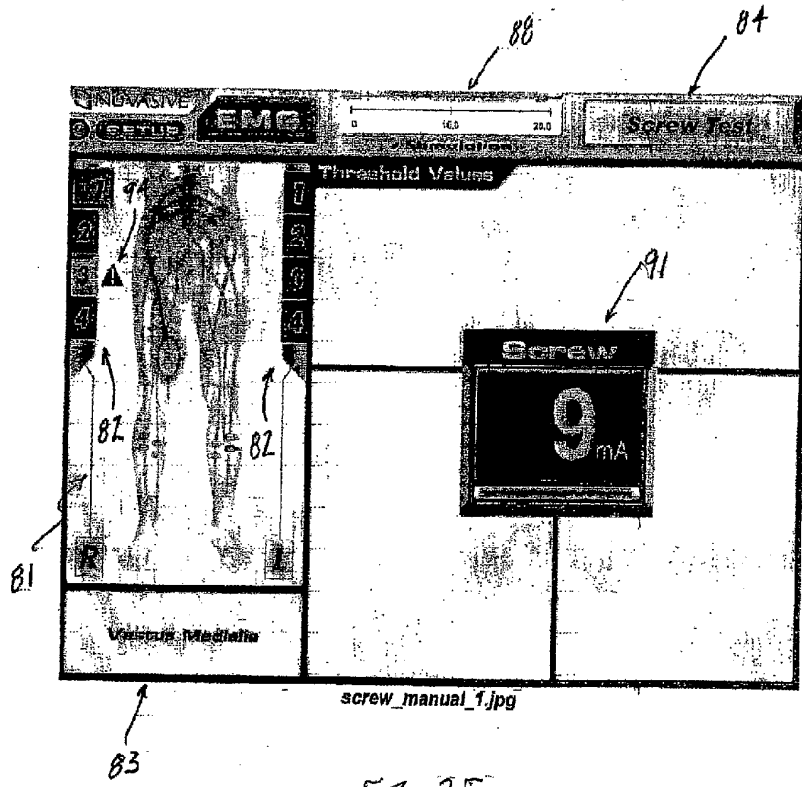

FIG. 25

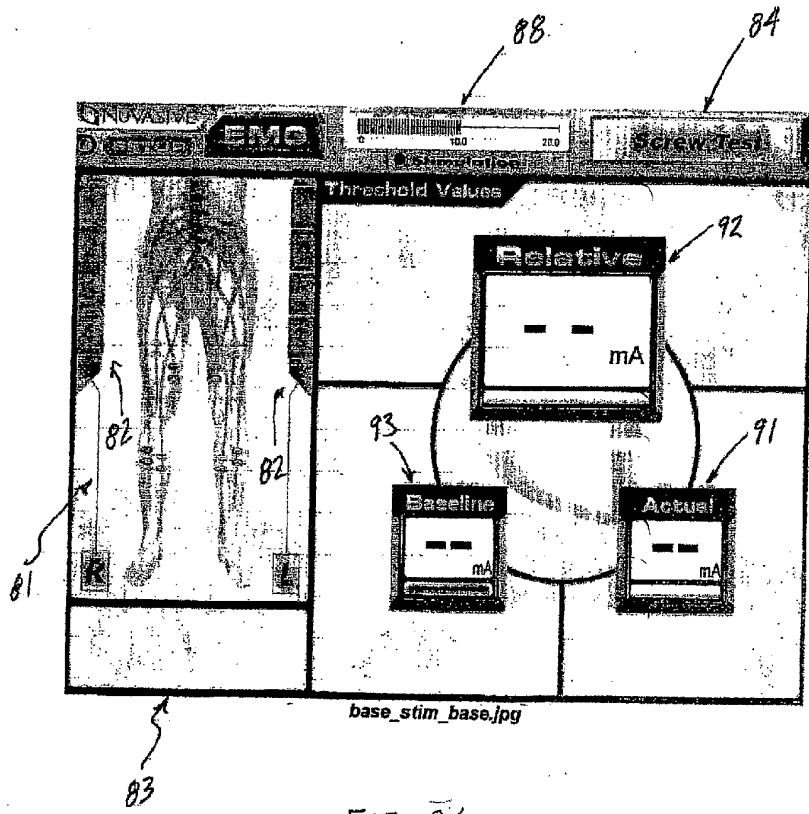
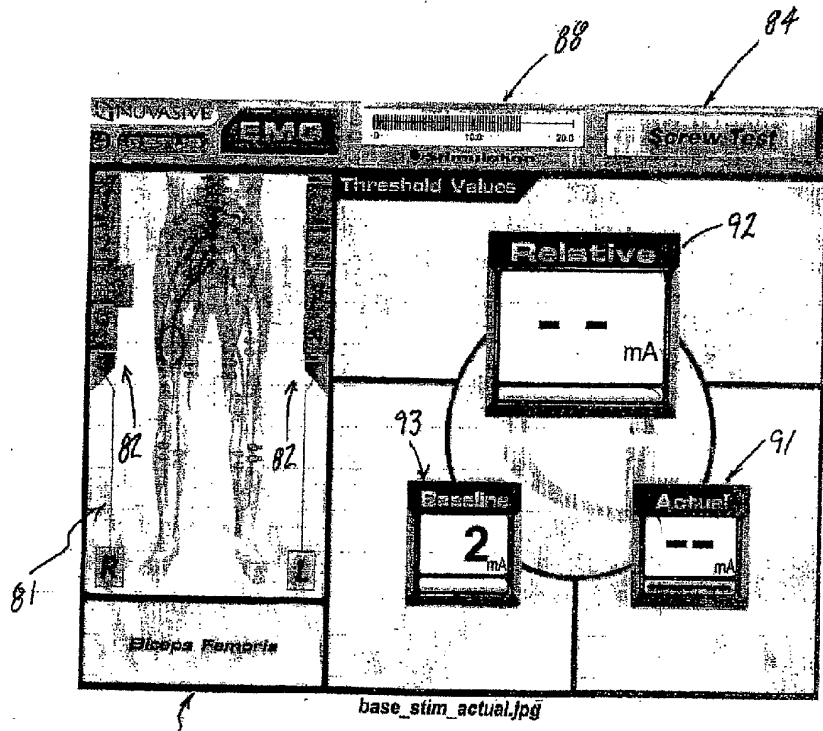

FIG. 26



83

FIG. 27

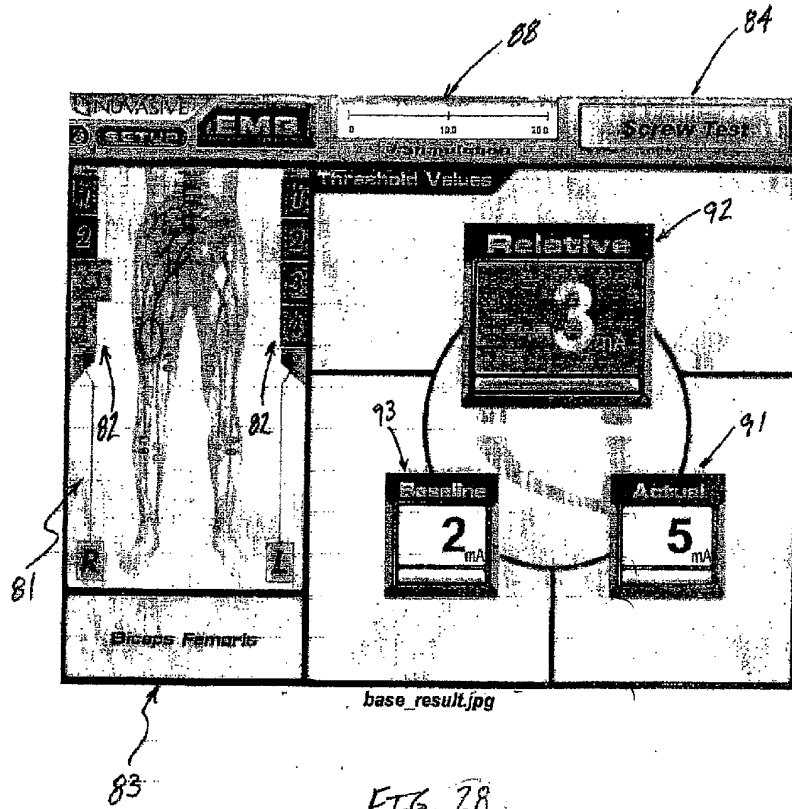

FIG. 28